



Easy-to-Use, Low-Power, Low-Supply TEMPERATURE SWITCH in MicroPackage

Check for Samples: [TMP302A](#) [TMP302B](#) [TMP302C](#) [TMP302D](#)

FEATURES

- **LOW POWER:** 15µA (max)
- **SOT563 PACKAGE:** 1,6mm x 1,6mm x 0,6mm
- **TRIP-POINT ACCURACY:** ±0.2°C (typ) from +40°C to +125°C
- **PIN-SELECTABLE TRIP POINTS**
- **OPEN-DRAIN OUTPUT**
- **SELECTABLE HYSTERESIS:** 5°C/10°C
- **LOW SUPPLY VOLTAGE RANGE:** 1.4V to 3.6V

APPLICATIONS

- CELL PHONE HANDSETS
- PORTABLE MEDIA PLAYERS
- CONSUMER ELECTRONICS
- SERVERS
- POWER-SUPPLY SYSTEMS
- DC-DC MODULES
- THERMAL MONITORING
- ELECTRONIC PROTECTION SYSTEMS

DESCRIPTION

The TMP302x is a temperature switch in a micropackage (SOT563). The TMP302x offers low power (15µA max) and ease-of-use through pin-selectable trip points and hysteresis.

These devices require no additional components for operation; they can function independent of microprocessors or microcontrollers.

The TMP302x is available in several different versions. For additional trip points, contact a TI representative.

TMP302 Available Versions⁽¹⁾

DEVICE	SELECTABLE TRIP POINTS (°C)
TMP302A	50, 55, 60, 65
TMP302B	70, 75, 80, 85
TMP302C	90, 95, 100, 105
TMP302D	110, 115, 120, 125

(1) For other available trip points, please contact a TI representative.

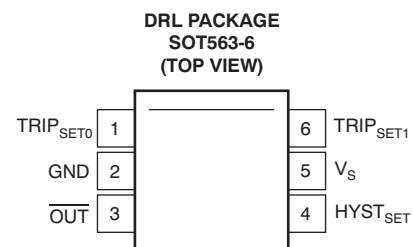
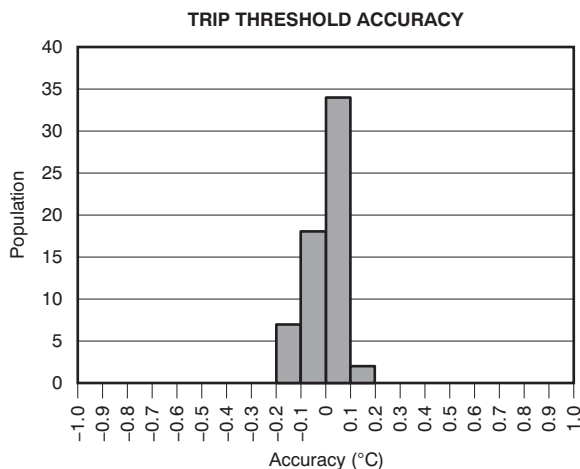

Please be aware that an important notice concerning availability, standard warranty, and use in critical applications of Texas Instruments semiconductor products and disclaimers thereto appears at the end of this data sheet.

All trademarks are the property of their respective owners.



This integrated circuit can be damaged by ESD. Texas Instruments recommends that all integrated circuits be handled with appropriate precautions. Failure to observe proper handling and installation procedures can cause damage.

ESD damage can range from subtle performance degradation to complete device failure. Precision integrated circuits may be more susceptible to damage because very small parametric changes could cause the device not to meet its published specifications.

PACKAGE INFORMATION⁽¹⁾

PRODUCT	TRIP POINTS (°C)	PACKAGE-LEAD	PACKAGE DESIGNATOR	PACKAGE MARKING
TMP302A	50, 55, 60, 65	SOT563	DRL	OCP
TMP302B	70, 75, 80, 85	SOT563	DRL	OCT
TMP302C	90, 95, 100, 105	SOT563	DRL	OCR
TMP302D	110, 115, 120, 125	SOT563	DRL	OCS

(1) For the most current package and ordering information see the Package Option Addendum at the end of this document, or see the TI web site at www.ti.com.

ABSOLUTE MAXIMUM RATINGS⁽¹⁾

		TMP302A, TMP302B, TMP302C, TMP302D	UNIT
Supply Voltage		+3.6	V
Input Pins, Voltage	TRIP _{SET0} , TRIP _{SET1} , HYST _{SET}	-0.5 to V _S + 0.5	V
Output Pin, Voltage	$\overline{\text{OUT}}$	-0.5 to +3.6	V
Output Pin, Current	$\overline{\text{OUT}}$	10	mA
Operating Temperature		-55 to +130	°C
Storage Temperature Range		-60 to +150	°C
Junction Temperature Range		+150	°C
ESD Rating:	Human Body Model (HBM)	2000	V
	Charged-Device Model (CDM)	1000	V
	Machine Model (MM)	200	V

(1) Stresses above these ratings may cause permanent damage. Exposure to absolute maximum conditions for extended periods may degrade device reliability. These are stress ratings only, and functional operation of the device at these or any other conditions beyond those specified is not supported.

ELECTRICAL CHARACTERISTICS

 At $T_A = -40^\circ\text{C}$ to $+125^\circ\text{C}$, and $V_S = +1.4\text{V}$ to $+3.6\text{V}$, unless otherwise noted.

PARAMETER	TEST CONDITIONS	TMP302 (1)			UNIT
		MIN	TYP	MAX	
TEMPERATURE MEASUREMENT					
Trip Point Accuracy vs. Supply	$T_A = +40^\circ\text{C}$ to $+125^\circ\text{C}$		± 0.2	± 2	$^\circ\text{C}$
Trip Point Hysteresis	$\text{HYST}_{\text{SET}} = \text{GND}$ $\text{HYST}_{\text{SET}} = V_S$		± 0.2 5 10	± 0.5	$^\circ\text{C/V}$ $^\circ\text{C}$ $^\circ\text{C}$
TEMPERATURE TRIP POINT SET					
Temperature Trip Point Set	$\text{TRIP}_{\text{SET1}} = \text{GND}, \text{TRIP}_{\text{SET0}} = \text{GND}$ $\text{TRIP}_{\text{SET1}} = \text{GND}, \text{TRIP}_{\text{SET0}} = V_S$ $\text{TRIP}_{\text{SET1}} = V_S, \text{TRIP}_{\text{SET0}} = \text{GND}$ $\text{TRIP}_{\text{SET1}} = V_S, \text{TRIP}_{\text{SET0}} = V_S$		Default Default + 5 Default + 10 Default + 15		$^\circ\text{C}$ $^\circ\text{C}$ $^\circ\text{C}$ $^\circ\text{C}$
HYSTERESIS SET INPUT					
Input Logic Levels:					
V_{IH}		$0.7 \times (V_S)$		V_S	V
V_{IL}		-0.5		$0.3 \times (V_S)$	V
Input Current:					
I_{IN}	$0 < V_{\text{IN}} < 3.6\text{V}$			1	μA
DIGITAL OUTPUT					
Output Logic Level:					
V_{OL}	$V_S > 2\text{V}, I_{\text{OL}} = 3\text{mA}$ $V_S < 2\text{V}, I_{\text{OL}} = 3\text{mA}$	0 0		0.4 $0.2 \times (V_S)$	V V
POWER SUPPLY					
Operating Supply Range		1.4		3.6	V
Quiescent Current	I_Q $V_S = 3.3\text{V}, T_A = +50^\circ\text{C}$		8 7	15	μA μA
TEMPERATURE RANGE					
Specified Range		-40		+125	$^\circ\text{C}$
Operating Range		-55		+130	$^\circ\text{C}$
Thermal Resistance	θ_{JA}				
SOT563	JEDEC Low-K Board		+260		$^\circ\text{C/W}$

 (1) 100% of all units are production tested at $T_A = +25^\circ\text{C}$. Over temperature specifications are specified by design.

TYPICAL CHARACTERISTICS

At $T_A = +25^\circ\text{C}$ and $V_S = 3.3\text{V}$, unless otherwise noted.

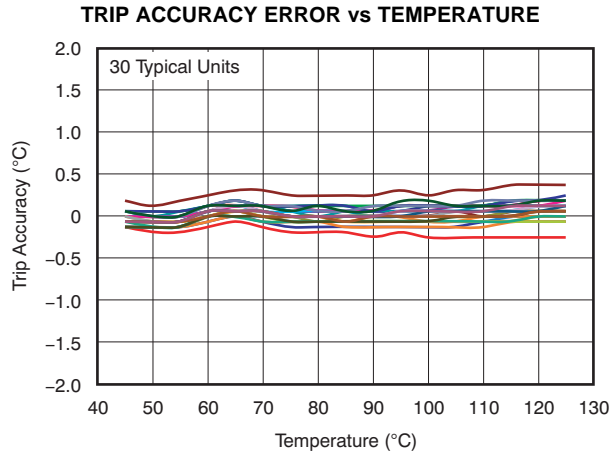

Figure 1.

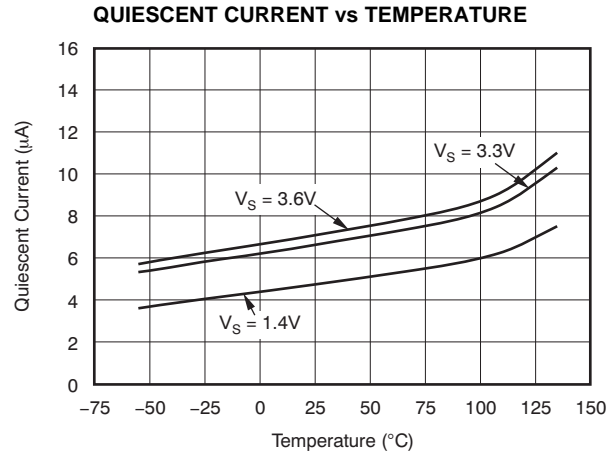

Figure 2.

TEMPERATURE STEP RESPONSE IN PERFLUORINATED FLUID AT +100°C vs TIME

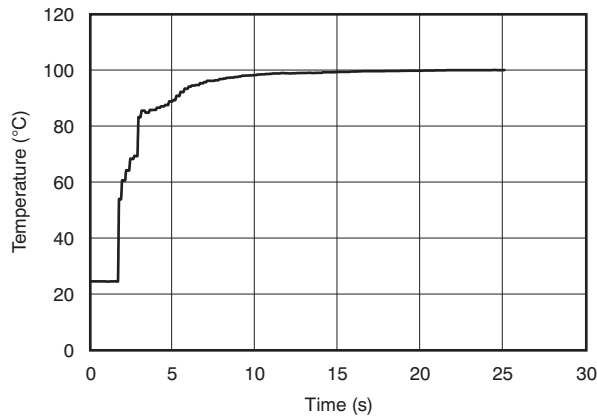

Figure 3.

THERMAL STEP RESPONSE IN AIR AT +100°C vs TIME

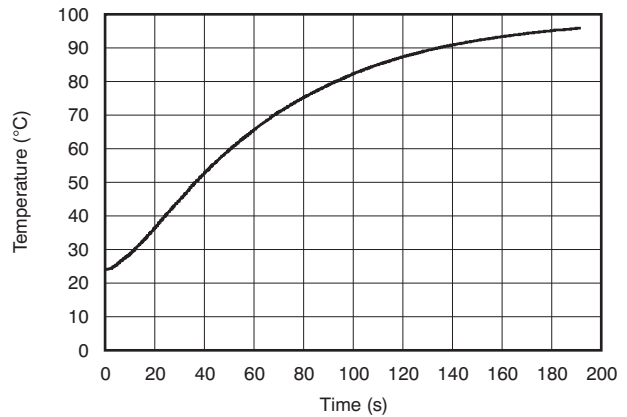

Figure 4.

TRIP THRESHOLD ACCURACY

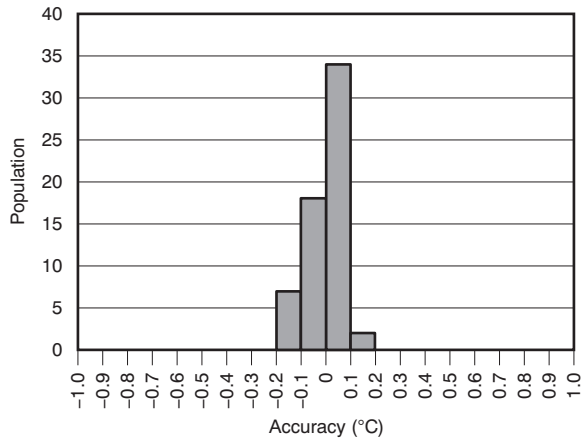

Figure 5.

OUTPUT LOGIC LEVEL LOW V_{OL} vs TEMPERATURE

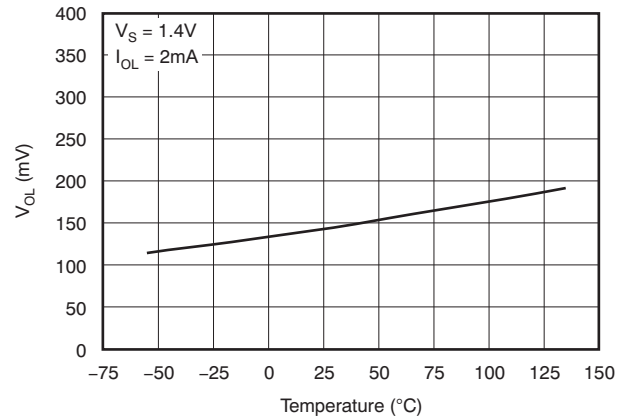

Figure 6.

TYPICAL CHARACTERISTICS (continued)

At $T_A = +25^\circ\text{C}$ and $V_S = 3.3\text{V}$, unless otherwise noted.

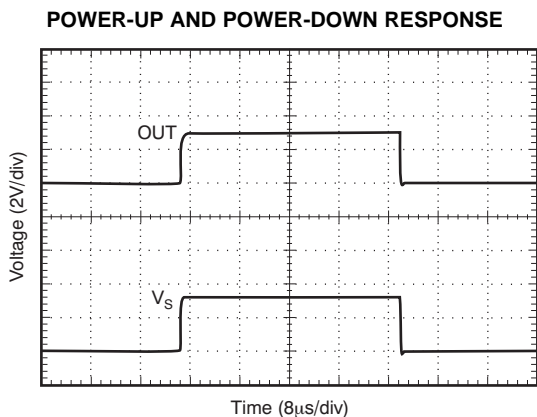

Figure 7.

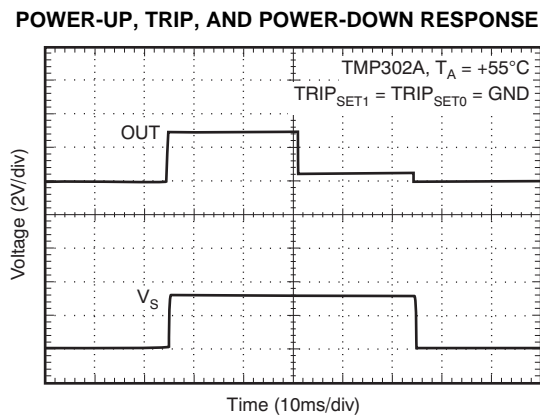

Figure 8.

APPLICATION INFORMATION

The TMP302 temperature switch is optimal for ultralow-power battery applications that require accurate trip thresholds. The trip thresholds are programmable to four different settings using the TRIP_{SET1} and TRIP_{SET0} pins. Table 1 shows the pin settings versus trip points.

Table 1. Trip Point vs TRIP_{SET1} and TRIP_{SET0}

TRIP _{SET1}	TRIP _{SET0}	TMP302A	TMP302B	TMP302C	TMP302D
GND	GND	+50°C	+70°C	+90°C	+110°C
GND	V _S	+55°C	+75°C	+95°C	+115°C
V _S	GND	+60°C	+80°C	+100°C	+120°C
V _S	V _S	+65°C	+85°C	+105°C	+125°C

The typical thermal response time for the TMP302 is about 250ms. This period is the minimum time frame that it takes for the open-drain output ($\overline{\text{OUT}}$) to change its state from low to high (or vice-versa) while the device is active. A maximum low output voltage is defined as a voltage level equivalent to $0.2 \times V_S$; likewise, a minimum high output voltage is defined as $0.8 \times V_S$. It is important to note that an exception to the nominal 250ms response time occurs on power up—in this case, it is possible to achieve a thermal response in as little as 35ms.

CONFIGURING THE TMP302

The TMP302 is simple to configure. The only external components that it requires are a bypass capacitor and pull-up resistor. Power-supply bypassing is strongly recommended; use a 0.1 μ F capacitor placed as close as possible to the supply pin. To minimize the internal power dissipation of the TMP302, use a pull-up resistor value greater than 10k Ω from $\overline{\text{OUT}}$ to V_S. Refer to Table 1 for trip point temperature configuration. The TRIP_{SET} pins can be toggled dynamically; however, the voltage of these pins must not exceed V_S. To ensure a proper logic high, the voltage must not drop below $0.7V \times V_S$.

HYST_{SET}

If the temperature trip threshold is crossed, the open-drain output ($\overline{\text{OUT}}$) goes low and does not return to its original high state (that is, V_S) until the temperature returns to a value within a hysteresis window set by the HYST_{SET} pin. The HYST_{SET} pin allows the user to choose between a +5°C and a +10°C hysteresis window. Table 2 shows the hysteresis window that corresponds to the HYST_{SET} setting.

Table 2. HYST_{SET} Window

HYST _{SET}	THRESHOLD HYSTERESIS
GND	+5°C
V _S	+10°C

For the specific case of the TMP302A, if the HYST_{SET} pin is set to +10°C (that is, connected to V_S) and the device is configured with a +60°C trip point (TRIP_{SET1} = V_S, TRIP_{SET0} = GND), once this threshold is exceeded the output does not return to its original high state until it reaches +50°C. This case is more clearly illustrated in Figure 9.

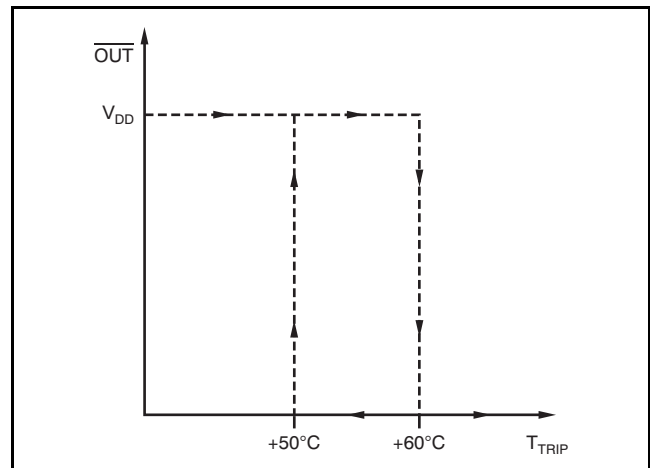

Figure 9. TMP302A; HYST_{SET} = V_S; TRIP_{SET1} = V_S, TRIP_{SET0} = GND

PACKAGING INFORMATION

Orderable Device	Status ⁽¹⁾	Package Type	Package Drawing	Pins	Package Qty	Eco Plan ⁽²⁾	Lead/Ball Finish	MSL Peak Temp ⁽³⁾
TMP302ADRLR	ACTIVE	SOT	DRL	6	4000	Green (RoHS & no Sb/Br)	CU NIPDAU	Level-1-260C-UNLIM
TMP302ADRLT	ACTIVE	SOT	DRL	6	250	Green (RoHS & no Sb/Br)	CU NIPDAU	Level-1-260C-UNLIM
TMP302BDRLR	ACTIVE	SOT	DRL	6	4000	Green (RoHS & no Sb/Br)	CU NIPDAU	Level-1-260C-UNLIM
TMP302BDRLT	ACTIVE	SOT	DRL	6	250	Green (RoHS & no Sb/Br)	CU NIPDAU	Level-1-260C-UNLIM
TMP302CDRLR	ACTIVE	SOT	DRL	6	4000	Green (RoHS & no Sb/Br)	CU NIPDAU	Level-1-260C-UNLIM
TMP302CDRLT	ACTIVE	SOT	DRL	6	250	Green (RoHS & no Sb/Br)	CU NIPDAU	Level-1-260C-UNLIM
TMP302DDRLR	ACTIVE	SOT	DRL	6	4000	Green (RoHS & no Sb/Br)	CU NIPDAU	Level-1-260C-UNLIM
TMP302DDRLT	ACTIVE	SOT	DRL	6	250	Green (RoHS & no Sb/Br)	CU NIPDAU	Level-1-260C-UNLIM

⁽¹⁾ The marketing status values are defined as follows:

ACTIVE: Product device recommended for new designs.

LIFEBUY: TI has announced that the device will be discontinued, and a lifetime-buy period is in effect.

NRND: Not recommended for new designs. Device is in production to support existing customers, but TI does not recommend using this part in a new design.

PREVIEW: Device has been announced but is not in production. Samples may or may not be available.

OBSOLETE: TI has discontinued the production of the device.

⁽²⁾ Eco Plan - The planned eco-friendly classification: Pb-Free (RoHS), Pb-Free (RoHS Exempt), or Green (RoHS & no Sb/Br) - please check <http://www.ti.com/productcontent> for the latest availability information and additional product content details.

TBD: The Pb-Free/Green conversion plan has not been defined.

Pb-Free (RoHS): TI's terms "Lead-Free" or "Pb-Free" mean semiconductor products that are compatible with the current RoHS requirements for all 6 substances, including the requirement that lead not exceed 0.1% by weight in homogeneous materials. Where designed to be soldered at high temperatures, TI Pb-Free products are suitable for use in specified lead-free processes.

Pb-Free (RoHS Exempt): This component has a RoHS exemption for either 1) lead-based flip-chip solder bumps used between the die and package, or 2) lead-based die adhesive used between the die and leadframe. The component is otherwise considered Pb-Free (RoHS compatible) as defined above.

Green (RoHS & no Sb/Br): TI defines "Green" to mean Pb-Free (RoHS compatible), and free of Bromine (Br) and Antimony (Sb) based flame retardants (Br or Sb do not exceed 0.1% by weight in homogeneous material)

⁽³⁾ MSL, Peak Temp. -- The Moisture Sensitivity Level rating according to the JEDEC industry standard classifications, and peak solder temperature.

Important Information and Disclaimer: The information provided on this page represents TI's knowledge and belief as of the date that it is provided. TI bases its knowledge and belief on information provided by third parties, and makes no representation or warranty as to the accuracy of such information. Efforts are underway to better integrate information from third parties. TI has taken and continues to take reasonable steps to provide representative and accurate information but may not have conducted destructive testing or chemical analysis on incoming materials and chemicals. TI and TI suppliers consider certain information to be proprietary, and thus CAS numbers and other limited information may not be available for release.

In no event shall TI's liability arising out of such information exceed the total purchase price of the TI part(s) at issue in this document sold by TI to Customer on an annual basis.

TAPE AND REEL INFORMATION

QUADRANT ASSIGNMENTS FOR PIN 1 ORIENTATION IN TAPE

*All dimensions are nominal

Device	Package Type	Package Drawing	Pins	SPQ	Reel Diameter (mm)	Reel Width W1 (mm)	A0 (mm)	B0 (mm)	K0 (mm)	P1 (mm)	W (mm)	Pin1 Quadrant
TMP302ADRLR	SOT	DRL	6	4000	180.0	8.4	1.78	1.78	0.69	4.0	8.0	Q3
TMP302ADRLT	SOT	DRL	6	250	180.0	8.4	1.78	1.78	0.69	4.0	8.0	Q3
TMP302BDRLR	SOT	DRL	6	4000	180.0	8.4	1.78	1.78	0.69	4.0	8.0	Q3
TMP302BDRLT	SOT	DRL	6	250	180.0	8.4	1.78	1.78	0.69	4.0	8.0	Q3
TMP302CDRLR	SOT	DRL	6	4000	180.0	8.4	1.78	1.78	0.69	4.0	8.0	Q3
TMP302DDRLR	SOT	DRL	6	4000	180.0	8.4	1.78	1.78	0.69	4.0	8.0	Q3
TMP302DDRLT	SOT	DRL	6	250	180.0	8.4	1.78	1.78	0.69	4.0	8.0	Q3

TAPE AND REEL BOX DIMENSIONS

*All dimensions are nominal

Device	Package Type	Package Drawing	Pins	SPQ	Length (mm)	Width (mm)	Height (mm)
TMP302ADRLR	SOT	DRL	6	4000	202.0	201.0	28.0
TMP302ADRLT	SOT	DRL	6	250	202.0	201.0	28.0
TMP302BDRLR	SOT	DRL	6	4000	202.0	201.0	28.0
TMP302BDRLT	SOT	DRL	6	250	202.0	201.0	28.0
TMP302CDRLR	SOT	DRL	6	4000	202.0	201.0	28.0
TMP302DDRLR	SOT	DRL	6	4000	202.0	201.0	28.0
TMP302DDRLT	SOT	DRL	6	250	202.0	201.0	28.0

DRL (R-PDSO-N6)

PLASTIC SMALL OUTLINE

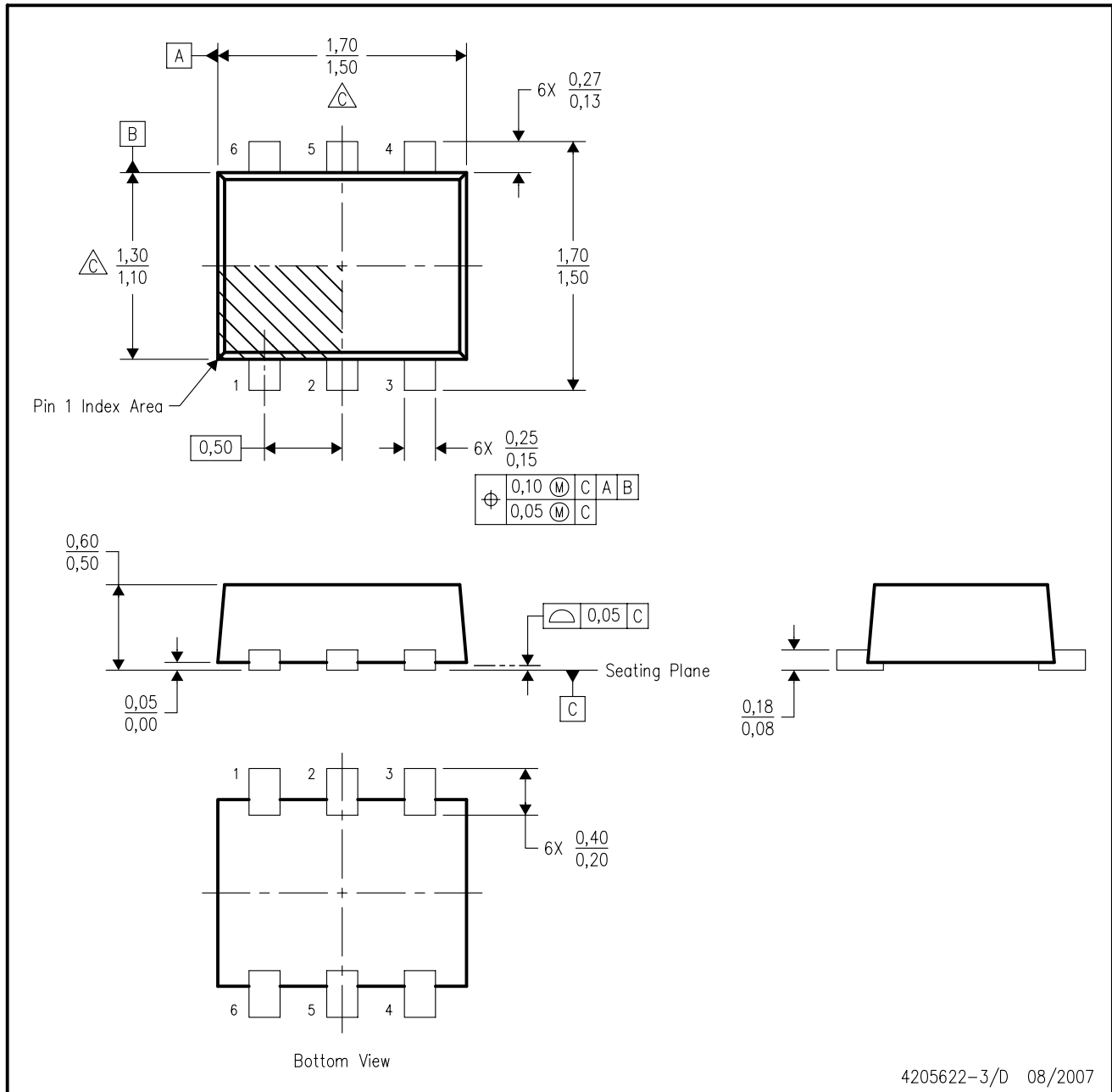

4205622-3/D 08/2007

- NOTES:
- A. All linear dimensions are in millimeters. Dimensioning and tolerancing per ASME Y14.5M-1994.
 - B. This drawing is subject to change without notice.
 - C. Body dimensions do not include mold flash, interlead flash, protrusions, or gate burrs. Mold flash, interlead flash, protrusions, or gate burrs shall not exceed 0,15 per end or side.
 - D. JEDEC package registration is pending.

IMPORTANT NOTICE

Texas Instruments Incorporated and its subsidiaries (TI) reserve the right to make corrections, modifications, enhancements, improvements, and other changes to its products and services at any time and to discontinue any product or service without notice. Customers should obtain the latest relevant information before placing orders and should verify that such information is current and complete. All products are sold subject to TI's terms and conditions of sale supplied at the time of order acknowledgment.

TI warrants performance of its hardware products to the specifications applicable at the time of sale in accordance with TI's standard warranty. Testing and other quality control techniques are used to the extent TI deems necessary to support this warranty. Except where mandated by government requirements, testing of all parameters of each product is not necessarily performed.

TI assumes no liability for applications assistance or customer product design. Customers are responsible for their products and applications using TI components. To minimize the risks associated with customer products and applications, customers should provide adequate design and operating safeguards.

TI does not warrant or represent that any license, either express or implied, is granted under any TI patent right, copyright, mask work right, or other TI intellectual property right relating to any combination, machine, or process in which TI products or services are used. Information published by TI regarding third-party products or services does not constitute a license from TI to use such products or services or a warranty or endorsement thereof. Use of such information may require a license from a third party under the patents or other intellectual property of the third party, or a license from TI under the patents or other intellectual property of TI.

Reproduction of TI information in TI data books or data sheets is permissible only if reproduction is without alteration and is accompanied by all associated warranties, conditions, limitations, and notices. Reproduction of this information with alteration is an unfair and deceptive business practice. TI is not responsible or liable for such altered documentation. Information of third parties may be subject to additional restrictions.

Resale of TI products or services with statements different from or beyond the parameters stated by TI for that product or service voids all express and any implied warranties for the associated TI product or service and is an unfair and deceptive business practice. TI is not responsible or liable for any such statements.

TI products are not authorized for use in safety-critical applications (such as life support) where a failure of the TI product would reasonably be expected to cause severe personal injury or death, unless officers of the parties have executed an agreement specifically governing such use. Buyers represent that they have all necessary expertise in the safety and regulatory ramifications of their applications, and acknowledge and agree that they are solely responsible for all legal, regulatory and safety-related requirements concerning their products and any use of TI products in such safety-critical applications, notwithstanding any applications-related information or support that may be provided by TI. Further, Buyers must fully indemnify TI and its representatives against any damages arising out of the use of TI products in such safety-critical applications.

TI products are neither designed nor intended for use in military/aerospace applications or environments unless the TI products are specifically designated by TI as military-grade or "enhanced plastic." Only products designated by TI as military-grade meet military specifications. Buyers acknowledge and agree that any such use of TI products which TI has not designated as military-grade is solely at the Buyer's risk, and that they are solely responsible for compliance with all legal and regulatory requirements in connection with such use.

TI products are neither designed nor intended for use in automotive applications or environments unless the specific TI products are designated by TI as compliant with ISO/TS 16949 requirements. Buyers acknowledge and agree that, if they use any non-designated products in automotive applications, TI will not be responsible for any failure to meet such requirements.

Following are URLs where you can obtain information on other Texas Instruments products and application solutions:

Products

Amplifiers	amplifier.ti.com
Data Converters	dataconverter.ti.com
DLP® Products	www.dlp.com
DSP	dsp.ti.com
Clocks and Timers	www.ti.com/clocks
Interface	interface.ti.com
Logic	logic.ti.com
Power Mgmt	power.ti.com
Microcontrollers	microcontroller.ti.com
RFID	www.ti-rfid.com
RF/IF and ZigBee® Solutions	www.ti.com/lprf

Applications

Audio	www.ti.com/audio
Automotive	www.ti.com/automotive
Broadband	www.ti.com/broadband
Digital Control	www.ti.com/digitalcontrol
Medical	www.ti.com/medical
Military	www.ti.com/military
Optical Networking	www.ti.com/opticalnetwork
Security	www.ti.com/security
Telephony	www.ti.com/telephony
Video & Imaging	www.ti.com/video
Wireless	www.ti.com/wireless

Mailing Address: Texas Instruments, Post Office Box 655303, Dallas, Texas 75265
Copyright © 2009, Texas Instruments Incorporated