

## 3-Pin Voltage Supervisors with Active-High, Push-Pull Reset

Check for Samples: [TLV810M](#), [TLV810R](#), [TLV810S](#), [TLV810Z](#)

### FEATURES

- 3-Pin SOT23 Package
- Supply Current: 9  $\mu$ A (Typical)
- Precision Supply Voltage Monitor: 2.5 V, 3 V, 3.3 V, 5 V
- Power-On Reset Generator with Fixed Delay Time of 200 ms
- Pin-for-Pin Compatible with MAX810
- Temperature Range:  $-40^{\circ}\text{C}$  to  $+125^{\circ}\text{C}$
- Push-Pull, RESET Output

### APPLICATIONS

- DSPs, Microcontrollers, and Microprocessors
- Wireless Communication Systems
- Portable/Battery-Powered Equipment
- Programmable Controls
- Intelligent Instruments
- Industrial Equipment
- Notebook and Desktop Computers
- Automotive Systems

#### DEVICE FAMILY COMPARISON

DEVICE	FUNCTION
<a href="#">TLV803</a>	Open-Drain, $\overline{\text{RESET}}$ Output
<a href="#">TLV809</a>	Push-Pull, $\overline{\text{RESET}}$ Output
<a href="#">TLV810</a>	Push-Pull, RESET Output

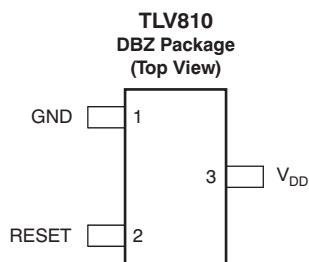

### DESCRIPTION

The [TLV810](#) family of supervisory circuits provides circuit initialization and timing supervision, primarily for DSPs and processor-based systems.

During power-on, RESET is asserted when the supply voltage ( $V_{\text{DD}}$ ) becomes higher than 1.1 V. Thereafter, the supervisory circuit monitors  $V_{\text{DD}}$  and keeps RESET active as long as  $V_{\text{DD}}$  remains below the threshold voltage  $V_{\text{IT}}$ . An internal timer delays the return of the output to the inactive state (low) to ensure proper system reset. The delay time ( $t_{\text{d(typ)}}$  = 200 ms) starts after  $V_{\text{DD}}$  has risen above the threshold voltage,  $V_{\text{IT}}$ . When the supply voltage drops below the  $V_{\text{IT}}$  threshold voltage, the output becomes active (high) again. No external components are required. All the devices in this family have a fixed sense-threshold voltage ( $V_{\text{IT}}$ ) set by an internal voltage divider.

The product spectrum is designed for supply voltages of 2.5 V, 3 V, 3.3 V, and 5 V. The circuits are available in a 3-pin SOT-23 package. The TLV810 devices are characterized for operation over a temperature range of  $-40^{\circ}\text{C}$  to  $+125^{\circ}\text{C}$ .

#### TYPICAL APPLICATION

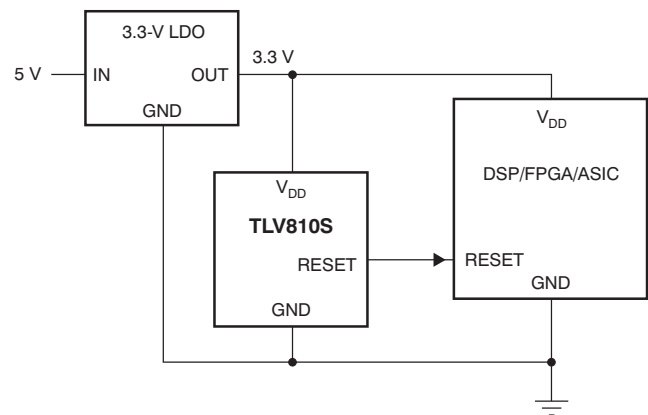

Please be aware that an important notice concerning availability, standard warranty, and use in critical applications of Texas Instruments semiconductor products and disclaimers thereto appears at the end of this data sheet.

All trademarks are the property of their respective owners.



This integrated circuit can be damaged by ESD. Texas Instruments recommends that all integrated circuits be handled with appropriate precautions. Failure to observe proper handling and installation procedures can cause damage.

ESD damage can range from subtle performance degradation to complete device failure. Precision integrated circuits may be more susceptible to damage because very small parametric changes could cause the device not to meet its published specifications.

### PACKAGE/ORDERING INFORMATION<sup>(1)</sup>

PRODUCT	THRESHOLD VOLTAGE	PACKAGE-LEAD	PACKAGE DESIGNATOR	SPECIFIED OPERATING TEMPERATURE	PACKAGE MARKING	ORDERING INFORMATION	TRANSPORT MEDIA, QUANTITY
TLV810Z	2.25 V	SOT23-3	DBZ	-40°C to +125°C	VOVQ	TLV810ZDBZR	Tape and Reel, 3000
						TLV810ZDBZT	Tape and Reel, 250
TLV810R	2.64 V	SOT23-3	DBZ	-40°C to +125°C	VOWQ	TLV810RDBZR	Tape and Reel, 3000
						TLV810RDBZT	Tape and Reel, 250
TLV810S	2.93 V	SOT23-3	DBZ	-40°C to +125°C	VOXQ	TLV810SDBZR	Tape and Reel, 3000
						TLV810SDBZT	Tape and Reel, 250
TLV810M	4.38 V	SOT23-3	DBZ	-40°C to +125°C	VOYQ	TLV810MDBZR	Tape and Reel, 3000
						TLV810MDBZT	Tape and Reel, 250

(1) For the most current package and ordering information, see the Package Option Addendum at the end of this data sheet, or visit the [device product folders](http://www.ti.com) at [www.ti.com](http://www.ti.com).

### ABSOLUTE MAXIMUM RATINGS<sup>(1)</sup>

Over operating free-air temperature range (unless otherwise noted).

		VALUE		UNIT
		MIN	MAX	
Voltage	$V_{DD}$ <sup>(2)</sup>	0	7	V
	All other pins <sup>(2)</sup>	-0.3	7	V
Current	Maximum low output current, $I_{OL}$		5	mA
	Maximum high output current, $I_{OH}$		-5	mA
	Input clamp current, $I_{IK}$ ( $V_I < 0$ or $V_I > V_{DD}$ )		±20	mA
	Output clamp current, $I_{OK}$ ( $V_O < 0$ or $V_O > V_{DD}$ )		±20	mA
Temperature	Operating free-air temperature range, $T_A$	-40	+125	°C
	Storage temperature range, $T_{stg}$	-65	+150	°C
	Soldering temperature		+260	°C

(1) Stresses beyond those listed under *Absolute Maximum Ratings* may cause permanent damage to the device. These are stress ratings only, and functional operation of the device at these or any other conditions beyond those indicated under *Recommended Operating Conditions* is not implied. Exposure to absolute-maximum-rated conditions for extended periods may affect device reliability.

(2) All voltage values are with respect to GND. For reliable operation the device should not be operated at 7 V for more than  $t = 1000h$  continuously.

### THERMAL INFORMATION

THERMAL METRIC <sup>(1)</sup>		TLV810	UNITS
		DBZ	
		3 PINS	
$\theta_{JA}$	Junction-to-ambient thermal resistance	286.9	°C/W
$\theta_{JCTop}$	Junction-to-case (top) thermal resistance	105.6	
$\theta_{JB}$	Junction-to-board thermal resistance	124.4	
$\psi_{JT}$	Junction-to-top characterization parameter	25.8	
$\psi_{JB}$	Junction-to-board characterization parameter	107.9	
$\theta_{JCbott}$	Junction-to-case (bottom) thermal resistance	—	

(1) For more information about traditional and new thermal metrics, see the *IC Package Thermal Metrics* application report, [SPRA953](http://www.ti.com).

## RECOMMENDED OPERATING CONDITIONS

At specified temperature range (unless otherwise noted).

		MIN	MAX	UNIT
$V_{DD}$	Supply voltage	1.1	6	V
$T_A$	Operating free-air temperature range	-40	+125	°C

## ELECTRICAL CHARACTERISTICS

Over recommended operating free-air temperature range (unless otherwise noted).

PARAMETER		TEST CONDITIONS	MIN	TYP	MAX	UNIT
$V_{OH}$	High-level output voltage	$V_{DD} = 2.0\text{ V to }6\text{ V}, I_{OH} = -500\text{ }\mu\text{A}$	$V_{DD} - 0.2$			V
		$V_{DD} = 3.3\text{ V}, I_{OH} = -2\text{ mA}$	$V_{DD} - 0.4$			
		$V_{DD} = 6\text{ V}, I_{OH} = -4\text{ mA}, T_A = -40^\circ\text{C to }+85^\circ\text{C}$	$V_{DD} - 0.4$			
		$V_{DD} = 6\text{ V}, I_{OH} = -4\text{ mA}, T_A = +85^\circ\text{C to }+125^\circ\text{C}$	$V_{DD} - 0.5$			
$V_{OL}$	Low-level output voltage	$V_{DD} = 2.5\text{ V to }6\text{ V}, I_{OL} = 500\text{ }\mu\text{A}$	0.2			V
		$V_{DD} = 3.3\text{ V}, I_{OL} = 2\text{ mA}$	0.4			
		$V_{DD} = 6\text{ V}, I_{OL} = 4\text{ mA}$	0.4			
Power-up reset voltage <sup>(1)</sup>		$V_{OH} \geq V_{DD} - 0.2\text{ V}, I_{OH} = -50\text{ }\mu\text{A}$	1.1			V
$V_{IT-}$	Negative-going input threshold voltage <sup>(2)</sup>	TLV810Z	2.20	2.25	2.30	V
		TLV810R	2.58	2.64	2.70	
		TLV810S	2.87	2.93	2.99	
		TLV810M	4.28	4.38	4.48	
$V_{hys}$	Hysteresis	$I_{OH} = -50\text{ }\mu\text{A}, T_A = +25^\circ\text{C}$	30			mV
			35			
			40			
			60			
$I_{DD}$	Supply current	$V_{DD} = 2\text{ V}, \text{ output unconnected}$	9			$\mu\text{A}$
		$V_{DD} = 6\text{ V}, \text{ output unconnected}$	20			

(1) The lowest supply voltage at which RESET becomes valid.  $t_r, V_{DD} \leq 66.7\text{ ms/V}$ .

(2) To ensure best stability of the threshold voltage, a bypass capacitor ( 0.1- $\mu\text{F}$  ceramic) should be placed near the supply terminals.

## SWITCHING CHARACTERISTICS

At  $T_A = +25^\circ\text{C}$ , unless otherwise noted.

PARAMETER		TEST CONDITIONS	MIN	TYP	MAX	UNIT
$t_w$	Pulse width at $V_{DD}$	$V_{DD} = 1.08 V_{IT-}$ to $0.92 V_{IT-}$		1		$\mu\text{s}$
$t_d$	Delay time	$V_{DD} \geq V_{IT-} + 0.2 \text{ V}$ ; see <a href="#">Timing Diagram</a>	120	200	280	ms

## TIMING DIAGRAM

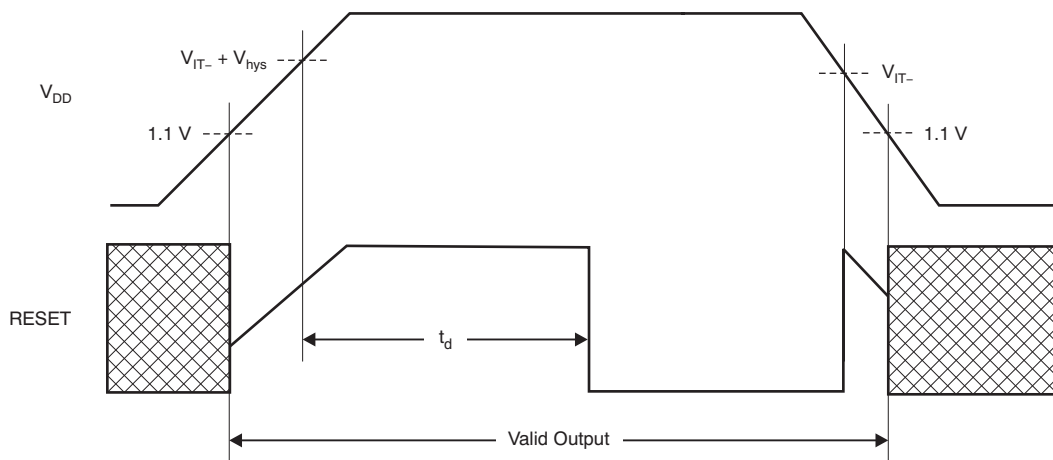

## FUNCTIONAL BLOCK DIAGRAM

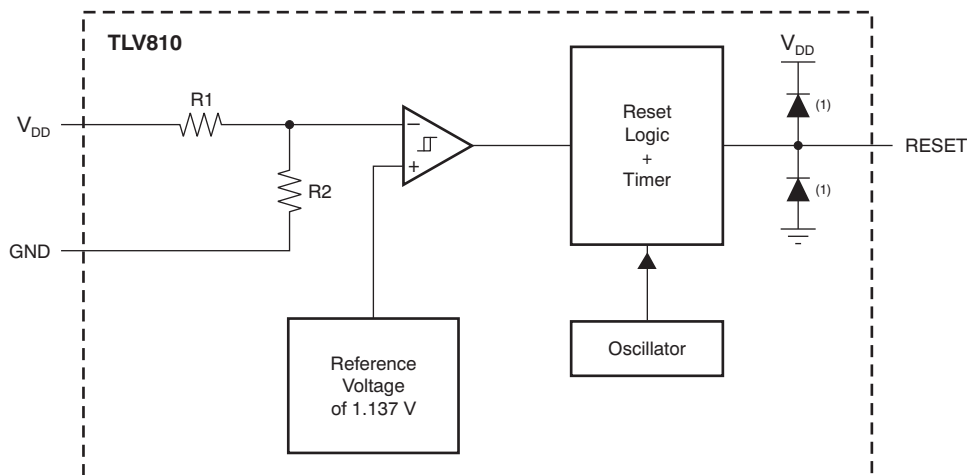

(1) Parasitic diode.

### TYPICAL CHARACTERISTICS

At  $T_A = +25^\circ\text{C}$ ,  $V_{IT-} = 4.38\text{ V}$ , and  $V_{DD} = 5.0\text{ V}$ , unless otherwise noted.

**LOW-LEVEL OUTPUT VOLTAGE vs LOW-LEVEL OUTPUT CURRENT**

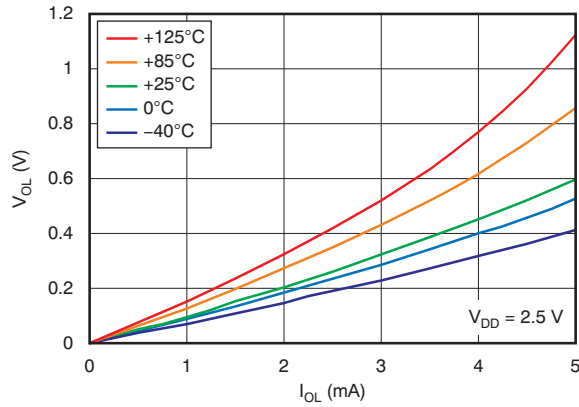

Figure 1.

**SUPPLY CURRENT vs SUPPLY VOLTAGE**

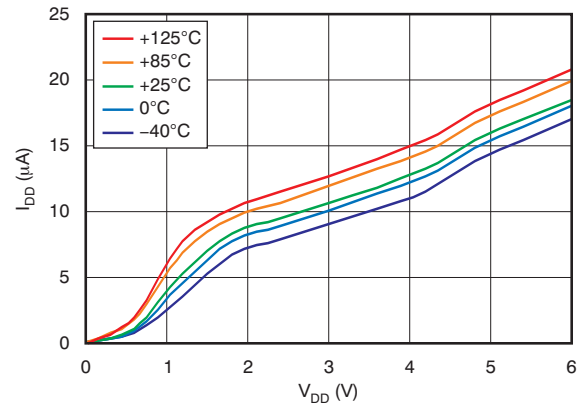

Figure 2.

**HIGH-LEVEL OUTPUT VOLTAGE vs HIGH-LEVEL OUTPUT CURRENT**

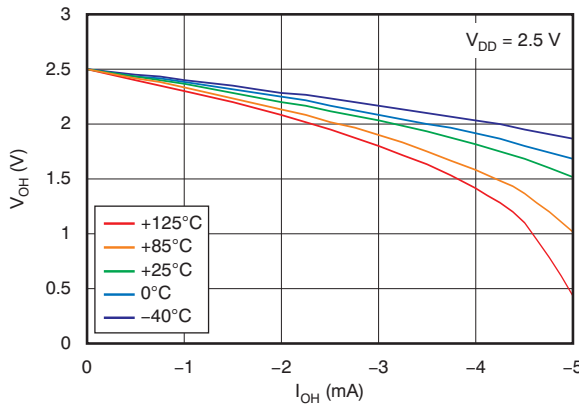

Figure 3.

**NORMALIZED INPUT THRESHOLD VOLTAGE vs FREE-AIR TEMPERATURE AT V\_DD**

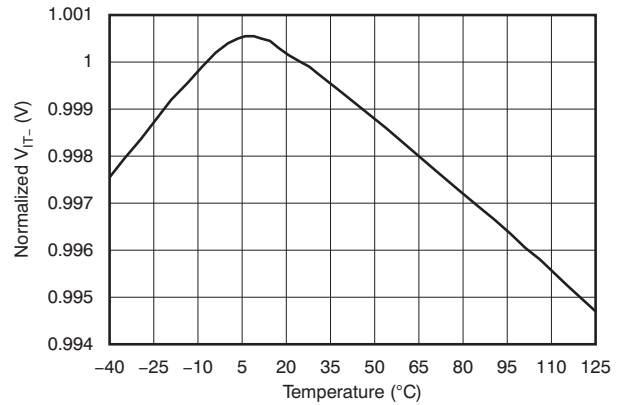

Figure 4.

**MINIMUM PULSE DURATION AT V\_DD vs V\_DD THRESHOLD OVERDRIVE VOLTAGE (TLV810M)**

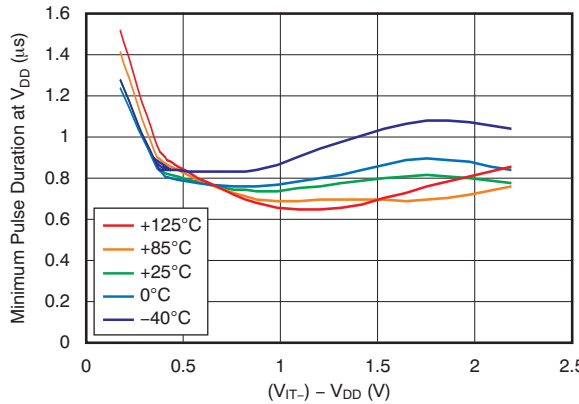

Figure 5.

**DELAY TIME vs TEMPERATURE**

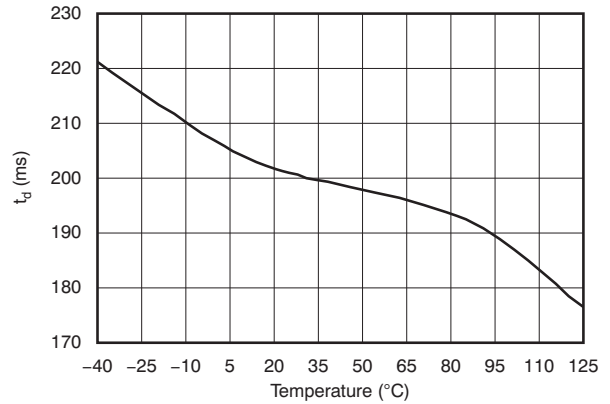

Figure 6.

## APPLICATION INFORMATION

### V<sub>DD</sub> TRANSIENT REJECTION

The TLV810 has built-in rejection of fast transients on the V<sub>DD</sub> pin. The rejection of transients depends on both the duration and the amplitude of the transient. The amplitude of the transient is measured from the bottom of the transient to the negative threshold voltage of the TLV810, as shown in Figure 7.

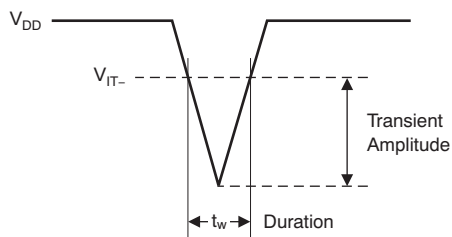

Figure 7. Voltage Transient Measurement

The TLV810 does not respond to transients that are fast duration/low amplitude or long duration/small amplitude. Figure 5 shows the relationship between the transient amplitude and the duration needed to trigger a reset. Any combination of duration and amplitude above the curve generates a reset signal.

### RESET DURING POWER UP/DOWN

The TLV810 output is valid when V<sub>DD</sub> is greater than 1.1 V. When V<sub>DD</sub> is less than 1.1 V, the output is undefined. Figure 8 shows a typical waveform for the power-up sequence.

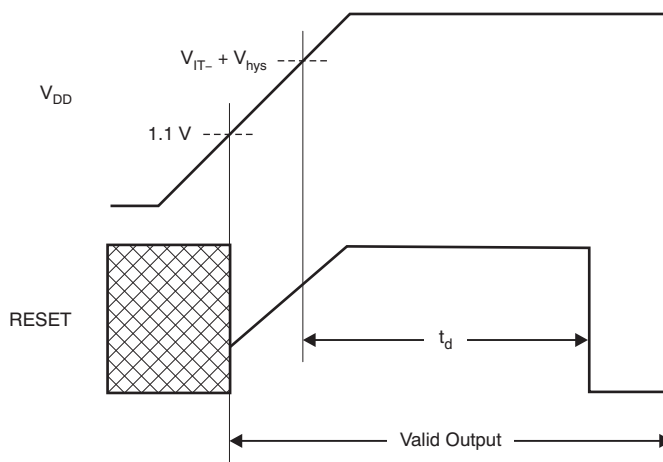
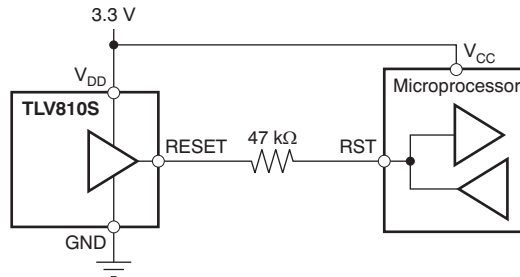

Figure 8. Power-Up Response

## BIDIRECTIONAL RESET PINS

Some microcontrollers have bidirectional reset pins that act as both inputs and outputs. In a situation where both the TLV810 and the microcontroller are attempting to drive the RESET line, a series resistor should be placed between the output of the TLV810 and the RESET pin of the microcontroller to protect against excessive current flow. Figure 9 shows the connection of the TLV810 to a microcontroller using a series resistor to drive a bidirectional RESET line.



**Figure 9. Connection to Bidirectional Reset Pin**

**PACKAGING INFORMATION**

Orderable Device	Status (1)	Package Type	Package Drawing	Pins	Package Qty	Eco Plan (2)	Lead/Ball Finish	MSL Peak Temp (3)	Op Temp (°C)	Top-Side Markings (4)	Samples
TLV810MDBZR	ACTIVE	SOT-23	DBZ	3	3000	Green (RoHS & no Sb/Br)	CU NIPDAU	Level-1-260C-UNLIM	-40 to 125	VOYQ	<a href="#">Samples</a>
TLV810MDBZT	ACTIVE	SOT-23	DBZ	3	250	Green (RoHS & no Sb/Br)	CU NIPDAU	Level-1-260C-UNLIM	-40 to 125	VOYQ	<a href="#">Samples</a>
TLV810RDBZR	ACTIVE	SOT-23	DBZ	3	3000	Green (RoHS & no Sb/Br)	CU NIPDAU	Level-1-260C-UNLIM	-40 to 125	VOWQ	<a href="#">Samples</a>
TLV810RDBZT	ACTIVE	SOT-23	DBZ	3	250	Green (RoHS & no Sb/Br)	CU NIPDAU	Level-1-260C-UNLIM	-40 to 125	VOWQ	<a href="#">Samples</a>
TLV810SDBZR	ACTIVE	SOT-23	DBZ	3	3000	Green (RoHS & no Sb/Br)	CU NIPDAU	Level-1-260C-UNLIM	-40 to 125	VOXQ	<a href="#">Samples</a>
TLV810SDBZT	ACTIVE	SOT-23	DBZ	3	250	Green (RoHS & no Sb/Br)	CU NIPDAU	Level-1-260C-UNLIM	-40 to 125	VOXQ	<a href="#">Samples</a>
TLV810ZDBZR	ACTIVE	SOT-23	DBZ	3	3000	Green (RoHS & no Sb/Br)	CU NIPDAU	Level-1-260C-UNLIM	-40 to 125	VOVQ	<a href="#">Samples</a>
TLV810ZDBZT	ACTIVE	SOT-23	DBZ	3	250	Green (RoHS & no Sb/Br)	CU NIPDAU	Level-1-260C-UNLIM	-40 to 125	VOVQ	<a href="#">Samples</a>

(1) The marketing status values are defined as follows:

**ACTIVE:** Product device recommended for new designs.

**LIFEBUY:** TI has announced that the device will be discontinued, and a lifetime-buy period is in effect.

**NRND:** Not recommended for new designs. Device is in production to support existing customers, but TI does not recommend using this part in a new design.

**PREVIEW:** Device has been announced but is not in production. Samples may or may not be available.

**OBSOLETE:** TI has discontinued the production of the device.

(2) Eco Plan - The planned eco-friendly classification: Pb-Free (RoHS), Pb-Free (RoHS Exempt), or Green (RoHS & no Sb/Br) - please check <http://www.ti.com/productcontent> for the latest availability information and additional product content details.

**TBD:** The Pb-Free/Green conversion plan has not been defined.

**Pb-Free (RoHS):** TI's terms "Lead-Free" or "Pb-Free" mean semiconductor products that are compatible with the current RoHS requirements for all 6 substances, including the requirement that lead not exceed 0.1% by weight in homogeneous materials. Where designed to be soldered at high temperatures, TI Pb-Free products are suitable for use in specified lead-free processes.

**Pb-Free (RoHS Exempt):** This component has a RoHS exemption for either 1) lead-based flip-chip solder bumps used between the die and package, or 2) lead-based die adhesive used between the die and leadframe. The component is otherwise considered Pb-Free (RoHS compatible) as defined above.

**Green (RoHS & no Sb/Br):** TI defines "Green" to mean Pb-Free (RoHS compatible), and free of Bromine (Br) and Antimony (Sb) based flame retardants (Br or Sb do not exceed 0.1% by weight in homogeneous material)

(3) MSL, Peak Temp. -- The Moisture Sensitivity Level rating according to the JEDEC industry standard classifications, and peak solder temperature.



<sup>(4)</sup> Multiple Top-Side Markings will be inside parentheses. Only one Top-Side Marking contained in parentheses and separated by a "~" will appear on a device. If a line is indented then it is a continuation of the previous line and the two combined represent the entire Top-Side Marking for that device.

**Important Information and Disclaimer:** The information provided on this page represents TI's knowledge and belief as of the date that it is provided. TI bases its knowledge and belief on information provided by third parties, and makes no representation or warranty as to the accuracy of such information. Efforts are underway to better integrate information from third parties. TI has taken and continues to take reasonable steps to provide representative and accurate information but may not have conducted destructive testing or chemical analysis on incoming materials and chemicals. TI and TI suppliers consider certain information to be proprietary, and thus CAS numbers and other limited information may not be available for release.

In no event shall TI's liability arising out of such information exceed the total purchase price of the TI part(s) at issue in this document sold by TI to Customer on an annual basis.

**TAPE AND REEL INFORMATION**

**QUADRANT ASSIGNMENTS FOR PIN 1 ORIENTATION IN TAPE**

\*All dimensions are nominal

Device	Package Type	Package Drawing	Pins	SPQ	Reel Diameter (mm)	Reel Width W1 (mm)	A0 (mm)	B0 (mm)	K0 (mm)	P1 (mm)	W (mm)	Pin1 Quadrant
TLV810MDBZR	SOT-23	DBZ	3	3000	179.0	8.4	3.15	2.95	1.22	4.0	8.0	Q3
TLV810MDBZT	SOT-23	DBZ	3	250	179.0	8.4	3.15	2.95	1.22	4.0	8.0	Q3
TLV810RDBZR	SOT-23	DBZ	3	3000	179.0	8.4	3.15	2.95	1.22	4.0	8.0	Q3
TLV810RDBZT	SOT-23	DBZ	3	250	179.0	8.4	3.15	2.95	1.22	4.0	8.0	Q3
TLV810SDBZR	SOT-23	DBZ	3	3000	179.0	8.4	3.15	2.95	1.22	4.0	8.0	Q3
TLV810SDBZT	SOT-23	DBZ	3	250	179.0	8.4	3.15	2.95	1.22	4.0	8.0	Q3
TLV810ZDBZR	SOT-23	DBZ	3	3000	179.0	8.4	3.15	2.95	1.22	4.0	8.0	Q3
TLV810ZDBZT	SOT-23	DBZ	3	250	179.0	8.4	3.15	2.95	1.22	4.0	8.0	Q3

**TAPE AND REEL BOX DIMENSIONS**

\*All dimensions are nominal

Device	Package Type	Package Drawing	Pins	SPQ	Length (mm)	Width (mm)	Height (mm)
TLV810MDBZR	SOT-23	DBZ	3	3000	203.0	203.0	35.0
TLV810MDBZT	SOT-23	DBZ	3	250	203.0	203.0	35.0
TLV810RDBZR	SOT-23	DBZ	3	3000	203.0	203.0	35.0
TLV810RDBZT	SOT-23	DBZ	3	250	203.0	203.0	35.0
TLV810SDBZR	SOT-23	DBZ	3	3000	203.0	203.0	35.0
TLV810SDBZT	SOT-23	DBZ	3	250	203.0	203.0	35.0
TLV810ZDBZR	SOT-23	DBZ	3	3000	203.0	203.0	35.0
TLV810ZDBZT	SOT-23	DBZ	3	250	203.0	203.0	35.0

DBZ (R-PDSO-G3)

PLASTIC SMALL-OUTLINE



- NOTES:
- A. All linear dimensions are in millimeters. Dimensioning and tolerancing per ASME Y14.5M-1994.
  - B. This drawing is subject to change without notice.
  - C. Lead dimensions are inclusive of plating.
  - D. Body dimensions are exclusive of mold flash and protrusion. Mold flash and protrusion not to exceed 0.25 per side.
- Falls within JEDEC TO-236 variation AB, except minimum foot length.

DBZ (R-PDSO-G3)

PLASTIC SMALL OUTLINE

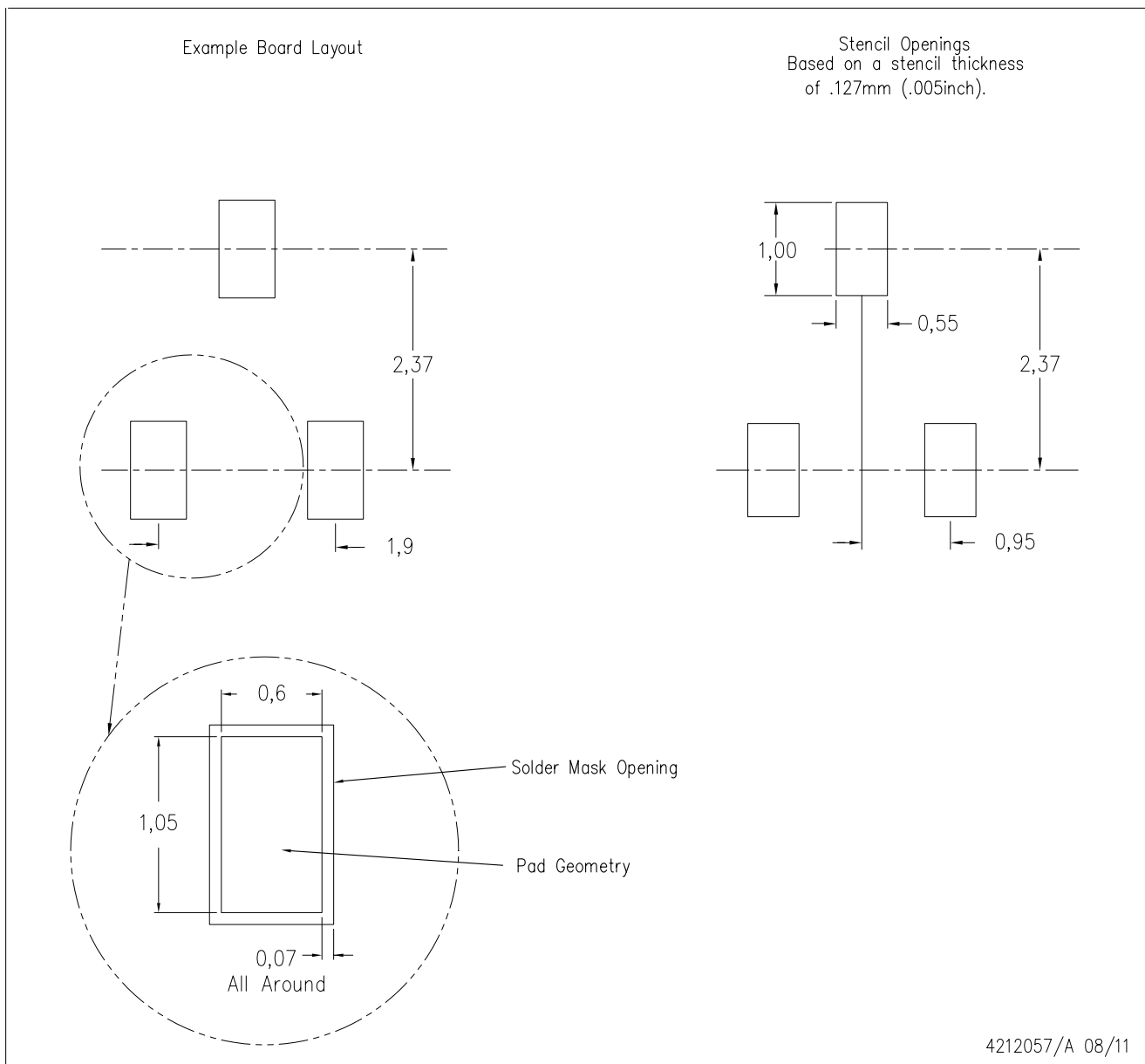

- NOTES:
- A. All linear dimensions are in millimeters.
  - B. This drawing is subject to change without notice.
  - C. Customers should place a note on the circuit board fabrication drawing not to alter the center solder mask defined pad.
  - D. Publication IPC-7351 is recommended for alternate designs.
  - E. Laser cutting apertures with trapezoidal walls and also rounding corners will offer better paste release. Customers should contact their board assembly site for stencil design recommendations. Example stencil design based on a 50% volumetric metal load solder paste. Refer to IPC-7525 for other stencil recommendations.

## IMPORTANT NOTICE

Texas Instruments Incorporated and its subsidiaries (TI) reserve the right to make corrections, enhancements, improvements and other changes to its semiconductor products and services per JESD46, latest issue, and to discontinue any product or service per JESD48, latest issue. Buyers should obtain the latest relevant information before placing orders and should verify that such information is current and complete. All semiconductor products (also referred to herein as "components") are sold subject to TI's terms and conditions of sale supplied at the time of order acknowledgment.

TI warrants performance of its components to the specifications applicable at the time of sale, in accordance with the warranty in TI's terms and conditions of sale of semiconductor products. Testing and other quality control techniques are used to the extent TI deems necessary to support this warranty. Except where mandated by applicable law, testing of all parameters of each component is not necessarily performed.

TI assumes no liability for applications assistance or the design of Buyers' products. Buyers are responsible for their products and applications using TI components. To minimize the risks associated with Buyers' products and applications, Buyers should provide adequate design and operating safeguards.

TI does not warrant or represent that any license, either express or implied, is granted under any patent right, copyright, mask work right, or other intellectual property right relating to any combination, machine, or process in which TI components or services are used. Information published by TI regarding third-party products or services does not constitute a license to use such products or services or a warranty or endorsement thereof. Use of such information may require a license from a third party under the patents or other intellectual property of the third party, or a license from TI under the patents or other intellectual property of TI.

Reproduction of significant portions of TI information in TI data books or data sheets is permissible only if reproduction is without alteration and is accompanied by all associated warranties, conditions, limitations, and notices. TI is not responsible or liable for such altered documentation. Information of third parties may be subject to additional restrictions.

Resale of TI components or services with statements different from or beyond the parameters stated by TI for that component or service voids all express and any implied warranties for the associated TI component or service and is an unfair and deceptive business practice. TI is not responsible or liable for any such statements.

Buyer acknowledges and agrees that it is solely responsible for compliance with all legal, regulatory and safety-related requirements concerning its products, and any use of TI components in its applications, notwithstanding any applications-related information or support that may be provided by TI. Buyer represents and agrees that it has all the necessary expertise to create and implement safeguards which anticipate dangerous consequences of failures, monitor failures and their consequences, lessen the likelihood of failures that might cause harm and take appropriate remedial actions. Buyer will fully indemnify TI and its representatives against any damages arising out of the use of any TI components in safety-critical applications.

In some cases, TI components may be promoted specifically to facilitate safety-related applications. With such components, TI's goal is to help enable customers to design and create their own end-product solutions that meet applicable functional safety standards and requirements. Nonetheless, such components are subject to these terms.

No TI components are authorized for use in FDA Class III (or similar life-critical medical equipment) unless authorized officers of the parties have executed a special agreement specifically governing such use.

Only those TI components which TI has specifically designated as military grade or "enhanced plastic" are designed and intended for use in military/aerospace applications or environments. Buyer acknowledges and agrees that any military or aerospace use of TI components which have **not** been so designated is solely at the Buyer's risk, and that Buyer is solely responsible for compliance with all legal and regulatory requirements in connection with such use.

TI has specifically designated certain components as meeting ISO/TS16949 requirements, mainly for automotive use. In any case of use of non-designated products, TI will not be responsible for any failure to meet ISO/TS16949.

### Products

Audio	<a href="http://www.ti.com/audio">www.ti.com/audio</a>
Amplifiers	<a href="http://amplifier.ti.com">amplifier.ti.com</a>
Data Converters	<a href="http://dataconverter.ti.com">dataconverter.ti.com</a>
DLP® Products	<a href="http://www.dlp.com">www.dlp.com</a>
DSP	<a href="http://dsp.ti.com">dsp.ti.com</a>
Clocks and Timers	<a href="http://www.ti.com/clocks">www.ti.com/clocks</a>
Interface	<a href="http://interface.ti.com">interface.ti.com</a>
Logic	<a href="http://logic.ti.com">logic.ti.com</a>
Power Mgmt	<a href="http://power.ti.com">power.ti.com</a>
Microcontrollers	<a href="http://microcontroller.ti.com">microcontroller.ti.com</a>
RFID	<a href="http://www.ti-rfid.com">www.ti-rfid.com</a>
OMAP Applications Processors	<a href="http://www.ti.com/omap">www.ti.com/omap</a>
Wireless Connectivity	<a href="http://www.ti.com/wirelessconnectivity">www.ti.com/wirelessconnectivity</a>

### Applications

Automotive and Transportation	<a href="http://www.ti.com/automotive">www.ti.com/automotive</a>
Communications and Telecom	<a href="http://www.ti.com/communications">www.ti.com/communications</a>
Computers and Peripherals	<a href="http://www.ti.com/computers">www.ti.com/computers</a>
Consumer Electronics	<a href="http://www.ti.com/consumer-apps">www.ti.com/consumer-apps</a>
Energy and Lighting	<a href="http://www.ti.com/energy">www.ti.com/energy</a>
Industrial	<a href="http://www.ti.com/industrial">www.ti.com/industrial</a>
Medical	<a href="http://www.ti.com/medical">www.ti.com/medical</a>
Security	<a href="http://www.ti.com/security">www.ti.com/security</a>
Space, Avionics and Defense	<a href="http://www.ti.com/space-avionics-defense">www.ti.com/space-avionics-defense</a>
Video and Imaging	<a href="http://www.ti.com/video">www.ti.com/video</a>

### TI E2E Community

[e2e.ti.com](http://e2e.ti.com)