

TLV5627C, TLV5627I

2.7-V TO 5.5-V 8-BIT 4-CHANNEL DIGITAL-TO-ANALOG CONVERTERS WITH POWER DOWN

SLAS232A – JUNE 1999 – REVISED JULY 2002

- Four 8-Bit D/A Converters
- Programmable Settling Time of 2.5 μ s or 8.5 μ s Typ
- TMS320, (Q)SPI™, and Microwire™ Compatible Serial Interface
- Low Power Consumption:
7 mW, Slow Mode – 5-V Supply
3 mW, Slow Mode – 3-V Supply
- Reference Input Buffers
- Monotonic Over Temperature
- Dual 2.7-V to 5.5-V Supply (Separate Digital and Analog Supplies)

- Hardware Power Down
- Software Power Down
- Simultaneous Update

applications

- Battery Powered Test Instruments
- Digital Offset and Gain Adjustment
- Industrial Process Controls
- Machine and Motion Control Devices
- Arbitrary Waveform Generation

description

The TLV5627 is a four channel, 8-bit voltage output digital-to-analog converter (DAC) with a flexible 4-wire serial interface. The 4-wire serial interface allows glueless interface to TMS320, SPI, QSPI, and Microwire serial ports. The TLV5627 is programmed with a 16-bit serial word comprised of a DAC address, individual DAC control bits, and an 8-bit DAC value.

The device has provision for two supplies: one digital supply for the serial interface (via pins DV_{DD} and DGND), and one for the DACs, reference buffers and output buffers (via pins AV_{DD} and AGND). Each supply is independent of the other, and can be any value between 2.7 V and 5.5 V. The dual supplies allow a typical application where the DAC will be controlled via a microprocessor operating on a 3-V supply (also used on pins DV_{DD} and DGND), with the DACs operating on a 5-V supply. The digital and analog supplies can be tied together.

The resistor string output voltage is buffered by an x2 gain rail-to-rail output buffer. The buffer features a Class AB output stage to improve stability and reduce settling time. A rail-to-rail output stage and a power-down mode make it ideal for single voltage, battery based applications. The settling time of the DAC is programmable to allow the designer to optimize speed versus power dissipation. The settling time is chosen by the control bits within the 16-bit serial input string. A high-impedance buffer is integrated on the REFINAB and REFINCD terminals to reduce the need for a low source impedance drive to the terminal. REFINAB and REFINCD allow DACs A and B to have a different reference voltage than DACs C and D.

The device, implemented with a CMOS process, is available in 16-terminal SOIC and TSSOP packages. The TLV5627C is characterized for operation from 0°C to 70°C. The TLV5627I is characterized for operation from –40°C to 85°C.

D OR PW PACKAGE
(TOP VIEW)

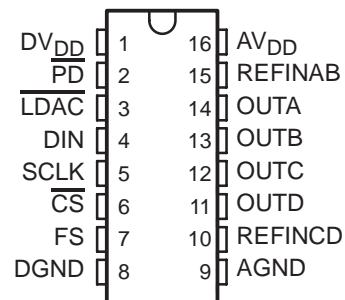

Please be aware that an important notice concerning availability, standard warranty, and use in critical applications of Texas Instruments semiconductor products and disclaimers thereto appears at the end of this data sheet.

SPI and QSPI are trademarks of Motorola, Inc.
Microwire is a trademark of National Semiconductor Corporation.

PRODUCTION DATA information is current as of publication date. Products conform to specifications per the terms of Texas Instruments standard warranty. Production processing does not necessarily include testing of all parameters.



POST OFFICE BOX 655303 • DALLAS, TEXAS 75265

Copyright © 2002, Texas Instruments Incorporated

TLV5627C, TLV5627I

2.7-V TO 5.5-V 8-BIT 4-CHANNEL DIGITAL-TO-ANALOG CONVERTERS WITH POWER DOWN

SLAS232A – JUNE 1999 – REVISED JULY 2002

AVAILABLE OPTIONS

T _A	PACKAGE	
	SOIC (D)	TSSOP (PW)
0°C to 70°C	TLV5627CD	TLV5627CPW
-40°C to 85°C	TLV5627ID	TLV5627IPW

functional block diagram

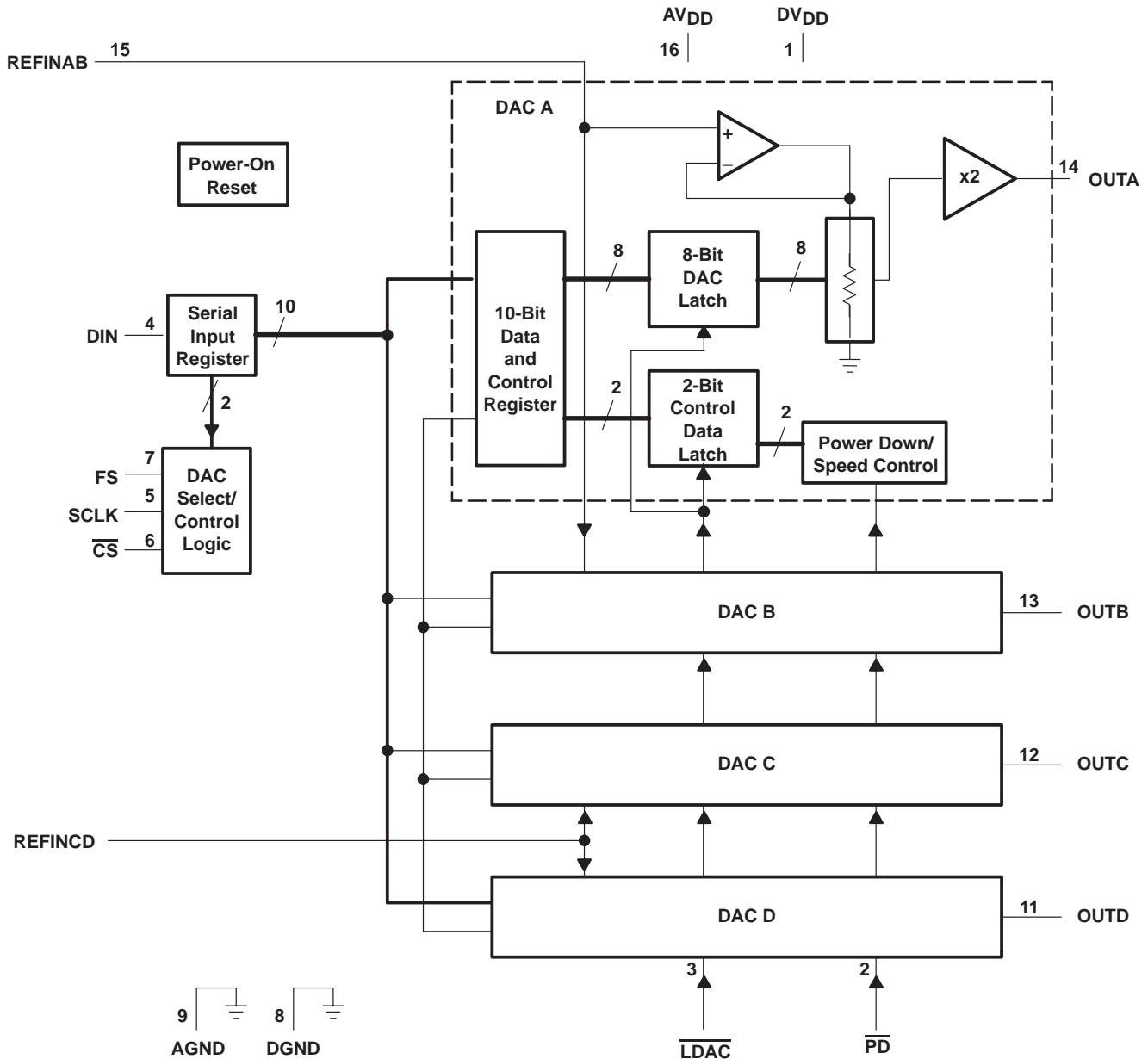

POST OFFICE BOX 655303 • DALLAS, TEXAS 75265

TLV5627C, TLV5627I
2.7-V TO 5.5-V 8-BIT 4-CHANNEL DIGITAL-TO-ANALOG CONVERTERS
WITH POWER DOWN

SLAS232A – JUNE 1999 – REVISED JULY 2002

Terminal Functions

TERMINAL NAME	NO.	I/O	DESCRIPTION
AGND	9		Analog ground
AV _{DD}	16		Analog supply
$\overline{\text{CS}}$	6	I	Chip select. This terminal is active low.
DGND	8		Digital ground
DIN	4	I	Serial data input
DV _{DD}	1		Digital supply
FS	7	I	Frame sync input. The falling edge of the frame sync pulse indicates the start of a serial data frame shifted out to the TLV5627.
$\overline{\text{PD}}$	2	I	Power-down pin. Powers down all DACs (overriding their individual power down settings), and all output stages. This terminal is active low.
$\overline{\text{LDAC}}$	3	I	Load DAC. When the $\overline{\text{LDAC}}$ signal is high, no DAC output updates occur when the input digital data is read into the serial interface. The DAC outputs are only updated when LDAC is low.
REFINAB	15	I	Voltage reference input for DACs A and B.
REFINCD	10	I	Voltage reference input for DACs C and D.
SCLK	5	I	Serial clock input
OUTA	14	O	DAC A output
OUTB	13	O	DAC B output
OUTC	12	O	DAC C output
OUTD	11	O	DAC D output

absolute maximum ratings over operating free-air temperature range (unless otherwise noted)†

Supply voltage, (DV _{DD} , AV _{DD} to GND)	7 V
Supply voltage difference, (AV _{DD} to DV _{DD})	–2.8 V to 2.8 V
Digital input voltage range	–0.3 V to DV _{DD} + 0.3 V
Reference input voltage range	–0.3 V to AV _{DD} + 0.3 V
Operating free-air temperature range, T _A : TLV5627C	0°C to 70°C
TLV5627I	–40°C to 85°C
Storage temperature range, T _{stg}	–65°C to 150°C
Lead temperature 1,6 mm (1/16 inch) from case for 10 seconds	260°C

† Stresses beyond those listed under “absolute maximum ratings” may cause permanent damage to the device. These are stress ratings only, and functional operation of the device at these or any other conditions beyond those indicated under “recommended operating conditions” is not implied. Exposure to absolute-maximum-rated conditions for extended periods may affect device reliability.



TLV5627C, TLV5627I

2.7-V TO 5.5-V 8-BIT 4-CHANNEL DIGITAL-TO-ANALOG CONVERTERS WITH POWER DOWN

SLAS232A – JUNE 1999 – REVISED JULY 2002

recommended operating conditions

		MIN	NOM	MAX	UNIT
Supply voltage, V_{DD} , DV_{DD}	5-V supply	4.5	5	5.5	V
	3-V supply	2.7	3	3.3	
High-level digital input voltage, V_{IH}	$DV_{DD} = 2.7\text{ V}$	2			V
	$DV_{DD} = 5.5\text{ V}$	2.4			
Low-level digital input voltage, V_{IL}	$DV_{DD} = 2.7\text{ V}$			0.6	V
	$DV_{DD} = 5.5\text{ V}$			1	
Reference voltage, V_{ref} to REFINAB, REFINCD terminal	5-V supply (see Note 1)	0	2.048	$AV_{DD}-1.5$	V
	3-V supply (see Note 1)	0	1.024	$AV_{DD}-1.5$	
Load resistance, R_L		2	10		k Ω
Load capacitance, C_L				100	pF
Serial clock rate, SCLK				20	MHz
Operating free-air temperature	TLV5627C	0		70	$^{\circ}\text{C}$
	TLV5627I	-40		85	

NOTE 1: Voltages greater than $AV_{DD}/2$ will cause output saturation for large DAC codes.

electrical characteristics over recommended operating free-air temperature range (unless otherwise noted)

static DAC specifications

PARAMETER		TEST CONDITIONS	MIN	TYP	MAX	UNIT
Resolution			8			bits
Integral nonlinearity (INL), end point adjusted		See Note 2		± 0.3	± 0.5	LSB
Differential nonlinearity (DNL)		See Note 3		± 0.03	± 0.5	LSB
E _{ZS}	Zero scale error (offset error at zero scale)	See Note 4			± 10	mV
Zero scale error temperature coefficient		See Note 5		10		ppm/ $^{\circ}\text{C}$
E _G	Gain error	See Note 6			± 0.6	% of FS voltage
Gain error temperature coefficient		See Note 7		10		ppm/ $^{\circ}\text{C}$

- NOTES:
- The relative accuracy or integral nonlinearity (INL) sometimes referred to as linearity error, is the maximum deviation of the output from the line between zero and full scale excluding the effects of zero code and full-scale errors.
 - The differential nonlinearity (DNL) sometimes referred to as differential error, is the difference between the measured and ideal 1 LSB amplitude change of any two adjacent codes. Monotonic means the output voltage changes in the same direction (or remains constant) as a change in the digital input code.
 - Zero-scale error is the deviation from zero voltage output when the digital input code is zero.
 - Zero-scale-error temperature coefficient is given by: $E_{ZS\ TC} = [E_{ZS}(T_{max}) - E_{ZS}(T_{min})]/V_{ref} \times 10^6/(T_{max} - T_{min})$.
 - Gain error is the deviation from the ideal output ($2V_{ref} - 1\text{ LSB}$) with an output load of 10 k Ω excluding the effects of the zero-error.
 - Gain temperature coefficient is given by: $E_{G\ TC} = [E_G(T_{max}) - E_G(T_{min})]/V_{ref} \times 10^6/(T_{max} - T_{min})$.



TLV5627C, TLV5627I

2.7-V TO 5.5-V 8-BIT 4-CHANNEL DIGITAL-TO-ANALOG CONVERTERS WITH POWER DOWN

SLAS232A – JUNE 1999 – REVISED JULY 2002

electrical characteristics over recommended operating free-air temperature range
(unless otherwise noted) (continued)

individual DAC output specifications

PARAMETER	TEST CONDITIONS	MIN	TYP	MAX	UNIT
V_O Voltage output	$R_L = 10\text{ k}\Omega$	0	$AV_{DD}-0.4$		V
Output load regulation accuracy	$R_L = 2\text{ k}\Omega$ vs $10\text{ k}\Omega$		0.1	0.25	% of FS voltage

reference input (REFINAB, REFINCD)

PARAMETER	TEST CONDITIONS	MIN	TYP	MAX	UNIT
V_I Input voltage range	See Note 8	0	$AV_{DD}-1.5$		V
R_I Input resistance			10		$M\Omega$
C_I Input capacitance			5		pF
Reference feed through	$REFIN = 1\text{ V}_{pp}$ at 1 kHz + 1.024 V dc (see Note 9)		-75		dB
Reference input bandwidth	$REFIN = 0.2\text{ V}_{pp} + 1.024\text{ V dc}$	Slow	0.5		MHz
		Fast	1		

NOTES: 8. Reference input voltages greater than $V_{DD}/2$ will cause output saturation for large DAC codes.

9. Reference feedthrough is measured at the DAC output with an input code = 000 hex and a $V_{ref}(REFINAB$ or $REFINCD)$ input = $1.024\text{ Vdc} + 1\text{ V}_{pp}$ at 1 kHz.

digital inputs ($\overline{D0-D11}$, \overline{CS} , \overline{WEB} , \overline{LDAC} , \overline{PD})

PARAMETER	TEST CONDITIONS	MIN	TYP	MAX	UNIT
I_{IH} High-level digital input current	$V_I = DV_{DD}$			± 1	μA
I_{IL} Low-level digital input current	$V_I = 0\text{ V}$			± 1	μA
C_I Input capacitance			3		pF

power supply

PARAMETER	TEST CONDITIONS	MIN	TYP	MAX	UNIT	
I_{DD} Power supply current	5-V supply, No load, Clock running	Slow	1.4	2.2	mA	
		Fast	3.5	5.5		
	3-V supply, No load, Clock running	Slow		1	1.5	mA
		Fast		3	4.5	
Power down supply current, See Figure 12			1		μA	
PSRR Power supply rejection ratio	Zero scale gain			-68	dB	
	Gain	See Notes 10 and 11		-68		

10. Zero-scale-error rejection ratio (EZR-RR) is measured by varying the AV_{DD} from $5 \pm 0.5\text{ V}$ and $3 \pm 0.3\text{ V dc}$, and measuring the proportion of this signal imposed on the zero-code output voltage.

11. Gain-error rejection ratio (EG-RR) is measured by varying the AV_{DD} from $5 \pm 0.5\text{ V}$ and $3 \pm 0.3\text{ V dc}$ and measuring the proportion of this signal imposed on the full-scale output voltage after subtracting the zero scale change.



TLV5627C, TLV5627I

2.7-V TO 5.5-V 8-BIT 4-CHANNEL DIGITAL-TO-ANALOG CONVERTERS WITH POWER DOWN

SLAS232A – JUNE 1999 – REVISED JULY 2002

electrical characteristics over recommended operating free-air temperature range (unless otherwise noted) (continued)

analog output dynamic performance

PARAMETER		TEST CONDITIONS	MIN	TYP	MAX	UNIT
SR	Output slew rate	$C_L = 100 \text{ pF}$, $R_L = 10 \text{ k}\Omega$, $V_O = 10\% \text{ to } 90\%$, $V_{ref} = 2.048 \text{ V}, 1024 \text{ V}$	Fast	5		$\text{V}/\mu\text{s}$
			Slow	1		$\text{V}/\mu\text{s}$
t_s	Output settling time	$T_o \pm 0.1 \text{ LSB}$, $C_L = 100 \text{ pF}$, $R_L = 10 \text{ k}\Omega$, See Notes 12 and 14	Fast	2.5	4	μs
			Slow	8.5	18	
$t_{s(c)}$	Output settling time, code to code	$T_o \pm 0.1 \text{ LSB}$, $C_L = 100 \text{ pF}$, $R_L = 10 \text{ k}\Omega$, See Notes 13 and 14	Fast	1		μs
			Slow	2		
Glitch energy		Code transition from 7F0 to 800		10		nV-sec
SNR	Signal-to-noise ratio	Sinewave generated by DAC, Reference voltage = 1.024 at 3 V and 2.048 at 5 V, $f_s = 400 \text{ KSPS}$, $f_{OUT} = 1.1 \text{ kHz}$ sinewave, $C_L = 100 \text{ pF}$, $R_L = 10 \text{ k}\Omega$, $BW = 20 \text{ kHz}$		57		dB
S/(N+D)	Signal to noise + distortion			49		
THD	Total harmonic distortion			-50		
SFDR	Spurious free dynamic range			60		

- NOTES: 12. Settling time is the time for the output signal to remain within $\pm 0.1 \text{ LSB}$ of the final measured value for a digital input code change of 0x020 to 0xFF0 or 0xFF0 to 0x020.
13. Settling time is the time for the output signal to remain within $\pm 0.1 \text{ LSB}$ of the final measured value for a digital input code change of one count.
14. Limits are ensured by design and characterization, but are not production tested.

digital input timing requirements

		MIN	NOM	MAX	UNIT
$t_{su}(\overline{CS}-FS)$	Setup time, \overline{CS} low before $FS\downarrow$	10			ns
$t_{su}(FS-CK)$	Setup time, FS low before first negative SCLK edge	8			ns
$t_{su}(C16-FS)$	Setup time, sixteenth negative SCLK edge after FS low on which bit D0 is sampled before rising edge of FS	10			ns
$t_{su}(C16-CS)$	Setup time. The first positive SCLK edge after D0 is sampled before \overline{CS} rising edge. If FS is used instead of the SCLK positive edge to update the DAC, then the setup time is between the FS rising edge and \overline{CS} rising edge.	10			ns
t_{wH}	Pulse duration, SCLK high	25			ns
t_{wL}	Pulse duration, SCLK low	25			ns
$t_{su}(D)$	Setup time, data ready before SCLK falling edge	8			ns
$t_h(D)$	Hold time, data held valid after SCLK falling edge	5			ns
$t_{wH}(FS)$	Pulse duration, FS high	20			ns

TLV5627C, TLV5627I
2.7-V TO 5.5-V 8-BIT 4-CHANNEL DIGITAL-TO-ANALOG CONVERTERS
WITH POWER DOWN

SLAS232A – JUNE 1999 – REVISED JULY 2002

PARAMETER MEASUREMENT INFORMATION

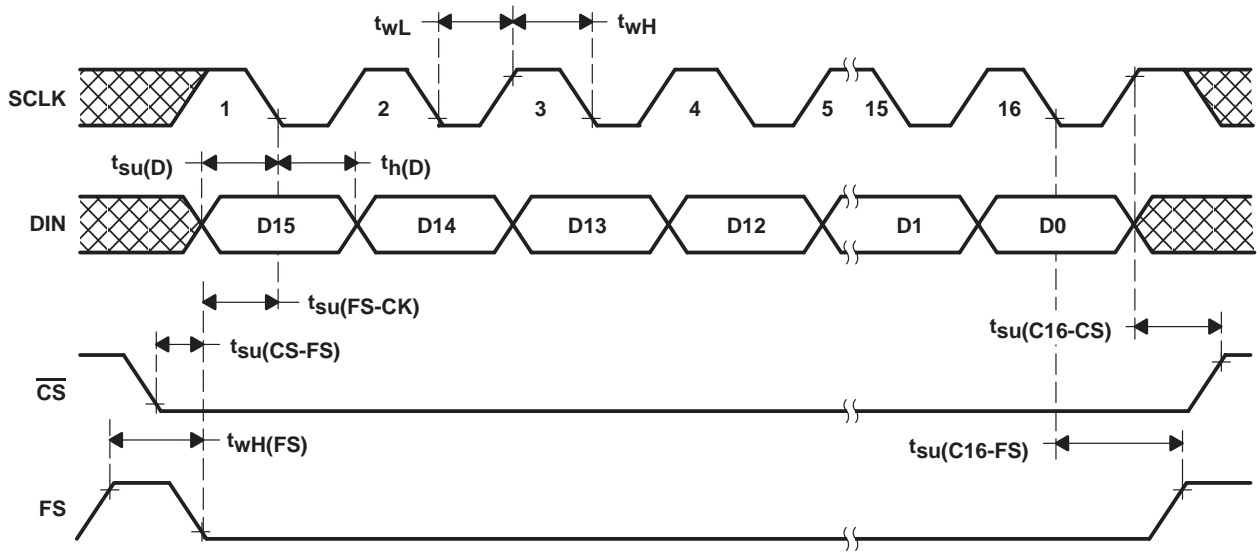

Figure 1. Timing Diagram

TLV5627C, TLV5627I

2.7-V TO 5.5-V 8-BIT 4-CHANNEL DIGITAL-TO-ANALOG CONVERTERS WITH POWER DOWN

SLAS232A – JUNE 1999 – REVISED JULY 2002

TYPICAL CHARACTERISTICS

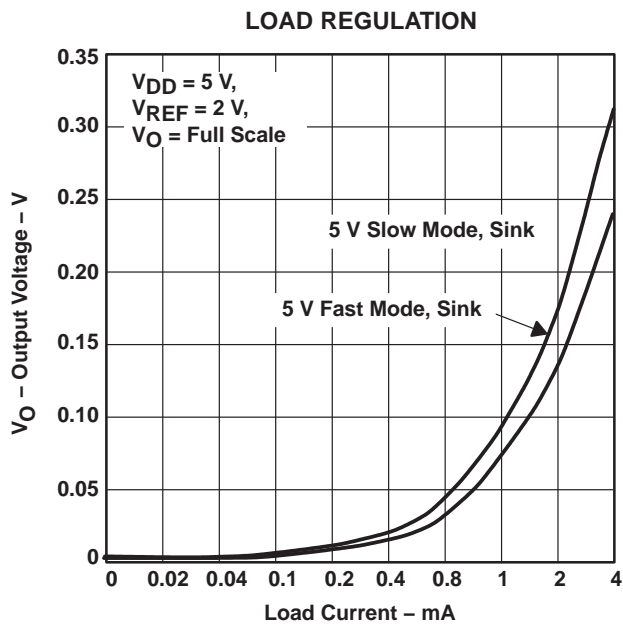

Figure 2

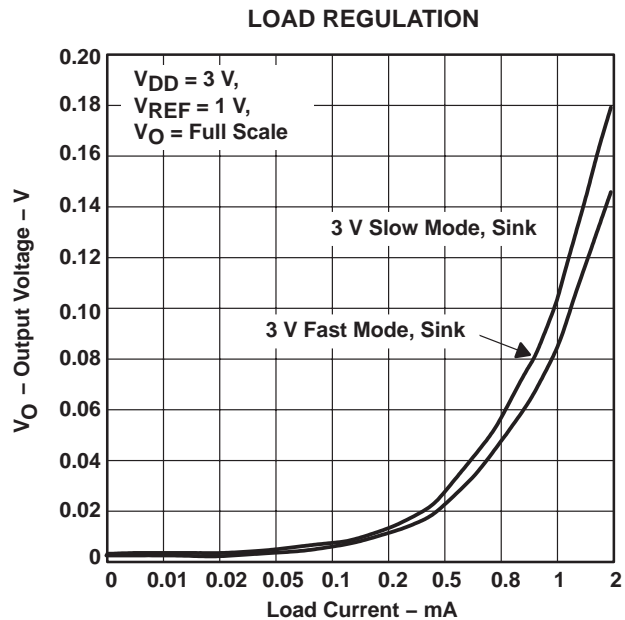

Figure 3

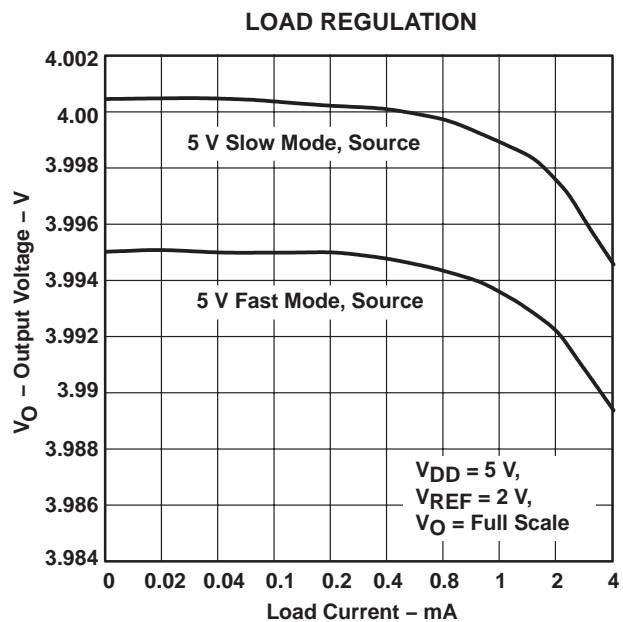

Figure 4

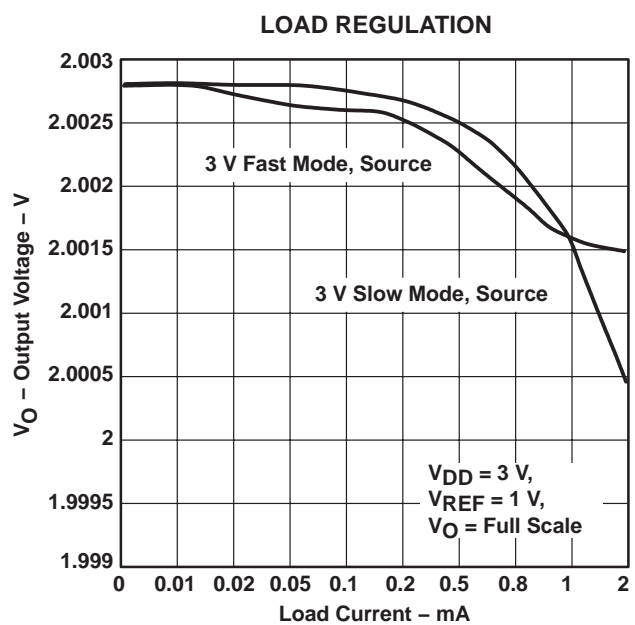

Figure 5



TLV5627C, TLV5627I

2.7-V TO 5.5-V 8-BIT 4-CHANNEL DIGITAL-TO-ANALOG CONVERTERS WITH POWER DOWN

SLAS232A – JUNE 1999 – REVISED JULY 2002

TYPICAL CHARACTERISTICS

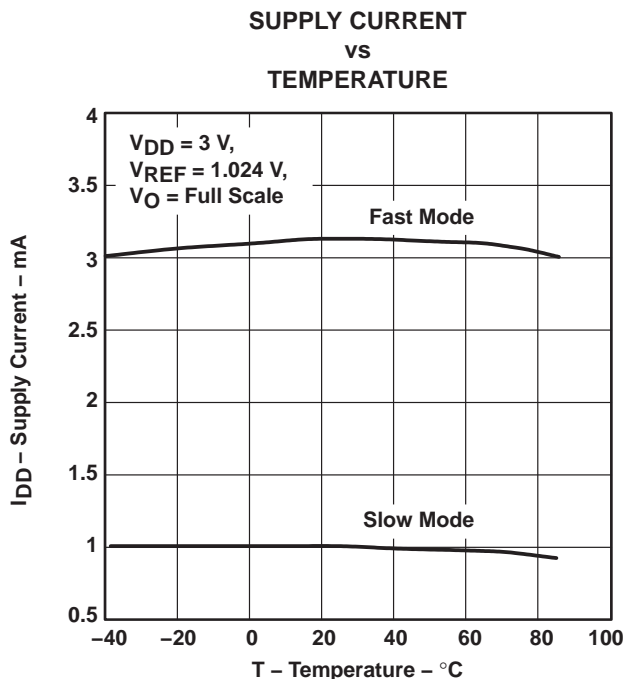

Figure 6

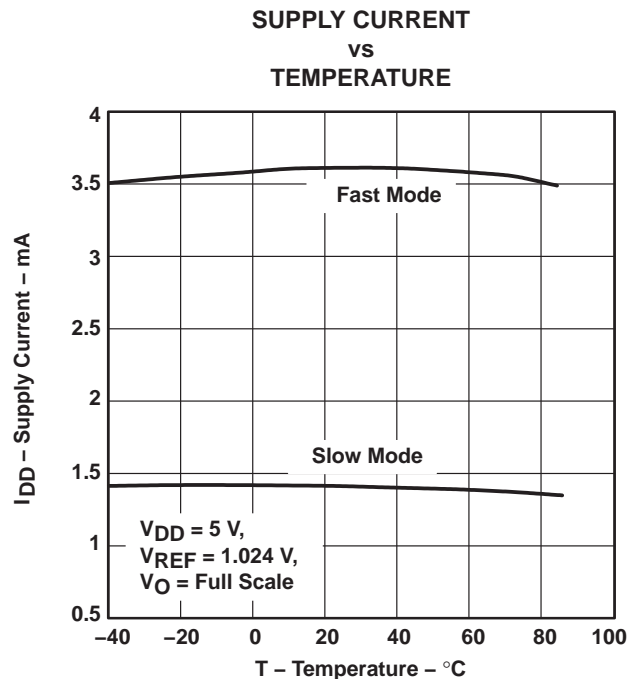

Figure 7

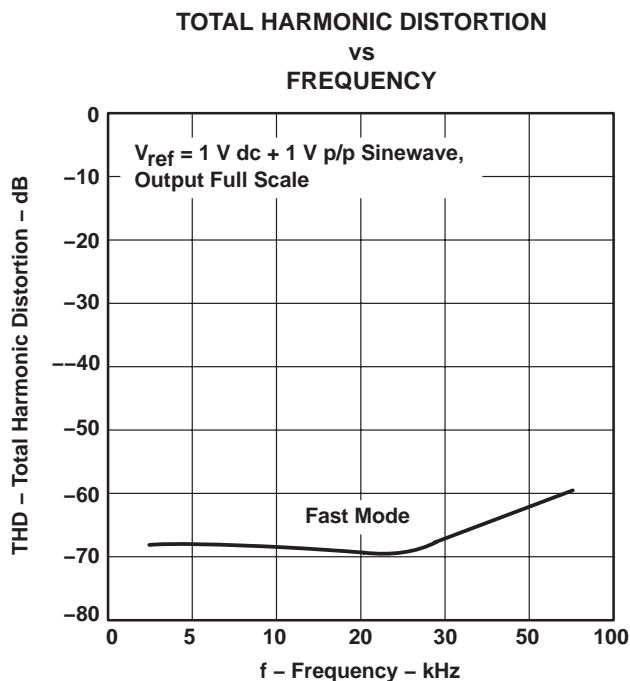

Figure 8

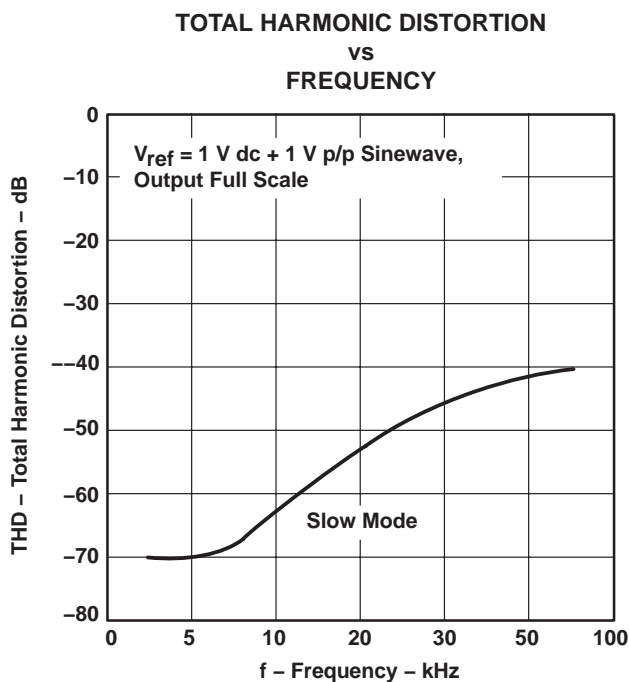

Figure 9

TLV5627C, TLV5627I
2.7-V TO 5.5-V 8-BIT 4-CHANNEL DIGITAL-TO-ANALOG CONVERTERS
WITH POWER DOWN

SLAS232A – JUNE 1999 – REVISED JULY 2002

TYPICAL CHARACTERISTICS

**TOTAL HARMONIC DISTORTION AND NOISE
 VS
 FREQUENCY**

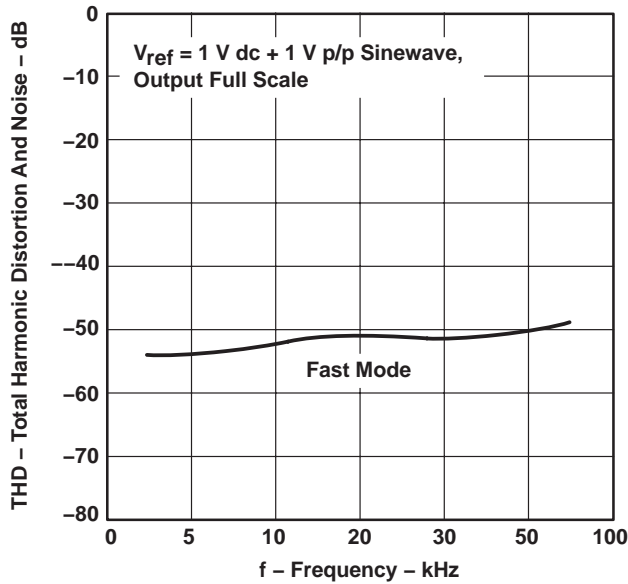

Figure 10

**TOTAL HARMONIC DISTORTION AND NOISE
 VS
 FREQUENCY**

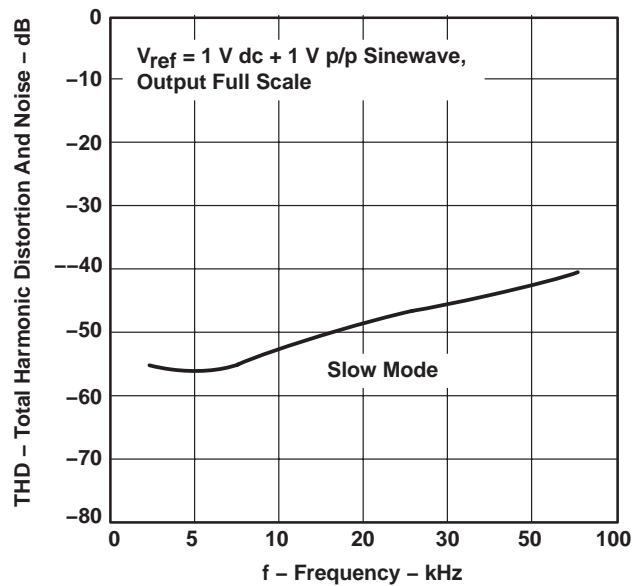

Figure 11

**SUPPLY CURRENT
 VS
 TIME**

(WHEN ENTERING POWER-DOWN MODE)

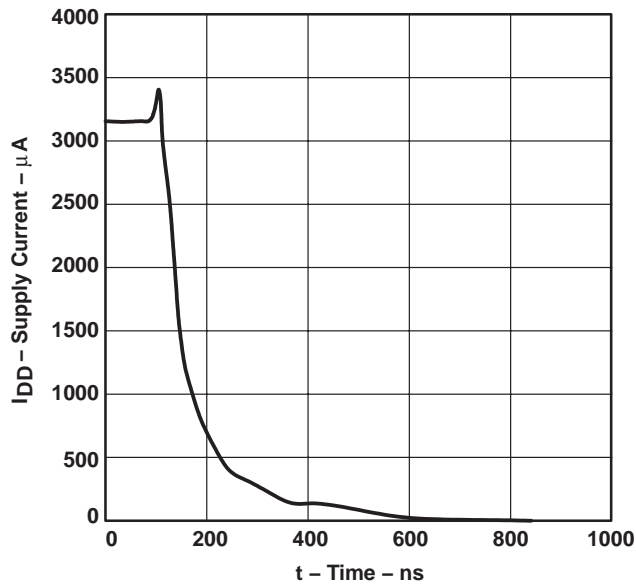

Figure 12

TYPICAL CHARACTERISTICS

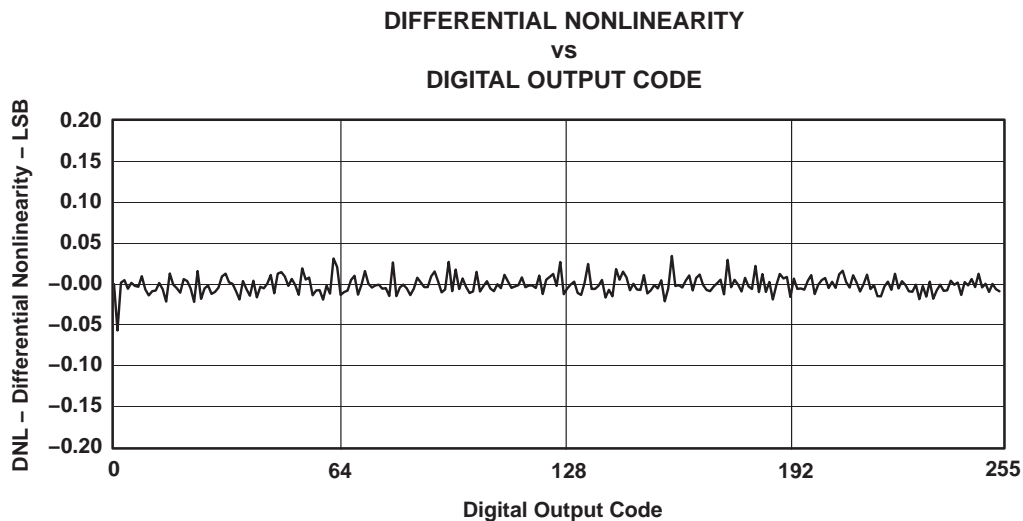

Figure 13

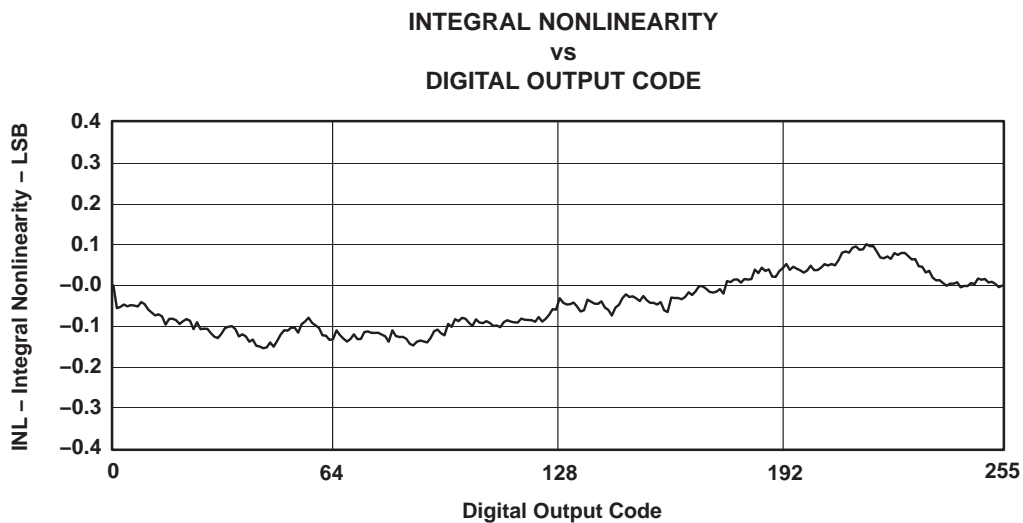

Figure 14

TLV5627C, TLV5627I

2.7-V TO 5.5-V 8-BIT 4-CHANNEL DIGITAL-TO-ANALOG CONVERTERS WITH POWER DOWN

SLAS232A – JUNE 1999 – REVISED JULY 2002

APPLICATION INFORMATION

general function

The TLV5627 is an 8-bit single supply DAC based on a resistor string architecture. The device consists of a serial interface, speed and power-down control logic, a reference input buffer, a resistor string, and a rail-to-rail output buffer.

The output voltage (full scale determined by external reference) is given by:

$$2 \text{ REF} \frac{\text{CODE}}{2^n} \text{ [V]}$$

Where REF is the reference voltage and CODE is the digital input value within the range of 0_{10} to 2^n-1 , where $n=8$ (bits). The 16-bit data word, consisting of control bits and the new DAC value, is illustrated in the *data format* section. A power-on reset initially resets the internal latches to a defined state (all bits zero).

serial interface

The device has to be enabled with $\overline{\text{CS}}$ set to low. A falling edge of FS starts shifting the data bit-per-bit (starting with the MSB) to the internal register on the falling edges of SCLK. After 16 bits have been transferred or FS rises, the content of the shift register is moved to the DAC latch, which updates the voltage output to the new level.

The serial interface of the TLV5627 can be used in two basic modes:

- Four wire (with chip select)
- Three wire (without chip select)

Using chip select (four-wire mode), it is possible to have more than one device connected to the serial port of the data source (DSP or microcontroller). The interface is compatible with the TMS320 family. Figure 15 shows an example with two TLV5627s connected directly to a TMS320 DSP.

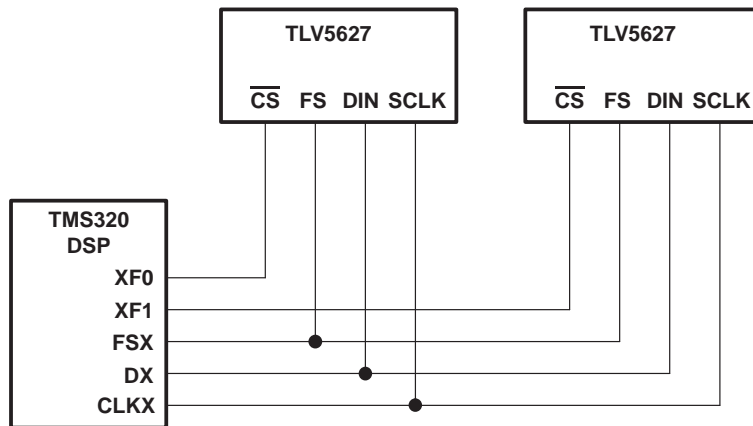

Figure 15. TMS320 Interface

APPLICATION INFORMATION

serial interface (continued)

If there is no need to have more than one device on the serial bus, then \overline{CS} can be tied low. Figure 16 shows an example of how to connect the TLV5627 to a TMS320, SPI, or Microwire port using only three pins.

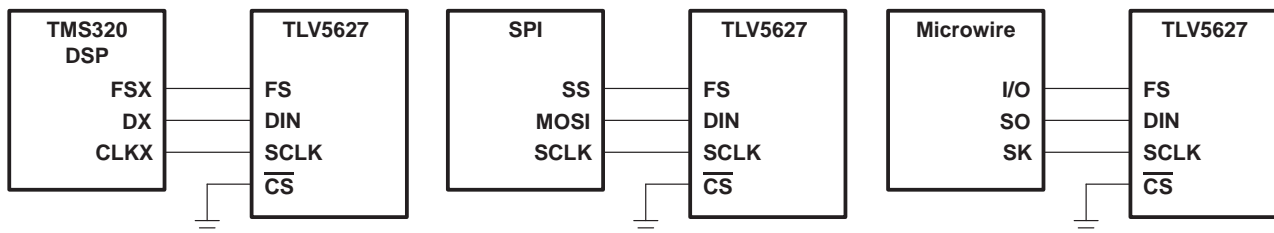

Figure 16. Three-Wire Interface

Notes on SPI and Microwire: Before the controller starts the data transfer, the software has to generate a falling edge on the I/O pin connected to FS. If the word width is 8 bits (SPI and Microwire), two write operations must be performed to program the TLV5627. After the write operation(s), the DAC output is updated automatically on the next positive clock edge following the sixteenth falling clock edge.

serial clock frequency and update rate

The maximum serial clock frequency is given by:

$$f_{SCLKmax} = \frac{1}{t_{wH(min)} + t_{wL(min)}} = 20 \text{ MHz}$$

The maximum update rate is:

$$f_{UPDATEmax} = \frac{1}{16(t_{wH(min)} + t_{wL(min)})} = 1.25 \text{ MHz}$$

The maximum update rate is a theoretical value for the serial interface since the settling time of the TLV5627 has to be considered also.

data format

The 16-bit data word for the TLV5627 consists of two parts:

- Control bits (D15 . . . D12)
- New DAC value (D11 . . . D0)

D15	D14	D13	D12	D11	D10	D9	D8	D7	D6	D5	D4	D3	D2	D1	D0
A1	A0	PWR	SPD	New DAC value (8 bits)								0	0	0	0

SPD: Speed control bit. 1 → fast mode 0 → slow mode
PWR: Power control bit. 1 → power down 0 → normal operation

TLV5627C, TLV5627I

2.7-V TO 5.5-V 8-BIT 4-CHANNEL DIGITAL-TO-ANALOG CONVERTERS WITH POWER DOWN

SLAS232A – JUNE 1999 – REVISED JULY 2002

APPLICATION INFORMATION

In power-down mode, all amplifiers within the TLV5627 are disabled. A particular DAC (A, B, C, D) of the TLV5627 is selected by A1 and A0 within the input word.

A1	A0	DAC
0	0	A
0	1	B
1	0	C
1	1	D

TLV5627 interfaced to TMS320C203 DSP

hardware interfacing

Figure 17 shows an example of how to connect the TLV5627 to a TMS320C203 DSP. The serial port is configured in burst mode, with FSX generated by the TMS320C203 to provide the frame sync (FS) input to the TLV5627. Data is transmitted on the DX line, with the serial clock input on the CLKX line. The general-purpose input/output port bits IO0 and IO1 are used to generate the chip select (\overline{CS}) and DAC latch update (\overline{LDAC}) inputs to the TLV5627. The active low power down (\overline{PD}) is pulled high all the time to ensure the DACs are enabled.

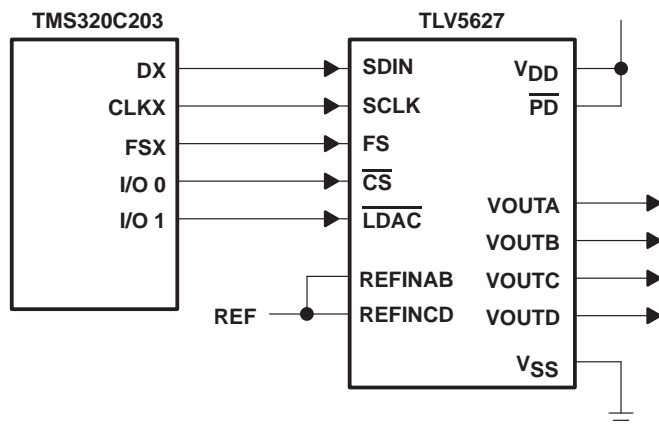

Figure 17. TLV5627 Interfaced with TMS320C203

APPLICATION INFORMATION

TLV5627 interfaced to MCS[®]51 microcontroller

hardware interfacing

Figure 18 shows an example of how to connect the TLV5627 to an MCS[®]51 Microcontroller. The serial DAC input data and external control signals are sent via I/O Port 3 of the controller. The serial data is sent on the RxD line, with the serial clock output on the TxD line. Port 3 bits 3, 4, and 5 are configured as outputs to provide the DAC latch update ($\overline{\text{LDAC}}$), chip select ($\overline{\text{CS}}$) and frame sync (FS) signals for the TLV5627. The active low power down pin ($\overline{\text{PD}}$) of the TLV5627 is pulled high to ensure that the DACs are enabled.

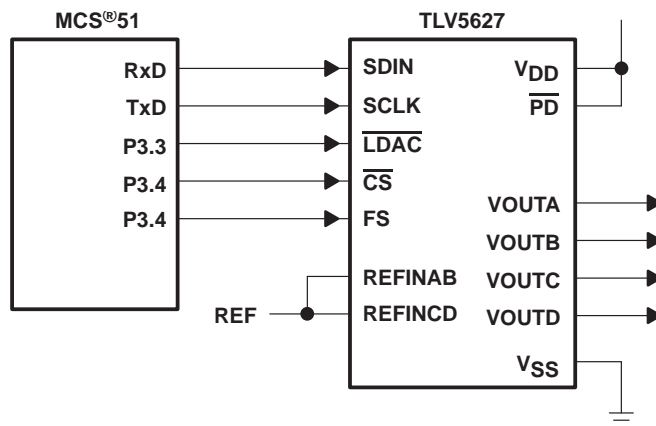

Figure 18. TLV5627 Interfaced with MCS[®]51

linearity, offset, and gain error using single ended supplies

When an amplifier is operated from a single supply, the voltage offset can still be either positive or negative. With a positive offset, the output voltage changes on the first code change. With a negative offset, the output voltage may not change with the first code, depending on the magnitude of the offset voltage.

The output amplifier attempts to drive the output to a negative voltage. However, because the most negative supply rail is ground, the output cannot drive below ground and clamps the output at 0 V.

The output voltage then remains at zero until the input code value produces a sufficient positive output voltage to overcome the negative offset voltage, resulting in the transfer function shown in Figure 19.

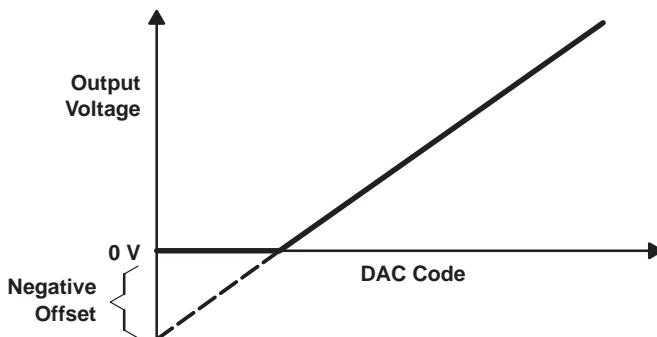

Figure 19. Effect of Negative Offset (single supply)

MCS is a registered trademark of Intel Corporation.

TLV5627C, TLV5627I

2.7-V TO 5.5-V 8-BIT 4-CHANNEL DIGITAL-TO-ANALOG CONVERTERS WITH POWER DOWN

SLAS232A – JUNE 1999 – REVISED JULY 2002

APPLICATION INFORMATION

linearity, offset, and gain error using single ended supplies (continued)

The offset error, not the linearity error, produces this breakpoint. The transfer function would have followed the dotted line if the output buffer could drive below the ground rail.

For a DAC, linearity is measured between zero-input code (all inputs 0) and full-scale code (all inputs 1) after offset and full scale are adjusted out or accounted for in some way. However, single supply operation does not allow for adjustment when the offset is negative due to the breakpoint in the transfer function. So the linearity is measured between full-scale code and the lowest code that produces a positive output voltage.

power-supply bypassing and ground management

Printed-circuit boards that use separate analog and digital ground planes offer the best system performance. Wire-wrap boards do not perform well and should not be used. The two ground planes should be connected together at the low-impedance power-supply source. The best ground connection may be achieved by connecting the DAC AGND terminal to the system analog ground plane, making sure that analog ground currents are well-managed and there are negligible voltage drops across the ground plane.

A 0.1- μF ceramic-capacitor bypass should be connected between V_{DD} and AGND and mounted with short leads as close as possible to the device. Use of ferrite beads may further isolate the system analog supply from the digital power supply.

Figure 20 shows the ground plane layout and bypassing technique.

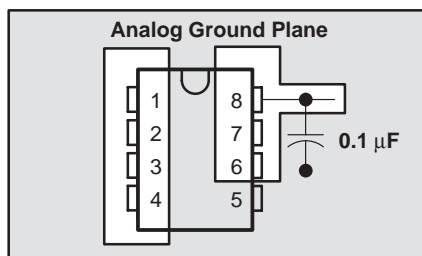

Figure 20. Power-Supply Bypassing

TLV5627C, TLV5627I 2.7-V TO 5.5-V 8-BIT 4-CHANNEL DIGITAL-TO-ANALOG CONVERTERS WITH POWER DOWN

SLAS232A – JUNE 1999 – REVISED JULY 2002

MECHANICAL DATA

D (R-PDSO-G)**

PLASTIC SMALL-OUTLINE PACKAGE

14 PIN SHOWN

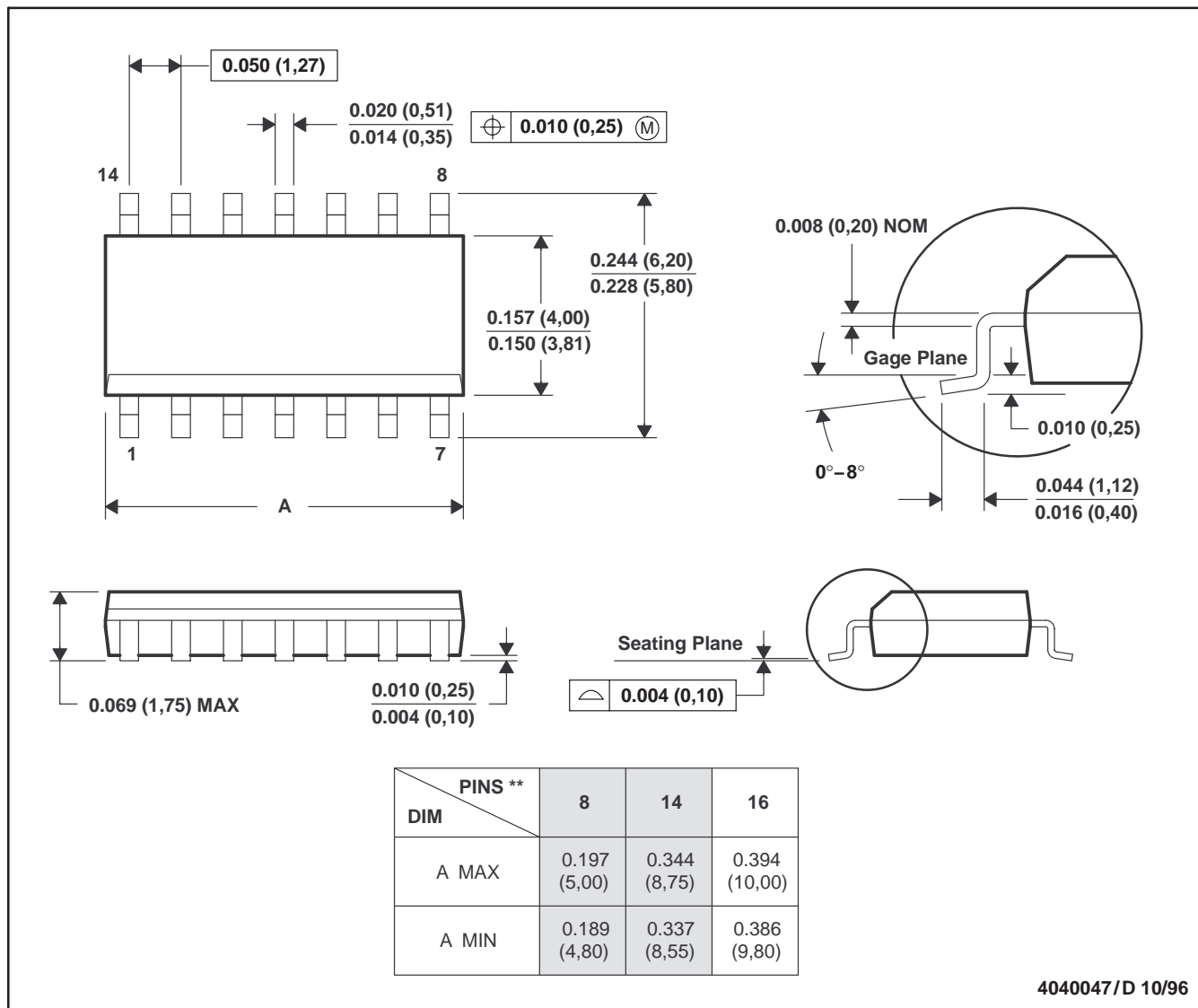

- NOTES: A. All linear dimensions are in inches (millimeters).
 B. This drawing is subject to change without notice.
 C. Body dimensions do not include mold flash or protrusion, not to exceed 0.006 (0,15).
 D. Falls within JEDEC MS-012

TLV5627C, TLV5627I
2.7-V TO 5.5-V 8-BIT 4-CHANNEL DIGITAL-TO-ANALOG CONVERTERS
WITH POWER DOWN

SLAS232A – JUNE 1999 – REVISED JULY 2002

MECHANICAL DATA

PW (R-PDSO-G)**

PLASTIC SMALL-OUTLINE PACKAGE

14 PIN SHOWN

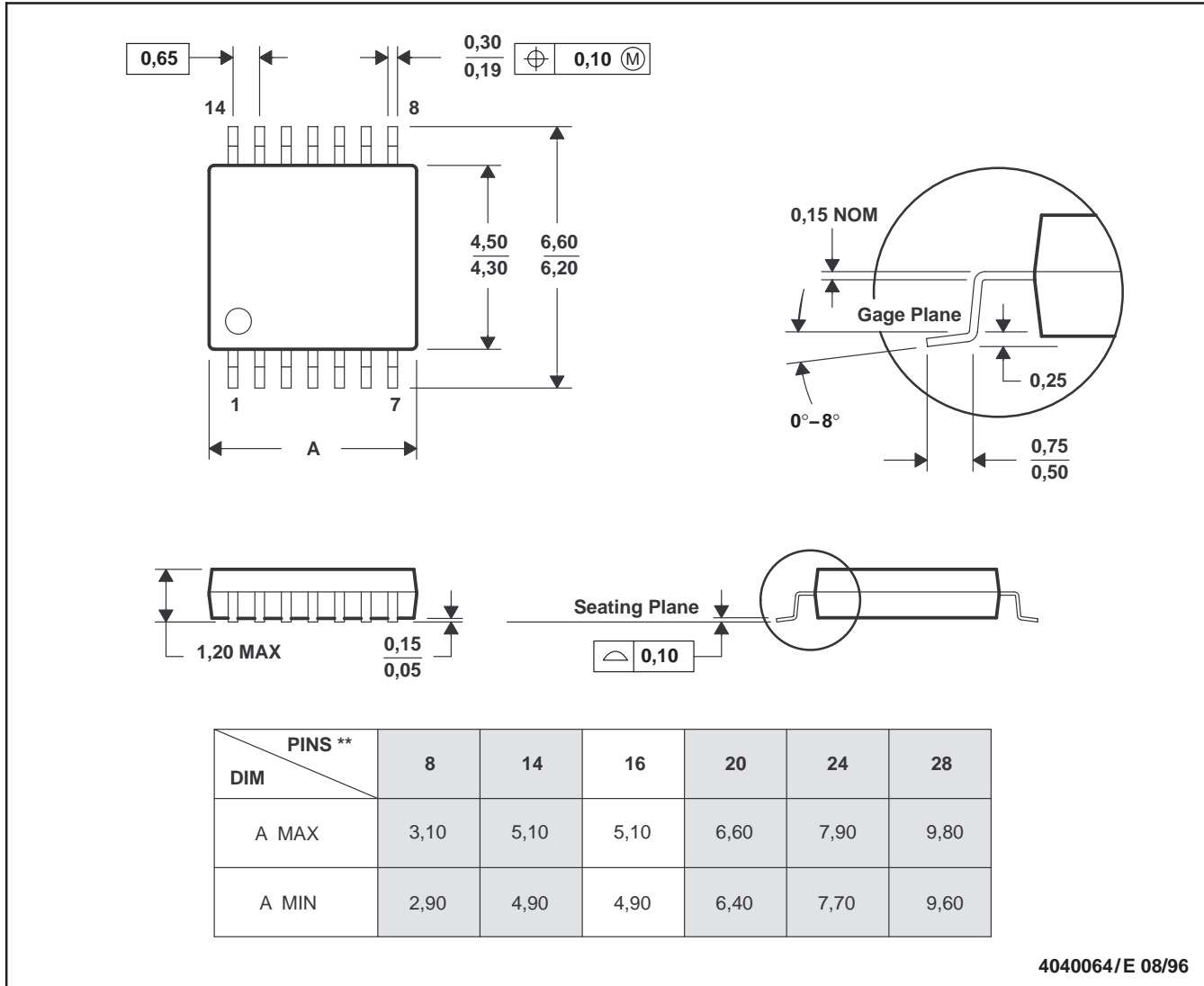

4040064/E 08/96

- NOTES: A. All linear dimensions are in millimeters.
 B. This drawing is subject to change without notice.
 C. Body dimensions do not include mold flash or protrusion not to exceed 0,15.
 D. Falls within JEDEC MO-153

PACKAGING INFORMATION

Orderable Device	Status ⁽¹⁾	Package Type	Package Drawing	Pins	Package Qty	Eco Plan ⁽²⁾	Lead/Ball Finish	MSL Peak Temp ⁽³⁾
TLV5627CD	ACTIVE	SOIC	D	16	40	Green (RoHS & no Sb/Br)	CU NIPDAU	Level-1-260C-UNLIM
TLV5627CDG4	ACTIVE	SOIC	D	16	40	Green (RoHS & no Sb/Br)	CU NIPDAU	Level-1-260C-UNLIM
TLV5627CDR	ACTIVE	SOIC	D	16	2500	Green (RoHS & no Sb/Br)	CU NIPDAU	Level-1-260C-UNLIM
TLV5627CDRG4	ACTIVE	SOIC	D	16	2500	Green (RoHS & no Sb/Br)	CU NIPDAU	Level-1-260C-UNLIM
TLV5627CPW	ACTIVE	TSSOP	PW	16	90	Green (RoHS & no Sb/Br)	CU NIPDAU	Level-1-260C-UNLIM
TLV5627CPWG4	ACTIVE	TSSOP	PW	16	90	Green (RoHS & no Sb/Br)	CU NIPDAU	Level-1-260C-UNLIM
TLV5627CPWR	ACTIVE	TSSOP	PW	16	2000	Green (RoHS & no Sb/Br)	CU NIPDAU	Level-1-260C-UNLIM
TLV5627CPWRG4	ACTIVE	TSSOP	PW	16	2000	Green (RoHS & no Sb/Br)	CU NIPDAU	Level-1-260C-UNLIM
TLV5627ID	ACTIVE	SOIC	D	16	40	Green (RoHS & no Sb/Br)	CU NIPDAU	Level-1-260C-UNLIM
TLV5627IDG4	ACTIVE	SOIC	D	16	40	Green (RoHS & no Sb/Br)	CU NIPDAU	Level-1-260C-UNLIM
TLV5627IPW	ACTIVE	TSSOP	PW	16	90	Green (RoHS & no Sb/Br)	CU NIPDAU	Level-1-260C-UNLIM
TLV5627IPWG4	ACTIVE	TSSOP	PW	16	90	Green (RoHS & no Sb/Br)	CU NIPDAU	Level-1-260C-UNLIM
TLV5627IPWR	ACTIVE	TSSOP	PW	16	2000	Green (RoHS & no Sb/Br)	CU NIPDAU	Level-1-260C-UNLIM
TLV5627IPWRG4	ACTIVE	TSSOP	PW	16	2000	Green (RoHS & no Sb/Br)	CU NIPDAU	Level-1-260C-UNLIM

⁽¹⁾ The marketing status values are defined as follows:

ACTIVE: Product device recommended for new designs.

LIFEBUY: TI has announced that the device will be discontinued, and a lifetime-buy period is in effect.

NRND: Not recommended for new designs. Device is in production to support existing customers, but TI does not recommend using this part in a new design.

PREVIEW: Device has been announced but is not in production. Samples may or may not be available.

OBSELETE: TI has discontinued the production of the device.

⁽²⁾ Eco Plan - The planned eco-friendly classification: Pb-Free (RoHS), Pb-Free (RoHS Exempt), or Green (RoHS & no Sb/Br) - please check <http://www.ti.com/productcontent> for the latest availability information and additional product content details.

TBD: The Pb-Free/Green conversion plan has not been defined.

Pb-Free (RoHS): TI's terms "Lead-Free" or "Pb-Free" mean semiconductor products that are compatible with the current RoHS requirements for all 6 substances, including the requirement that lead not exceed 0.1% by weight in homogeneous materials. Where designed to be soldered at high temperatures, TI Pb-Free products are suitable for use in specified lead-free processes.

Pb-Free (RoHS Exempt): This component has a RoHS exemption for either 1) lead-based flip-chip solder bumps used between the die and package, or 2) lead-based die adhesive used between the die and leadframe. The component is otherwise considered Pb-Free (RoHS compatible) as defined above.

Green (RoHS & no Sb/Br): TI defines "Green" to mean Pb-Free (RoHS compatible), and free of Bromine (Br) and Antimony (Sb) based flame retardants (Br or Sb do not exceed 0.1% by weight in homogeneous material)

⁽³⁾ MSL, Peak Temp. -- The Moisture Sensitivity Level rating according to the JEDEC industry standard classifications, and peak solder temperature.

Important Information and Disclaimer:The information provided on this page represents TI's knowledge and belief as of the date that it is

provided. TI bases its knowledge and belief on information provided by third parties, and makes no representation or warranty as to the accuracy of such information. Efforts are underway to better integrate information from third parties. TI has taken and continues to take reasonable steps to provide representative and accurate information but may not have conducted destructive testing or chemical analysis on incoming materials and chemicals. TI and TI suppliers consider certain information to be proprietary, and thus CAS numbers and other limited information may not be available for release.

In no event shall TI's liability arising out of such information exceed the total purchase price of the TI part(s) at issue in this document sold by TI to Customer on an annual basis.

TAPE AND REEL INFORMATION



QUADRANT ASSIGNMENTS FOR PIN 1 ORIENTATION IN TAPE



*All dimensions are nominal

Device	Package Type	Package Drawing	Pins	SPQ	Reel Diameter (mm)	Reel Width W1 (mm)	A0 (mm)	B0 (mm)	K0 (mm)	P1 (mm)	W (mm)	Pin1 Quadrant
TLV5627CDR	SOIC	D	16	2500	330.0	16.4	6.5	10.3	2.1	8.0	16.0	Q1
TLV5627CPWR	TSSOP	PW	16	2000	330.0	12.4	6.9	5.6	1.6	8.0	12.0	Q1
TLV5627IPWR	TSSOP	PW	16	2000	330.0	12.4	6.9	5.6	1.6	8.0	12.0	Q1

TAPE AND REEL BOX DIMENSIONS

*All dimensions are nominal

Device	Package Type	Package Drawing	Pins	SPQ	Length (mm)	Width (mm)	Height (mm)
TLV5627CDR	SOIC	D	16	2500	346.0	346.0	33.0
TLV5627CPWR	TSSOP	PW	16	2000	346.0	346.0	29.0
TLV5627IPWR	TSSOP	PW	16	2000	346.0	346.0	29.0

IMPORTANT NOTICE

Texas Instruments Incorporated and its subsidiaries (TI) reserve the right to make corrections, modifications, enhancements, improvements, and other changes to its products and services at any time and to discontinue any product or service without notice. Customers should obtain the latest relevant information before placing orders and should verify that such information is current and complete. All products are sold subject to TI's terms and conditions of sale supplied at the time of order acknowledgment.

TI warrants performance of its hardware products to the specifications applicable at the time of sale in accordance with TI's standard warranty. Testing and other quality control techniques are used to the extent TI deems necessary to support this warranty. Except where mandated by government requirements, testing of all parameters of each product is not necessarily performed.

TI assumes no liability for applications assistance or customer product design. Customers are responsible for their products and applications using TI components. To minimize the risks associated with customer products and applications, customers should provide adequate design and operating safeguards.

TI does not warrant or represent that any license, either express or implied, is granted under any TI patent right, copyright, mask work right, or other TI intellectual property right relating to any combination, machine, or process in which TI products or services are used. Information published by TI regarding third-party products or services does not constitute a license from TI to use such products or services or a warranty or endorsement thereof. Use of such information may require a license from a third party under the patents or other intellectual property of the third party, or a license from TI under the patents or other intellectual property of TI.

Reproduction of TI information in TI data books or data sheets is permissible only if reproduction is without alteration and is accompanied by all associated warranties, conditions, limitations, and notices. Reproduction of this information with alteration is an unfair and deceptive business practice. TI is not responsible or liable for such altered documentation. Information of third parties may be subject to additional restrictions.

Resale of TI products or services with statements different from or beyond the parameters stated by TI for that product or service voids all express and any implied warranties for the associated TI product or service and is an unfair and deceptive business practice. TI is not responsible or liable for any such statements.

TI products are not authorized for use in safety-critical applications (such as life support) where a failure of the TI product would reasonably be expected to cause severe personal injury or death, unless officers of the parties have executed an agreement specifically governing such use. Buyers represent that they have all necessary expertise in the safety and regulatory ramifications of their applications, and acknowledge and agree that they are solely responsible for all legal, regulatory and safety-related requirements concerning their products and any use of TI products in such safety-critical applications, notwithstanding any applications-related information or support that may be provided by TI. Further, Buyers must fully indemnify TI and its representatives against any damages arising out of the use of TI products in such safety-critical applications.

TI products are neither designed nor intended for use in military/aerospace applications or environments unless the TI products are specifically designated by TI as military-grade or "enhanced plastic." Only products designated by TI as military-grade meet military specifications. Buyers acknowledge and agree that any such use of TI products which TI has not designated as military-grade is solely at the Buyer's risk, and that they are solely responsible for compliance with all legal and regulatory requirements in connection with such use.

TI products are neither designed nor intended for use in automotive applications or environments unless the specific TI products are designated by TI as compliant with ISO/TS 16949 requirements. Buyers acknowledge and agree that, if they use any non-designated products in automotive applications, TI will not be responsible for any failure to meet such requirements.

Following are URLs where you can obtain information on other Texas Instruments products and application solutions:

Products

Amplifiers	amplifier.ti.com
Data Converters	dataconverter.ti.com
DLP® Products	www.dlp.com
DSP	dsp.ti.com
Clocks and Timers	www.ti.com/clocks
Interface	interface.ti.com
Logic	logic.ti.com
Power Mgmt	power.ti.com
Microcontrollers	microcontroller.ti.com
RFID	www.ti-rfid.com
RF/IF and ZigBee® Solutions	www.ti.com/lprf

Applications

Audio	www.ti.com/audio
Automotive	www.ti.com/automotive
Broadband	www.ti.com/broadband
Digital Control	www.ti.com/digitalcontrol
Medical	www.ti.com/medical
Military	www.ti.com/military
Optical Networking	www.ti.com/opticalnetwork
Security	www.ti.com/security
Telephony	www.ti.com/telephony
Video & Imaging	www.ti.com/video
Wireless	www.ti.com/wireless

Mailing Address: Texas Instruments, Post Office Box 655303, Dallas, Texas 75265
Copyright © 2009, Texas Instruments Incorporated