



## IS180

### DESCRIPTION

The IS180 series of optically coupled isolator consist of two infrared light emitting diodes in reverse parallel connection and optically coupled to an NPN silicon photo transistor in a space efficient Mini Flat Package.

### FEATURES

- AC Isolation Voltage 3750V<sub>RMS</sub>
- Wide Operating Temperature Range -55°C to +100°C
- Lead Free and RoHS Compliant
- UL File E91231 Package Code "FPA"

### APPLICATIONS

- Computer Terminals
- Industrial System Controllers
- Measuring Instruments
- System Appliances

### ORDER INFORMATION

- Available in Tape and Reel with 3000pcs per reel

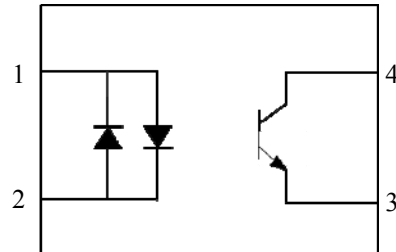

### ABSOLUTE MAXIMUM RATINGS

#### Input Diode

Forward Current	±50mA
Reverse Voltage	6V
Power dissipation	70mW

#### Output Transistor

Collector to Emitter Voltage $BV_{CEO}$	35V
Emitter to Collector Voltage $BV_{ECO}$	6V
Collector Current	50mA
Power Dissipation	150mW

#### Total Package

Operating Temperature	-55 to +100 °C
Storage Temperature	-55 to +150 °C
Total Power Dissipation	170mW
Lead Soldering Temperature (for 10s)	260°C

#### ISOCOM COMPONENTS 2004 LTD

Unit 25B, Park View Road West, Park View Industrial Estate  
Hartlepool, Cleveland, TS25 1UD, United Kingdom  
Tel: +44 (0)1429 863 609 Fax : +44 (0)1429 863 581  
e-mail: sales@isocom.co.uk  
<http://www.isocom.com>

#### ISOCOM COMPONENTS ASIA LTD

Hong Kong Office,  
Block A, 8/F, Wah Hing Industrial mansion,  
36 Tai Yau Street, San Po Kong, Kowloon, Hong Kong.  
Tel: +852 2995 9217 Fax : +852 8161 6292  
e-mail sales@isocom.com.hk



## IS180

### ELECTRICAL CHARACTERISTICS (Ambient Temperature = 25°C unless otherwise specified)

#### INPUT

Parameter	Symbol	Test Condition	Min	Typ.	Max	Unit
Forward Voltage	$V_F$	$I_F = \pm 20\text{mA}$		1.2	1.4	V
Terminal Capacitance	$C_t$	$V = 0\text{V}, f = 1\text{KHz}$		30	250	pF

#### OUTPUT

Parameter	Symbol	Test Condition	Min	Typ.	Max	Unit
Collector—Emitter breakdown Voltage	$BV_{CEO}$	$I_C = 0.1\text{mA}, I_F = 0\text{mA}$	35			V
Emitter—Collector breakdown Voltage	$BV_{ECO}$	$I_E = 10\mu\text{A}, I_F = 0\text{mA}$	6			V
Collector-Emitter Dark Current	$I_{CEO}$	$V_{CE} = 20\text{V}, I_F = 0\text{mA}$			100	nA

#### COUPLED

Parameter	Symbol	Test Condition	Min	Typ.	Max	Unit
Current Transfer Ratio	CTR	$I_F = \pm 1\text{mA}, V_{CE} = 5\text{V}$	20		400	%
		Optional CTR Grades A	50		150	
Collector—Emitter Saturation Voltage	$V_{CE(sat)}$	$I_F = \pm 20\text{mA}, I_C = 1\text{mA}$			0.2	V
Input to Output Isolation Voltage	$V_{ISO}$	Note 1	3750			$V_{RMS}$
Input to Output Isolation Resistance	$R_{ISO}$	$V_{IO} = 500\text{V}$ Note 1	$5 \times 10^{10}$			$\Omega$
Floating Capacitance	$C_f$	$V = 0\text{V}, f = 1\text{MHz}$		0.5	1	pF
Output Rise Time	$t_r$	$V_{CE} = 2\text{V}, I_C = 2\text{mA}, R_L = 100\Omega$		4	18	$\mu\text{s}$
Output Fall Time	$t_f$			3	18	$\mu\text{s}$

Note 1 : Measure with input leads shorted together and output leads shorted together.

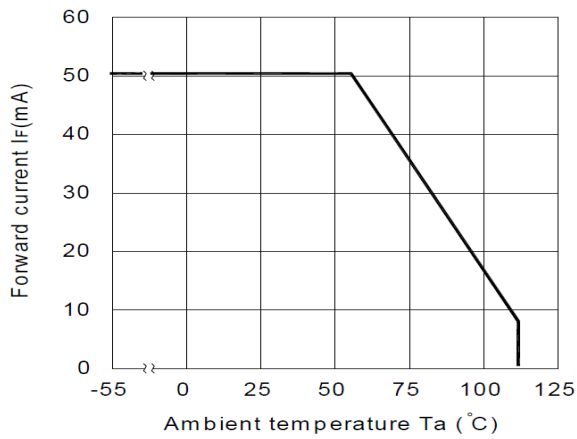

**Fig 1 Forward Current vs  $T_A$**

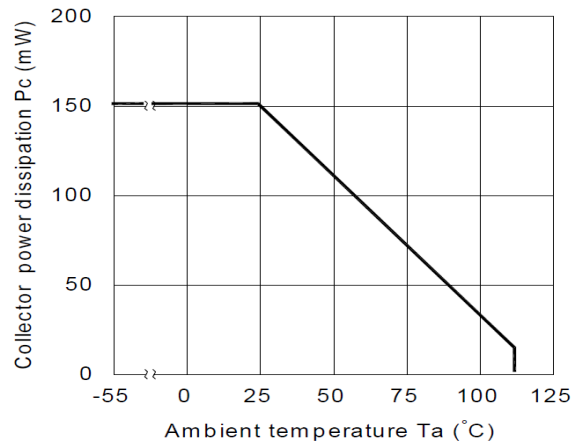

**Fig 2 Collector Power Dissipation vs  $T_A$**

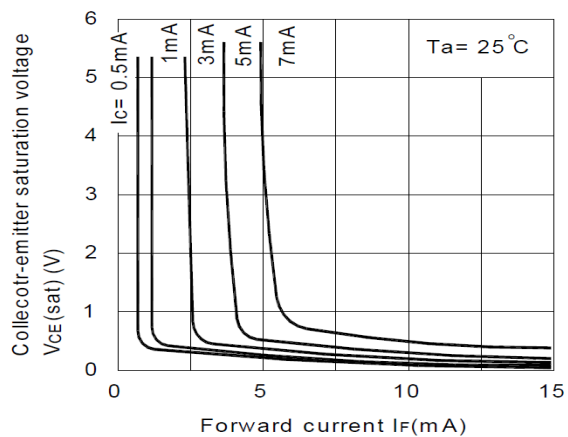

**Fig 3 Collector-emitter Saturation Voltage vs Forward Current**

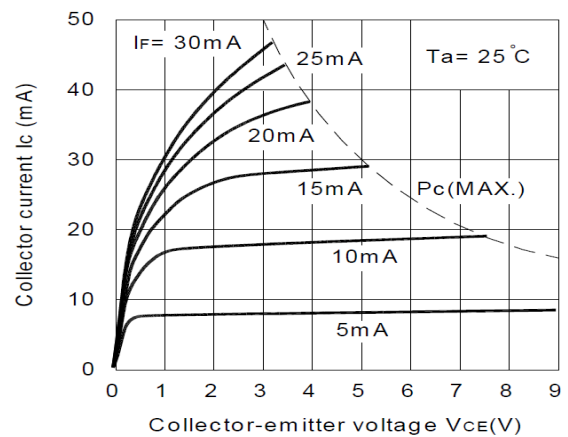

**Fig 4 Collector Current vs Collector-emitter Voltage**

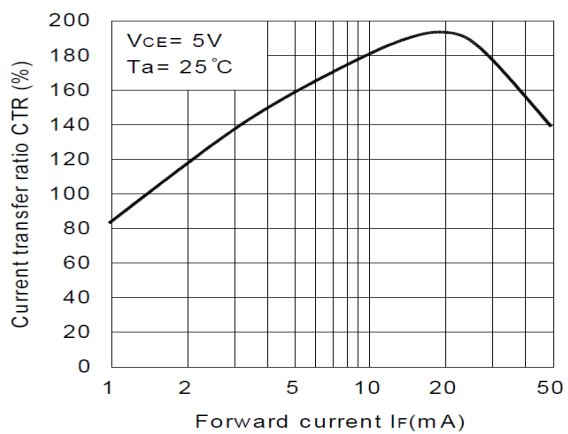

**Fig 5 Current Transfer Ratio vs Forward Current**

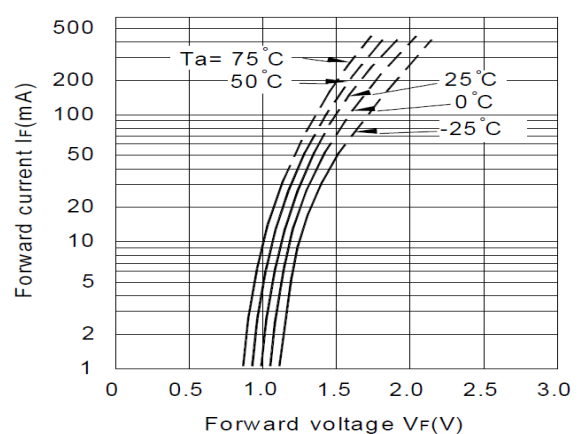

**Fig 6 Forward Current vs Forward Voltage**



# IS180

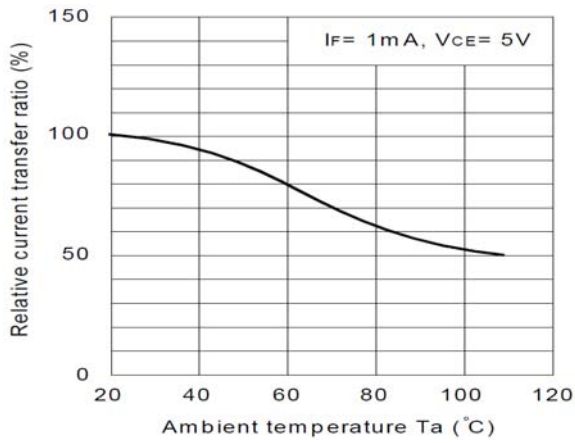

**Fig 7 Relative CTR vs TA**

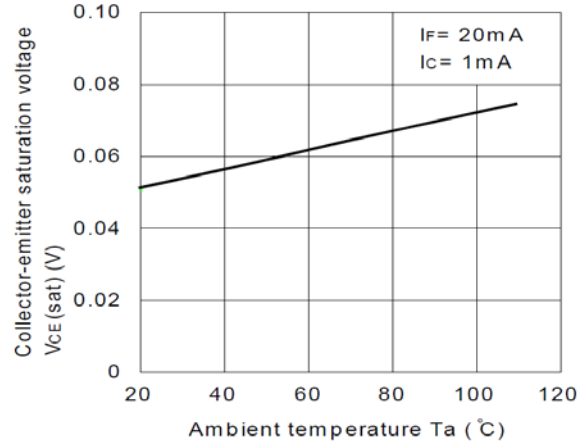

**Fig 8 Collector-emitter Saturation Voltage vs TA**

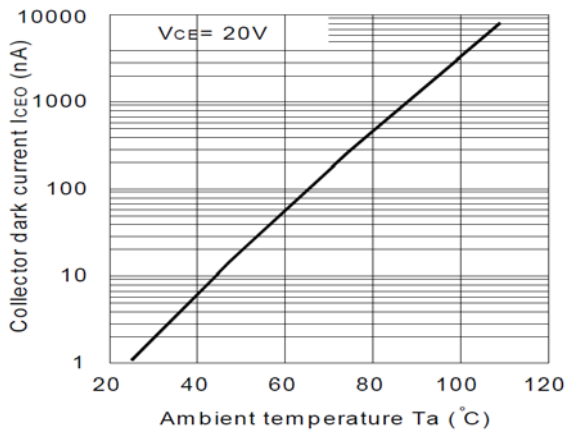

**Fig 9 Collector Dark Current vs TA**

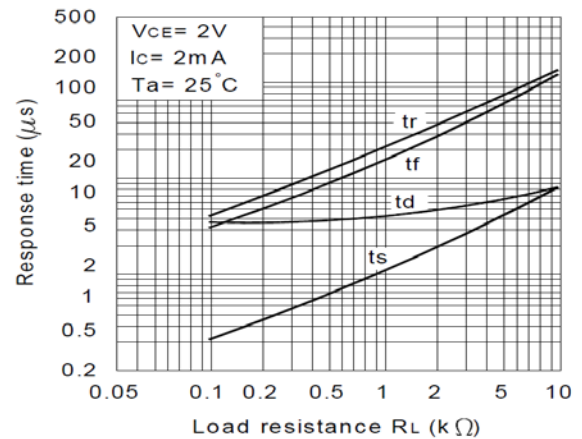

**Fig 10 Response Time vs Load Resistance**

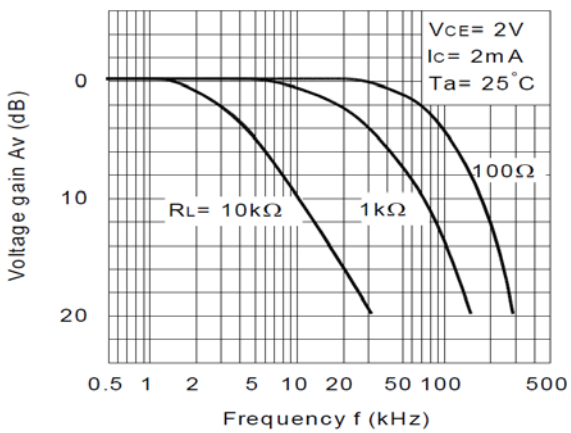

**Fig 11 Frequency Response**

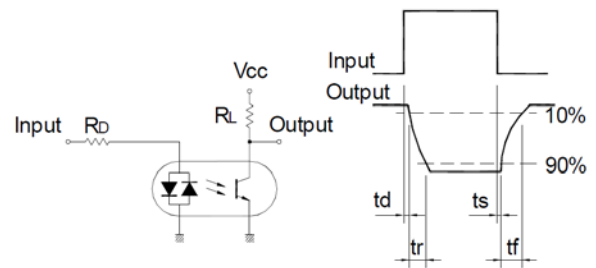

**Response Time Test Circuit**



## IS180

### STANDARD PACKING QUANTITY

IS180			
After PN	PN	Description	Packing quantity
None	IS180, IS180A	Surface Mount Tape & Reel	3000 pcs per reel

### DEVICE MARKING

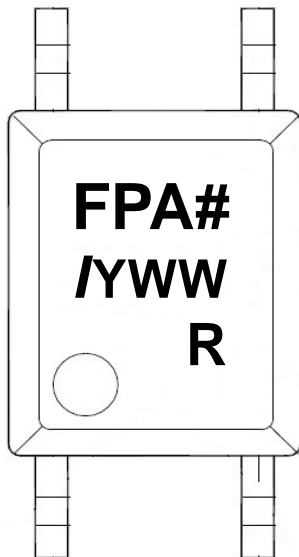

**FPA#** denotes Device Part Number where “#” is internal control number  
**I** denotes Isocom  
**Y** denotes 1 digit Year code  
**WW** denotes 2 digit Week code  
**R** denotes CTR Grade



## IS180

### PACKAGE DIMENSIONS (mm)

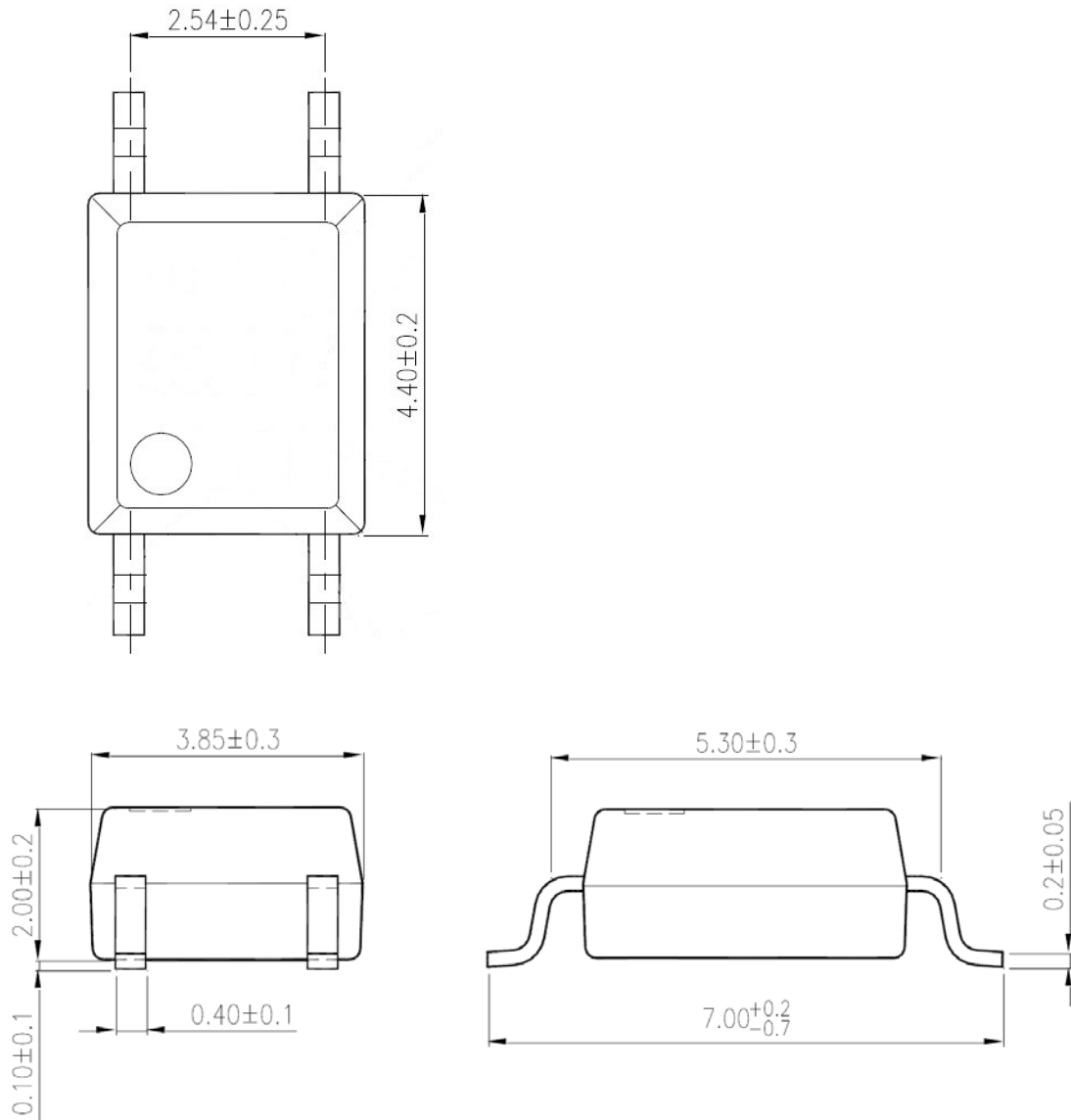



**IS180**

**RECOMMENDED SOLDER PAD LAYOUT (mm)**

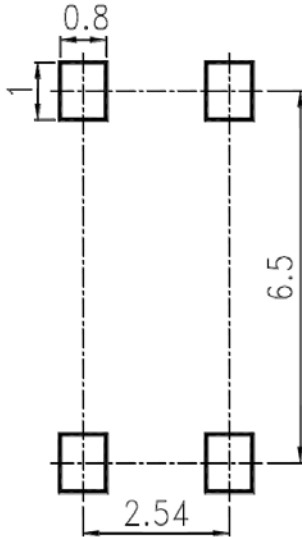

**TAPE AND REEL PACKAGING**

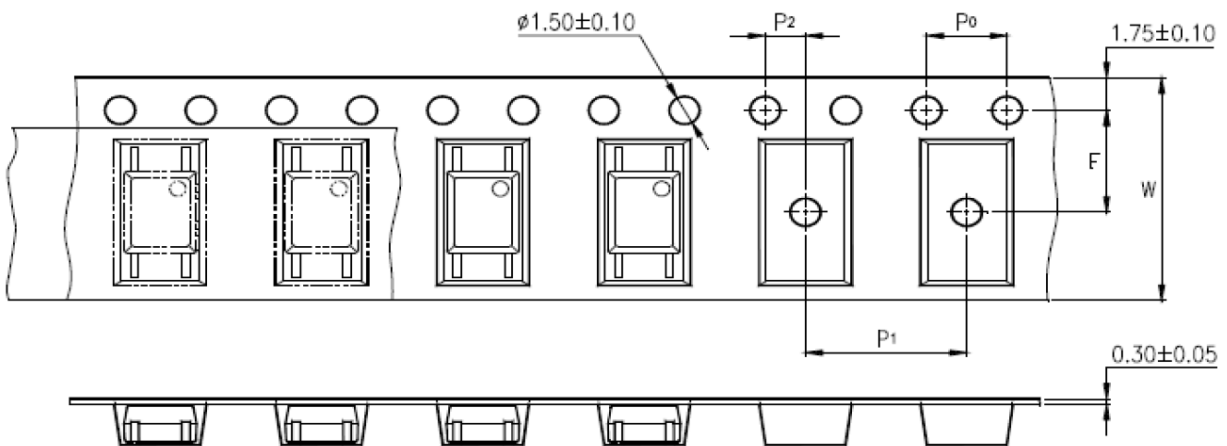

Description	Symbol	Dimensions in mm ( inches )
Tape wide	W	$12 \pm 0.3$ ( .47 )
Pitch of sprocket holes	$P_0$	$4 \pm 0.1$ ( .15 )
Distance of compartment	F	$5.5 \pm 0.1$ ( .217 )
	$P_2$	$2 \pm 0.1$ ( .079 )
Distance of compartment to compartment	$P_1$	$8 \pm 0.1$ ( .315 )



**IS180**

**IR REFLOW SOLDERING TEMPERATURE PROFILE**  
(One Time Reflow Soldering is Recommended)

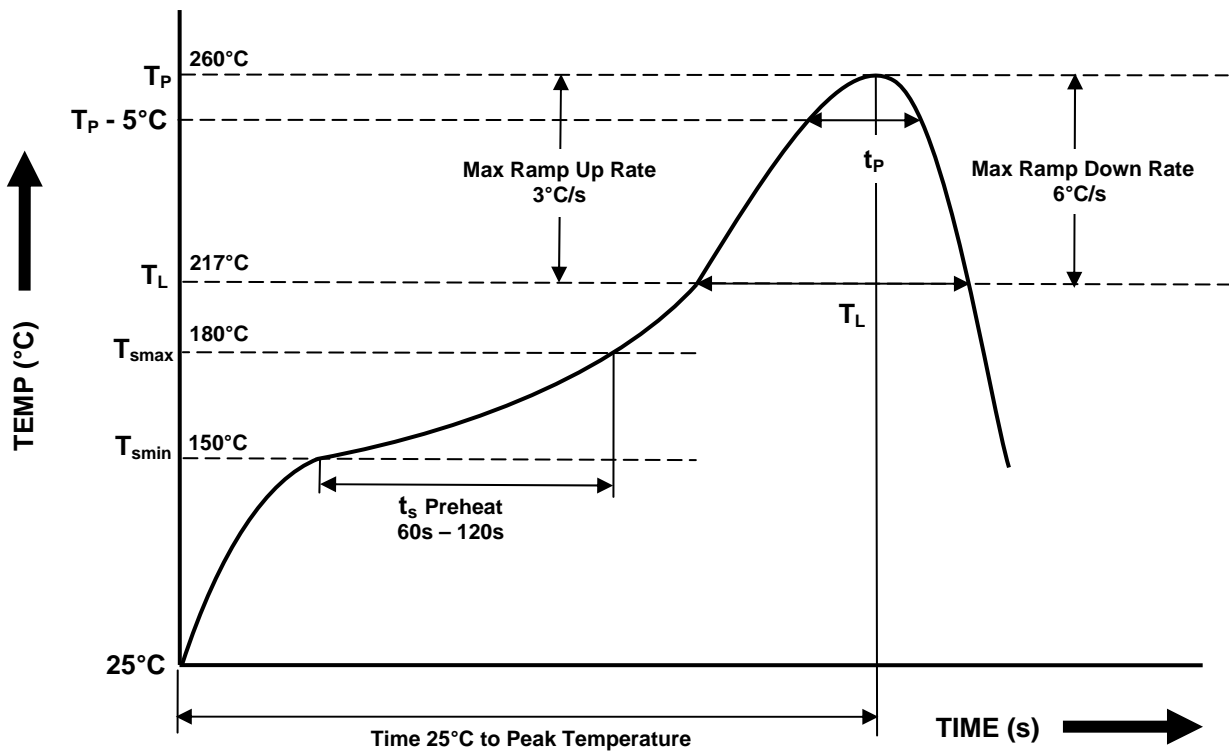

Profile Details	Conditions
<b>Preheat</b> - Min Temperature ( $T_{SMIN}$ ) - Max Temperature ( $T_{SMAX}$ ) - Time $T_{SMIN}$ to $T_{SMAX}$ ( $t_s$ )	150°C 180°C 60s - 120s
<b>Soldering Zone</b> - Peak Temperature ( $T_P$ ) - Liquidous Temperature ( $T_L$ ) - Time within 5°C of Actual Peak Temperature ( $T_P - 5^\circ C$ ) - Time maintained above $T_L$ ( $t_L$ ) - Ramp Up Rate ( $T_L$ to $T_P$ ) - Ramp Down Rate ( $T_P$ to $T_L$ )	260°C 217°C 20s 60s 3°C/s max 3 - 6°C/s
Average Ramp Up Rate ( $T_{smax}$ to $T_P$ )	3°C/s max
Time 25°C to Peak Temperature	8 minutes max





**NOTES :**

- Isocom is continually improving the quality, reliability, function or design and Isocom reserves the right to make changes without further notices.
- The products shown in this publication are designed for the general use in electronic applications such as office automation equipment, communications devices, audio/visual equipment, electrical application and instrumentation.
- For equipment/application where high reliability or safety is required, such as space applications, nuclear power control equipment, medical equipment, etc., please contact our sales representatives.
- When requiring a device for any "specific" application, please contact our sales for advice.
- The contents described herein are subject to change without prior notice.
- Do not immerse device body in solder paste.



## Disclaimer

ISOCOM is continually working to improve the quality and reliability of its products. Nevertheless, semiconductor devices in general can malfunction or fail due to their inherent electrical sensitivity and vulnerability to physical stress. It is the responsibility of the buyer, when utilizing ISOCOM products, to comply with the standards of safety in making a safe design for the entire system, and to avoid situations in which a malfunction or failure of such ISOCOM products could cause loss of human life, bodily injury or damage to property.

In developing your designs, please ensure that ISOCOM products are used within specified operating ranges as set forth in the most recent ISOCOM products specifications.

\_\_ The ISOCOM products listed in this document are intended for usage in general electronics applications (computer, personal equipment, office equipment, measuring equipment, industrial robotics, domestic appliances, etc.). These ISOCOM products are neither intended nor warranted for usage in equipment that requires extraordinarily high quality and/or reliability or a malfunction or failure of which may cause loss of human life or bodily injury ("Unintended Usage"). Unintended Usage include atomic energy control instruments, airplane or spaceship instruments, transportation Instruments, traffic signal instruments, combustion control instruments, medical Instruments, all types of safety devices, etc.. Unintended Usage of ISOCOM products listed in this document shall be made at the customer's own risk.

\_\_ Gallium arsenide (GaAs) is a substance used in the products described in this document. GaAs dust and fumes are toxic. Do not break, cut or pulverize the product, or use chemicals to dissolve them. When disposing of the products, follow the appropriate regulations. Do not dispose of the products with other industrial waste or with domestic garbage.

\_\_ The products described in this document are subject to the foreign exchange and foreign trade laws.

\_\_ The information contained herein is presented only as a guide for the applications of our products. No responsibility is assumed by ISOCOM Components for any infringements of intellectual property or other rights of the third parties which may result from its use. No license is granted by implication or otherwise under any intellectual property or other rights of ISOCOM Components or others.

\_\_ The information contained herein is subject to change without notice.