

TLE8458

LIN Transceiver with integrated Voltage Regulator

TLE8458G
TLE8458GV33

Data Sheet

Rev. 1.1, 2014-04-01

1	Overview	3
2	Block Diagram	4
3	Pin Configuration	5
3.1	Pin Assignments	5
3.2	Pin Definitions and Functions	5
4	General Product Characteristics	6
4.1	Absolute Maximum Ratings	6
4.2	Functional Range	7
4.3	Thermal Characteristics	7
5	Mode Control	8
5.1	Operation Mode State Diagram	8
5.2	Description of Mode Control	9
5.2.1	Stand-By Mode	11
5.2.2	Normal Operation Mode	11
5.2.2.1	Normal Slope Mode	12
5.2.2.2	Software Flash Mode	12
5.2.3	Stop Mode	13
5.2.4	Sleep Mode	13
5.2.5	Wake-up Events in Sleep and Stop Mode	13
5.2.5.1	Bus Wake-up Event	14
5.2.5.2	Local Wake-up Event	14
5.2.5.3	Mode Transition via EN pin	15
5.2.6	Power Up	16
5.2.7	Over-Temperature Protection	16
5.3	Current Consumption	17
5.4	Electrical Characteristics EN and WK Pins	18
5.5	Power Up, Power Down	18
6	Voltage Regulator	19
6.1	Description of Voltage Regulator	19
6.2	Electrical Characteristics of the Voltage Regulator	19
7	LIN Transceiver	20
7.1	Functional Description	20
7.1.1	Undervoltage Detection	21
7.1.2	TxD Time-Out	22
7.1.3	LIN Specifications	22
7.2	Electrical Characteristics of the LIN Transceiver	23
8	Application Information	27
8.1	ESD Tests	28
8.1.1	EMC Measurement	28
8.2	Pin Compatibility to Stand-Alone LIN transceivers	28
9	Package Outlines	29
10	Revision History	30



1 Overview

Features

- LIN Transceiver compliant to LIN 2.1
- 5 V or 3.3 V Low Drop Voltage Regulator
- 50 mA output current capability
- Normal, Stop, and Sleep modes
- Wake-up via bus from Sleep Mode
- Wake-up from Local WK pin
- Very low quiescent current in Stop Mode
- Very low quiescent current in Sleep Mode
- Very high ESD Robustness ± 10 kV according IEC61000-4-2
- Bus short to ground and V_{Bat} protection
- Software Flash mode
- Over-Temperature protection
- Pin- and function compatible to single LIN Transceivers, like TLE7259-3GE
- Green (RoHS compliant) product
- AEC Qualified

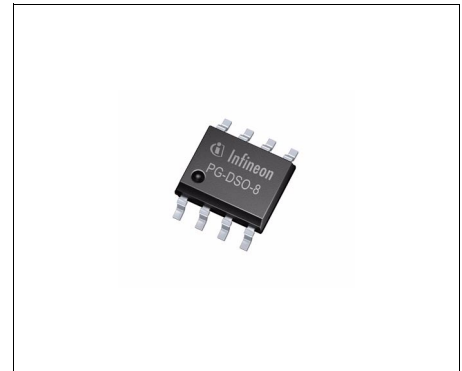

PG-DSO-8-16

Description

The TLE8458G and TLE8458GV33 integrate a low drop voltage regulator and a LIN transceiver on one monolithic circuit. The device is suitable to supply microcontrollers and driving a LIN bus at the same time. The TLE8458 is pin compatible to stand-alone LIN transceivers like the TLE7259-3GE. The combination of a voltage regulator and a LIN transceiver on one circuit decreases the quiescent current for a typical application to a value of 8 μA , while the TLE8458 is still able to wake-up off a LIN bus signal or a signal change on the local wake-up input WK. Compliant to all LIN standards and with a wide operational supply range, the TLE8458 can be used in all automotive applications.

Based on the Infineon Smart Power Technology SPT[®], the TLE8458 provides excellent ESD robustness together with a very high electro-magnetic immunity (EMI). The TLE8458 reaches a very low level of electro-magnetic emission (EME) within a broad frequency range. The TLE8458 family and the Infineon SPT[®] technology are AEC qualified and tailored to withstand the harsh conditions in the automotive environment.

Type	Package	Marking	Note
TLE8458G	PG-DSO-8-16	8458G	$V_{\text{CC}} = 5 \text{ V}$
TLE8458GV33	PG-DSO-8-16	8458GV3	$V_{\text{CC}} = 3.3 \text{ V}$

2 Block Diagram

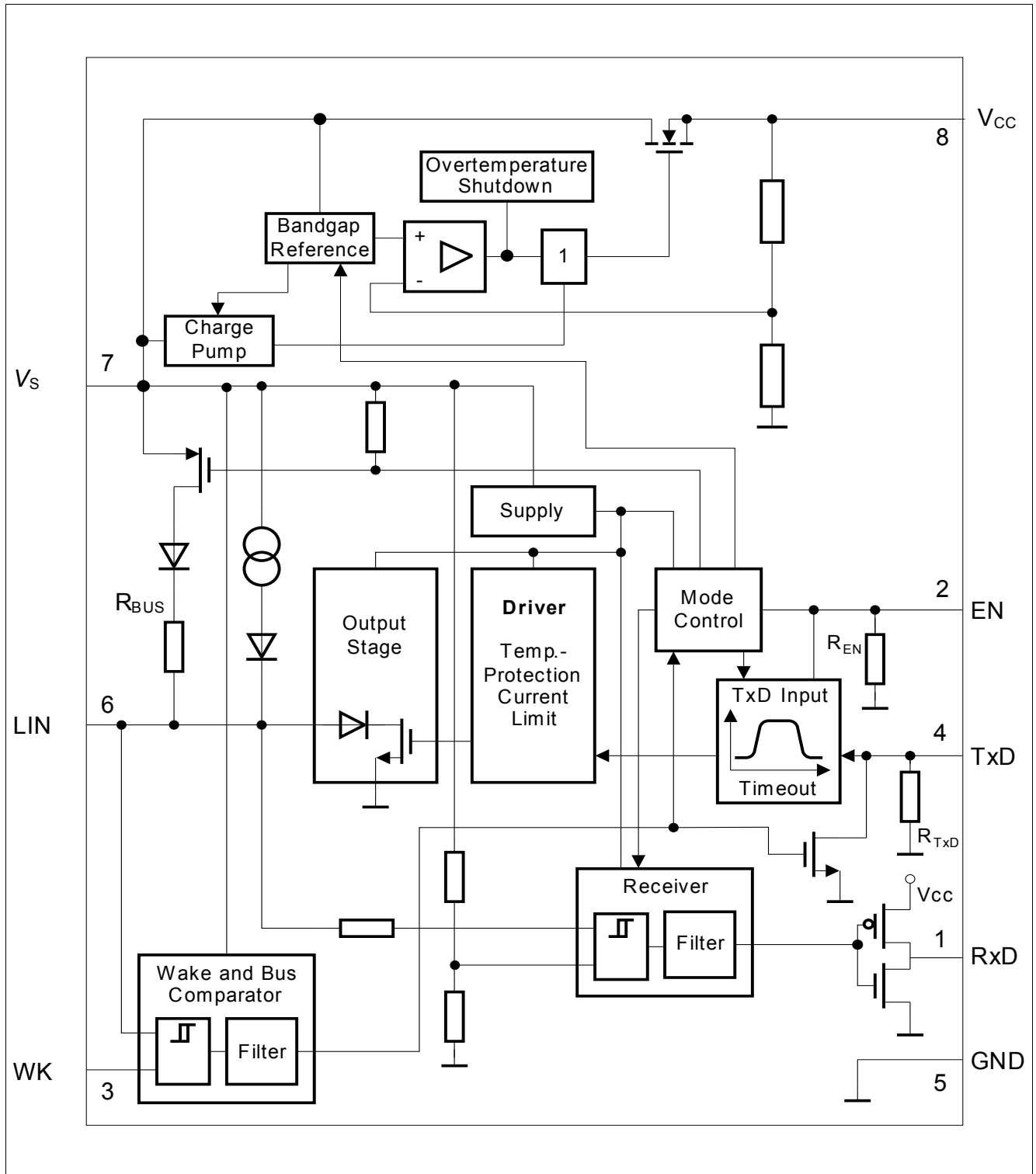

Figure 1 Block Diagram

3 Pin Configuration

3.1 Pin Assignments

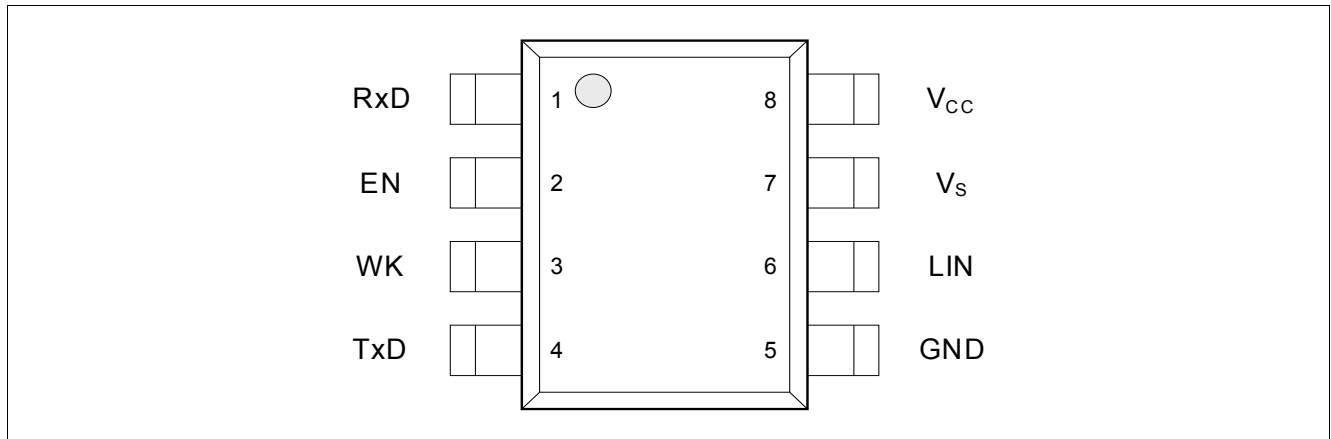

Figure 2 Pin Configuration

3.2 Pin Definitions and Functions

Table 1 Pin Definition

Pin	Symbol	Function
1	RxD	Receive Data Output; Low in dominant state, active low after a Wake-up event on BUS or WK pin.
2	EN	Enable Input; Integrated pull-down resistor, device set to normal operation mode when HIGH.
3	WK	Wake-up Input; Active LOW, negative edge triggered, internal pull-up.
4	TxD	Transmit Data Input; Integrated pull-down resistor, LOW in dominant state. Active LOW after Wake-up via WK pin.
5	GND	Ground
6	LIN	Bus Output / Input; LIN bus input / Output, LOW in dominant state, Internal termination and pull-up current source.
7	V_S	Battery Supply Input
8	V_{CC}	Output Voltage; Decouple to GND with a capacitor $C_{V_{CC}} \geq 470 \text{ nF}$, $ESR < 6 \Omega$ at 10 kHz, Active during Normal Mode, disabled in Sleep Mode.

4 General Product Characteristics

4.1 Absolute Maximum Ratings

Table 2 Absolute Maximum Ratings ¹⁾

All voltages with respect to ground, positive current flowing into pin (unless otherwise specified)

Parameter	Symbol	Values			Unit	Note / Test Condition	Number
		Min.	Typ.	Max.			
Voltages							
Supply Voltage on V_S pin	V_S	-0.3	–	40	V	LIN2.1 Param 11	P_4.1.1
Input Voltage on LIN, WK pin versus GND	$V_{LIN,G}$	-40	–	40	V	–	P_4.1.2
Logic Voltages at EN, TxD, RxD pin	$V_{L,max}$	-0.3	–	5.5	V	–	P_4.1.3
Output Voltage at V_{CC} pin	V_{CC}	-0.3	–	5.5	V	Static	P_4.1.4
Temperatures							
Junction Temperature	T_j	-40	–	150	°C	–	P_4.1.5
Storage Temperature	T_{stg}	-55	–	150	°C	–	P_4.1.6
ESD Resistivity							
ESD all pins	$V_{ESD,HBM}$	-2	–	2	kV	HBM ²⁾	P_4.1.7
ESD V_S , WK, LIN versus GND	$V_{ESD,HBM}$	-8	–	8	kV	HBM ²⁾	P_4.1.8
ESD Resistivity all pins versus GND	$V_{ESD,CDM}$	-750	–	750	V	CDM ³⁾	P_4.1.9

1) Not subject to production test; specified by design.

2) ESD susceptibility, HBM according to ANSI/ESDA/JEDEC JS-001 (1.5 kΩ, 100pF)

3) ESD susceptibility, Charged Device Model "CDM" EIA / JESD 22-C101 or ESDA STM5.3.1

Notes

1. Stresses above the ones listed here may cause permanent damage to the device. Exposure to absolute maximum rating conditions for extended periods may affect device reliability.
2. Integrated protection functions are designed to prevent IC destruction under fault conditions described in the data sheet. Fault conditions are considered as "outside" normal operating range. Protection functions are not designed for continuous repetitive operation.

4.2 Functional Range

Table 3 Functional Range

Parameter	Symbol	Values			Unit	Note / Test Condition	Number
		Min.	Typ.	Max.			
Extended Supply Range	$V_{S(EXT)}$	5.5	–	40	V	Parameter deviations possible	P_4.2.1
Supply Voltage for Normal Operation	$V_{S(Nor)}$	7	–	27	V	LIN 2.1 Param. 11	P_4.2.3
Junction Temperature	T_j	-40	–	150	°C	–	P_4.2.2

Note: Within the functional range, the IC operates as described in the circuit description. The electrical characteristics are specified within the conditions given in the related electrical characteristics table.

4.3 Thermal Characteristics

Table 4 Thermal Resistance

Parameter	Symbol	Values			Unit	Note / Test Condition	Number
		Min.	Typ.	Max.			
Thermal Resistance							
Junction to Case PG-DSO-8-16	$R_{thJC,G}$	–	55	–	K/W	¹⁾	P_4.3.1
Junction to Ambient PG-DSO-8-16	$R_{thJA,G}$	–	120	–	K/W	^{1), 2)}	P_4.3.2
Thermal Shutdown Junction Temperature							
V_{CC} Shutdown Temperature	$T_{SD,VCC}$	150	–	200	°C	³⁾	P_4.3.5
V_{CC} Thermal Shutdown Hysteresis	$\Delta T_{SD,VCC}$	–	35	–	K	³⁾	P_4.3.6
LIN Shutdown Temperature	$T_{SD,LIN}$	150	–	200	°C	³⁾	P_4.3.7
LIN Thermal Shutdown Hysteresis	$\Delta T_{SD,LIN}$	–	10	–	K	³⁾	P_4.3.8

1) Not subject to production test. Simulated thermal resistance

2) The R_{thJA} values are according to Jedec JESD51-2,-7 at natural convection on 2s2p board for 1 W. Package was simulated on a 76.2 × 114.3 × 1.5 mm³ board with 2 inner copper layers (70 μm thick).

3) Not subject to production test, specified by design.

5 Mode Control

5.1 Operation Mode State Diagram

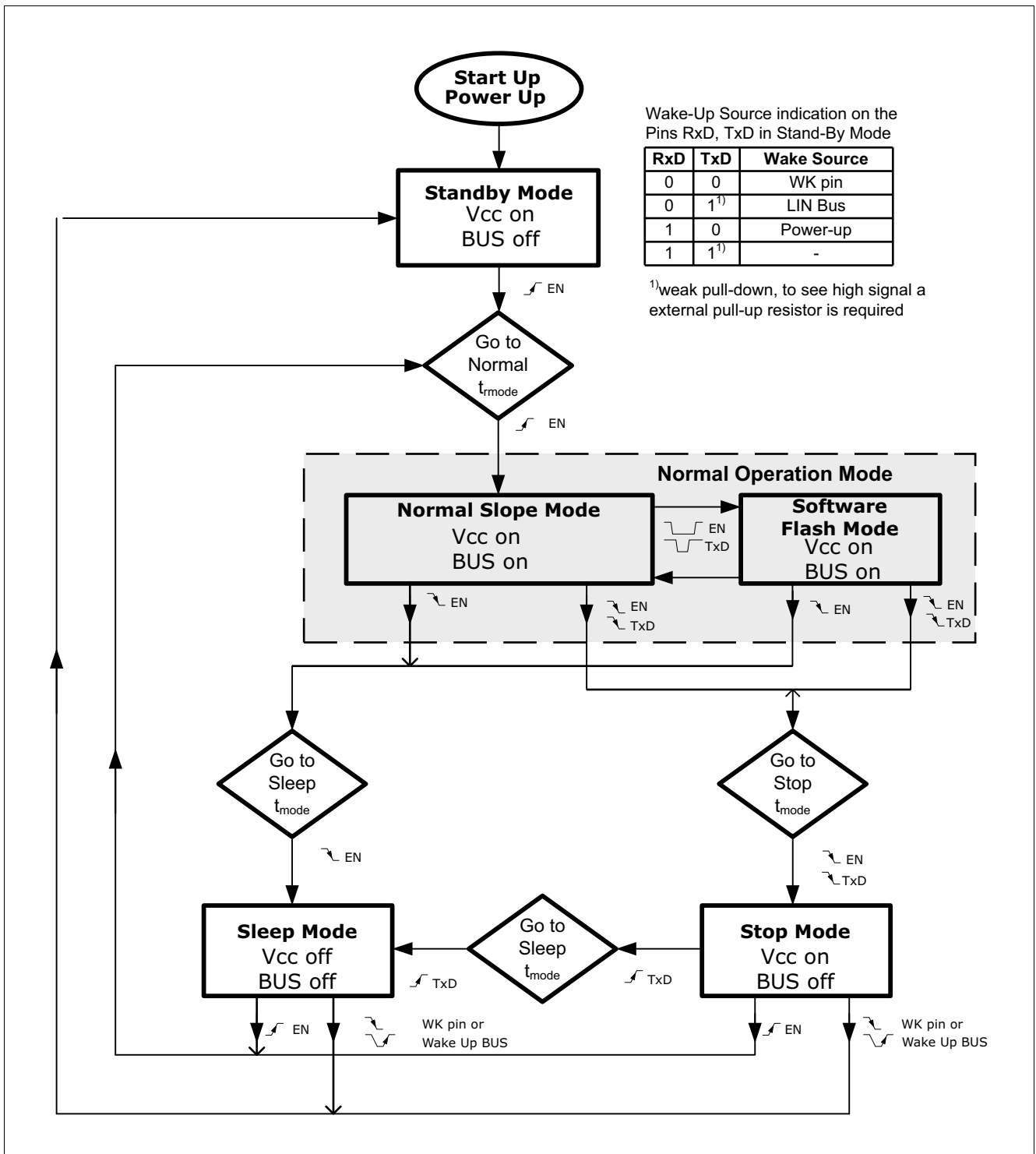

Figure 3 Operation Mode State Diagram

5.2 Description of Mode Control

The TLE8458 has 4 major operation modes:

- Normal Operation Mode
- Stand-By Mode
- Sleep Mode
- Stop Mode

The Normal Operation mode contains 2 sub-operation modes, which differentiate by the slew rate control of the LIN Bus signal (see [Figure 3](#)).

Sub-operation modes with different slew rates on the BUS pin:

- Normal Slope Mode, for data transmission rates up to 20 kBaud
- Software Flash mode, for programming of the external microcontroller

The operation mode of the TLE8458 is selected by the EN pin and the TxD pin. (see [Table 5](#), see [Figure 4](#)).

Table 5 Operation Modes

Mode	EN	TxD	RxD	V _{CC}	LIN Bus Termination	Comments
Normal Operation Mode	HIGH	LOW HIGH ¹⁾	LOW HIGH	ON	30 kΩ (typical)	TxD drives the data to the bus, RxD indicates the data on the bus.
Stand-By Mode	LOW	LOW HIGH ²⁾	LOW HIGH	ON	30 kΩ (typical)	In Stand-By Mode the RxD and TxD pins indicate the Wake-up source
Sleep Mode	LOW	HIGH	Float	OFF	High Impedance	For Sleep Mode TxD needs to be HIGH for the time t_{mode1}
Stop Mode	LOW	LOW	Float	ON	High Impedance	For Stop Mode TxD needs to be LOW for the time t_{mode1}

1) The TxD pin acts as an input

2) The TxD pin acts as an output and indicates the Wake-up source. The TxD input needs an external termination to indicate a HIGH or a LOW signal. The external termination could be a pull-up resistor or an active microcontroller output.

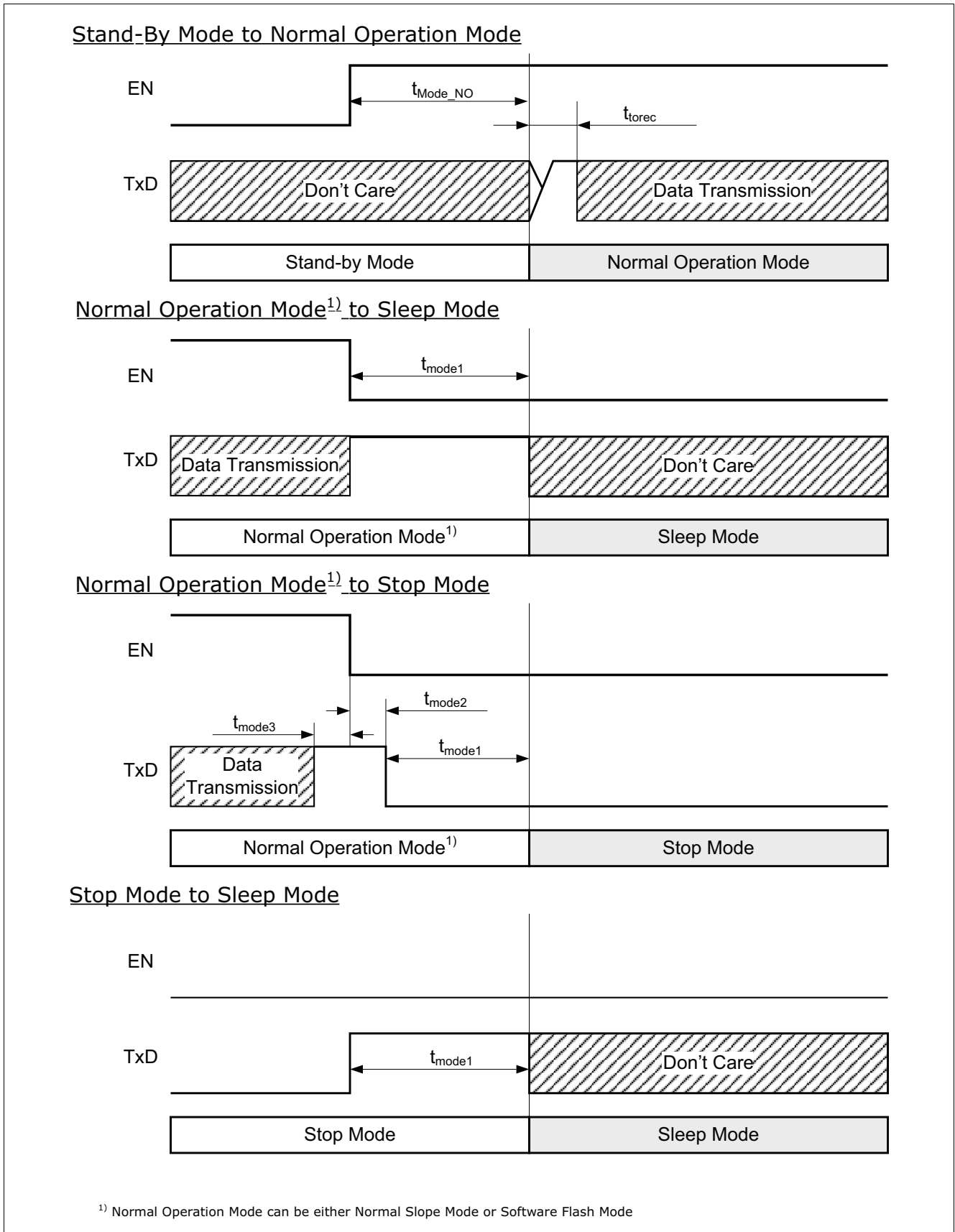

Figure 4 Mode Transition

5.2.1 Stand-By Mode

The Stand-By Mode is an idle operation mode, which disables the communication to the LIN bus. The TLE8458 enters automatically the Stand-By Mode after a Power-up. By setting the EN pin to HIGH, the operation mode changes to Normal Operation Mode, regardless of the signal applied to the TxD pin.

The TLE8458 can be transferred to Stand-By mode by the following options:

- After Power-up on the supply V_S , the TLE8458 starts in Stand-By Mode.
- From Sleep Mode or from Stop Mode the TLE8458 changes to Stand-By Mode if a Wake-up event occurs on the LIN bus.
- From Sleep Mode or from Stop Mode the TLE8458 changes to Stand-By Mode if a Wake-up event occurs on the local Wake input WK.
- In case of an undervoltage event on V_S , the TLE8458 changes to Stand-By Mode regardless of selected operation mode.

In Stand-By mode the external power supply V_{CC} is active and LIN bus output stage is disabled. The TLE8458 provides the following functionality in Stand-By Mode:

- The power supply V_{CC} is active and functional.
- The LIN transceiver output stage is disabled, no communication to the LIN bus is possible.
- The LIN transceiver bus input receiver is disabled.
- The LIN bus is terminated by the 30 k Ω .
- Both digital pins, the TxD pin and the RxD pin act as output pins and indicate a Wake-up or a Power-up event²⁾.
- The EN input pin is active. By setting the EN pin to HIGH the TLE8458 changes the operation mode to Normal Operation Mode (see [Figure 3](#)).
- The Wake-up logic is disabled. Wake-up events don't trigger an operation mode change.

Table 6 Logic table for Wake-up monitoring¹⁾

Power-up	Wake-up event	RxD	TxD ²⁾	Comments
Yes	No	HIGH	LOW	Power Up event
No	Via LIN Bus	LOW	HIGH	Wake-up via LIN Bus
No	Via WK Pin	LOW	LOW	Wake-up via local Wake pin WK

1) The Wake-up monitor is only active in Stand-By Mode

2) The TxD input needs an external termination to indicate a "High" or a "Low" signal. The external termination could be a pull-up resistor or an active microcontroller output.

5.2.2 Normal Operation Mode

The TLE8458 enters the Normal Operation Mode after the microcontroller sets EN to "High" (see [Figure 4](#)). In Normal Operation mode the LIN bus receiver and the LIN bus transmitter are active. The TLE8458 converts the logical HIGH and LOW signals on the TxD input pin to DOMINANT and RECESSIVE signals to the LIN bus. Simultaneously the input receiver of the TLE8458 converts the DOMINANT and RECESSIVE signals on the LIN bus to HIGH and LOW signals to the RxD output. In Normal Operation mode the output voltage V_{CC} is active and the bus termination is set to 30 k Ω .

Normal Slope Mode and the Software Flash Mode are Normal Operation Modes. In these two sub-modes the behavior of the power supply V_{CC} and the bus termination are the same. Per default the TLE8458 always enters into Normal Slope Mode, either from Sleep Mode, Stop Mode or from Stand-By Mode. The Software Flash Mode can only be entered from Normal Slope mode.

In order to avoid any bus disturbance during a mode change, the output stage of the TLE8458 is disabled and set to recessive state during the mode change procedure. To release the TLE8458 for data communication on the LIN bus, the TxD pin needs to be set to HIGH for the time $t_{\text{to rec}}$ after the operation mode change.

5.2.2.1 Normal Slope Mode

In Normal Slope Mode the maximum data transmission rate of the LIN transceiver is limited by the slope control mechanism of LIN output signal. The limitation of the slew rate of the LIN output signal results in an optimized radiated emission fulfilling automotive EMC requirements.

The data transmission rate of the TLE8458G and the TLE8458GV33 is limited to 20 kBaud in Normal Operation Mode and the devices are compliant to the specification LIN2.1.

5.2.2.2 Software Flash Mode

Software Flash Mode is a Normal Operation Mode and it is possible to transmit data to the LIN bus and receive data from the LIN bus. The slope control mechanism of the LIN transmitter output stage is disabled and therefore it is possible to reach higher data transmission rates, disregarding the EMC limitation of the LIN network. The Software Flash Mode can be used for programming the external microcontroller via the LIN bus, got example during the production flow of the ECU.

The Software Flash Mode can only be entered from Normal Slope Mode (see [Figure 3](#)). By setting the EN pin to low for the time t_{fl1} and by generating a falling and a rising edge at the TxD pin with the time t_{fl2} and t_{fl3} during the low phase of the EN pin, the TLE8458 changes to the Software Flash Mode (see [Figure 5](#)). Vice versa, the TLE8458 changes from Software Flash Mode to Normal Slope Mode by applying the same sequence to the EN pin and the TxD pin.

In any case, regardless if the device is in Normal Slope Mode or in Software Flash Mode, a LOW signal on the EN pin changes the operation mode to Sleep Mode or Stop Mode. The slope control mechanism will be activated, when the device changes to the Normal Operation Mode again.

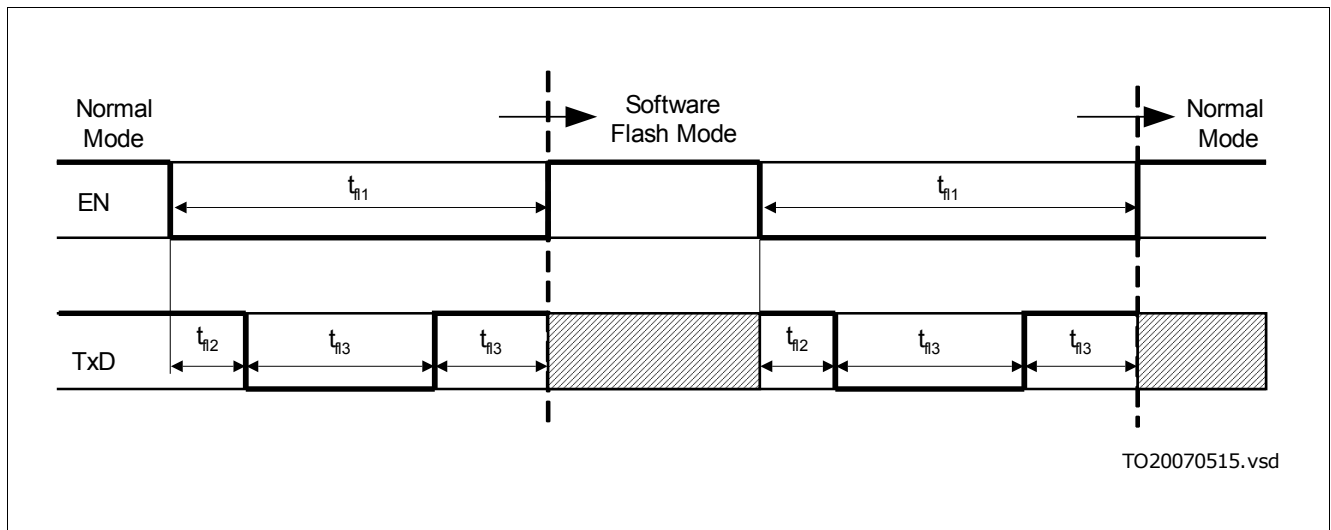

Figure 5 Software Flash Mode

5.2.3 Stop Mode

The Stop Mode is a Low Power Mode, meaning the quiescent current of the TLE8458 is reduced to a minimum, while the device is still able to recognize Wake-up events. The following functions are available in Stop Mode:

- The power supply V_{CC} is active and functional.
- The LIN transceiver output stage is disabled, no communication to the LIN bus is possible.
- The LIN transceiver input receiver is disabled.
- The internal LIN bus termination is switched off.
- The TxD input and the RxD output is inactive.
- The EN input is active. A HIGH signal on the EN pin changes the operation mode to Normal Operation Mode.
- The LIN bus Wake-up receiver is active, a Wake-up event on the LIN bus changes the operation mode to Stand-By Mode.
- The wake input WK is active, a Wake-up event on the WK pin changes the operation mode to Stand-By Mode.

Entering Stop Mode is only possible from the Normal Operation Mode, regardless if the device is in Normal Slope Mode or Software Flash Mode. Setting the signal on the EN pin to LOW, followed by a LOW signal on the TxD pin for the time t_{Mode1} changes the operation mode to Stop Mode (see [Figure 4](#)).

5.2.4 Sleep Mode

The Sleep Mode is a Low Power Mode as well, in comparison to the Stop Mode, the quiescent current of the TLE8458 is even further reduced. In Sleep Mode the TLE8458 is able as well to recognize Wake-up events.

The Wake-up behavior in Sleep Mode is the same as in Stop Mode. The only difference between Sleep Mode and Stop Mode is, that in Stop Mode the output voltage V_{CC} is active, in Sleep Mode the output voltage V_{CC} is disabled.

Sleep Mode can be entered from Normal Operation Mode by setting the EN pin to LOW and simultaneously setting the TxD pin to HIGH for the time t_{Mode1} (see [Figure 4](#)). The Sleep Mode can be also entered from Stop Mode, by setting the signal on the TxD pin to HIGH for the time t_{Mode1} .

5.2.5 Wake-up Events in Sleep and Stop Mode

A Wake-up event in Sleep Mode or Stop Mode changes the operation mode of the TLE8458 to Stand-By Mode. There are 3 different options to Wake-up the TLE8458 from Sleep Mode or Stop Mode:

- A bus Wake-up event, caused by a message on the LIN bus.
- A local Wake-up event, caused by a logical LOW signal on the WK pin.
- A signal change to logical HIGH on the EN pin.

5.2.5.1 Bus Wake-up Event

A falling edge on the LIN bus, followed by a dominant bus signal for the time $t > t_{wk,Bus}$ causes a bus Wake-up or also called remote Wake-up. The mode change becomes active with the following rising edge on the LIN bus (see [Figure 6](#)). In Stand-By Mode the Wake-up source is indicated by the TxD and RxD pins (see [Table 6](#)).

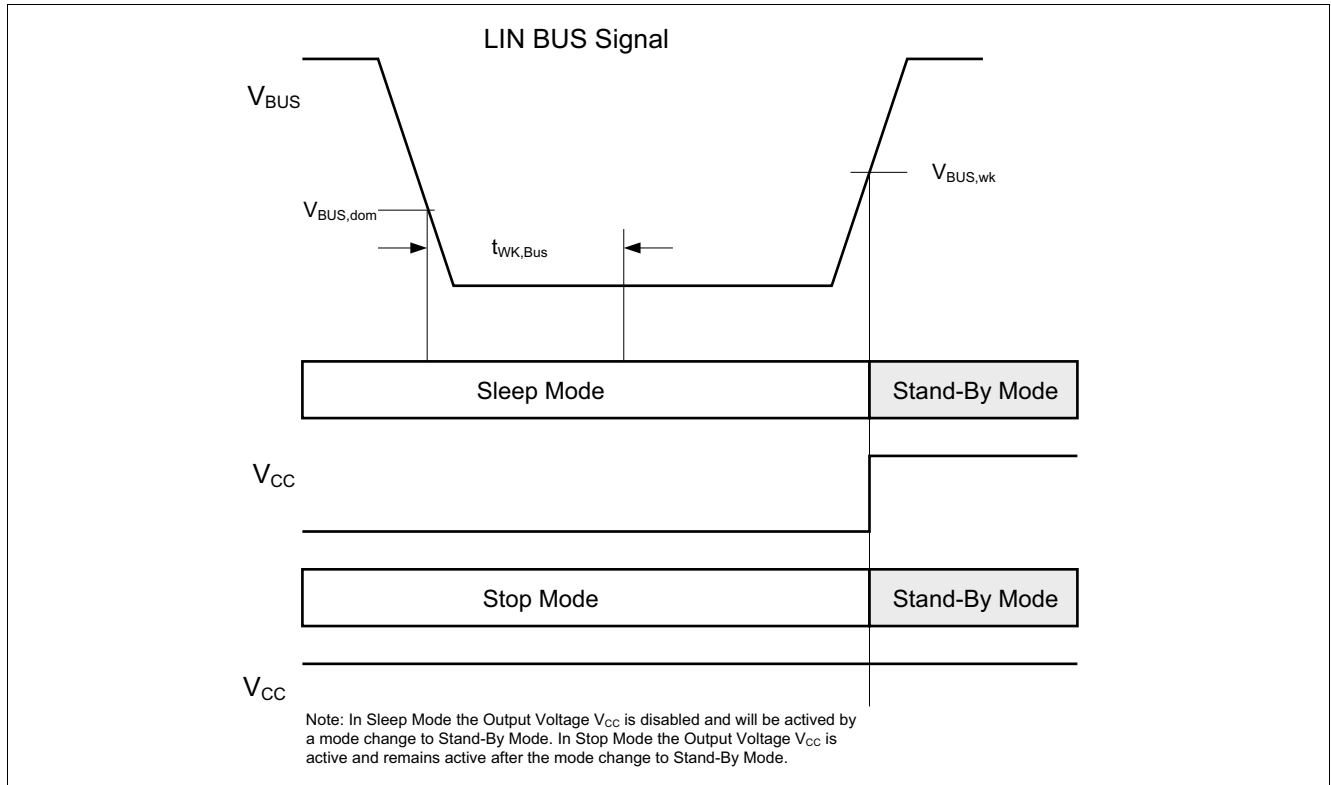

Figure 6 Bus Wake-up

5.2.5.2 Local Wake-up Event

A Wake-up via LOW signal on the pin WK is called local Wake-up. A falling edge of the signal on the pin WK followed by a LOW signal for the time $t > t_{WK}$ change the operation mode from Sleep Mode or Stop Mode to Stand-By Mode. In the case the LOW signal is shorter then the time $t < t_{WK}$, the Wake-up is ignored and the TLE8458 remains in Sleep Mode or Stop Mode. In Stand-By Mode the Wake-up source is indicated by the TxD and RxD pins (see [Table 6](#)). In order to avoid unintended Wake-up's via the local wake pin Wk, the Wk pin should get connected by a serial resistor to the power supply V_s (see [Figure 15](#)). Before the TLE8458 enters into Sleep Mode it is required to set the Voltage on the WK pin to the V_s power supply.

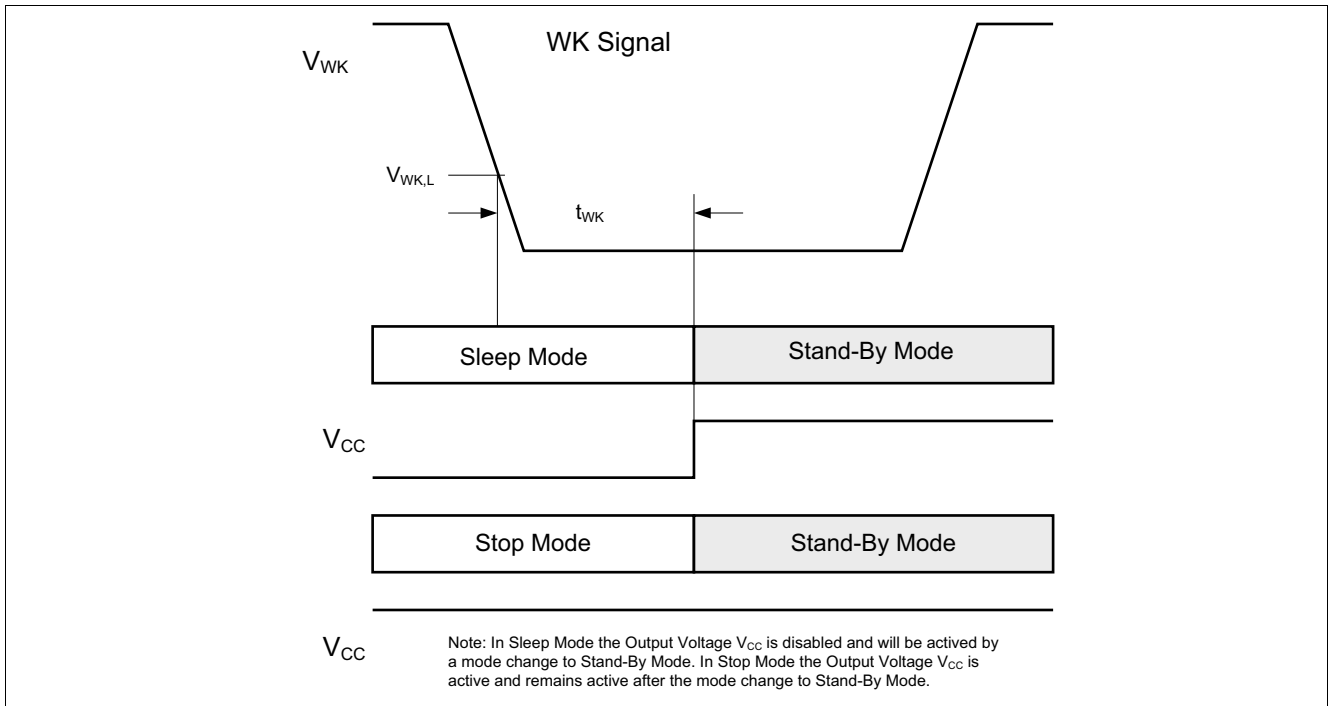

Figure 7 Local Bus Wake-up

5.2.5.3 Mode Transition via EN pin

The EN pin is used for the mode selection. In case the power supply V_{CC} is present, like in Stop Mode or Sleep Mode, the TLE8458 can be directly transferred into Normal Operation Mode by setting the EN pin to HIGH. An integrated pull-down resistor at the EN pin avoids mode changes due to floating signals on the EN input. The TLE8458 changes the operation mode to Normal Operation Mode, from Stop Mode or from Sleep Mode if the EN pin is HIGH for the time $t > t_{Mode1}$ (see Figure 8). An integrated hysteresis on the EN pin avoids bit toggling. The mode transition via the EN pin will not be indicated in Stand-By Mode.

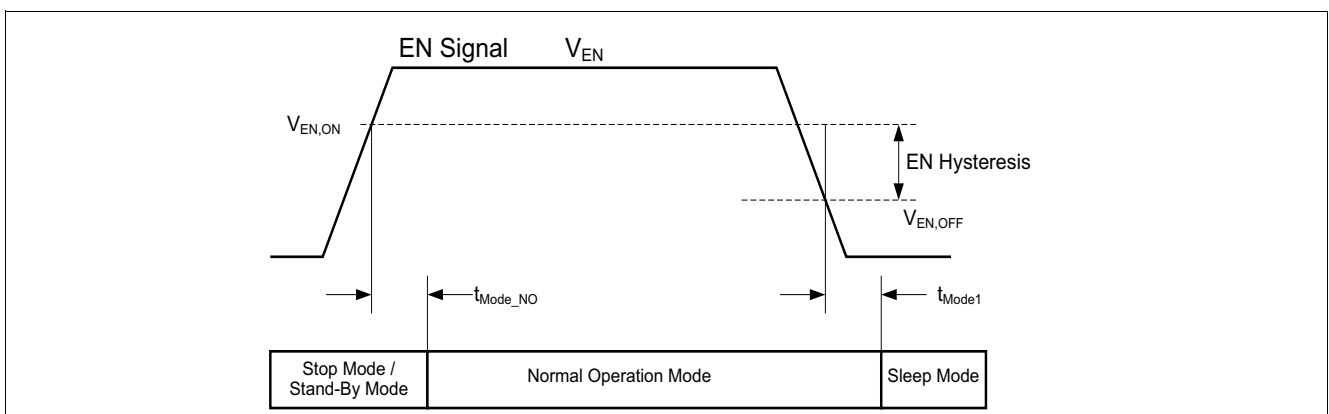

Figure 8 Mode Transition via EN pin

5.2.6 Power Up

After a Power-up the device enters per default into Stand-By Mode. Above $V_{S,PU}$ the V_{CC} output voltage follows the supply V_S closely. In Stand-By Mode, the Power-up is indicated by a HIGH signal on the RxD pin and a LOW signal on the TxD pin.

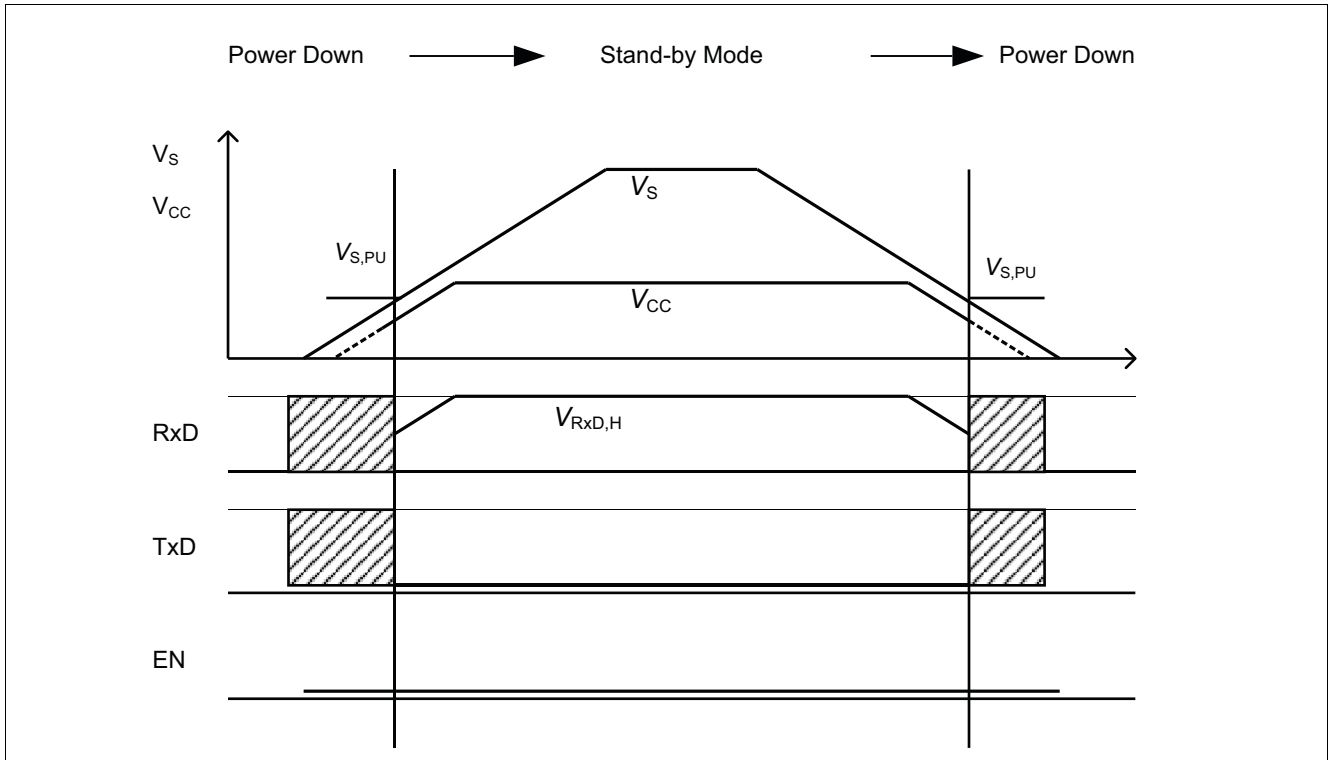

Figure 9 Power-up Level

5.2.7 Over-Temperature Protection

The TLE8458 is protected against thermal over-heating. Over-heating could be caused by a short circuit on the V_{CC} power supply or by a permanent short on the LIN bus combined with a high ambient temperature. In case of an over-temperature event, the TLE8458 eliminates the root cause of the over-temperature event. Two different temperature sensors are implemented inside the TLE8458. One temperature sensor protects the voltage regulator and controls the output voltage V_{CC} , the second temperature sensor protects the LIN transmitter output stage.

In case the junction temperature on the LIN output stage raises above the threshold $T > T_{SD,LIN}$, the temperature sensor disables the LIN output stage. The TLE8458 is still able to receive data from the LIN bus. If the temperature falls below the threshold, $T < T_{SD,LIN}$, the output stage will be enabled and the communication can start again. An integrated hysteresis on the temperature sensor avoids toggling during over-temperature events. An over-temperature event on the LIN bus will not cause any operation mode change.

In case the junction temperature on the V_{CC} power output stage raises above the threshold $T > T_{SD,VCC}$, the temperature sensor shuts down the output voltage V_{CC} . If the junction temperature falls below the threshold, $T > T_{SD,VCC}$, the power supply V_{CC} will be enabled again. An integrated hysteresis on the temperature sensor avoids toggling during over-temperature events.

5.3 Current Consumption

Table 7 Electrical Characteristics: Current Consumption

$V_S = 13.5\text{ V}$, $T_j = -40\text{ }^\circ\text{C} \text{ } +150\text{ }^\circ\text{C}$, all voltages with respect to ground, positive current flowing into pin (unless otherwise specified)

Parameter	Symbol	Values			Unit	Note / Test Condition	Number
		Min.	Typ.	Max.			
Current Consumption							
Current Consumption in Normal Mode at V_S in LIN Recessive State	I_{S_rec}	–	1.3	2.2	mA	Recessive state, without R_L ; $V_{TXD} = V_{CC}$; $I_{CC} = 100\text{ }\mu\text{A}$	P_5.3.1
Current Consumption in Normal Mode at V_S in LIN Dominant State	I_{S_dom}	–	1.8	3.2	mA	Dominant state, without R_L ; $V_{TXD} = 0\text{ V}$; $I_{CC} = 100\text{ }\mu\text{A}$	P_5.3.2
Current Consumption at V_S in Sleep Mode	I_{S_sleep}	–	8	12	μA	Sleep Mode, $-40\text{ }^\circ\text{C} < T_j < 85\text{ }^\circ\text{C}$; $V_{LIN} = V_S$; $V_{CC} = 0\text{ V}$	P_5.3.3
Current Consumption at V_S in Stop Mode	I_{S_stop}	–	–	40	μA	Stop Mode; $-40\text{ }^\circ\text{C} < T_j < 85\text{ }^\circ\text{C}$; $V_{LIN} = V_S$; no load on V_{CC}	P_5.3.4
Current Consumption in Sleep Mode, Bus Shorted to Ground	$I_{S_sleep_short}$	6	40	72	μA	Sleep Mode, $V_{LIN} = 0\text{ V}$ $V_{CC} = 0\text{ V}$	P_5.3.5

5.4 Electrical Characteristics EN and WK Pins

Table 8 Electrical Characteristics: Mode Pins

$7\text{ V} < V_S < 27\text{ V}$, $T_j = -40\text{ }^\circ\text{C} + 150\text{ }^\circ\text{C}$, all voltages with respect to ground, positive current flowing into pin (unless otherwise specified)

Parameter	Symbol	Values			Unit	Note / Test Condition	Number
		Min.	Typ.	Max.			
EN Pin							
HIGH Level Input Voltage	$V_{EN,H}$	2	–	–	V	–	P_5.4.6
LOW Level Input Voltage	$V_{EN,L}$	–	–	0.8	V	–	P_5.4.7
EN Input Hysteresis	$V_{EN,hys}$	–	0.3	–	V	–	P_5.4.8
EN pull-down Resistance	R_{EN}	20	40	80	k Ω	–	P_5.4.9
Filter Time for Mode Change	t_{mode1}	50	–	150	μs	–	P_5.4.10
TxD low delay time	t_{mode2}	0	–	50	μs	Stop Mode transfer	P_5.4.11
TxD high time	t_{mode3}	10	–	–	μs	Stop Mode transfer	P_5.4.12
Time for Mode Change from Stop or Sleep Mode to Normal Operation Mode	t_{Mode_NO}	–	10	–	μs	¹⁾ Transfer to Normal Operation Mode	P_5.4.1
Time for Flash Mode activation	t_{fl1}	25	–	50	μs	¹⁾ EN pin low	P_5.4.13
TxD Time for Flash Mode activation	t_{fl2}	5	–	–	μs	¹⁾	P_5.4.14
TxD Time for Flash Mode activation	t_{fl3}	10	–	–	μs	¹⁾	P_5.4.15

WK Pin

High Level Input Voltage	$V_{WK,H}$	$V_S - 1$	–	$V_S + 3$	V	$V_S = 13.5\text{ V}$	P_5.4.16
Low Level Input Voltage	$V_{WK,L}$	-0.3	–	$V_S - 4$	V	$V_S = 13.5\text{ V}$	P_5.4.17
Pull-up Current	$I_{WK,PU}$	-60	-30	-3	μA	$V_{WK} = 0\text{ V}$ $V_S = 13.5\text{ V}$	P_5.4.18
High Level Leakage Current	$I_{WK,L}$	-5	–	5	μA	$V_S = 0\text{ V}$; $V_{WK} = 40\text{ V}$	P_5.4.19
Dominant Time for Wake-up	t_{WK}	30	–	150	μs	–	P_5.4.20

¹⁾ Not subject to production test, specified by design

5.5 Power Up, Power Down

Table 9 Electrical Characteristics: Power-up

$T_j = -40\text{ }^\circ\text{C} + 150\text{ }^\circ\text{C}$, all voltages with respect to ground, positive current flowing into pin (unless otherwise specified)

Parameter	Symbol	Values			Unit	Note / Test Condition	Number
		Min.	Typ.	Max.			
V_S Pin							
V_S Power-up Voltage Threshold	$V_{S,PU}$	–	–	3.5	V	$I_{CC} = 40\text{ mA}$, $V_{CC} > 3.0\text{ V}$	P_5.5.21

6 Voltage Regulator

6.1 Description of Voltage Regulator

The TLE8458G has a monolithic integrated voltage regulator dedicated for microcontroller supplies under harsh automotive environment conditions. Due to its ultra low current consumption, the TLE8458 is perfectly suited for applications permanently connected to a battery. Additionally, the regulator is switched off in Sleep Mode to achieve a very low quiescent current. The TLE8458 is equipped with protection functions against overloading, short circuits, and over temperature.

6.2 Electrical Characteristics of the Voltage Regulator

Table 10 Electrical Characteristics: Voltage Regulator

$V_S = 5.5 \text{ V to } 13.5 \text{ V}$, $T_{j} = -40 \text{ }^\circ\text{C to } +150 \text{ }^\circ\text{C}$, all voltages with respect to ground, positive current flowing into pin (unless otherwise specified)

Parameter	Symbol	Values			Unit	Note / Test Condition	Number
		Min.	Typ.	Max.			
Output Voltage for TLE8458G	$V_{CC,5}$	4.9	5	5.1	V	$1 \text{ mA} < I_{CC} < 50 \text{ mA}$; $5.5 \text{ V} < V_S < 18 \text{ V}$	P_6.2.1
Output Voltage for TLE8458G	$V_{CC,5}$	4.9	5	5.1	V	$I_{CC} = 10 \text{ mA}$; $5.5 \text{ V} < V_S < 40 \text{ V}$	P_6.2.8
Output Voltage for TLE8458GV33	$V_{CC,3,3}$	3.234	3.3	3.366	V	$1 \text{ mA} < I_{CC} < 50 \text{ mA}$; $5.5 \text{ V} < V_S < 18 \text{ V}$	P_6.2.2
Output Voltage for TLE8458GV33	$V_{CC,3,3}$	3.234	3.3	3.366	V	$I_{CC} = 10 \text{ mA}$; $5.5 \text{ V} < V_S < 40 \text{ V}$	P_6.2.9
Output Current Limitation TLE8458G	$I_{CC,lim}$	60	–	–	mA	$V_{CC,5} > 4.5\text{V}$ $V_S = 13.5 \text{ V}$	P_6.2.3
Output Current Limitation TLE8458GV33	$I_{CC,lim}$	50	–	–	mA	$V_{CC,3,3} > 2.8\text{V}$ $V_S = 13.5 \text{ V}$	P_6.2.10
Output Voltage Drop	V_{DR}	–	250	500	mV	$I_{CC} = 40 \text{ mA}^{1)}$	P_6.2.4
Load Regulation	$\Delta V_{CC,LO}$	–	25	50	mV	$1 \text{ mA} < I_{CC} < 50 \text{ mA}$ $V_S = 13.5 \text{ V}$	P_6.2.5
Line Regulation	$\Delta V_{CC,LI}$	–	25	50	mV	$I_{CC} = 1 \text{ mA}$; $6 \text{ V} < V_S < 28 \text{ V}$	P_6.2.6
Power Supply Ripple Rejection	$PSRR$	–	60	–	dB	$f = 100 \text{ Hz}$; $V_r = 0.5 \text{ Vpp}^{2)3)}$	P_6.2.7

1) Measured when the output voltage has dropped 100 mV from the nominal value obtained at $V_S = 13.5 \text{ V}$

2) Voltage of ripple V_r is 0.5 V peak-to-peak

3) Not subject to production test; specified by design.

7 LIN Transceiver

7.1 Functional Description

The LIN Bus is a single wire, bi-directional bus, used for in-vehicle networks. The LIN Transceiver implemented inside the TLE8458 is the interface between the microcontroller and the physical LIN Bus. (see [Figure 1](#) and [Figure 15](#)). The digital output data from the microcontroller are driven to the LIN bus via the TxD input pin on the TLE8458. The transmit data stream on the TxD input is converted to a LIN bus signal with optimized slew rate to minimize the EME level of the LIN network. The RxD output sends back the information from the LIN bus to the microcontroller. The receiver has an integrated filter network to suppress noise on the LIN Bus and to increase the EMI (Electro Magnetic Immunity) level of the transceiver.

Two logical states are possible on the LIN bus according to the LIN Specification 2.1 (see [Figure 10](#)):

In dominant state, the voltage on the LIN bus is set close to the GND level. In recessive state, the voltage on the LIN bus is set close to the supply voltage V_S . By setting the TxD input of the TLE8458 to LOW the transceiver generates a dominant level on the LIN interface pin. The RxD output reads back the signal on the LIN bus and indicates a dominant LIN bus signal with a logical LOW to the microcontroller. Setting the TxD pin to HIGH the transceiver TLE8458 sets the LIN interface pin LIN to the recessive level, at the same time the recessive level on the LIN bus is indicated by a logical "High" on the RxD output.

Every LIN network consists of a master node and one or more slave nodes. To configure the TLE8458 for master node applications, a resistor in the range of 1 k Ω and a reverse diode must be connected between the LIN bus and the power supply V_S . (see [Figure 15](#)).

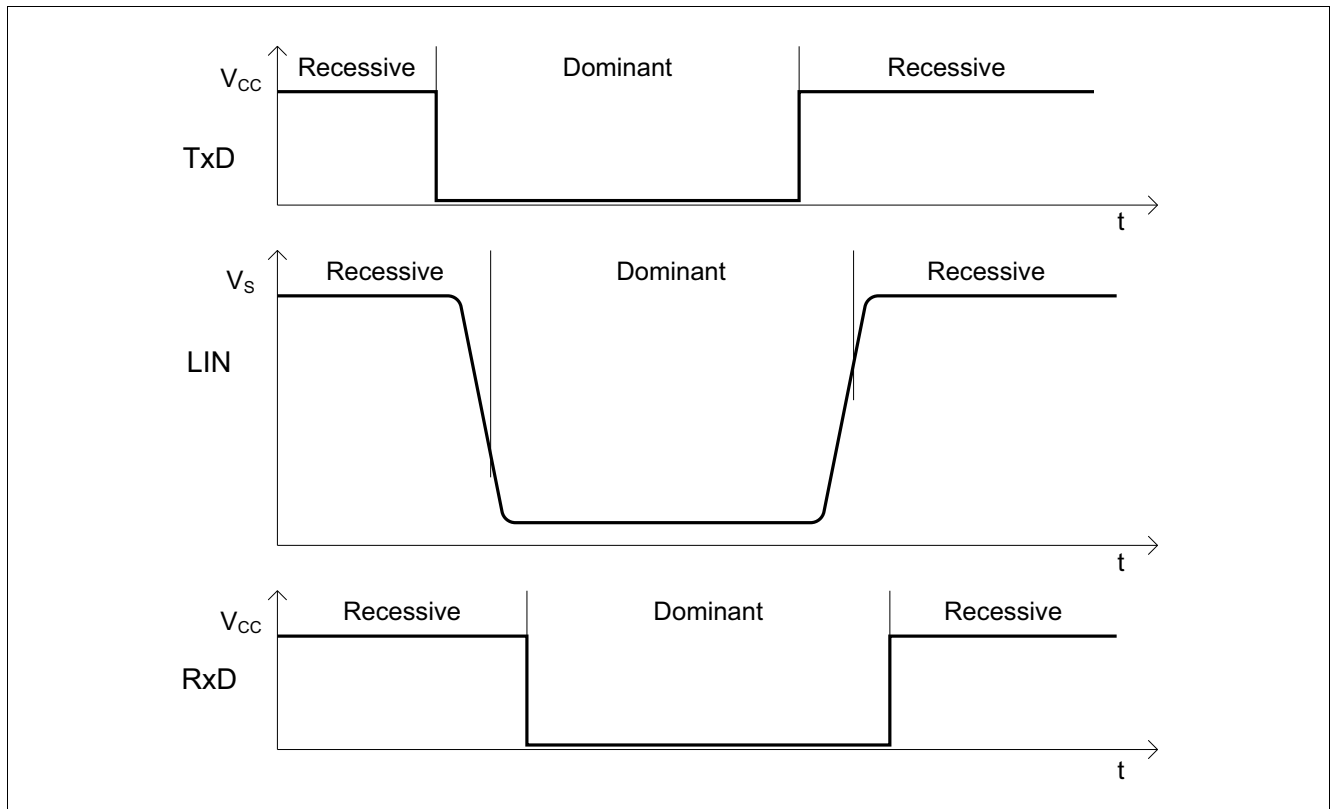

Figure 10 LIN Bus Signals

7.1.1 Undervoltage Detection

A dropping power supply V_S on a local ECU can effect the communication of the whole LIN network. To avoid any blocking of the LIN network by a local ECU the TLE8458 has an integrated Power-On reset at the supply V_S and an undervoltage detection at the supply V_S . In case the supply voltage V_S is dropping below the Power-On reset level $V_S < V_{S,UV,PON}$, the TLE8458 changes the operation mode to Stand-By mode. In Stand-By mode the output stage of the TLE8458 is disabled and no communication to the LIN bus is possible. The internal bus termination remains active as well as the V_{CC} output voltage. (see [Figure 1](#) and [Figure 11](#)).

In Stand-By mode the RxD pin indicates the low power supply condition with a logical HIGH signal. Setting the EN pin to logical HIGH changes the operation mode back to Normal Operation mode.

In case the supply voltage V_S is dropping below the undervoltage reset level $V_S < V_{SUV}$ (see [Figure 11](#)), the TLE8458 disables the output and receiver stages. This feature secures the communication on the LIN bus. If the power supply V_S reaches a higher level as the undervoltage reset level $V_S > V_{SUV}$ the TLE8458 continues with normal operation. A mode change only applies if the power supply V_S drops below the power on reset level ($V_S < V_{S,UV,PON}$).

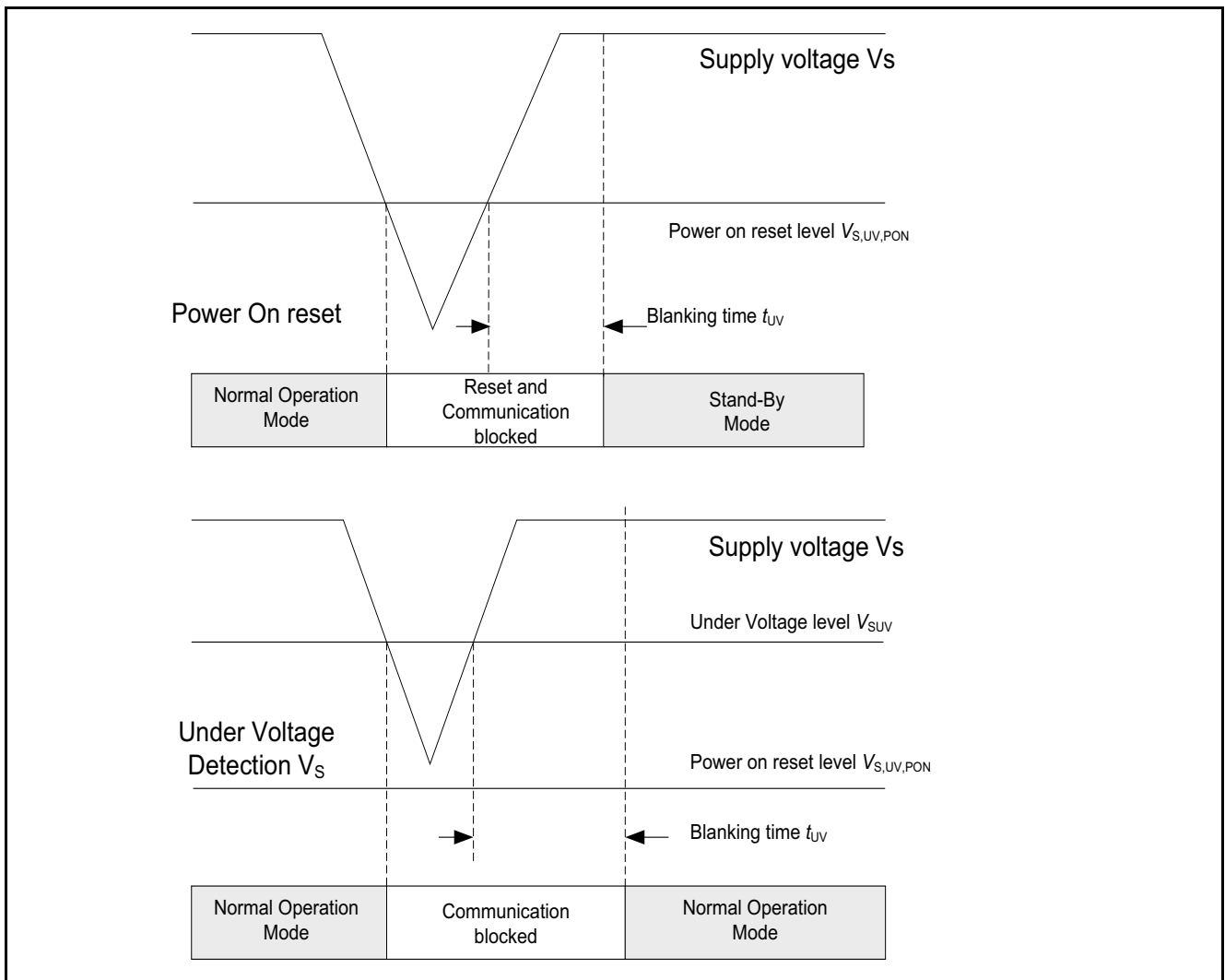

Figure 11 Under-Voltage Detection

7.1.2 TxD Time-Out

If the TxD signal is dominant for the time $t > t_{\text{timeout}}$, the TxD time-out function deactivates the LIN transmitter output stage. The device remains in recessive state. The TxD time-out functions prevents the LIN bus from being blocked by a permanent LOW signal on the TxD pin, caused by a failure. The transmitter output stage is released again, after a rising edge on the TxD pin has been detected (see **Figure 12**).

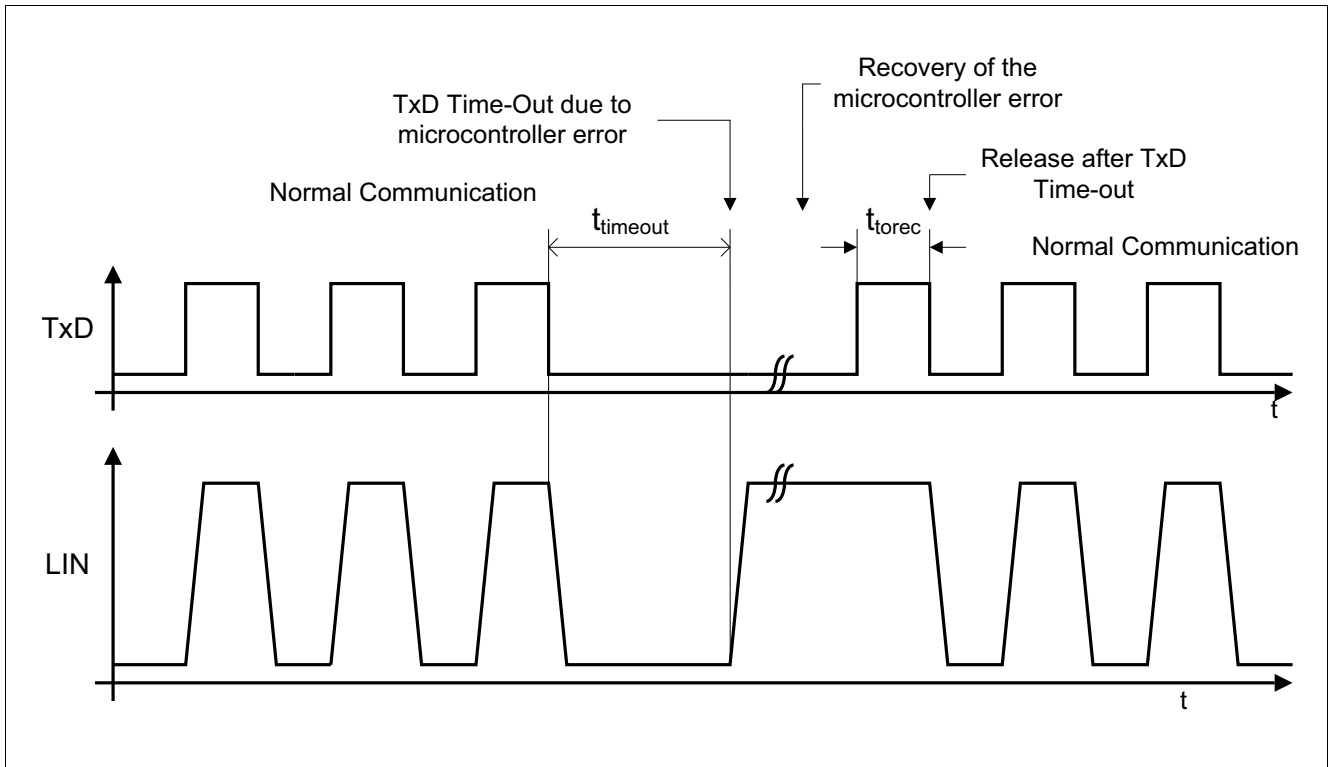

Figure 12 TxD Time-Out function

7.1.3 LIN Specifications

The LIN network is standardized by international regulations. The devices TLE8458G and the TLE8458GV33 are compliant to the specification LIN 2.1. The physical layer specification LIN 2.1 is a super set of the previous LIN specifications, like LIN 2.0 or LIN 1.3. The TLE8458G and the TLE8458GV33 have been qualified according to the LIN 2.1 standard, conformance test results are available on request.

7.2 Electrical Characteristics of the LIN Transceiver

Table 11 Electrical Characteristics: LIN Transceiver Supply

$V_S = 7\text{ V to }27\text{ V}$, $T_{j} = -40\text{ }^{\circ}\text{C to }+150\text{ }^{\circ}\text{C}$, all voltages with respect to ground, positive current flowing into pin (unless otherwise specified)

Parameter	Symbol	Values			Unit	Note / Test Condition	Number
		Min.	Typ.	Max.			
Voltage Supply							
Undervoltage switch-off	V_{SUV}	4	–	5	V	–	P_7.2.1
Power-On Reset Level	$V_{\text{S,UV,PON}}$	2	–	4	V	1)	P_7.2.52
Blanking Time for Under-Voltage switch-off	t_{UV}	–	10	–	μs	1)	P_7.2.2

1) Not subject to production test; specified by design.

Table 12 Electrical Characteristics: LIN Transceiver

$V_S = 7\text{ V to }27\text{ V}$, $T_{j} = -40\text{ }^{\circ}\text{C to }+150\text{ }^{\circ}\text{C}$, $R_L = 500\ \Omega$, all voltages with respect to ground, positive current flowing into pin (unless otherwise specified)

Parameter	Symbol	Values			Unit	Note / Test Condition	Number
		Min.	Typ.	Max.			
Receiver Output (RxD pin)							
HIGH Level Output Voltage	$V_{\text{RxD,H}}$	$0.8 \times V_{\text{CC}}$	–	–	V	$I_{\text{RxD}} = -1.6\text{ mA}$; $V_{\text{bus}} = V_S$	P_7.2.3
LOW Level Output Voltage	$V_{\text{RxD,L}}$	–	–	$0.2 \times V_{\text{CC}}$	V	$I_{\text{RxD}} = 1.6\text{ mA}$ $V_{\text{bus}} = 0\text{ V}$	P_7.2.4
Transmission Input (TxD pin)							
HIGH Level Input Voltage	$V_{\text{TxD,H}}$	$0.7 \times V_{\text{CC}}$	–	–	V	Recessive State	P_7.2.5
TxD Input Hysteresis	$V_{\text{TxD,hys}}$	–	$0.12 \times V_{\text{CC}}$	–	mV	–	P_7.2.6
LOW Level Input Voltage	$V_{\text{TxD,L}}$	–	–	$0.3 \times V_{\text{CC}}$	V	Dominant State	P_7.2.7
TxD Pull-down Resistance	R_{TxD}	–	300	–	k Ω	$V_{\text{TxD}} = 0\text{ V}$	P_7.2.8
TxD Low Level Current (Standby Mode, after Wake-up via WK)	$I_{\text{TxD,L}}$	1.5	3	10	mA	$V_{\text{TxD}} = 0.9\text{ V}$	P_7.2.9

Table 12 Electrical Characteristics: LIN Transceiver (cont'd)
 $V_S = 7\text{ V to }27\text{ V}$, $T_j = -40\text{ }^\circ\text{C to }+150\text{ }^\circ\text{C}$, $R_L = 500\ \Omega$, all voltages with respect to ground, positive current flowing into pin (unless otherwise specified)

Parameter	Symbol	Values			Unit	Note / Test Condition	Number
		Min.	Typ.	Max.			
LIN Bus Receiver (LIN Pin)							
Receiver Threshold Voltage, Recessive to Dominant Edge	$V_{Bus,rd}$	$0.4 \times V_S$	$0.45 \times V_S$	–	V	$V_{Bus,rec} < V_{Bus} < 27\text{ V}$	P_7.2.10
Receiver Dominant State	$V_{Bus,dom}$	–	–	$0.4 \times V_S$	V	LIN2.1 Param. 17	P_7.2.11
Receiver Threshold Voltage, Dominant to Recessive Edge	$V_{Bus,dr}$	–	$0.55 \times V_S$	$0.60 \times V_S$	V	$V_{Bus,rec} < V_{Bus} < 27\text{ V}$	P_7.2.12
Receiver Recessive State	$V_{Bus,rec}$	$0.6 \times V_S$	–	–	V	LIN2.1 Param 18	P_7.2.13
Receiver Center Voltage	$V_{Bus,c}$	$0.475 \times V_S$	$0.5 \times V_S$	$0.525 \times V_S$	V	LIN2.1 Param 19	P_7.2.14
Receiver Hysteresis	$V_{Bus,hys}$	$0.07 \times V_S$	$0.1 \times V_S$	$0.175 \times V_S$	V	$V_{bus,hys} = V_{bus,rec} - V_{bus,dom}$ LIN2.1 Param 20	P_7.2.15
Wake-up Threshold Voltage	$V_{Bus,wk}$	$0.40 \times V_S$	$0.5 \times V_S$	$0.6 \times V_S$	V	–	P_7.2.16
Dominant Time for Bus Wake-up	$t_{WK,Bus}$	30	–	150	μs	–	P_7.2.17
LIN Bus Transmitter (LIN Pin)							
Bus Recessive Output Voltage	$V_{BUS,ro}$	$0.8 \times V_S$	–	V_S	V	$V_{TxD} = \text{high Level}$	P_7.2.18
Bus Dominant Output Voltage	$V_{BUS,do}$	–	–	1.2	V	$V_{TxD} = 0\text{ V}$; $6.0\text{ V} \leq V_S \leq 7.3\text{ V}$;	P_7.2.53
Bus Dominant Output Voltage	$V_{BUS,do}$	–	–	$0.2 \times V_S$	V	$V_{TxD} = 0\text{ V}$; $7.3\text{ V} \leq V_S \leq 10.0\text{ V}$;	P_7.2.19
Bus Dominant Output Voltage	$V_{BUS,do}$	–	–	2.0	V	$V_{TxD} = 0\text{ V}$; $10.0\text{ V} \leq V_S \leq 18.0\text{ V}$;	P_7.2.20
Bus Short Circuit Current	$I_{BUS,sc}$	40	100	150	mA	$V_{BUS} = 13.5\text{ V}$; LIN2.1 Param 12	P_7.2.23
Leakage Current Loss of Ground	$I_{BUS,lg}$	-1000	-450	0	μA	$V_S = 0\text{ V}$; $V_{BUS} = -12\text{ V}$; LIN2.1 Param 15	P_7.2.24
Leakage Current Loss of Battery	$I_{BUS,lg}$	–	–	5	μA	$V_S = 0\text{ V}$; $V_{BUS} = 18\text{ V}$; LIN2.1 Param 16	P_7.2.25
Leakage Current	$I_{BUS,lg}$	-1	–	–	mA	$V_S = 18\text{ V}$; $V_{BUS} = 0\text{ V}$; LIN2.1 Param 13	P_7.2.26
Leakage Current Driver Off	$I_{BUS,lg}$	–	–	5	μA	$V_S = 8\text{ V}$; $V_{BUS} = 18\text{ V}$; LIN2.1 Param 14	P_7.2.27
Bus Pull-up Resistance	R_{BUS}	20	30	47	k Ω	Normal Mode LIN2.1 Param 26	P_7.2.28

Table 12 Electrical Characteristics: LIN Transceiver (cont'd)
 $V_S = 7\text{ V to }27\text{ V}$, $T_j = -40\text{ }^\circ\text{C to }+150\text{ }^\circ\text{C}$, $R_L = 500\ \Omega$, all voltages with respect to ground, positive current flowing into pin (unless otherwise specified)

Parameter	Symbol	Values			Unit	Note / Test Condition	Number
		Min.	Typ.	Max.			
LIN Output Current	I_{BUS}	-60	-30	-5	μA	Sleep Mode $V_S = 12\text{ V}$; $\text{EN} = 0\text{ V}$; $V_{\text{LIN}} = 0\text{ V}$	P_7.2.29
LIN Input Capacitance	C_{BUS}		15		pF	¹⁾	P_7.2.55
Receiver propagation delay bus dominant to RxD LOW	$t_{\text{d(L),R}}$	–	1	6	μs	$C_{\text{RxD}} = 20\text{ pF}$; LIN2.1 Param 31	P_7.2.38
Receiver propagation delay bus recessive to RxD HIGH	$t_{\text{d(H),R}}$	–	1	6	μs	$C_{\text{RxD}} = 20\text{ pF}$; LIN2.1 Param 31	P_7.2.39
Receiver delay symmetry	$t_{\text{sym,R}}$	-2	–	2	μs	$t_{\text{sym,R}} = t_{\text{d(L),R}} - t_{\text{d(H),R}}$; LIN2.1 Param 32	P_7.2.40
TxD Dominant Time Out	t_{timeout}	6	12	20	ms	$V_{\text{TxD}} = 0\text{ V}$	P_7.2.44
TxD Dominant Time Out Recovery Time	t_{torec}	–	10	–	μs	¹⁾	P_7.2.45
Duty Cycle D1 (For worst case at 20 kbit/s) LIN2.1 Normal Slope	D1	0.396	–	–		²⁾ $\text{TH}_{\text{Rec}}(\text{max}) = 0.744 \times V_S$; $\text{TH}_{\text{Dom}}(\text{max}) = 0.581 \times V_S$; $V_S = 7.0 \dots 18\text{ V}$; $t_{\text{bit}} = 50\ \mu\text{s}$; $\text{D1} = t_{\text{bus_rec}(\text{min})}/2 t_{\text{bit}}$; LIN2.1 Param 27	P_7.2.46
Duty Cycle D2 (for worst case at 20 kbit/s) LIN2.1 Normal Slope	D2	–	–	0.581		²⁾ $\text{TH}_{\text{Rec}}(\text{min.}) = 0.422 \times V_S$; $\text{TH}_{\text{Dom}}(\text{min.}) = 0.284 \times V_S$; $V_S = 7.6 \dots 18\text{ V}$; $t_{\text{bit}} = 50\ \mu\text{s}$; $\text{D2} = t_{\text{bus_rec}(\text{max})}/2 t_{\text{bit}}$; LIN2.1 Param 28	P_7.2.47

¹⁾ Not subject to production test, specified by design.

²⁾ Bus load conditions concerning LIN spec 2.1 C_{LIN} , $R_{\text{LIN}} = 1\text{ nF}$, $1\text{ k}\Omega$ / 6.8 nF , $660\ \Omega$ / 10 nF , $500\ \Omega$

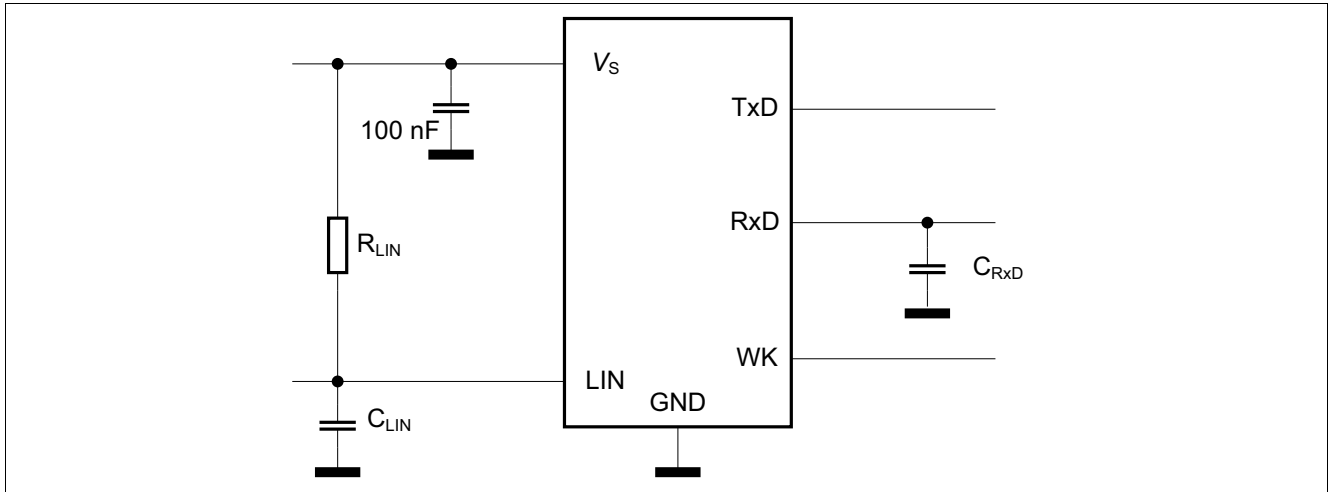

Figure 13 Simplified Test Circuit for Dynamic Characteristics

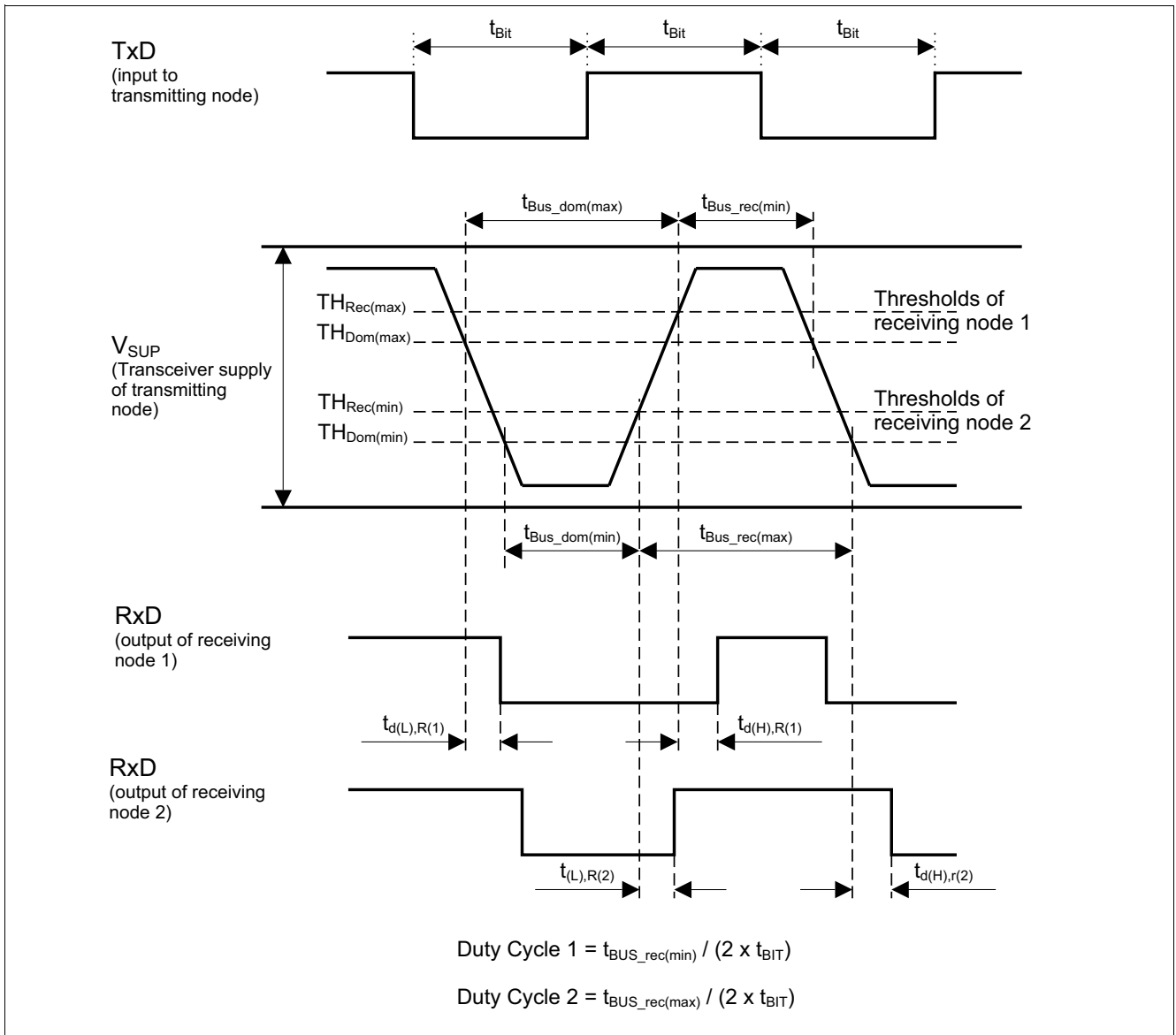

Figure 14 Timing Diagram for Dynamic Characteristics

8 Application Information

Note: The following information is given as a hint for the implementation of the device only and should not be regarded as a description or warranty of a certain functionality, condition or quality of the device.

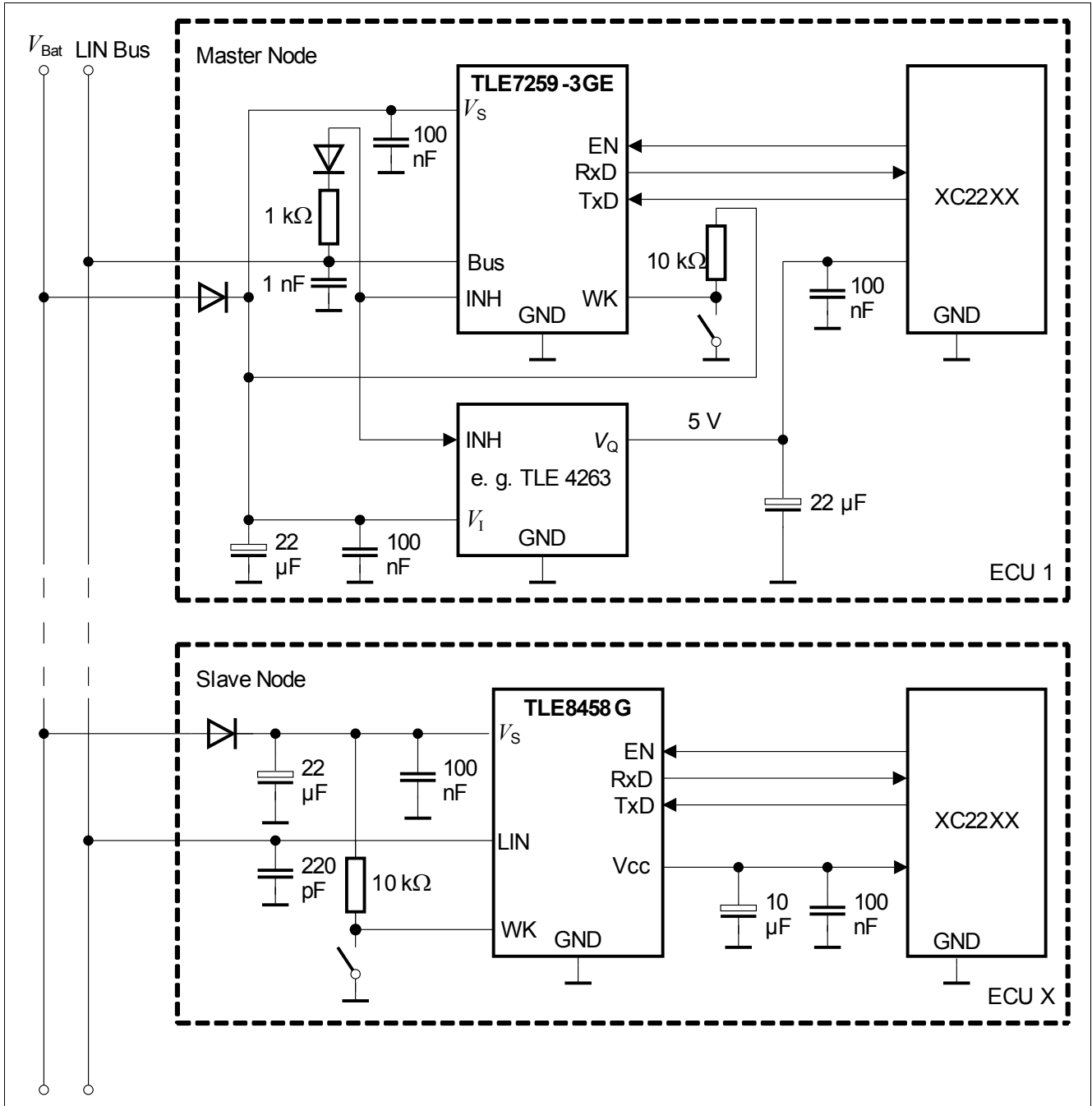

Figure 15 Application Example

Note: This is a simplified example of an application circuit. The function must be verified in the actual application.

8.1 ESD Tests

Test for ESD robustness according to IEC61000-4-2 “Gun test” (150 pF, 330 Ω) have been performed. The results and test conditions are available in a separate test report (see [Table 13](#)).

Table 13 ESD “Gun test”

Parameter	Symbol	Values			Unit	Note / Test Condition	Number
		Min.	Typ.	Max.			
Performed Test							
ESD at V_S , LIN versus GND	$V_{ESD,GUN}$	-10	–	10	kV	GUN ¹⁾	P_8.1.1
ESD at WK PIN	$V_{ESD,GUN}$	-6	–	6	kV	GUN ¹⁾	P_8.1.1

1) ESD susceptibility “ESD GUN” according LIN EMC Test Specification, Section 3.4.3 (IEC 61000-4-2:2001-12), tested by external test house (IBEE Zwickau, EMC Test report Nr. 05-12-13a)

8.1.1 EMC Measurement

The EMC performance has been qualified by an external test house according to the LIN EMC Test specification Version 1.0 (August 1, 2004). For the DPI measurements according to the LIN EMC Test Specification, Section 4.2 (ISO62132 part 1: 2006, ISO62132 part 4: 2006) the verification limit for the output voltage V_{CC} , was set to a limit of +/- 100 mV. External test reports are available on request.

8.2 Pin Compatibility to Stand-Alone LIN transceivers

The TLE8458G is pin - and function compatible to the single LIN transceivers like the TLE7259-3GE (see [Figure 16](#)). Instead of the INH output pin on the single LIN transceiver TLE7259-3GE the V_{CC} power supply output can be connected to the external microcontroller. The TLE8458G provides the same operation modes and features as single LIN transceiver TLE7259-3GE.

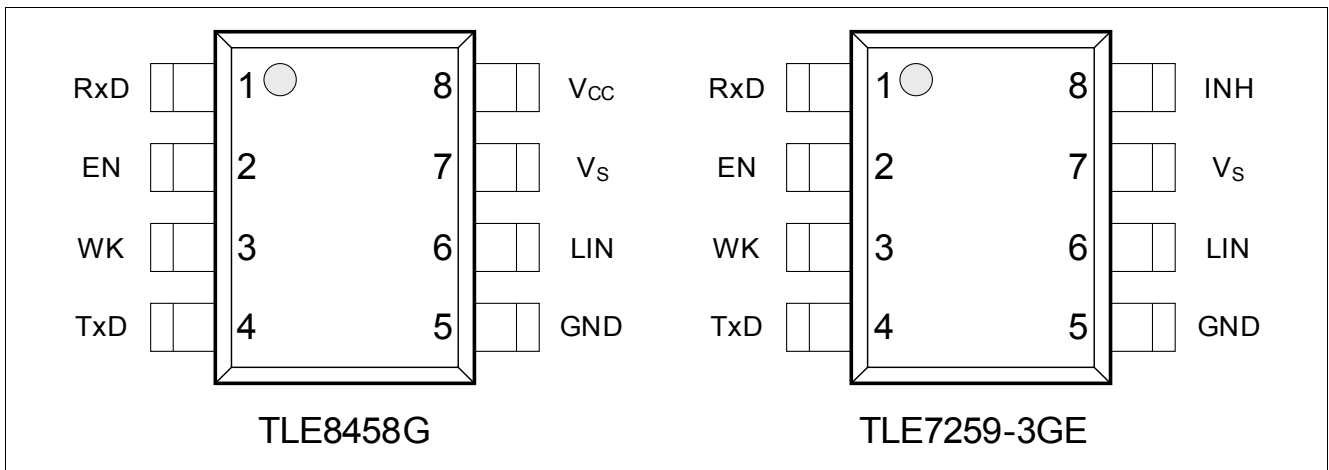

Figure 16 Pinning of TLE8458G versus the TLE7259-3GE

9 Package Outlines

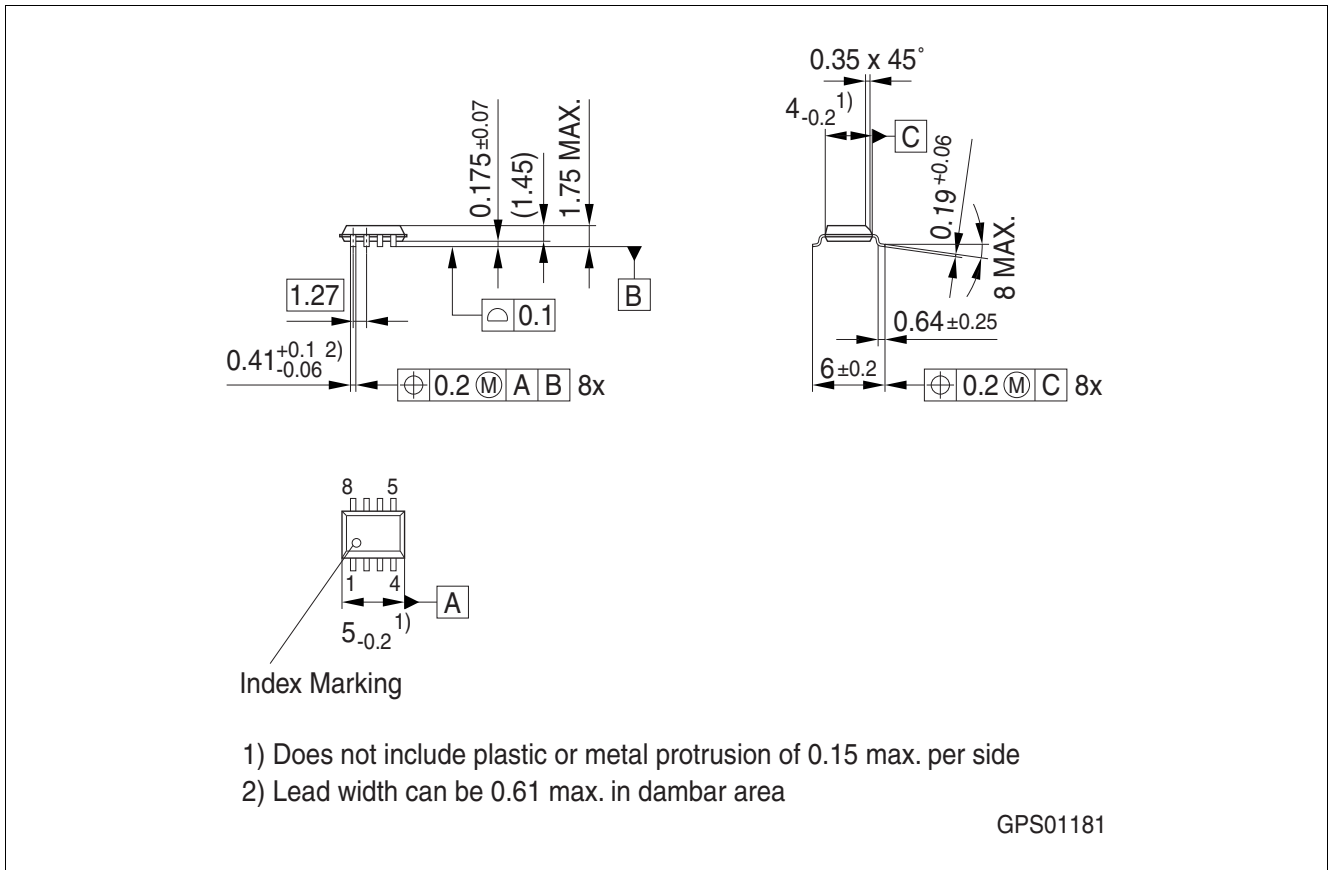

Figure 17 PG-DSO-8-16 (SO-8 Standard, Green (RoHS compliant))

Green Product (RoHS compliant)

To meet the world-wide customer requirements for environmentally friendly products and to be compliant with government regulations the device is available as a green product. Green products are RoHS-Compliant (i.e. Pb-free finish on leads and suitable for Pb-free soldering according to IPC/JEDEC J-STD-020).

For further information on alternative packages, please visit our website:
<http://www.infineon.com/packages>.

Dimensions in mm

10 Revision History

Revision	Date	Changes
1.1	2014-04-01	All pages: - Editorial changes, updated with latest Infineon style guide Updated compatibility with stand alone transceiver with TLE7259-3G Updated condition for Parameter P_5.3.4: no load on V_{CC} Removed device versions TLE8458GU and -GUV33, references and description Removed LIN Duty Cycle parameters D3 and D4 (only applicable to -GU and -GUV33) Chapter 8.1: Updated ESD and EMC references to the latest IBEE test report
1.02	2010-03-08	all pages: Editorial changes table 10: changed Output current limitation min. to 60 mA table 11: changed power on reset values figure 15: deleted 2 resistors
1.01	2009-04-28	Editorial Change to the data sheet Update table 13 on page 30. P_8.1.1 performed test changed from: "ESD at LIN Pin" to: "ESD at V_S , LIN versus GND"
1.0	2009-03-23	Initial data sheet

Edition 2014-04-01

**Published by
Infineon Technologies AG
81726 Munich, Germany**

**© 2014 Infineon Technologies AG
All Rights Reserved.**

Legal Disclaimer

The information given in this document shall in no event be regarded as a guarantee of conditions or characteristics. With respect to any examples or hints given herein, any typical values stated herein and/or any information regarding the application of the device, Infineon Technologies hereby disclaims any and all warranties and liabilities of any kind, including without limitation, warranties of non-infringement of intellectual property rights of any third party.

Information

For further information on technology, delivery terms and conditions and prices, please contact the nearest Infineon Technologies Office (www.infineon.com).

Warnings

Due to technical requirements, components may contain dangerous substances. For information on the types in question, please contact the nearest Infineon Technologies Office.

The Infineon Technologies component described in this Data Sheet may be used in life-support devices or systems and/or automotive, aviation and aerospace applications or systems only with the express written approval of Infineon Technologies, if a failure of such components can reasonably be expected to cause the failure of that life-support automotive, aviation and aerospace device or system or to affect the safety or effectiveness of that device or system. Life support devices or systems are intended to be implanted in the human body or to support and/or maintain and sustain and/or protect human life. If they fail, it is reasonable to assume that the health of the user or other persons may be endangered.