

Door Module Power IC TLE 8201R

Data Sheet Rev. 2.0

Features

- Full bridge (150mΩ) for main doorlock motor
- Two half-bridges (400mΩ) for deadbolt and mirror position motor or mirror fold motor
- Two half-bridges (800mΩ) for mirror position
- High-side switch (100mΩ) for mirror defrost
- Four high-side switches (500mΩ) for 5W and 10W lamps
- Current sense analog output with multiplex
- All outputs with short circuit protection and diagnosis
- Over-temperature protection with warning
- Open load diagnosis for all outputs
- Charge pump-Output for n-channel MOS-FET reverse-polarity protection
- Very low current consumption in sleep mode
- Standard 16-bit SPI for control and diagnosis
- Over- and Undervoltage Lockout
- Power-SO package with full-size heatslug for excellent low thermal resistance

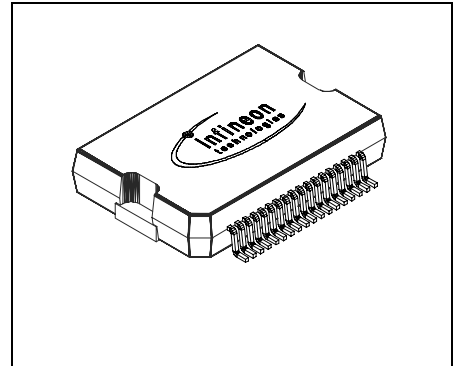

| Type | Ordering Code | Package/Shipment |
|-----------|---------------|------------------|
| TLE 8201R | - | PG-DSO-36-27 |

Functional Description

The TLE 8201R is an Application Specific Standard Product for automotive door-module applications. It includes all the power stages necessary to drive the loads in a typical front door application, i.e. central lock, deadlock or mirror fold, mirror position, mirror defrost and 5W or 10W lamps, e.g for turn signal, courtesy/warning or control panel illumination. It is designed as a monolithic circuit in Infineons mixed technology SPT which combines bipolar and CMOS control circuitry with DMOS power devices.

Short circuit and over-temperature protection and a detailed diagnosis are in line with the safety requirements of automotive applications. The current sense output allows to improve the total system performance. The standard SPI interface saves microcontroller I/O lines while still giving flexible control of the power stages and a detailed diagnosis.

| Table of Contents | | Page |
|--------------------------|---|-------------|
| 1 | Block Diagram | 3 |
| 2 | Pin Configuration | 4 |
| 2.1 | Pin Assignment | 4 |
| 2.2 | Pin Definitions and Functions | 5 |
| 3 | Electrical Characteristics | 7 |
| 3.1 | Absolute Maximum Ratings | 7 |
| 3.2 | Operating Range | 8 |
| 3.3 | Thermal Resistance | 8 |
| 4 | Block Description and Electrical Characteristics | 9 |
| 4.1 | Power Supply | 9 |
| 4.1.1 | General | 9 |
| 4.1.2 | Sleep-Mode | 9 |
| 4.1.3 | Reverse Polarity | 9 |
| 4.1.4 | Electrical Characteristics | 9 |
| 4.2 | Monitoring Functions | 11 |
| 4.2.1 | Power Supply Monitoring | 11 |
| 4.2.2 | Temperature Monitoring | 12 |
| 4.2.3 | Current Sense | 13 |
| 4.3 | SPI | 14 |
| 4.3.1 | General | 14 |
| 4.3.2 | Register Address | 14 |
| 4.3.3 | SPI bit definitions | 16 |
| 4.3.4 | Status Register Address selection and Reset | 20 |
| 4.3.5 | Electrical Characteristics | 21 |
| 4.3.6 | PWM inputs | 22 |
| 4.4 | Power-Outputs 1-6 (Bridge Outputs) | 25 |
| 4.4.1 | Protection and Diagnosis | 25 |
| 4.4.2 | Electrical Characteristics | 27 |
| 4.5 | Power-Output 7 (Mirror heater driver) | 31 |
| 4.5.1 | Protection and Diagnosis | 31 |
| 4.5.2 | Electrical Characteristics | 33 |
| 4.6 | Power-Outputs 8 - 11 (Lamp drivers) | 35 |
| 4.6.1 | Protection and Diagnosis | 35 |
| 4.6.2 | Electrical Characteristics | 38 |
| 4.7 | Logic In- and Outputs | 40 |
| 4.7.1 | Electrical Characteristics | 40 |
| 5 | Application Description | 41 |
| 6 | Package Outlines | 43 |

1 Block Diagram

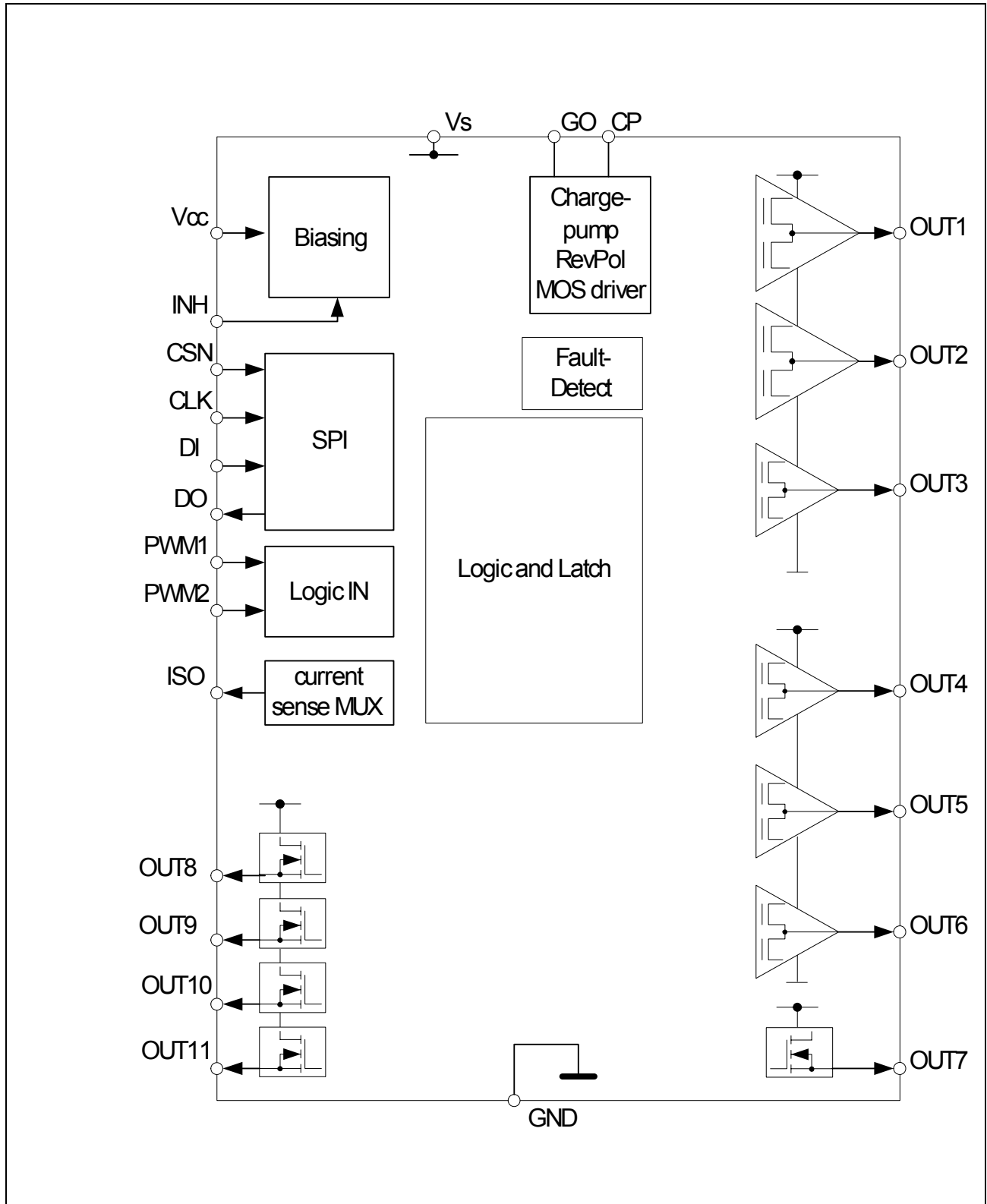

Figure 1 Block Diagram

2 Pin Configuration

2.1 Pin Assignment

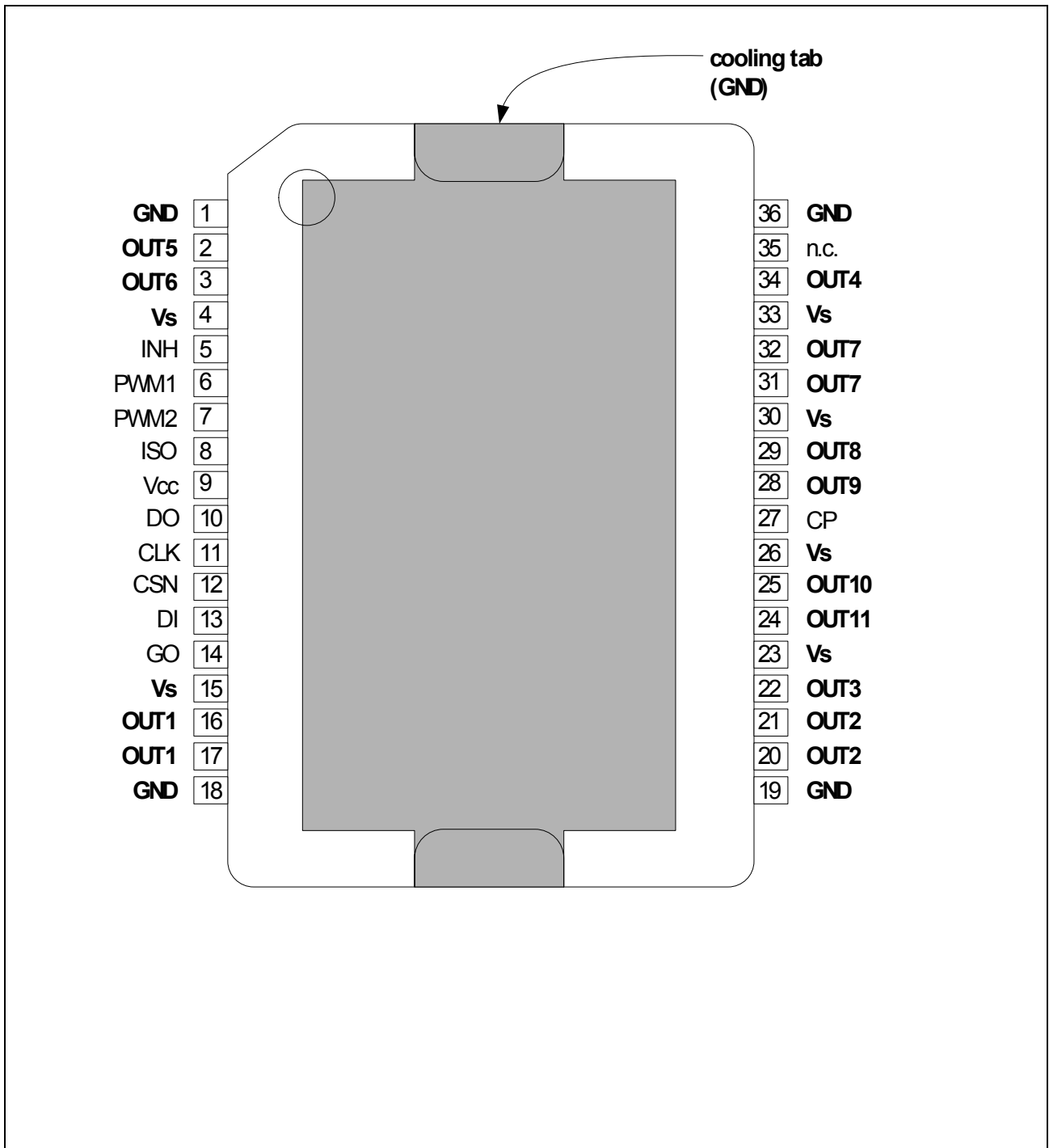

Figure 2 Pin Configuration PG-DSO-36-27

2.2 Pin Definitions and Functions

| Pin | Symbol | Function |
|-----------------------|--------|---|
| cooling tab | GND | Cooling tab , internally connected to GND; to reduce thermal resistance place cooling areas and thermal vias on PCB. |
| 1, 18, 19, 36 | GND | Ground ; internally connected to cooling tab (heat slug). |
| 2 | OUT5 | Power-Output of half-bridge 5 ; DMOS half-bridge |
| 3 | OUT6 | Power-Output of half-bridge 6 ; DMOS half-bridge. |
| 4, 15, 23, 26, 30, 33 | Vs | Power supply ; needs decoupling capacitors to GND. > 47µF electrolytic in parallel with 100nF ceramic is recommended. All Vs pins must be connected externally |
| 5 | INH | Inhibit ; active low. Sets the device in sleep mode with low current consumption when left open or pulled to LOW. Has an internal pull down current source |
| 6 | PWM1 | Logic Input for direct power stage control ; direct input to control the high-side switches selected by the SPI xsel1 bits in control register CtrlReg01 |
| 7 | PWM2 | Logic Input for direct power stage control ; direct input to control the switches selected by the SPI xsel2 bits in control register CtrlReg11 |
| 8 | ISO | Current sense output ; Mirrors the current of the high-side switch selected by the current sense multiplexer control bits ISx |
| 9 | Vcc | Logic Supply Voltage ; needs decoupling capacitors to GND (pin 1). 10µF electrolytic in parallel with 10nF ceramic is recommended |
| 10 | DO | Serial Data Output ; Transfers data to the master when the chip is selected by CSN=LOW. Data transmission is synchronized by CLK, DO state is changed on the rising edge of CLK. The most significant bit (MSB) is transferred first. The pin is tristated as long as CSN=HIGH |
| 11 | CLK | Serial Data Clock Input ; Receives the clock signal from the master and clocks the SPI shift register. Has an internal pull down current source |
| 12 | CSN | Serial Port Chip Select Not Input ; SPI communication is enabled by pulling CSN to LOW. CLK must be LOW during the transition of CSN. The CSN-pin has an internal pull-up current source |

Pin Configuration

| Pin | Symbol | Function |
|--------|--------|--|
| 13 | DI | Serial Data Input ; Receives serial data from the master when the chip is selected by CSN=LOW. Data transmission is synchronized by CLK. Data are accepted on the falling edge of CLK. The LSB is transferred first. The DI-pin has an internal pull-down current source. |
| 14 | GO | Gate Out ; Charge pump output to drive the gate of external n-channel MOS-FET for reverse polarity protection |
| 16, 17 | OUT1 | Power-Output of half-bridge 1 ; DMOS half-bridge. |
| 20, 21 | OUT2 | Power-Output of half-bridge 2 ; DMOS half-bridge. |
| 22 | OUT3 | Power-Output of half-bridge 3 ; DMOS half-bridge |
| 24 | OUT11 | Power Output of high-side switch 11 ; DMOS high-side switch |
| 25 | OUT10 | Power Output of high-side switch 10 ; DMOS high-side switch |
| 27 | CP | Charge Pump ; pin for optional external charge-pump reservoir capacitor. 3.3 nF to Vs is recommended |
| 28 | OUT9 | Power-Output of high-side switch 9 ; DMOS high-side switch |
| 29 | OUT8 | Power-Output of high-side switch 8 ; DMOS high-side switch |
| 31, 32 | OUT7 | Power Output of high-side switch 7 ; DMOS high-side switch |
| 34 | OUT4 | Power-Output of half-bridge 4 ; DMOS half-bridge |
| 35 | n.c. | Not connected |

3 Electrical Characteristics

3.1 Absolute Maximum Ratings

| Pos. | Parameter | Symbol | Limit Values | | Unit | Remarks |
|-------|---|-----------|--------------|-----------|------|---|
| | | | min. | max. | | |
| 3.1.1 | Supply voltage | V_S | -0.3 | 40 | V | – |
| 3.1.2 | Logic supply Voltage | V_{CC} | -0.3 | 5.5 | V | – |
| 3.1.3 | Logic input- and output Voltages | | -0.3 | 5.5 | V | – |
| 3.1.4 | Voltage at GO-pin | V_{GO} | -16 | $V_S + 5$ | V | – |
| 3.1.5 | Junction temperature | T_j | -40 | 150 | °C | – |
| 3.1.6 | Storage temperature | T_{stg} | -50 | 150 | °C | – |
| 3.1.7 | ESD capability of power stage output and V_S pins | V_{ESD} | – | 4 | kV | Human Body Model according to ANSI EOS\ESD S5.1 standard (eqv. to MIL STD 883D and JEDEC JESD22-A114) |
| 3.1.8 | ESD capability of logic pins and ISO pin | V_{ESD} | – | 2 | kV | |

Note: Stresses above the ones listed here may cause permanent damage to the device. Exposure to absolute maximum rating conditions for extended periods may affect device reliability.

Note: Integrated protection functions are designed to prevent IC destruction under fault conditions described in the data sheet. Fault conditions are considered as “outside” normal operating range. Protection functions are not designed for continuous repetitive operation.

3.2 Operating Range

| Pos. | Parameter | Symbol | Limit Values | | Unit | Remarks |
|-------|----------------------|-----------|--------------|------|------|--------------------------------|
| | | | min. | max. | | |
| 3.2.1 | Supply voltage | V_S | 5 | 40 | V | Including over-voltage lockout |
| 3.2.2 | Supply voltage | V_S | 5 | 20 | V | Functional |
| 3.2.3 | Supply voltage | V_S | 8 | 20 | V | Parameter Specification |
| 3.2.4 | Logic supply voltage | V_{CC} | 4.75 | 5.5 | V | – |
| 3.2.5 | SPI clock frequency | f_{CLK} | – | 2 | MHz | – |
| 3.2.6 | Junction temperature | T_j | -40 | 150 | °C | – |

Note: Within the functional range the IC operates as described in the circuit description. The electrical characteristics are specified within the limit given at the table.

3.3 Thermal Resistance

| Pos. | Parameter | Symbol | Limit Values | | Unit | Conditions |
|-------|------------------|------------|--------------|------|------|-------------------|
| | | | min. | max. | | |
| 3.3.1 | Junction pin | R_{thjC} | – | 1.5 | K/W | – |
| 3.3.2 | Junction ambient | R_{thjA} | – | 50 | K/W | minimal footprint |

4 Block Description and Electrical Characteristics

4.1 Power Supply

4.1.1 General

The TLE 8201R has two power supply inputs: All power drivers are connected to the supply voltage V_S which is connected to the automotive 12 V board-net. The internal logic part is supplied by a separate Voltage $V_{CC} = 5 V$.

The advantage of this system is that information stored in the logic remains intact in the event of short-term failures in the supply voltage V_S . The system can therefore continue to operate after V_S has recovered, without having to be reprogrammed.

A rising edge on V_{CC} triggers an internal Power-On Reset (POR) to initialize the IC at power-on. All data stored internally is deleted, and the outputs are switched to high-impedance status (tristate).

4.1.2 Sleep-Mode

The TLE 8201R can be put in a low current-consumption mode by setting the input INH to LOW. The INH pin has an internal pull-down current source. In sleep-mode, all output transistors are turned off and the SPI is not operating. When enabling the IC by setting INH from L to H, a Power-On Reset is performed as described above.

4.1.3 Reverse Polarity

The TLE 8201R requires an external reverse polarity protection. The gate-driver (charge-pump output) for an external n-channel logic-level MOS-FET is integrated. The gate voltage is provided at pin GO which should be connected as shown in the application diagram.

4.1.4 Electrical Characteristics

Electrical Characteristics

$8 V < V_S < 20 V$; $4.75 V < V_{CC} < 5.25 V$; INH = High; all outputs open;
 $-40\text{ }^\circ\text{C} < T_j < 150\text{ }^\circ\text{C}$; unless otherwise specified

| Pos. | Parameter | Sym- bol | Limit Values | | | Unit | Conditions |
|------|-----------|-------------|--------------|------|------|------|------------|
| | | | min. | typ. | max. | | |

Current Consumption

| | | | | | | | |
|-------|----------------------|----------|---|-----|-----|----|----------------|
| 4.1.1 | Supply current | I_S | – | 3.0 | 7.0 | mA | – |
| 4.1.2 | Logic supply current | I_{CC} | – | 5 | 10 | mA | SPI not active |

Block Description and Electrical Characteristics
Electrical Characteristics

8 V < V_S < 20 V; 4.75 V < V_{CC} < 5.25 V; INH = High; all outputs open;
 -40 °C < T_j < 150 °C; unless otherwise specified

| Pos. | Parameter | Sym- bol | Limit Values | | | Unit | Conditions |
|-------|-------------------------|----------------|--------------|------|------|------|--|
| | | | min. | typ. | max. | | |
| 4.1.3 | Quiescent current | I_S | – | 2.5 | 5 | μA | INH = L, $V_S = 14$ V, $V_{OUT7-11} = 0$ V; $T_j < 85$ °C |
| 4.1.4 | Logic quiescent current | I_{CC} | – | 0.2 | 1 | μA | |
| 4.1.5 | Total quiescent current | $I_S + I_{CC}$ | – | 3 | 6 | μA | |

Charge Pump-output for Reverse-Polarity Protection FET (GO)

| | | | | | | | |
|-------|-------------------------|----------------|---|---|---|----|---------------------------------|
| 4.1.6 | Gate-Voltage | $V_{GO} - V_S$ | 5 | – | 8 | V | $I_{GO} = 50$ μA |
| 4.1.7 | Setup-time | t_{GO} | – | – | 1 | ms | – |
| 4.1.8 | Reverse leakage current | I_{lkGO} | – | – | 5 | μA | $V_S = 0$ V $V_{GO} = -14$ V |

4.2 Monitoring Functions

4.2.1 Power Supply Monitoring

The power supply Voltage V_S is monitored for over- and under voltage.

- **Under Voltage**

If the supply voltage V_S drops below the switch off voltage $V_{UV\ OFF}$, all output transistors are switched off and the power supply fail bit PSF is set. The error is not latched, i.e. if V_S rises again and reaches the switch on voltage $V_{UV\ ON}$, the power stages are restarted and the error bit is reset.

- **Over Voltage**

If the supply voltage V_S rises above the switch off voltage $V_{OV\ OFF}$, all output transistors are switched off and the power supply fail bit (bit 7 of the SPI diagnosis word) is set. The error is not latched, i.e. if V_S falls again and reaches the switch on voltage $V_{OV\ ON}$, the power stages are restarted and the error is reset.

4.2.1.1 Characteristics Power Supply Monitoring

Electrical Characteristics

$8\text{ V} < V_S < 20\text{ V}$; $4.75\text{ V} < V_{CC} < 5.25\text{ V}$; INH = High; all outputs open; $-40\text{ °C} < T_j < 150\text{ °C}$; unless otherwise specified

| Pos. | Parameter | Symbol | Limit Values | | | Unit | Conditions |
|-------|-----------------------|---------------|--------------|------|------|------|--------------------------|
| | | | min. | typ. | max. | | |
| 4.2.1 | UV-Switch-ON voltage | V_{UVON} | – | – | 5.2 | V | V_S increasing |
| 4.2.2 | UV-Switch-OFF voltage | V_{UVOFF} | 4.0 | – | 5.0 | V | V_S decreasing |
| 4.2.3 | UV-ON/OFF-Hysteresis | V_{UVHY} | – | 0.25 | – | V | $V_{UVON} - V_{UVOFF}$ |
| 4.2.4 | OV-Switch-OFF voltage | $V_{OV\ OFF}$ | 21 | – | 25 | V | V_S increasing |
| 4.2.5 | OV-Switch-ON voltage | V_{OVON} | 20 | – | 24 | V | V_S decreasing |
| 4.2.6 | OV-ON/OFF-Hysteresis | V_{OVHY} | 0.5 | 1 | – | V | $V_{OV\ OFF} - V_{OVON}$ |

4.2.2 Temperature Monitoring

Temperature sensors are integrated in the power stages. The temperature monitoring circuit compares the measured temperature to the warning and shutdown thresholds. If one or more temperature sensors reach the warning temperature, the temperature warning bit TW is set to HIGH. This bit is not latched (i.e. if the temperature falls below the warning threshold (with hysteresis), the TW bit is reset to LOW again).

If one or more temperature sensors reach the shut-down temperature, the outputs are shut down as described in the next paragraph and the temperature shut-down bit TSD is set to HIGH. The shutdown is latched (i.e. the output stages remain off and the TSD bit set high until a SRR command is sent or a power-on reset is performed).

The power-stages are subdivided into two groups for over-temperature shut-down:

- **Group1:** OUT 1, OUT 2 and OUT 3
- **Group2:** OUT 4 to 11

If one or more temperature sensors within a group reaches the shutdown threshold, all outputs within the group are switched off, while the other outputs continue normal operation.

4.2.2.1 Characteristics Temperature Monitoring

Electrical Characteristics

$8\text{ V} < V_S < 20\text{ V}$; $4.75\text{ V} < V_{CC} < 5.25\text{ V}$; INH = High; all outputs open;
 $-40\text{ }^\circ\text{C} < T_j < 150\text{ }^\circ\text{C}$; unless otherwise specified

| Pos. | Parameter | Symbol | Limit Values | | | Unit | Conditions |
|--------|--|--------------------|--------------|------|------|------|------------|
| | | | min. | typ. | max. | | |
| 4.2.7 | Thermal warning junction temperature ¹⁾ | T_{jW} | 120 | 145 | 170 | °C | – |
| 4.2.8 | Temperature warning hysteresis ¹⁾ | ΔT | – | 30 | – | K | – |
| 4.2.9 | Thermal shutdown junction temperature ¹⁾ | T_{jSD} | 150 | 175 | 200 | °C | – |
| 4.2.10 | Thermal switch-on junction temperature ¹⁾ | T_{jSO} | 120 | – | 170 | °C | – |
| 4.2.11 | Temperature shutdown hysteresis ¹⁾ | ΔT | – | 30 | – | K | – |
| 4.2.12 | Ratio of SD to W temperature ¹⁾ | T_{jSD} / T_{jW} | 1.05 | 1.20 | – | – | – |

¹⁾ Not subject to production test, specified by design

4.2.3 Current Sense

A current proportional to the output current that flows from the selected power output to GND is provided at the ISO (I sense out) pin. The output selection is done via the SPI. The sense current can be transformed into a voltage by an external sense resistor and provided to an A/D converter input (see section application).

4.2.3.1 Characteristics Current Sense

Electrical Characteristics

$8\text{ V} < V_S < 20\text{ V}$; $4.75\text{ V} < V_{CC} < 5.25\text{ V}$; INH = High; all outputs open;
 $-40\text{ }^\circ\text{C} < T_j < 150\text{ }^\circ\text{C}$; unless otherwise specified

| Pos. | Parameter | Symbol | Limit Values | | | Unit | Conditions |
|--|-----------------------------|---------------------|--------------|------|------|------|---|
| | | | min. | typ. | max. | | |
| HS1, HS2 (Register IS = 000, 001) | | | | | | | |
| 4.2.13 | Output voltage range | V_{ISO12} | 0 | – | 3 | V | $V_{CC} = 5\text{ V}$ |
| 4.2.14 | Current Sense Ratio | k_{ILIS12} | – | 2000 | – | – | $k_{ILIS} = I_{OUT}/I_{ISO}$ $I_{OUT} > 3\text{ A}$ |
| 4.2.15 | Current Sense accuracy | $k_{ILISacc12}$ | – | – | 10 | % | |
| 4.2.16 | Matching | Δk_{ILIS12} | -6 | 1 | 2 | % | $\Delta k_{ILIS12} = (k_{ILIS1} - k_{ILIS2}) / k_{ILIS1}$ |
| HS3, HS4 (Register IS = 010, 011) | | | | | | | |
| 4.2.17 | Output voltage range | V_{ISO34} | 0 | – | 3 | V | $V_{CC} = 5\text{ V}$ |
| 4.2.18 | Current Sense Ratio | k_{ILIS34} | – | 1000 | – | – | $k_{ILIS} = I_{OUT}/I_{ISO}$ $I_{OUT} > 1.5\text{ A}$ |
| 4.2.19 | Current Sense accuracy | $k_{ILISacc}$ | – | – | 10 | % | |
| HS7 (Register IS = 100) | | | | | | | |
| 4.2.20 | Output voltage range | V_{ISO7} | 0 | – | 3 | V | $V_{CC} = 5\text{ V}$ |
| 4.2.21 | Current Sense Ratio for HS7 | k_{ILIS7} | – | 2000 | – | – | $k_{ILIS} = I_{OUT}/I_{ISO}$ $I_{OUT} > 2\text{ A}$ |
| 4.2.22 | Current Sense accuracy | $k_{ILISacc}$ | – | – | 10 | % | |

4.3 SPI

4.3.1 General

The SPI is used for bidirectional communication with a control unit. The TLE 8201R acts as SPI-slave and the control unit acts as SPI-master. The 16-bit control word is read via the DI serial data input. The status word appears synchronously at the DO serial data output. The communication is synchronized by the serial clock input CLK.

Standard data transfer timing is shown in **Figure 3**. The clock polarity is data valid on falling edge. CLK must be low during CSN transition. The transfer is MSB first.

The transmission cycle begins when the chip is selected with the chip-select-not (CSN) input (H to L). Then the data is clocked through the shift register. The transmission ends when the CSN input changes from L to H and the word which has been read into the shift register becomes the control word. The DO output switches then to tristate status, thereby releasing the DO bus circuit for other uses. The SPI allows to parallel multiple SPI devices by using multiple CSN lines. The SPI can also be used with other SPI-devices in a daisy-chain configuration.

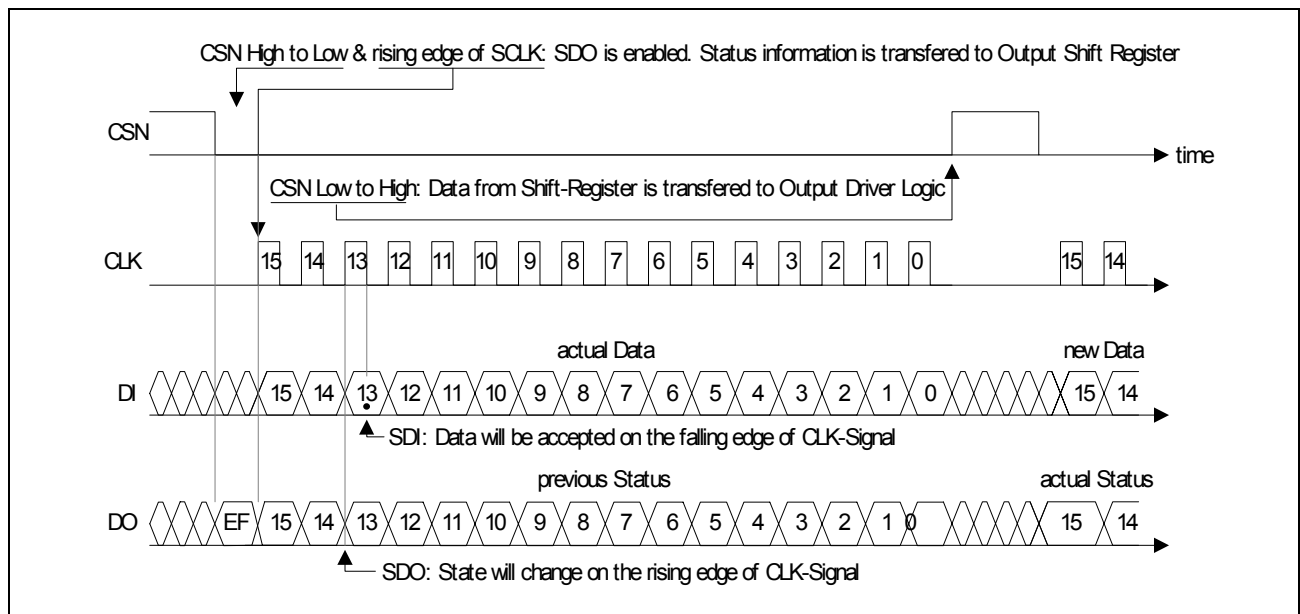

Figure 3 SPI standard data transfer timing

4.3.2 Register Address

The 16-bit SPI frame is composed of an addressable block, an address-independent block and a 2-bit address as shown in **Figure 4**.

The control word transmitted from the master to the TLE 7201R is executed at the end of the SPI transmission (CSN L -> H) and remains valid until a different control word is transmitted or a power on reset occurs. At the beginning of the SPI transmission (CSN

H ->L), the diagnostic data currently valid are latched into the SPI and transferred to the master. For Status Register address handling, please refer to [Section 4.3.4](#)

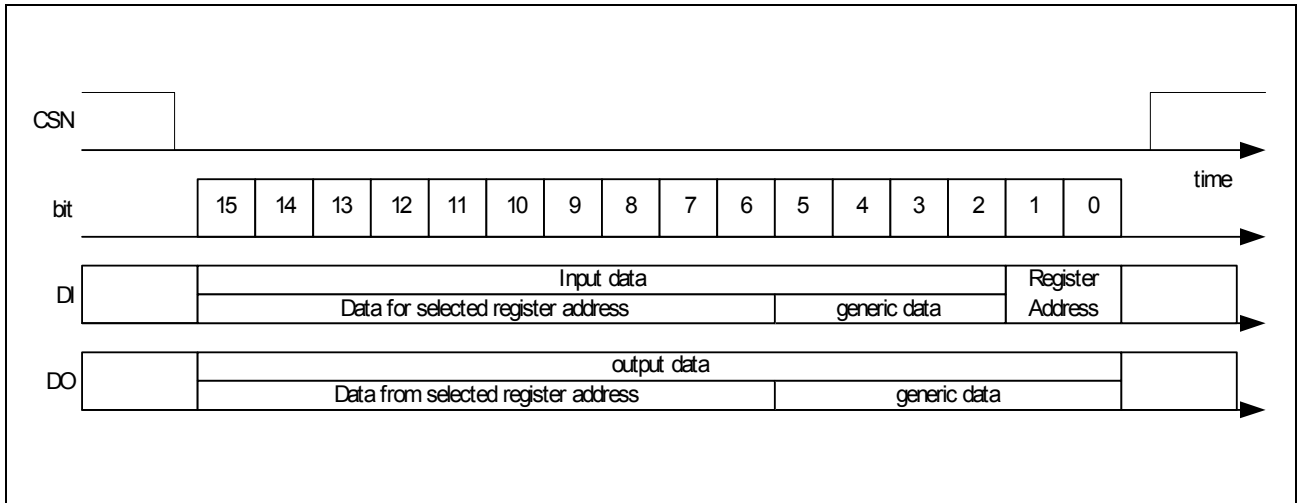

Figure 4 SPI structure

4.3.3 SPI bit definitions

4.3.3.1 Control - word

Table 1 Input (Control) Data Register

| Bit | CtrlReg 00 Lock and Mirror heat control | CtrlReg 01 PWM1 input select | CtrlReg 10 Mirror and Lamp- driver control | CtrlReg 11 PWM2 input select |
|-----------------------------------|---|------------------------------------|--|------------------------------------|
| 15 | LS1ON | HS7sel1 | LS4ON | HS7sel2 |
| 14 | HS1ON | HS8sel1 | HS4ON | HS8sel2 |
| 13 | LS2ON | HS9sel1 | LS5ON | HS9sel2 |
| 12 | HS2ON | HS10sel1 | HS5ON | HS10sel2 |
| 11 | LS3ON | HS11sel1 | LS6ON | HS11sel2 |
| 10 | HS3ON | LS1sel1 | HS6ON | LS1sel2 |
| 9 | HS7ON | LS2sel1 | HS8ON | LS2sel2 |
| 8 | Testmode | LS3sel1 | HS9ON | LS3sel2 |
| 7 | Testmode | OpL7ON | HS10ON | OpL89ON |
| 6 | Testmode | Testmode | HS11ON | OpL1011ON |
| Address - independent data | | | | |
| 5 | IS_2 | IS_2 | IS_2 | IS_2 |
| 4 | IS_1 | IS_1 | IS_1 | IS_1 |
| 3 | IS_0 | IS_0 | IS_0 | IS_0 |
| 2 | SRR | SRR | SRR | SRR |
| Address - bits | | | | |
| 1 | RA_1 = 0 | RA_1 = 0 | RA_1 = 1 | RA_1 = 1 |
| 0 | RA_0 = 0 | RA_0 = 1 | RA_0 = 0 | RA_0 = 1 |

Note: Testmode-bits must be set to L for normal operation

Table 2 Control bit definitions

| Control Bit | Definition | | | | | | | | | | | | | | | | | | | | | | | | | | | | |
|------------------|---|------|--------------------------------------|--|--|---|---|---|-----|---|---|---|-----|---|---|---|-----|---|---|---|-----|---|---|---|-----|------------|--|--|--------------------------------------|
| LSxON | low-side switch no. x is turned ON (OFF) if this bit is set to HIGH (LOW) | | | | | | | | | | | | | | | | | | | | | | | | | | | | |
| HSxON | high-side switch no. x is turned ON (OFF) if this bit is set to HIGH (LOW) | | | | | | | | | | | | | | | | | | | | | | | | | | | | |
| xsel1 | power switch x is selected to be switched by the PWM1 input. | | | | | | | | | | | | | | | | | | | | | | | | | | | | |
| xsel2 | power switch x is selected to be switched by the PWM2 input | | | | | | | | | | | | | | | | | | | | | | | | | | | | |
| OpL7ON | the pull-up current for open-load detection on output 7 is switched on (off) if this bit is set to HIGH (LOW) | | | | | | | | | | | | | | | | | | | | | | | | | | | | |
| OpL89ON | the pull-up currents for open-load detection on outputs 8 and 9 are switched on (off) if this bit is set to HIGH (LOW) | | | | | | | | | | | | | | | | | | | | | | | | | | | | |
| OpL1011ON | the pull-up currents for open-load detection on outputs 10 and 11 are switched on (off) if this bit is set to HIGH (LOW) | | | | | | | | | | | | | | | | | | | | | | | | | | | | |
| IS_x | the output for the current sense multiplexer is selected by these bits: | | | | | | | | | | | | | | | | | | | | | | | | | | | | |
| | <table border="1"> <thead> <tr> <th>IS_2</th> <th>IS_1</th> <th>IS_0</th> <th>Power stage selected for current sense</th> </tr> </thead> <tbody> <tr> <td>0</td> <td>0</td> <td>0</td> <td>HS1</td> </tr> <tr> <td>0</td> <td>0</td> <td>1</td> <td>HS2</td> </tr> <tr> <td>0</td> <td>1</td> <td>0</td> <td>HS3</td> </tr> <tr> <td>0</td> <td>1</td> <td>1</td> <td>HS4</td> </tr> <tr> <td>1</td> <td>0</td> <td>0</td> <td>HS7</td> </tr> <tr> <td colspan="3">all others</td> <td>no output selected ($I_{ISO} = 0$)</td> </tr> </tbody> </table> | IS_2 | IS_1 | IS_0 | Power stage selected for current sense | 0 | 0 | 0 | HS1 | 0 | 0 | 1 | HS2 | 0 | 1 | 0 | HS3 | 0 | 1 | 1 | HS4 | 1 | 0 | 0 | HS7 | all others | | | no output selected ($I_{ISO} = 0$) |
| | IS_2 | IS_1 | IS_0 | Power stage selected for current sense | | | | | | | | | | | | | | | | | | | | | | | | | |
| | 0 | 0 | 0 | HS1 | | | | | | | | | | | | | | | | | | | | | | | | | |
| | 0 | 0 | 1 | HS2 | | | | | | | | | | | | | | | | | | | | | | | | | |
| | 0 | 1 | 0 | HS3 | | | | | | | | | | | | | | | | | | | | | | | | | |
| | 0 | 1 | 1 | HS4 | | | | | | | | | | | | | | | | | | | | | | | | | |
| | 1 | 0 | 0 | HS7 | | | | | | | | | | | | | | | | | | | | | | | | | |
| all others | | | no output selected ($I_{ISO} = 0$) | | | | | | | | | | | | | | | | | | | | | | | | | | |
| | | | | | | | | | | | | | | | | | | | | | | | | | | | | | |
| | | | | | | | | | | | | | | | | | | | | | | | | | | | | | |
| | | | | | | | | | | | | | | | | | | | | | | | | | | | | | |
| | | | | | | | | | | | | | | | | | | | | | | | | | | | | | |
| | | | | | | | | | | | | | | | | | | | | | | | | | | | | | |
| SRR | Status Register Reset. If set to high, the error bits of the selected status register are reset after transmission of the data in the next SPI frame (see <Fett>Section 4.3.4) | | | | | | | | | | | | | | | | | | | | | | | | | | | | |
| RA_x | Register Address, selects the control-register address for the current SPI transmission and the status-register address for the next SPI transmission | | | | | | | | | | | | | | | | | | | | | | | | | | | | |

4.3.3.2 Diagnosis

Table 3 Output (Status) Data Register

| Bit | StatReg 00 Lock and Mirror heat overload | StatReg 01 Lock and Mirror heat open load | StatReg 10 Mirror and Lamp- driver overload | StatReg 11 Mirror and Lamp- driver open load |
|-----------------------------------|--|---|---|--|
| | valid for input data RA = 00 | valid for input data RA = 01 | valid for input data RA = 10 | valid for input data RA = 11 |
| 15 | LS1OvL | LS1OpL | LS4OvL | LS4OpL |
| 14 | HS1OvL | n.c. | HS4OvL | n.c. |
| 13 | LS2OvL | LS2OpL | LS5OvL | LS5OpL |
| 12 | HS2OvL | n.c. | HS5OvL | n.c. |
| 11 | LS3OvL | LS3OpL | LS6OvL | LS6OpL |
| 10 | HS3OvL | n.c. | HS6OvL | n.c. |
| 9 | HS7OvL | HS7OpL | HS8OvL | HS8OpL |
| 8 | n.c. | n.c. | HS9OvL | HS9OpL |
| 7 | n.c. | n.c. | HS10OvL | HS10OpL |
| 6 | n.c. | n.c. | HS11OvL | HS11OpL |
| Address - independent data | | | | |
| 5 | PSF | PSF | PSF | PSF |
| 4 | TSD | TSD | TSD | TSD |
| 3 | TW | TW | TW | TW |
| Error Flags | | | | |
| 2 | EF_11 | EF_11 | EF_11 | EF_10 |
| 1 | EF_10 | EF_10 | EF_01 | EF_01 |
| 0 | EF_01 | EF_00 | EF_00 | EF_00 |

Note: n.c. bits are fixed LOW

Table 4 Status bit definitions

| Status Bit | Definition |
|-------------------|--|
| LSxOvL | Low-Side switch Over Load. Set to HIGH if low-side switch no. x is shut down due to overcurrent or over temperature |
| HSxOvL | High-Side switch Over Load. Set to HIGH if high-side switch no. x is shut down due to overcurrent or over temperature |
| LSxOpL | Low-Side switch open load. Set to HIGH if open load (undercurrent) is detected in low-side switch x |
| HSxOpL | High-Side switch Open Load. Set to HIGH if open load is detected in high-side switch x |
| PSF | Power Supply Fail. Set to HIGH if the Voltage at the Vs pin is below the Vs under-voltage threshold or above the Vs over-voltage threshold |
| TSD | one or more powerstages are shut down due to over temperature |
| TW | one or more powerstages have reached the warning temperature |
| EF_xy | Error Flag for StatReg xy. Set to HIGH if any bit is set to HIGH StatReg xy |
| n.c. | not connected. These bits may be used for test-mode purposes. They are set to fixed LOW in normal operation |

4.3.4 Status Register Address selection and Reset

The SPI is using a standard shift-register concept with daisy-chain capability. Any data transmitted to the SPI will be available to the internal logic part at the end of the SPI transmission (CSN L -> H). To read a specific register, the address of the register is sent by the master to the SPI in a first SPI frame. The data that corresponds to this address is transmitted by the SPI DO during the following (second) SPI frame to the master. The default address for Status Register transmission after Power-ON Reset is 00.

The Status-Register-Reset command-bit is executed after the next SPI transmission. The three bits RA_0, RA_1 and SRR act as command to read and reset (or not reset) the addressed Status-Register. This is also explained in [Figure 5](#).

The TSD status bit is not part of the addressable data but of the address independent data. When any of the status registers is reset, the TSD bit is reset, too.

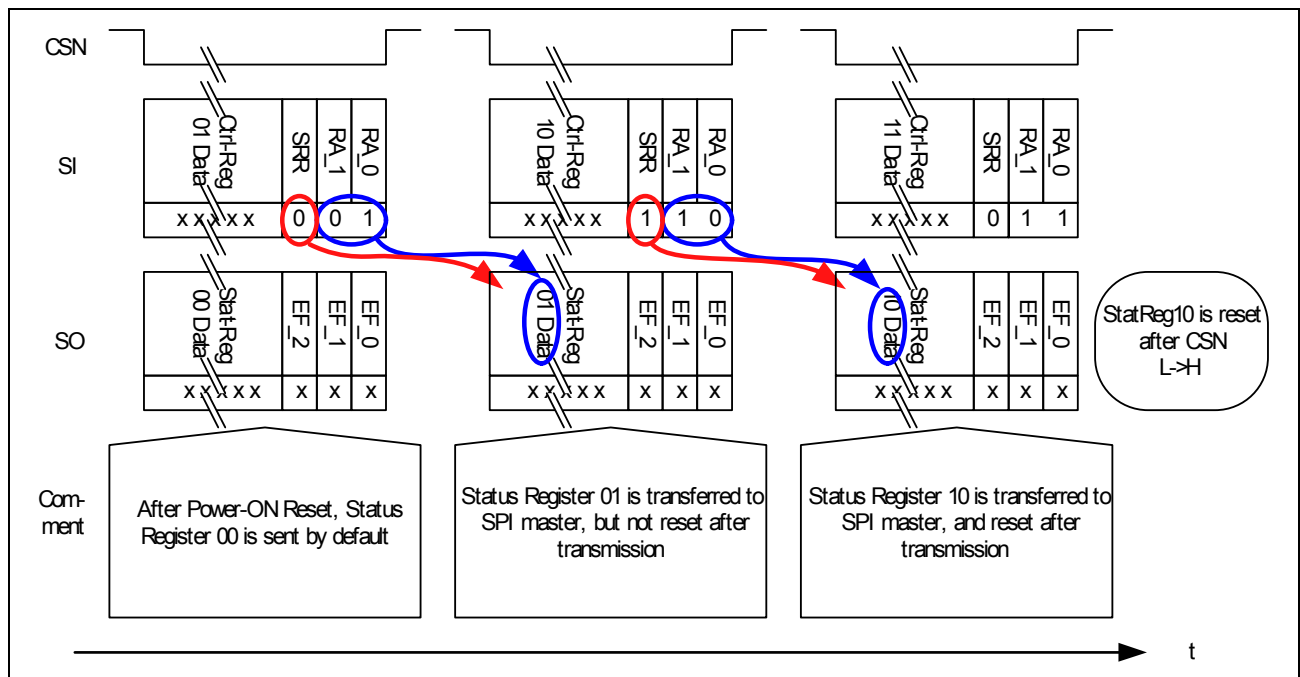

Figure 5 Status Register Addressing and Reset

4.3.4.1 Error-Flag

In addition to the 16 bits transferred from the TLE 7201R to the SPI master, an additional Error Flag (EF) is transmitted at the DO pin. The EF status is shown on the DO pin after CSN H->L, before the first rising edge at CLK, as shown in **Figure 6**.

The Error flag is set to H if any of the Status Registers contains an error message (i.e. EF = EF_00 or EF_01 or EF_10 or EF_11)

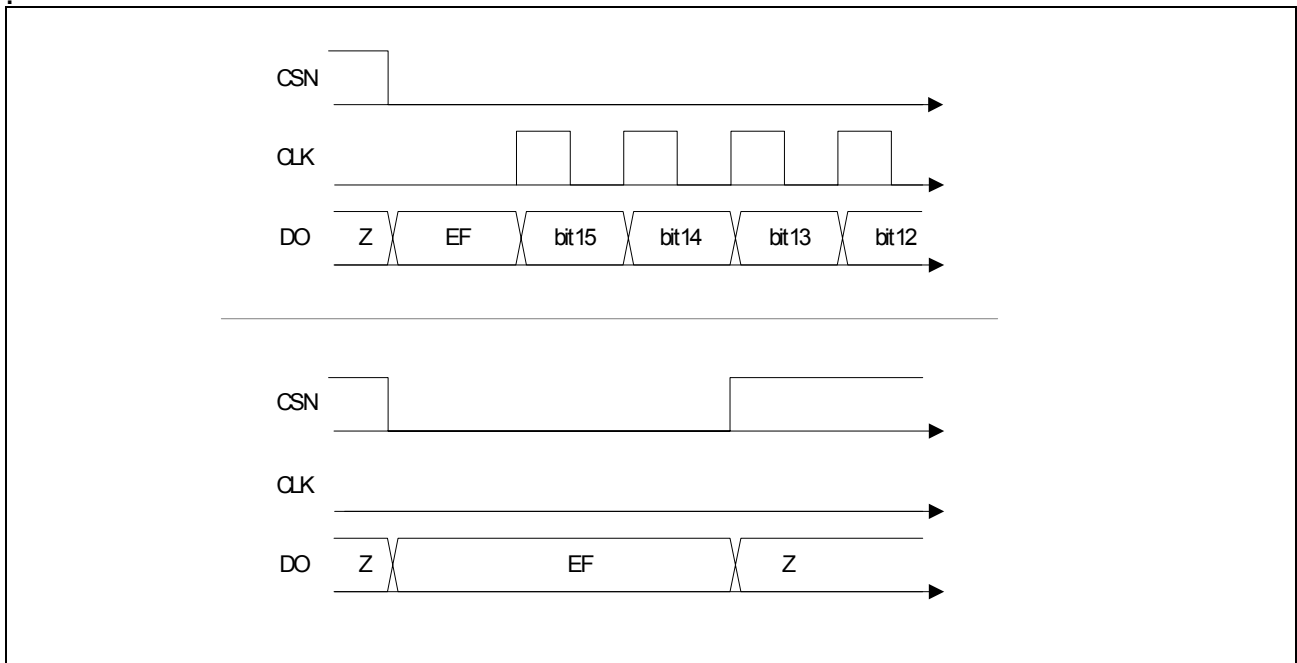

Figure 6 Error Flag transmission on DO during standard SPI transmission (top), or without additional SPI transmission, CLK low (bottom)

4.3.5 Electrical Characteristics

Electrical Characteristics - SPI-timing

8 V < V_S < 20 V; 4.75 V < V_{CC} < 5.25 V; INH = High; all outputs open; -40 °C < T_j < 150 °C; unless otherwise specified

| Pos. | Parameter | Symbol | Limit Values | | | Unit | Conditions |
|-------|--------------------------------|------------|--------------|------|------|------|-----------------|
| | | | min. | typ. | max. | | |
| 4.3.1 | CSN lead time | t_{lead} | 100 | – | – | ns | 1 ¹⁾ |
| 4.3.2 | CSN lag time | t_{lag} | 100 | – | – | ns | 2 ¹⁾ |
| 4.3.3 | Fall time for CSN, CLK, DI, DO | t_f | – | – | 25 | ns | 3 ¹⁾ |
| 4.3.4 | Rise time for CSN, CLK, DI, DO | t_r | – | – | 25 | ns | 4 ¹⁾ |

Electrical Characteristics - SPI-timing

8 V < V_S < 20 V; 4.75 V < V_{CC} < 5.25 V; INH = High; all outputs open;
 -40 °C < T_j < 150 °C; unless otherwise specified

| Pos. | Parameter | Sym- bol | Limit Values | | | Unit | Conditions |
|--------|-------------------------------------|---------------|--------------|------|------|------|-----------------------|
| | | | min. | typ. | max. | | |
| 4.3.5 | DI data setup time | t_{SU} | 40 | – | – | ns | 5 ¹⁾ |
| 4.3.6 | DI data hold time | t_h | 40 | – | – | ns | 6 ¹⁾ |
| 4.3.7 | DI data valid time | t_v | – | – | 50 | ns | – ¹⁾ |
| 4.3.8 | DO data setup time | $t_{DOsetup}$ | 0 | – | 60 | ns | 7 and 8 ¹⁾ |
| 4.3.9 | DO data hold time | t_{DOhold} | 50 | – | – | ns | 9 ¹⁾ |
| 4.3.10 | No-data-time between SPI commands | t_{nodata} | 5 | – | – | µs | 10 ¹⁾ |
| 4.3.11 | Clock frequency | f_{CL} | – | – | 2 | MHz | 1) |
| 4.3.12 | Duty cycle of incoming clock at CLK | – | 40 | – | 60 | % | – ¹⁾ |

1) SPI Timing is not subject to production test - specified by design. SPI functional test is performed at 5 MHz CLK frequency. Timing specified with an external load of 30pF at pin [DO].

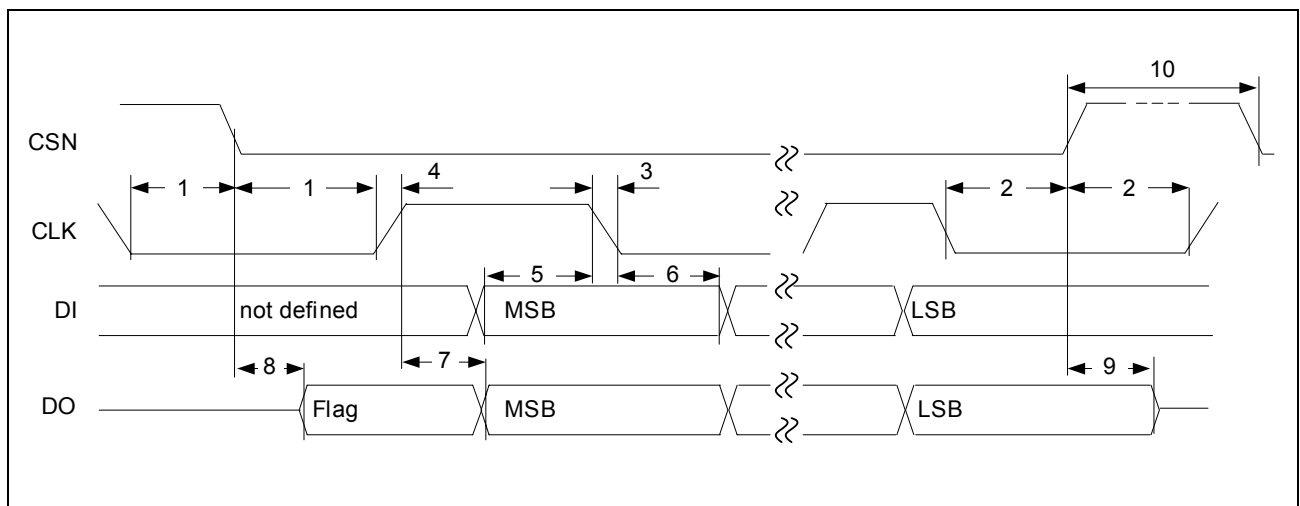

Figure 7 Timing Diagram

4.3.6 PWM inputs

The PWM inputs PWM1 and PWM2 are direct power stage control inputs that can be used to switch on and off one or more of the power transistors with a PWM signal supplied to this pin. The setting of the SPI Registers CtrlReg_01 and CtrlReg_11 defines which of the power stages will be controlled by the PWM inputs. If the selection-bits of

power Stage x, xsel1 and xsel2 are LOW, the power stage x is controlled only via the SPI control bit xON. If the selection bit xsel1 is HIGH and the control bit xON is also high, the power stage x is controlled by the PWM1 pin (xsel2 and PWM2, respectively). The behavior is shown in the principal schematic and truth table below. In terms of power dissipation due to switching loss, a PWM frequency below 200 Hz is recommended.

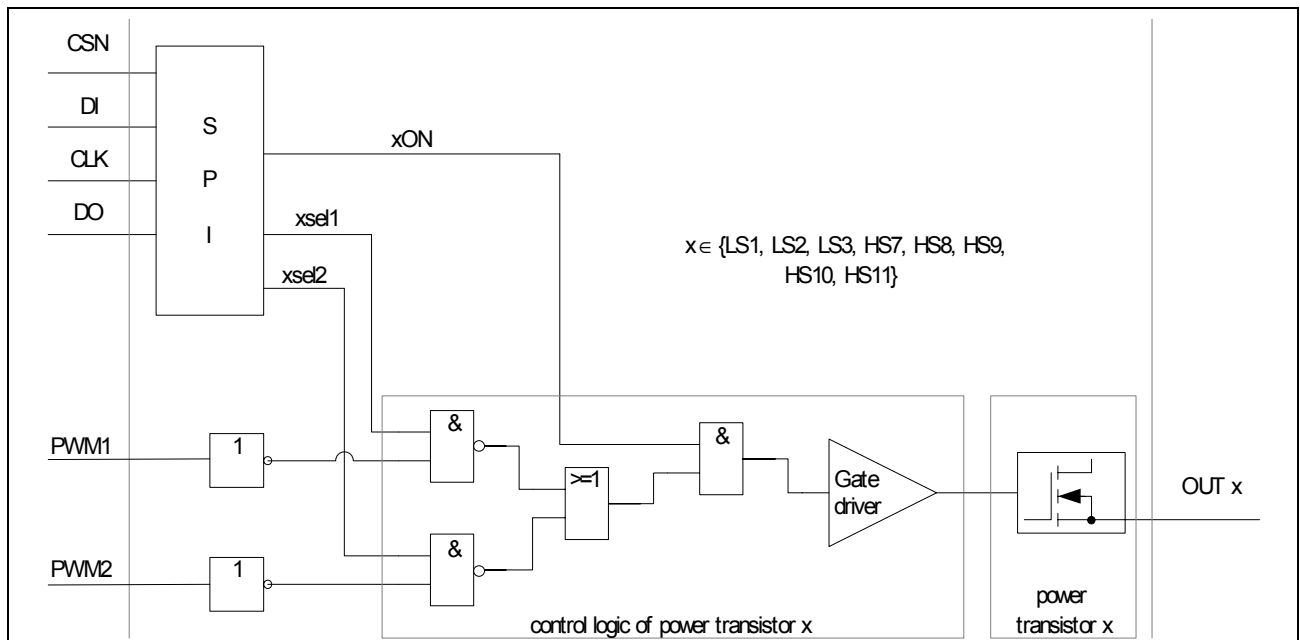

Figure 8 PWM input and SPI control registers

Truth-table for PWM inputs

| xON | xsel1 | xsel2 | PWM1 | PWM2 | power stage x |
|-----|-------|-------|------|------|---------------|
| 0 | x | x | x | x | OFF |
| 1 | 0 | 0 | x | x | ON |
| 1 | 1 | 0 | 0 | x | OFF |
| 1 | 1 | 0 | 1 | x | ON |
| 1 | 0 | 1 | x | 0 | OFF |
| 1 | 0 | 1 | x | 1 | ON |
| 1 | 1 | 1 | 1 | x | ON |
| 1 | 1 | 1 | x | 1 | ON |
| 1 | 1 | 1 | 0 | 0 | OFF |

4.4 Power-Outputs 1-6 (Bridge Outputs)

4.4.1 Protection and Diagnosis

4.4.1.1 Short Circuit of Output to Ground or Vs

The low-side switches are protected against short circuit to supply and the high-side switches against short to GND.

If a switch is turned on and the current rises above the shutdown threshold I_{SD} for longer than the shutdown delay time t_{dSD} , the output transistor is turned off and the corresponding diagnosis bit is set. During the delay time, the current is limited to I_{SC} as shown in [Figure 9](#).

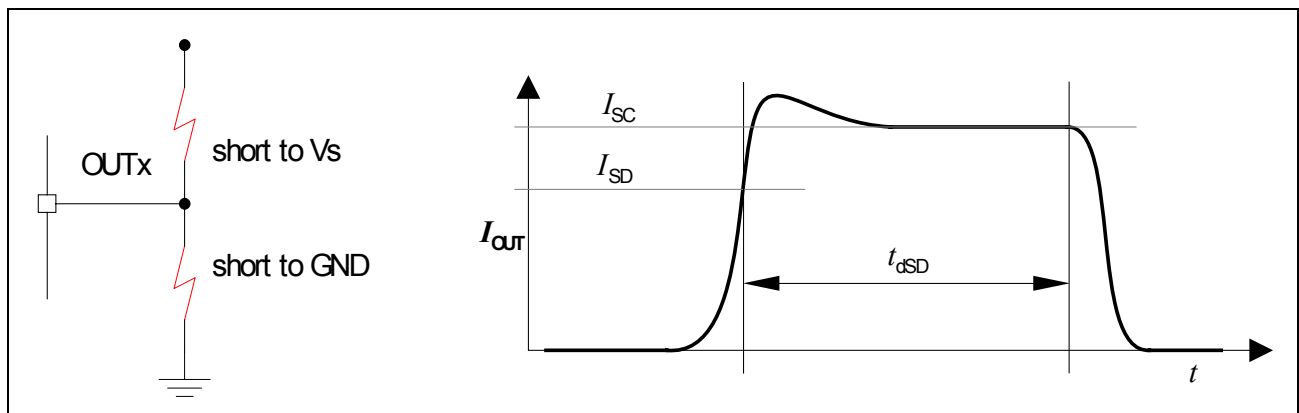

Figure 9 Short circuit protection

The delay time is relatively short (typ. 25 μ s) to limit the energy that is dissipated in the device during a short circuit. This scheme allows high peak-currents as required in motor-applications.

The output stage stays off and the error bit set until a status register reset is sent to the SPI or a power-on reset is performed.

4.4.1.2 Cross-Current

If for instance HS1 is ON and LS1 is OFF, you can turn OFF HS1 and turn ON LS1 with the same SPI command. To ensure that there is no overlap of the switching slopes that would lead to a cross current, the dead-time H to L and L to H is specified.

In the control registers, it is also possible to turn ON high- and low-side switches of the same half-bridge (e.g. LS1ON = H and HS1ON = H). To prevent a cross-current through the bridge, such a command is not executed. Instead, both switches are turned OFF and the Over-Load bit is set High for both switches (e.g. LS1OvL = H and HS1OvL = H).

4.4.1.3 Open Load

Open-load detection in ON-state is implemented in the low-side switches of the bridge outputs: When the current through the low side transistor is lower than the reference current I_{OCD} in ON-state for longer than the open-load detection delay time t_{dOC} , the according open-load diagnosis bit is set. The output transistor, however, remains ON. The open load error bit is latched and can be reset by the SPI status register reset or by a power-on reset.

As an example, if a motor is connected between outputs OUT 1 and OUT 2 with a broken wire as shown in **Figure 10**, the resulting diagnostic information is shown in **Table 5**

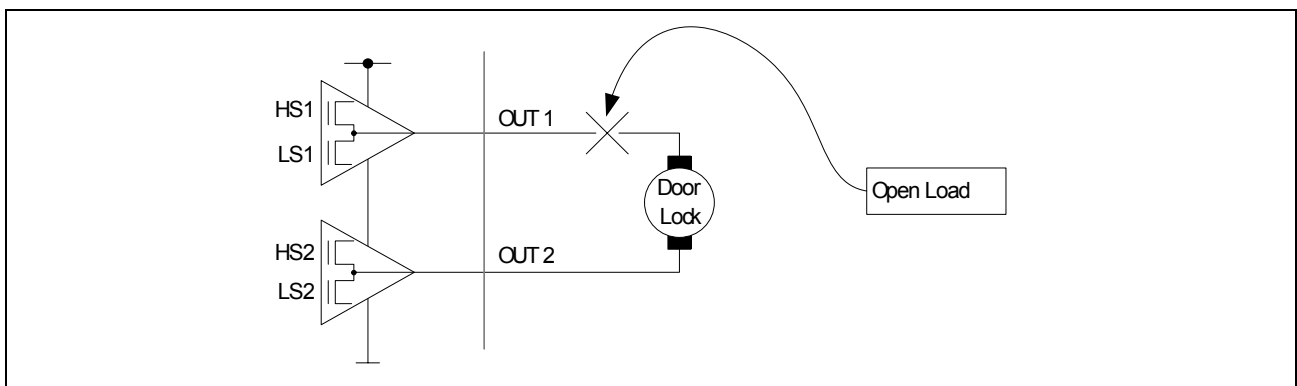

Figure 10 Open load example

Table 5 Open load diagnosis example

| Control | | | | | Diagnostic information | | | | Remark on Open Load Detection |
|---------|--------|--------|--------|--------------------|------------------------|----------|--------------------|----------|-------------------------------|
| | | | | | motor connected | | motor disconnected | | |
| LS1 ON | HS1 ON | LS2 ON | HS2 ON | motor rotation | LS1 OpL | LS2 OpL | LS1 OpL | LS2 OpL | |
| 0 | 0 | 0 | 0 | motor off | 0 | 0 | 0 | 0 | not detectable |
| 1 | 0 | 0 | 1 | clock-wise | 0 | 0 | 1 | 0 | detected |
| 0 | 1 | 1 | 0 | counter clock-wise | 0 | 0 | 0 | 1 | detected |
| 0 | 1 | 0 | 1 | brake high | 0 | 0 | 0 | 0 | not detectable |
| 1 | 0 | 1 | 0 | brake low | 1 | 1 | 1 | 1 | not detectable. |

4.4.2 Electrical Characteristics

Electrical Characteristics OUT 1 and 2 (driver for door latch)

8 V < V_S < 20 V; 4.75 V < V_{CC} < 5.25 V; INH = High; all outputs open;
 -40 °C < T_j < 150 °C; unless otherwise specified

| Pos. | Parameter | Symbol | Limit Values | | | Unit | Conditions |
|------|-----------|--------|--------------|------|------|------|------------|
| | | | min. | typ. | max. | | |

Static Drain-source ON-Resistance

| | | | | | | | |
|-------|---------------------------|--------------|---|---|-----|----|---|
| 4.4.1 | High- and low-side switch | R_{DSON12} | – | – | 150 | mΩ | $I_{OUT} = 3\text{ A};$ $T_j = 25\text{ °C}$ |
| | | | – | – | 260 | mΩ | $I_{OUT} = 3\text{ A}$ |

Switching Times

| | | | | | | | |
|-------|--------------------------|---------------|---|----|-----|----|--|
| 4.4.2 | high-side ON delay-time | t_{dONH12} | – | 50 | 100 | μs | $V_S = 14\text{ V},$ resistive load of 10 Ω, see Figure 11 and Figure 12 |
| 4.4.3 | high-side OFF delay time | $t_{dOFFH12}$ | – | 25 | 50 | μs | |
| 4.4.4 | low-side ON delay-time | t_{dONL12} | – | 50 | 100 | μs | |
| 4.4.5 | low-side OFF delay time | $t_{dOFFL12}$ | – | 25 | 50 | μs | |
| 4.4.6 | dead-time H to L | t_{DHL12} | 3 | – | – | μs | $t_{dONL12} -$ $t_{dOFFH12}$ |
| 4.4.7 | dead-time L to H | t_{DLH12} | 3 | – | – | μs | $t_{dONH12} -$ $t_{dOFFL12}$ |

Short Circuit Protection

| | | | | | | | |
|--------|-------------------------------------|-------------|----|----|----|----|--------------------|
| 4.4.8 | Over-current shutdown threshold | I_{SD12} | 8 | – | 15 | A | high- and low-side |
| 4.4.9 | Shutdown delay time | t_{dSD12} | 10 | 25 | 50 | μs | |
| 4.4.10 | Short circuit current ¹⁾ | I_{SC12} | – | 20 | – | A | |

Open Load Detection

| | | | | | | | |
|--------|-------------------|-------------|-----|-----|-----|----|----------|
| 4.4.11 | Detection current | I_{OCD12} | 40 | – | 200 | mA | low-side |
| 4.4.12 | Delay time | t_{dOC12} | 200 | 350 | 600 | μs | |

Leakage Current

| | | | | | | | |
|--------|--------------------------|----------|---|---|----|----|------------------------|
| 4.4.13 | OFF-state output current | I_{QL} | – | – | 25 | μA | $V_{OUT} = \text{GND}$ |
|--------|--------------------------|----------|---|---|----|----|------------------------|

¹⁾ Not subject to production test - specified by design

Electrical Characteristics OUT3, 4 (Driver for deadbolt, mirror fold and mirror xy)

8 V < V_S < 20 V; 4.75 V < V_{CC} < 5.25 V; INH = High; all outputs open;
 -40 °C < T_j < 150 °C; unless otherwise specified

| Pos. | Parameter | Symbol | Limit Values | | | Unit | Conditions |
|------|-----------|--------|--------------|------|------|------|------------|
| | | | min. | typ. | max. | | |

Static Drain-source ON-Resistance

| | | | | | | | |
|--------|---------------------------|--------------|---|---|-----|----------|---------------------------------------|
| 4.4.14 | High- and low-side switch | R_{DSON34} | – | – | 0.4 | Ω | $I_{OUT} = \pm 1$ A; $T_j = 25$ °C |
| | | | – | – | 0.7 | Ω | $I_{OUT} = \pm 1$ A |

Switching Times

| | | | | | | | |
|--------|--------------------------|---------------|---|----|-----|---------|---|
| 4.4.15 | high-side ON delay-time | t_{dONH34} | – | 50 | 100 | μ s | $V_S = 14$ V, resistive load of 14 Ω , see Figure 11 and Figure 12 |
| 4.4.16 | high-side OFF delay time | $t_{dOFFH34}$ | – | 25 | 50 | μ s | |
| 4.4.17 | low-side ON delay-time | t_{dONL34} | – | 50 | 100 | μ s | |
| 4.4.18 | low-side OFF delay time | $t_{dOFFL34}$ | – | 25 | 50 | μ s | |
| 4.4.19 | dead-time H to L | t_{DHL34} | 3 | – | – | μ s | t_{dONL34} - $t_{dOFFH34}$ |
| 4.4.20 | dead-time L to H | t_{DLH34} | 3 | – | – | μ s | t_{dONH34} - $t_{dOFFL34}$ |

Short Circuit Protection

| | | | | | | | |
|--------|-------------------------------------|-------------|----|----|----|---------|--------------------|
| 4.4.21 | Over-current shutdown threshold | I_{SD34} | 3 | 4 | 8 | A | high- and low-side |
| 4.4.22 | Shutdown delay time | t_{dSD34} | 10 | 25 | 50 | μ s | |
| 4.4.23 | Short Circuit current ¹⁾ | I_{SC34} | – | 6 | – | A | |

Open Load Detection

| | | | | | | | |
|--------|-------------------|-------------|-----|-----|-----|---------|----------|
| 4.4.24 | Detection current | I_{OCD34} | 12 | 25 | 40 | mA | low-side |
| 4.4.25 | Delay time | t_{dOC34} | 200 | 350 | 600 | μ s | |

Leakage Current

| | | | | | | | |
|--------|--------------------------|----------|---|---|----|---------|-------------------|
| 4.4.26 | OFF-state output current | I_{QL} | – | – | 10 | μ A | $V_{OUT} = 0.2$ V |
|--------|--------------------------|----------|---|---|----|---------|-------------------|

¹⁾ Not subject to production test - specified by design

**Electrical Characteristics OUT 5, 6
(driver for mirror x-y position)**

8 V < V_S < 20 V; 4.75 V < V_{CC} < 5.25 V; INH = High; all outputs open;
-40 °C < T_j < 150 °C; unless otherwise specified

| Pos. | Parameter | Symbol | Limit Values | | | Unit | Conditions |
|------|-----------|--------|--------------|------|------|------|------------|
| | | | min. | typ. | max. | | |

Static Drain-source ON-Resistance

| | | | | | | | |
|--------|---------------------------|--------------|---|---|-----|----------|---|
| 4.4.27 | High- and low-side switch | R_{DSON56} | – | – | 0.8 | Ω | $I_{OUT} = \pm 0.5$ A; $T_j = 25$ °C |
| | | | – | – | 1.3 | Ω | $I_{OUT} = \pm 0.5$ A |

Switching Times

| | | | | | | | |
|--------|--------------------------|---------------|---|----|-----|---------|---|
| 4.4.28 | high-side ON delay-time | t_{dONH56} | – | 50 | 100 | μ s | $V_S = 14$ V, resistive load of 25 Ω , see Figure 11 and Figure 12 |
| 4.4.29 | high-side OFF delay time | $t_{dOFFH56}$ | – | 25 | 50 | μ s | |
| 4.4.30 | low-side ON delay-time | t_{dONL56} | – | 50 | 100 | μ s | |
| 4.4.31 | low-side OFF delay time | $t_{dOFFL56}$ | – | 25 | 50 | μ s | |
| 4.4.32 | dead-time H to L | t_{DHL56} | 3 | – | – | μ s | t_{dONL56} - $t_{dOFFH56}$ |
| 4.4.33 | dead-time L to H | t_{DLH56} | 3 | – | – | μ s | t_{dONH56} - $t_{dOFFL56}$ |

Short Circuit Protection

| | | | | | | | |
|--------|-------------------------------------|-------------|------|-----|-----|---------|--------------------|
| 4.4.34 | Over-current shutdown threshold | I_{SD56} | 1.25 | 1.5 | 2.5 | A | high- and low-side |
| 4.4.35 | Shutdown delay time | t_{dSD56} | 10 | 25 | 50 | μ s | |
| 4.4.36 | Short Circuit current ¹⁾ | I_{SC56} | – | 3.0 | – | A | |

Open Load Detection

| | | | | | | | |
|--------|-------------------|-------------|-----|-----|-----|---------|----------|
| 4.4.37 | Detection current | I_{OCD56} | 12 | 25 | 40 | mA | low-side |
| 4.4.38 | Delay time | t_{dOC56} | 200 | 350 | 600 | μ s | |

Leakage Current

| | | | | | | | |
|--------|--------------------------|----------|---|---|----|---------|-------------------|
| 4.4.39 | OFF-state output current | I_{QL} | – | – | 10 | μ A | $V_{OUT} = 0.2$ V |
|--------|--------------------------|----------|---|---|----|---------|-------------------|

¹⁾ Not subject to production test - specified by design

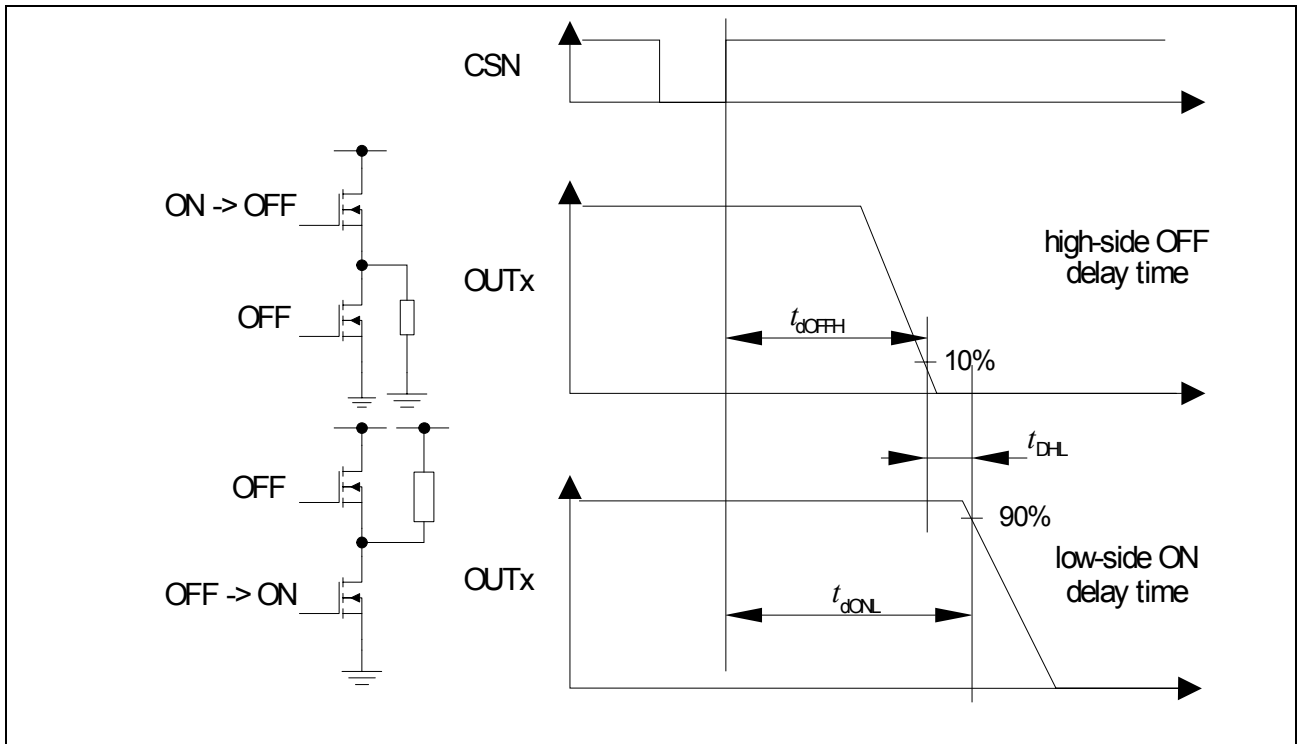

Figure 11 Timing bridge outputs high to low

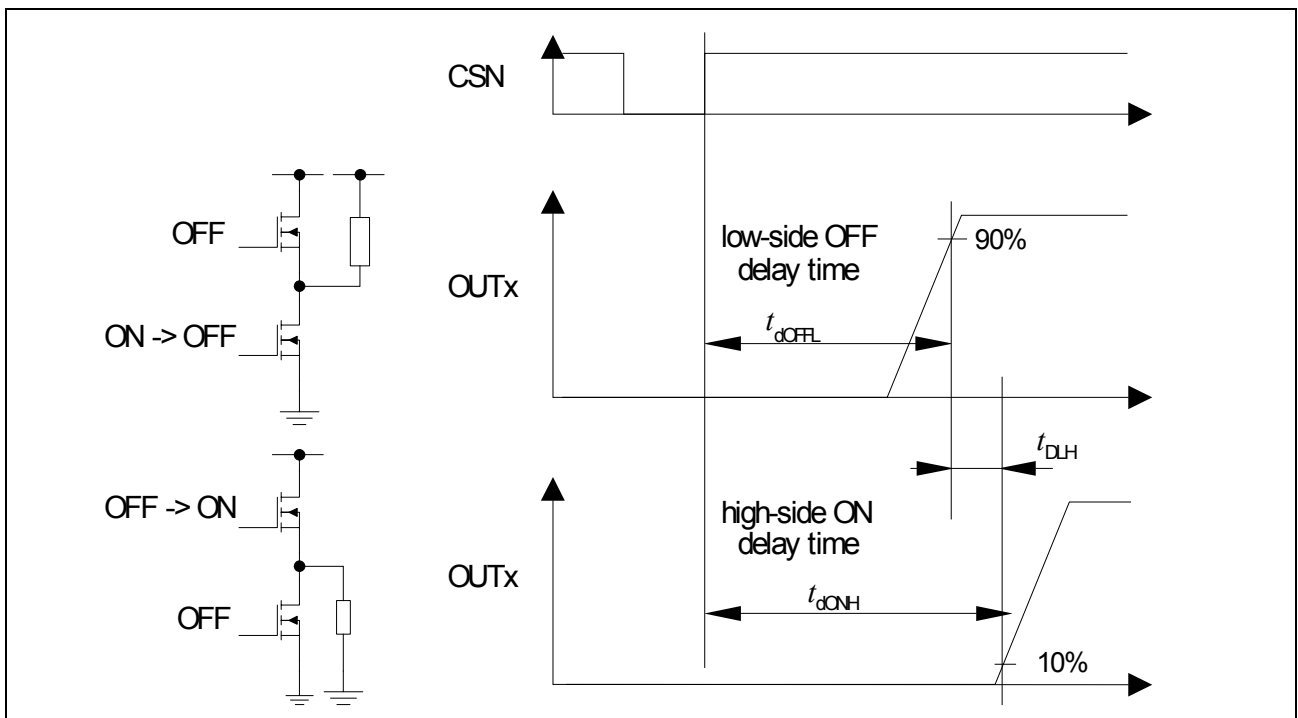

Figure 12 Timing bridge outputs low to high

4.5 Power-Output 7 (Mirror heater driver)

Output 7 is a high-side switch intended to drive ohmic loads like the heater of an exterior mirror.

4.5.1 Protection and Diagnosis

4.5.1.1 Short Circuit of Output to Ground

If the high-side switch is turned on and the current rises above the shutdown threshold I_{SD} for longer than the shutdown delay time t_{dSD} , the output transistor is turned off and the corresponding diagnosis bit is set. During the delay time, the current is limited to I_{SC} as shown in [Figure 13](#).

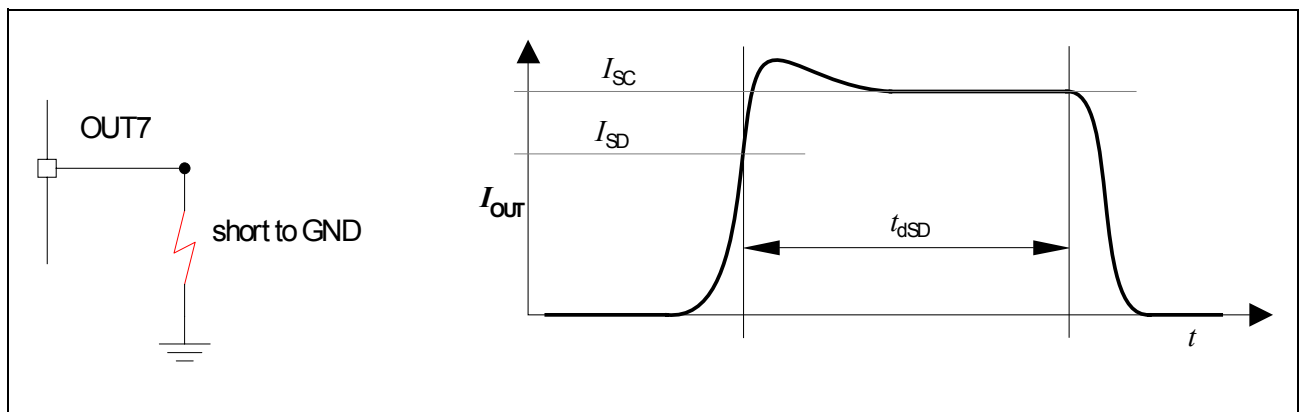

Figure 13 Short circuit protection

The output stage stays off and the error bit set until a status register reset is sent to the SPI or a power-on reset is performed.

4.5.1.2 Open Load

For the high-side switches, an open-load in OFF-state scheme is used as shown in [Figure 14](#). The output is pulled up by a current source I_{OpL} . In OFF-state, the output voltage is monitored and compared to the threshold V_{OpL} . If the voltage rises above this threshold, the open-load signal is set to high. This is equivalent to comparing the load resistance to the value V_{OpL} / I_{OpL} . The open load error bit is latched and can be reset by the SPI status register reset or by a power-on reset.

The pull-up current can be switched on and off by the OpLxON bits. This bit should be set to LOW (i.e. pull-up current switched off) if an output is used to drive LEDs because they may emit light if biased with the pull-up current.

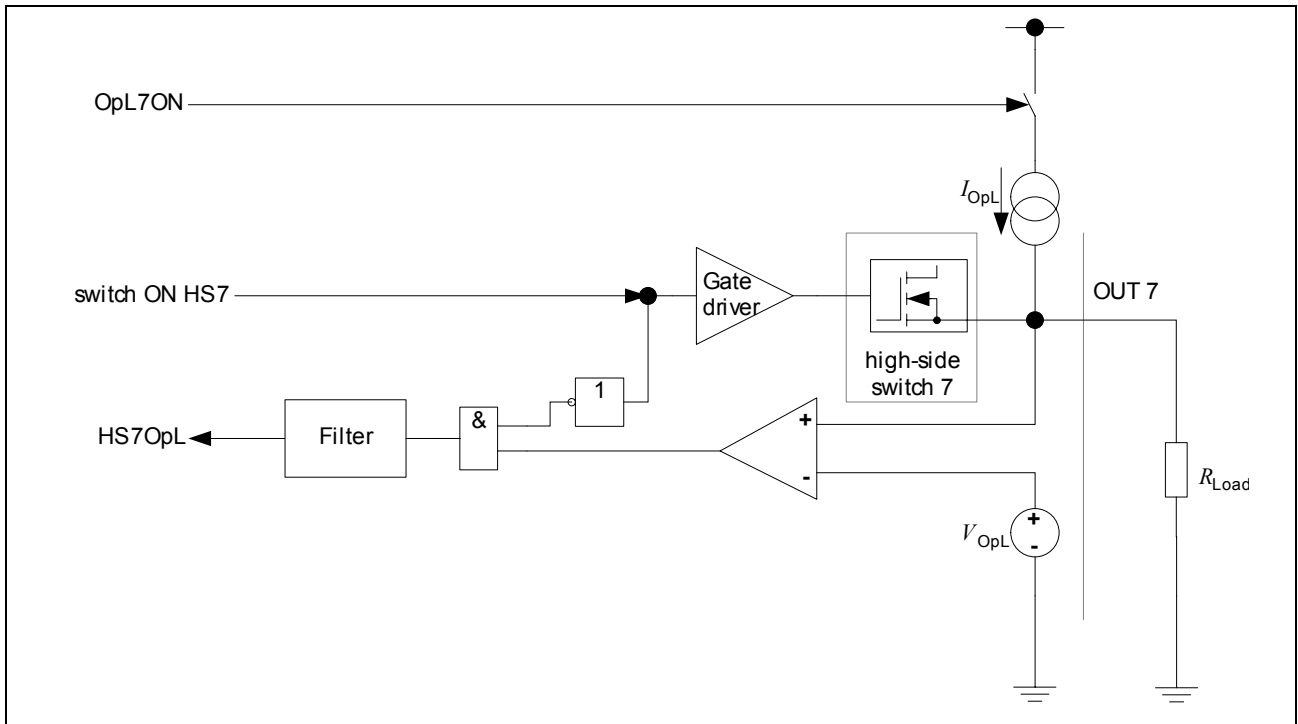

Figure 14 Open load in OFF-state scheme

4.5.2 Electrical Characteristics

Electrical Characteristics OUT 7 (mirror heater driver)

8 V < V_S < 20 V; 4.75 V < V_{CC} < 5.25 V; INH = High; all outputs open;
 -40 °C < T_j < 150 °C; unless otherwise specified

| Pos. | Parameter | Symbol | Limit Values | | | Unit | Conditions |
|------|-----------|--------|--------------|------|------|------|------------|
| | | | min. | typ. | max. | | |

Static Drain-source ON-Resistance

| | | | | | | | |
|-------|------------------|--------------------|---|---|-----|----|--|
| 4.5.1 | High-side switch | $R_{DS\text{ON}7}$ | – | – | 100 | mΩ | $I_{\text{OUT}} = 2.5 \text{ A};$ $T_j = 25 \text{ °C}$ |
| | | | – | – | 170 | mΩ | |

Switching Times

| | | | | | | | |
|-------|---------------------|---------------------|---|----|----|----|--|
| 4.5.2 | Turn-ON delay time | $t_{d\text{ONH}7}$ | – | 5 | 15 | μs | $V_S = 14 \text{ V},$ resistive load of 10 Ω, see Figure 15 |
| 4.5.3 | Output rise-time | $t_{\text{rise}7}$ | – | 15 | 40 | μs | |
| 4.5.4 | Turn-OFF delay time | $t_{d\text{OFFH}7}$ | – | 20 | 40 | μs | |
| 4.5.5 | Output fall-time | $t_{\text{fall}7}$ | – | 5 | 10 | μs | |

Short Circuit Protection

| | | | | | | | |
|-------|-------------------------------------|------------|------|----|----|----|---|
| 4.5.6 | Over-current shutdown threshold | I_{SD7} | 6.25 | 8 | 11 | A | – |
| 4.5.7 | Shutdown delay time | t_{dSD7} | 10 | 25 | 50 | μs | – |
| 4.5.8 | Short Circuit current ¹⁾ | I_{SC7} | – | 12 | – | A | – |

Open Load Detection

| | | | | | | | |
|--------|---------------------|------------------|-----|---|-----|----|------------------------------|
| 4.5.9 | Pull-up current | I_{OpL} | 100 | – | 300 | μA | $V_{\text{OUT}} = 4\text{V}$ |
| 4.5.10 | Detection Threshold | V_{OpL} | 2 | – | 4 | V | – |
| 4.5.11 | Delay time | $t_{d\text{OC}}$ | – | – | 200 | μs | – |

Leakage Current

| | | | | | | | |
|--------|--------------------------|-----------------|---|---|---|----|-------------------------------|
| 4.5.12 | OFF-state output current | I_{QL} | – | – | 5 | μA | $V_{\text{OUT}} = \text{GND}$ |
|--------|--------------------------|-----------------|---|---|---|----|-------------------------------|

¹⁾ Not subject to production test - specified by design

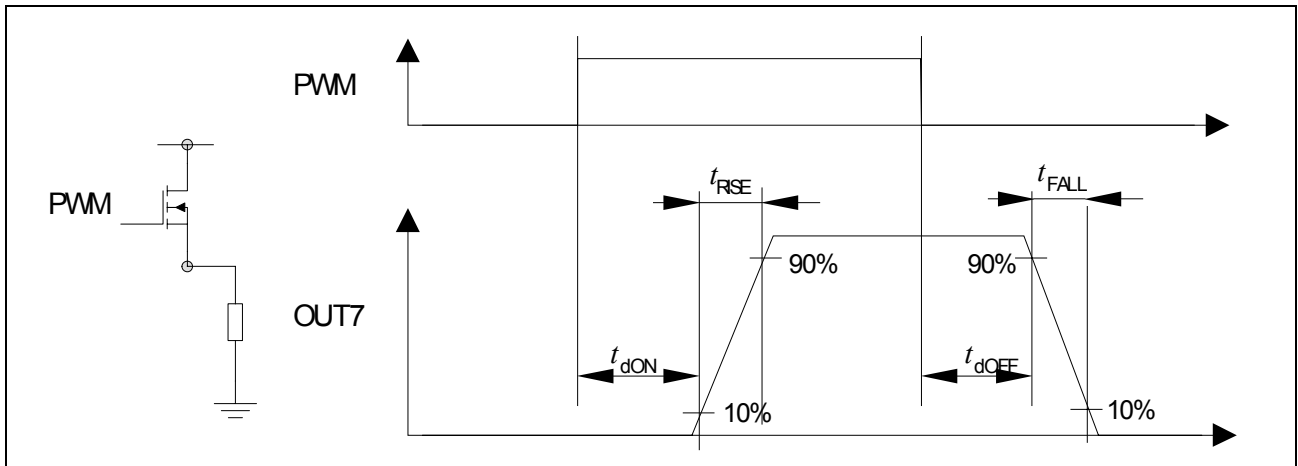

Figure 15 Timing OUT 7

4.6 Power-Outputs 8 - 11 (Lamp drivers)

Outputs 8 - 11 are a high-side switches intended to drive ohmic loads 5W or 10W lamp (bulb) loads.

4.6.1 Protection and Diagnosis

4.6.1.1 Short Circuit of Output to Ground

The high-side switches are protected against short to GND.

The high-side switches Out 8 - 11 are protected against short to GND.

Short Circuit during switch-on

During switch-on of an output a current and voltage level is used to check for a short circuit. If a switch is turned on and the short circuit condition is valid after t_{dSDon8} the output transistor is turned off and the corresponding diagnosis bit is set. A short circuit condition is valid if the current rises above the shutdown threshold I_{SD8} and the voltage at the output stays below V_{SD8} . During the delay time, the current is limited to I_{SC8} as shown in [Figure 16](#)

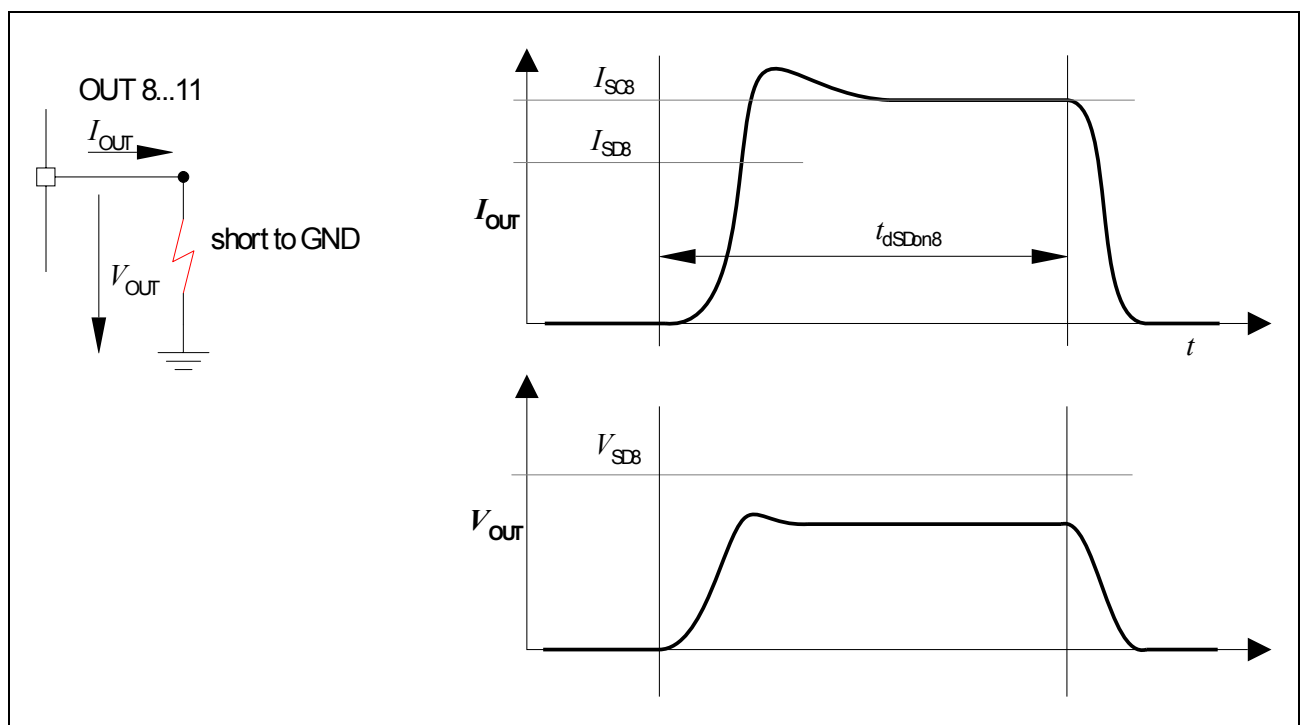

Figure 16 Short circuit protection during switch-on

Short Circuit in On-state

If a switch is already on and the current rises above the shutdown threshold I_{SD} for longer than the shutdown delay time t_{dSD} the output transistor is turned off and the corresponding diagnosis bit is set. This is independent of the voltage V_{out} . See [Figure 17](#)

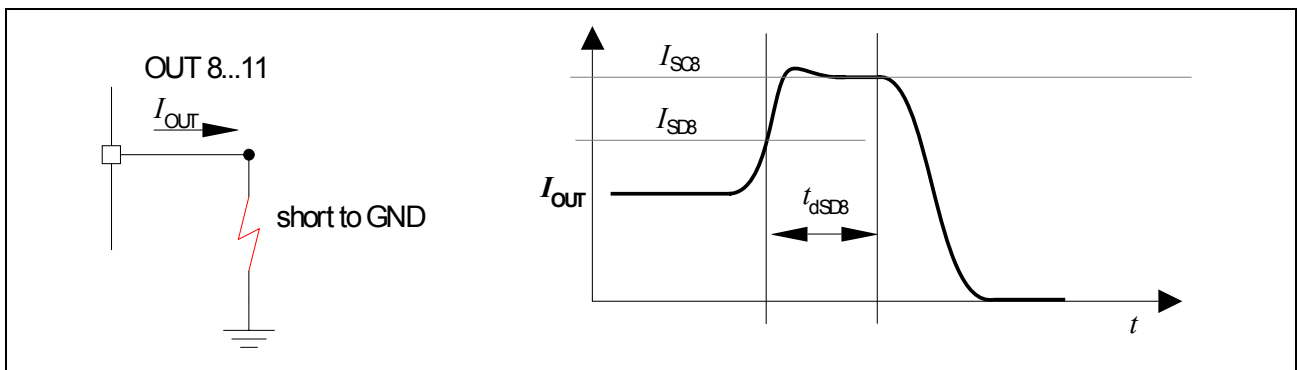

Figure 17 Short circuit protection in on-state

4.6.1.2 Open Load

For the high-side switches, an open-load in OFF-state scheme is used as shown in [Figure 18](#). The output is pulled up by a current source I_{OpL} . In OFF-state, the output voltage is monitored and compared to the threshold V_{OpL} . If the voltage rises above this threshold, the open-load signal is set to high. This is equivalent to comparing the load resistance to the value V_{OpL} / I_{OpL} . The open load error bit is latched and can be reset by the SPI status register reset or by a power-on reset.

The pull-up current can be switched on and off by the OpLxON bits. This bit should be set to LOW (i.e. pull-up current switched off) if an output is used to drive LEDs because they may emit light if biased with the pull-up current.

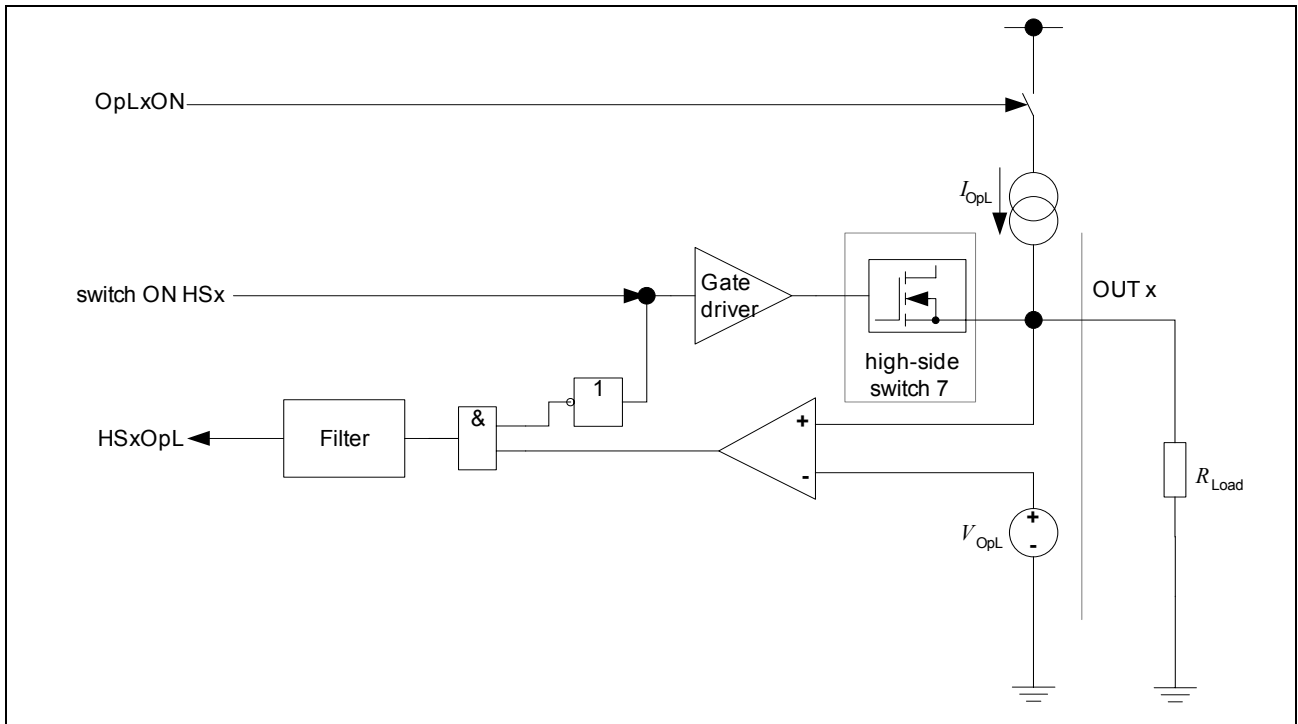

Figure 18 Open load in OFF-state scheme

4.6.2 Electrical Characteristics

Electrical Characteristics OUT 8 - 11 (Lamp drivers)

8 V < V_S < 20 V; 4.75 V < V_{CC} < 5.25 V; INH = High; all outputs open;
 -40 °C < T_j < 150 °C; unless otherwise specified

| Pos. | Parameter | Symbol | Limit Values | | | Unit | Conditions |
|------|-----------|--------|--------------|------|------|------|------------|
| | | | min. | typ. | max. | | |

Static Drain-source ON-Resistance

| | | | | | | | |
|-------|------------------|-------------|---|---|-----|----------|--------------------------------------|
| 4.6.1 | High-side switch | R_{DSON8} | – | – | 0.5 | Ω | $I_{OUT} = +0.5$ A; $T_j = 25$ °C |
| | | | – | – | 0.8 | Ω | $I_{OUT} = +0.5$ A |

Switching Times

| | | | | | | | |
|-------|---------------------|--------------|---|----|----|---------|--|
| 4.6.2 | Turn-ON delay time | t_{dONH8} | – | 5 | 15 | μ s | $V_S = 14$ V, resistive load of 25 Ω , see Figure 19 |
| 4.6.3 | Output rise-time | t_{rise8} | 5 | 10 | 30 | μ s | |
| 4.6.4 | Turn-OFF delay time | t_{dOFFH8} | – | 25 | 50 | μ s | |
| 4.6.5 | Output fall-time | t_{fall8} | 7 | 15 | 30 | μ s | |

Short Circuit Protection

| | | | | | | | |
|--------|---|--------------|-----|-----|-----|---------|-----------------|
| 4.6.6 | Over-current shutdown threshold | I_{SD8} | 1.8 | 2.9 | 3.5 | A | |
| 4.6.7 | Over-current shutdown threshold voltage | V_{SD8} | 1.5 | 2.5 | 3.3 | V | |
| 4.6.8 | Short circuit current ¹⁾ | I_{SC8} | – | 4.2 | – | A | |
| 4.6.9 | Shutdown delay time | t_{dSDon8} | 125 | 200 | 350 | μ s | at switching-on |
| 4.6.10 | Shutdown delay time | t_{dSD8} | 10 | 25 | 60 | μ s | in on-state |

Open Load Detection

| | | | | | | | |
|--------|---------------------|------------|-----|---|-----|---------|-----------------|
| 4.6.11 | Pull-up current | I_{OpL8} | 100 | – | 250 | μ A | $V_{OUT} = 4$ V |
| 4.6.12 | Detection Threshold | V_{OpL8} | 2 | – | 4 | V | – |
| 4.6.13 | Delay time | t_{dOC8} | – | – | 200 | μ s | – |

Leakage Current

| | | | | | | | |
|--------|--------------------------|----------|---|---|---|---------|-----------------|
| 4.6.14 | OFF-state output current | I_{QL} | – | – | 5 | μ A | $V_{OUT} =$ GND |
|--------|--------------------------|----------|---|---|---|---------|-----------------|

¹⁾ Not subject to production test - specified by design.

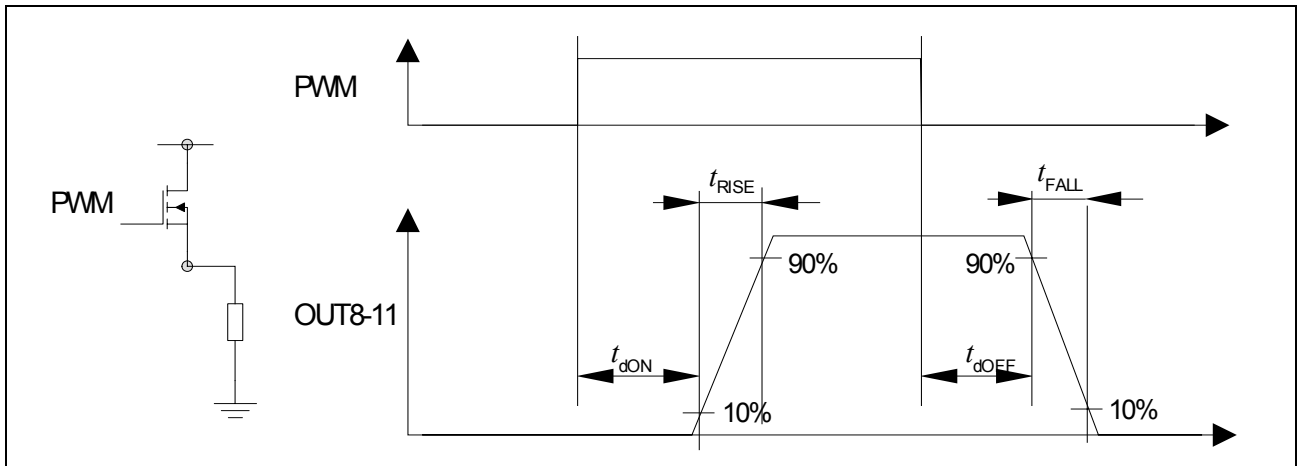

Figure 19 Timing OUT 8 - 11

4.7 Logic In- and Outputs

The threshold specifications of the logic inputs are compatible to both 5V and 3.3V standard CMOS micro controller outputs. The logic output DO is a 5V CMOS output

4.7.1 Electrical Characteristics

Electrical Characteristics Diagnostics

$8\text{ V} < V_S < 20\text{ V}$; $4.75\text{ V} < V_{CC} < 5.25\text{ V}$; INH = High; all outputs open;
 $-40\text{ °C} < T_j < 150\text{ °C}$; unless otherwise specified

| Pos. | Parameter | Symbol | Limit Values | | | Unit | Conditions |
|---|---|-------------|----------------|----------------|------|---------------|---|
| | | | min. | typ. | max. | | |
| Inhibit Input | | | | | | | |
| 4.7.15 | H-input voltage threshold | V_{IH} | – | – | 2 | V | V_{IN} rising |
| 4.7.16 | L-input voltage threshold | V_{IL} | 1 | – | – | V | V_{IN} falling |
| 4.7.17 | Hysteresis of input voltage | V_{IHY} | 100 | – | 600 | mV | – |
| 4.7.18 | Pull down current | I_{IINH} | – | – | 50 | μA | $V_{IINH} = 2\text{ V}$ |
| Logic Inputs DI, CLK, CSN, PWM1 and PWM2 | | | | | | | |
| 4.7.19 | H-input voltage threshold | V_{IH} | – | – | 2 | V | V_{IN} rising |
| 4.7.20 | L-input voltage threshold | V_{IL} | 1 | – | – | V | V_{IN} falling |
| 4.7.21 | Hysteresis of input voltage | V_{IHY} | 100 | – | 600 | mV | – |
| 4.7.22 | Pull up current at pin CSN | I_{ICSN} | -50 | -25 | -10 | μA | $V_{CSN} = 1\text{ V}$ |
| 4.7.23 | Pull down current at pins PWM1, PWM2, DI, CLK | I_{Input} | 10 | 25 | 50 | μA | $V_{Input} = 2\text{ V}$ |
| 4.7.24 | Input capacitance at pin CSN, DI, CLK, PWM1, PWM2 ¹⁾ | C_I | – | 10 | 15 | pF | $0\text{ V} < V_{CC} < 5.25\text{ V}$ |
| Logic Output DO | | | | | | | |
| 4.7.25 | H-output voltage level | V_{DOH} | $V_{CC} - 1.0$ | $V_{CC} - 0.7$ | – | V | $I_{SDOH} = 1\text{ mA}$ |
| 4.7.26 | L-output voltage level | V_{DOL} | – | 0.2 | 0.4 | V | $I_{SDOL} = -1.6\text{ mA}$ |
| 4.7.27 | Tri-state leakage current | I_{DOLK} | -10 | – | 10 | μA | $V_{CSN} = V_{CC}$ $0\text{ V} < V_{SDO} < V_{CC}$ |
| 4.7.28 | Tri-state input capacitance ¹⁾ | C_{DO} | – | 10 | 15 | pF | $V_{CSN} = V_{CC}$ $0\text{ V} < V_{CC} < 5.25\text{ V}$ |

¹⁾ Not subject to production test, specified by design

5 Application Description

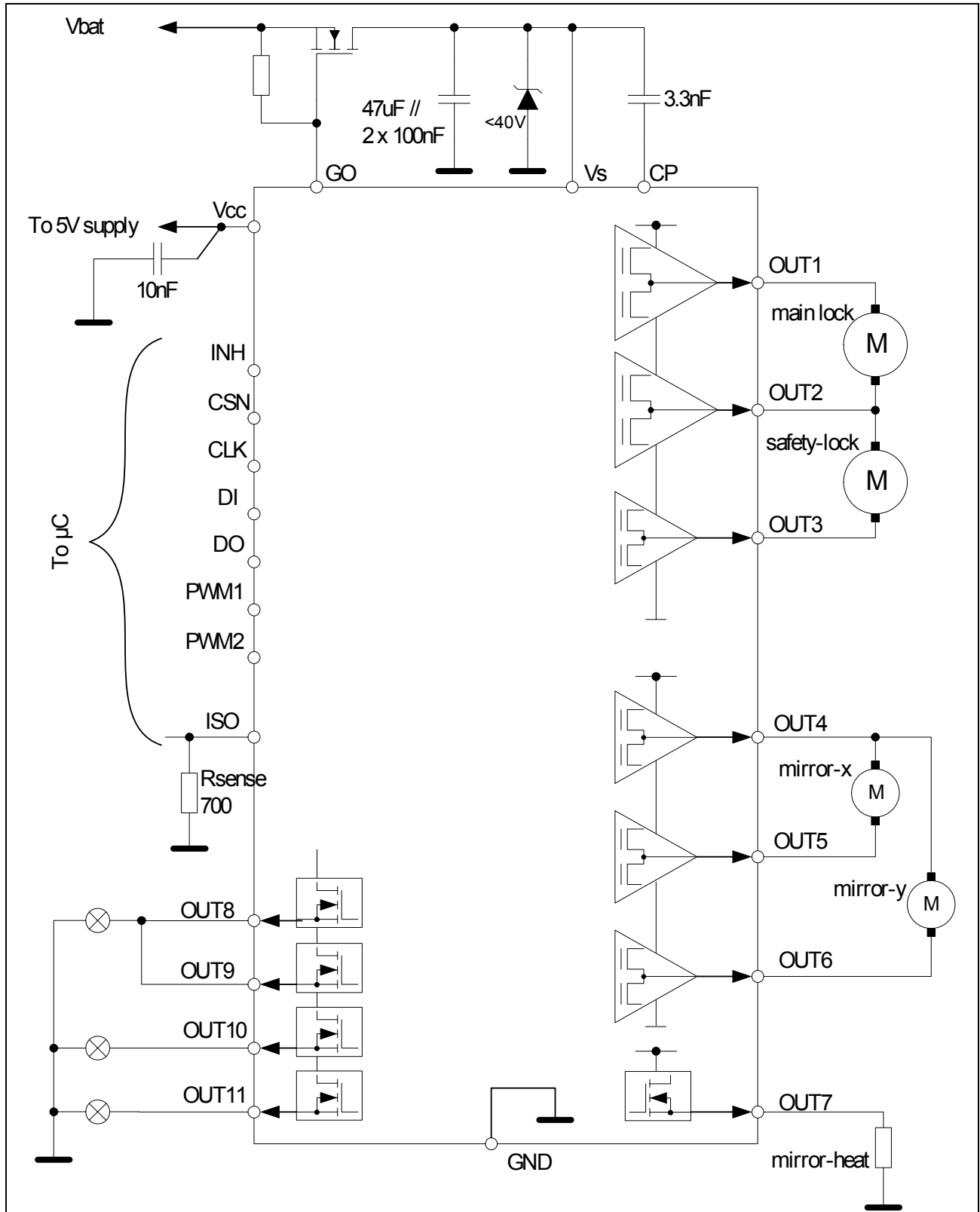

Figure 20 Application example with two-motor (safety-) lock

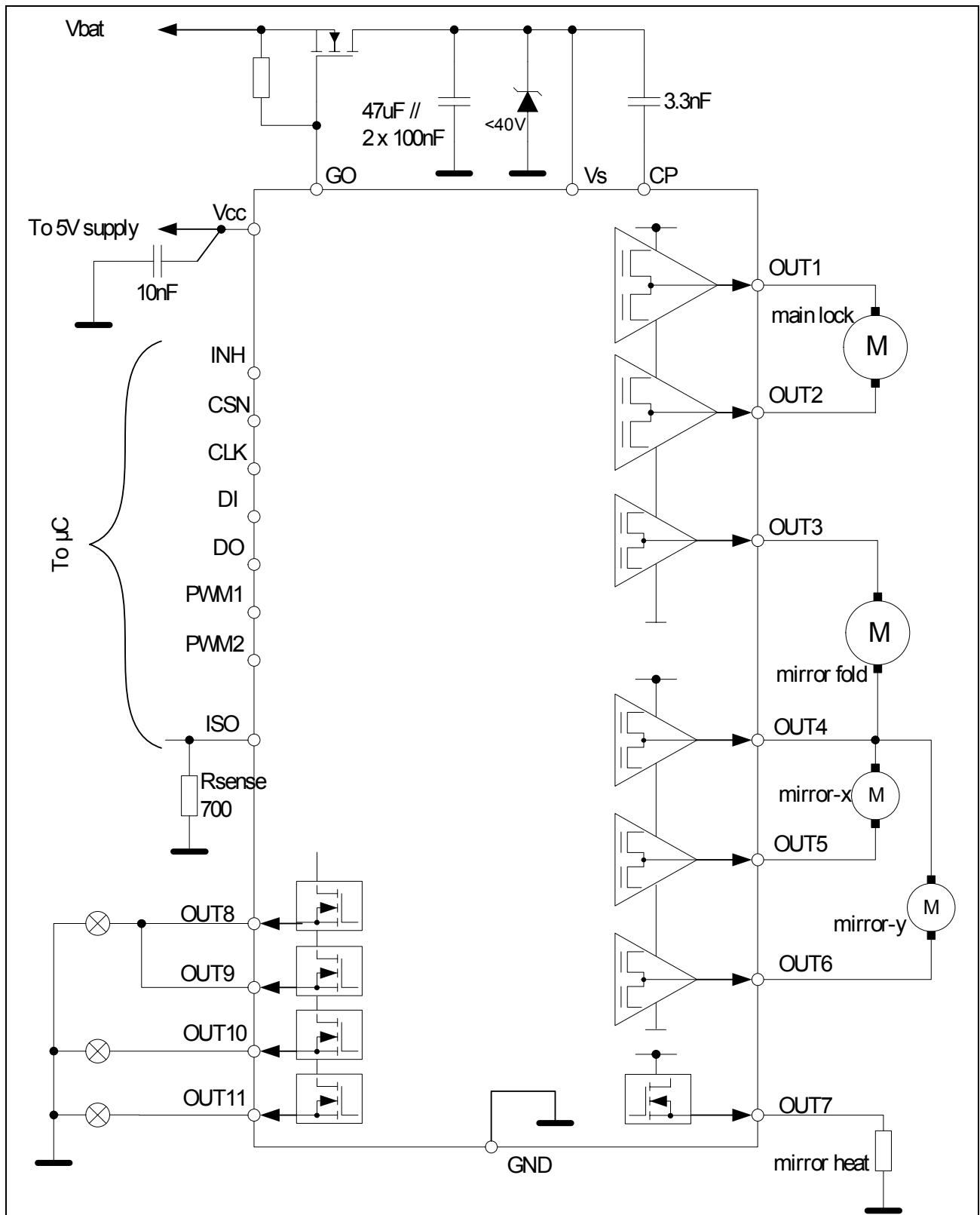
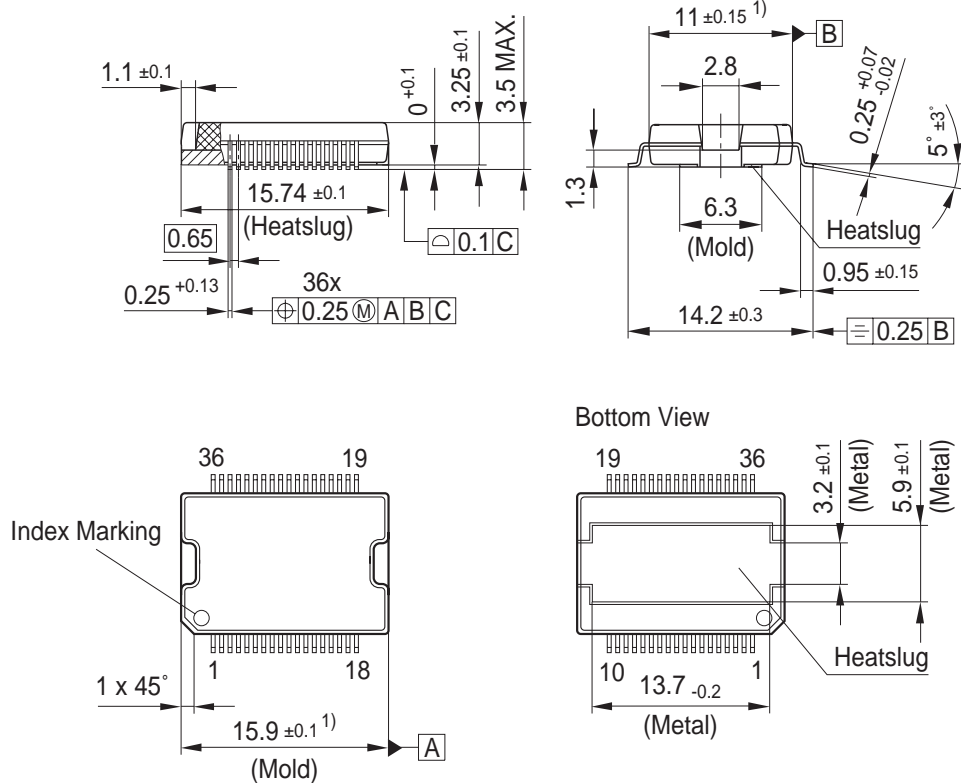

Figure 21 Application example with mirror-fold

6 Package Outlines

PG-DSO-36-27 (Plastic Dual Small Outline Package)



¹⁾ Does not include plastic or metal protrusion of 0.15 max. per side

GPS09181

You can find all of our packages, sorts of packing and others in our Infineon Internet Page "Products": <http://www.infineon.com/products>.

SMD = Surface Mounted Device

Dimensions in mm

Edition 2006-06-07

**Published by Infineon Technologies AG,
St.-Martin-Strasse 53,
81669 München, Germany**

**© Infineon Technologies AG 2006.
All Rights Reserved.**

Attention please!

The information given in this data sheet shall in no event be regarded as a guarantee of conditions or characteristics ("Beschaffenheitsgarantie"). With respect to any examples or hints given herein, any typical values stated herein and/or any information regarding the application of the device, Infineon Technologies hereby disclaims any and all warranties and liabilities of any kind, including without limitation warranties of non-infringement of intellectual property rights of any third party.

Information

For further information on technology, delivery terms and conditions and prices please contact your nearest Infineon Technologies Office (www.infineon.com).

Warnings

Due to technical requirements components may contain dangerous substances. For information on the types in question please contact your nearest Infineon Technologies Office.

Infineon Technologies Components may only be used in life-support devices or systems with the express written approval of Infineon Technologies, if a failure of such components can reasonably be expected to cause the failure of that life-support device or system, or to affect the safety or effectiveness of that device or system. Life support devices or systems are intended to be implanted in the human body, or to support and/or maintain and sustain and/or protect human life. If they fail, it is reasonable to assume that the health of the user or other persons may be endangered.

Revision History

TLE 8201R**Revision History: 2006-06-07**

Previous Version: Preliminary Data Sheet Rev. 1.0

| Page | Subjects (major changes since last revision) |
|------|--|
|------|--|

| | |
|--|------------|
| | No changes |
|--|------------|