

SPIDER - TLE 7232G

SPI Driver for Enhanced Relay Control

Eight Channel Low-Side Switch

Automotive Power



Never stop thinking

Table of Contents	Page
Product Summary	3
1 Overview	5
1.1 Block Diagram	5
1.2 Terms	6
2 Pin Configuration	7
2.1 Pin Assignment SPIDER - TLE 7232G	7
2.2 Pin Definitions and Functions	7
3 Electrical Characteristics	9
3.1 Maximum Ratings	9
4 Block Description and Electrical Characteristics	11
4.1 Power Stages	11
4.1.1 Power Supply	11
4.1.2 Input Circuit	11
4.1.3 Inductive Output Clamp	12
4.1.4 Timing Diagrams	13
4.1.5 Electrical Characteristics	14
4.1.6 Command Description	16
4.2 Protection Functions	18
4.2.1 Over Load Protection	18
4.2.2 Over Temperature Protection	19
4.2.3 Reverse Polarity Protection	19
4.2.4 Electrical Characteristics	20
4.2.5 Command Description	21
4.3 Diagnostic Features	22
4.3.1 Electrical Characteristics	23
4.3.2 Command Description	24
4.4 Serial Peripheral Interface (SPI)	25
4.4.1 SPI Signal Description	25
4.4.2 Daisy Chain Capability	26
4.4.3 Timing Diagrams	27
4.4.4 Electrical Characteristics	28
4.4.5 SPI Protocol	30
4.4.6 Register Overview	32
5 Package Outlines SPIDER - TLE 7232G	33
6 Revision History	34

The SPIDER - TLE 7232G is an eight channel low-side power switch in P-DSO-24-3 package providing embedded protective functions. It is especially designed for standard relays in automotive applications.

A serial peripheral interface (SPI) is utilized for control and diagnosis of the device and the load. For direct control, there is an input pin available.

The power transistors are built by N-channel vertical power MOSFETs. The device is monolithically integrated in Smart Power Technology.

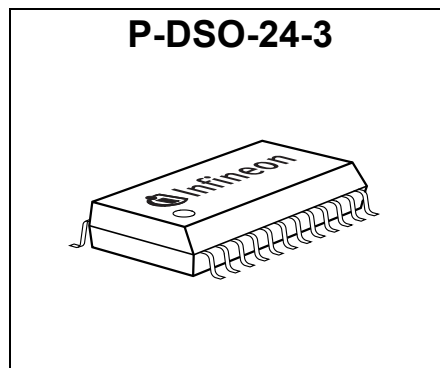

Product Summary

Supply voltage	V_{dd}	4.5 ... 5.5 V
Supply voltage for SO buffer	V_{VSO}	3.0 ... 5.5 V
On-State resistance at 25 °C	$R_{DS(ON, max)}$	1.2 Ω
Nominal load current	$I_{L(nom, max)}$	240 mA
Over load current limitation	$I_{DS(LIM, min)}$	1 A
Output leakage current per channel at 25 °C	$I_{DS(OFF, max)}$	1 μ A
Drain to source clamping voltage	$V_{DS(CL, min)}$	48 V
SPI clock frequency	$f_{SCLK(max)}$	5 MHz

Type	Ordering Code	Package
SPIDER - TLE 7232G	SP0000-89034	P-DSO-24-3

Basic Features

- 16 bit SPI for diagnostics and control
- SPI providing daisy chain capability
- 3.3 V and 5 V compatible SPI
- A configurable input pin offers complete flexibility for PWM operation
- Stable behavior at under voltage

Protective Functions

- Short circuit protection
- Over load protection, configurable behavior (limitation or shutdown)
- Thermal shutdown, configurable behavior (latch or restart)
- Electrostatic discharge protection (ESD)

Diagnostic Functions

- Diagnostic information via SPI
- Open load detection in OFF-state
- Shorted to GND detection in OFF-state
- Over temperature in ON-state
- Over load in ON-state

Applications

- Especially designed for driving relays in automotive applications
- All types of capacitive, resistive and inductive loads

1 Overview

The SPIDER - TLE 7232G is an eight channel low-side relay switch (1.2 Ω per channel) in P-DSO-24-3 package providing embedded protective functions. The 16 bit serial peripheral interface (SPI) is utilized for control and diagnosis of the device and the loads. The SPI interface provides daisy-chain capability in order to assemble multiple devices in one SPI chain by using the same number of micro-controller pins.

The SPIDER - TLE 7232G is equipped with one input pin that can be individually routed to the output control of each channel thus offering complete flexibility in design and PCB-layout. The input mapping as well as the boolean operation between input signal and output control signal is configured via SPI.

The device provides full diagnosis of the load, which is open load, short to GND as well as short circuit to V_{bat} detection and over load / over temperature indication. The SPI diagnosis flags indicate latched fault conditions that may have occurred.

Each output stage is protected against short circuit. In case of over load, the current of the affected channel is limited. There is a temperature sensor available for each channel to protect the device in case of over temperature. The shut down behavior in case of over load or over temperature can be configured via SPI for each channel individually.

1.1 Block Diagram

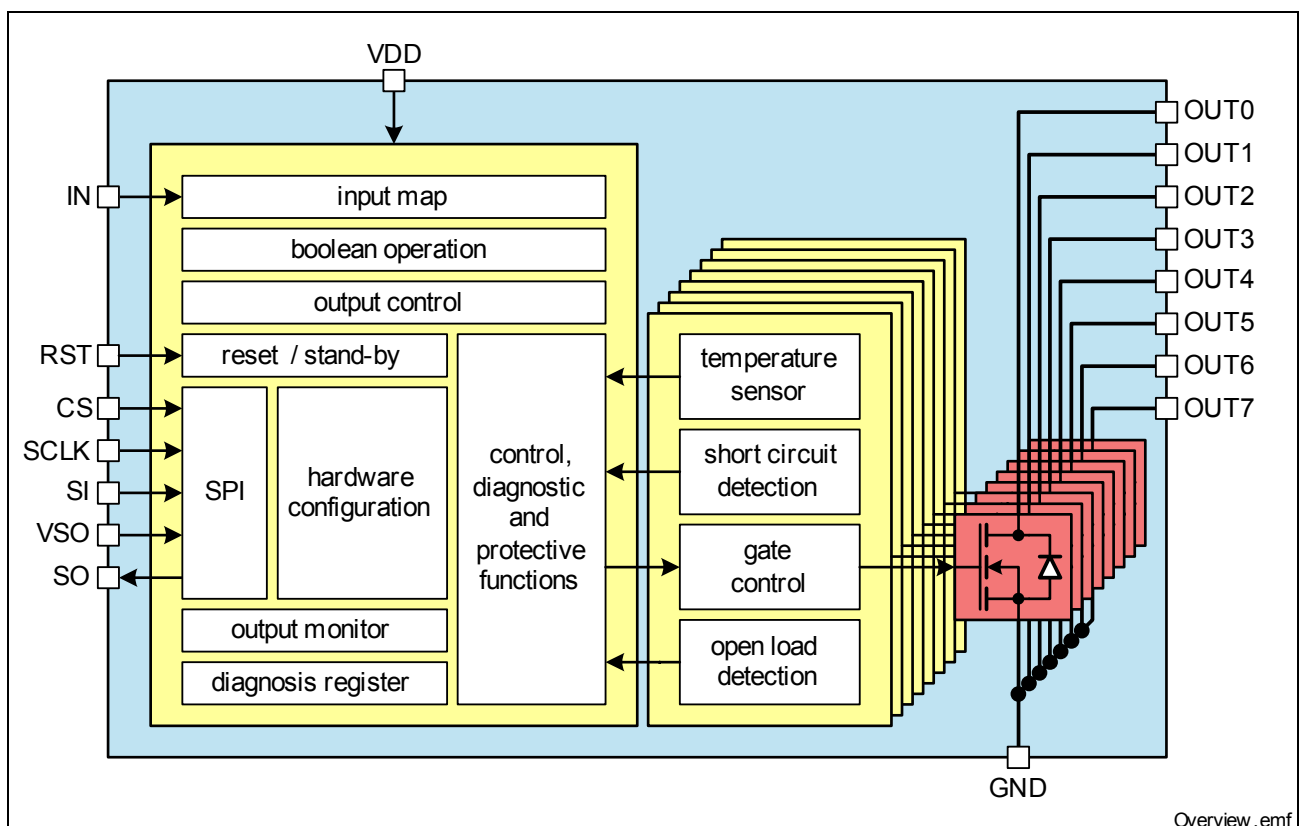

Figure 1 Block Diagram

1.2 Terms

Following figure shows all terms used in this data sheet.

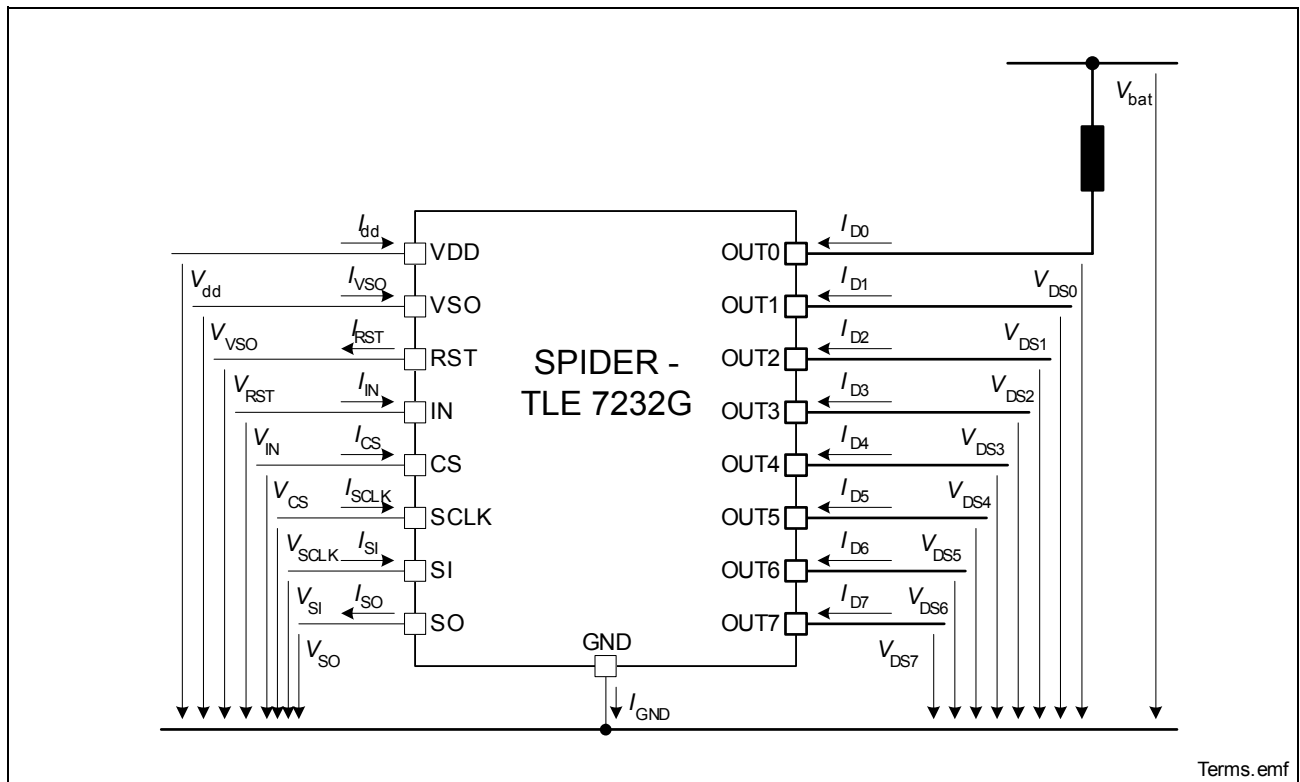

Figure 2 Terms

In all tables of electrical characteristics is valid: Channel related symbols without channel number are valid for each channel separately (e.g. V_{DS} specification is valid for $V_{DS0} \dots V_{DS7}$).

All SPI register bits are marked as follows: ADDR.PARAMETER (e.g. CTL.OUT0). In SPI register description, the values in bold letters (e.g. **0**) are default values.

2 Pin Configuration

2.1 Pin Assignment SPIDER - TLE 7232G

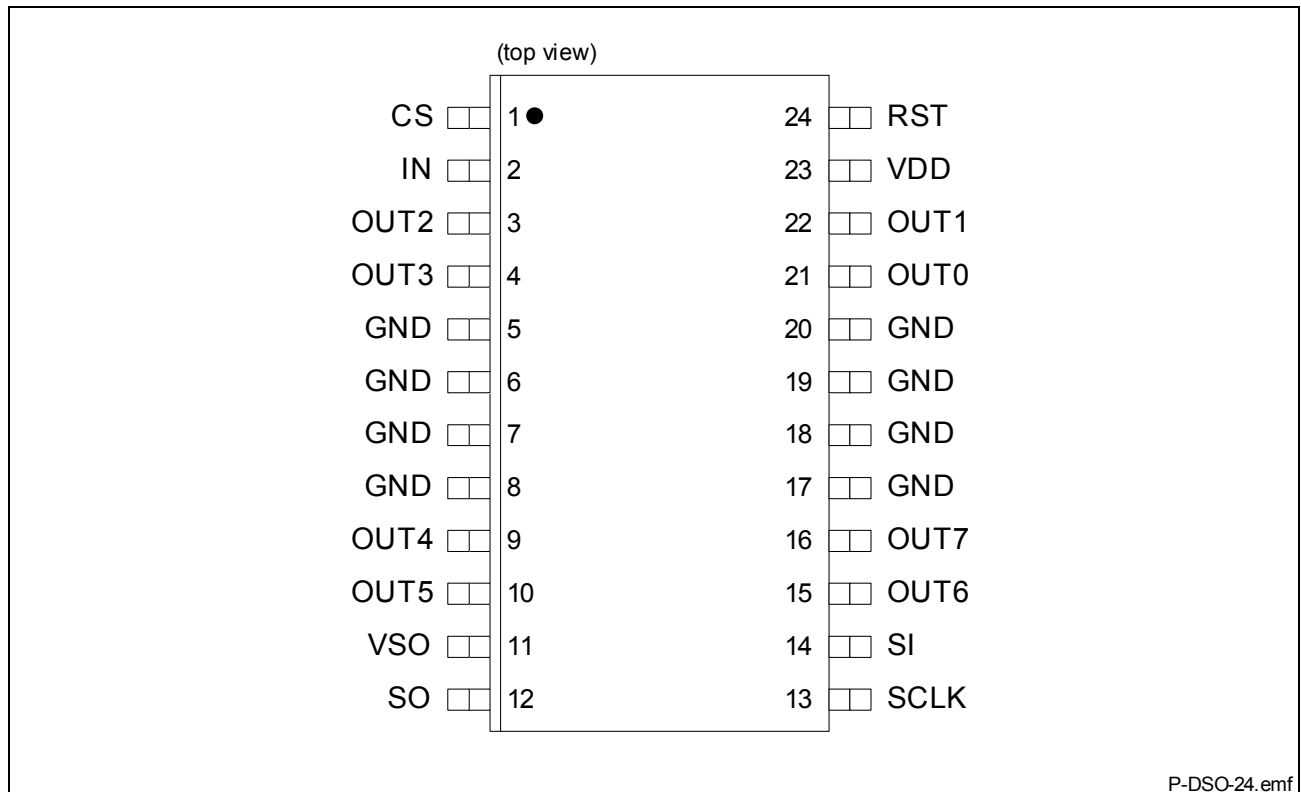

Figure 3 Pin Configuration P-DSO-24-3

2.2 Pin Definitions and Functions

Pin	Symbol	I/O	Function
Power Supply			
23	VDD	–	Power supply
11	VSO	–	Power supply for SO buffer
5, 6, 7, 8, 17, 18, 19, 20	GND	–	Ground
Power Stages			
21	OUT0	O	Drain of power transistor channel 0
22	OUT1	O	Drain of power transistor channel 1
3	OUT2	O	Drain of power transistor channel 2

Pin Configuration

Pin	Symbol	I/O	Function
4	OUT3	O	Drain of power transistor channel 3
9	OUT4	O	Drain of power transistor channel 4
10	OUT5	O	Drain of power transistor channel 5
15	OUT6	O	Drain of power transistor channel 6
16	OUT7	O	Drain of power transistor channel 7
Inputs			
24	RST	I	Reset input pin (active low)
2	IN	I	Input multiplexer input pin
SPI			
1	CS	I	SPI Chip select (active low)
13	SCLK	I	Serial clock
14	SI	I	Serial data in
12	SO	O	Serial data out

3 Electrical Characteristics

3.1 Maximum Ratings

Stresses above the ones listed here may affect device reliability or may cause permanent damage to the device.

Unless otherwise specified: $V_{dd} = 4.5 \text{ V to } 5.5 \text{ V}$, $T_j = -40 \text{ }^\circ\text{C to } 150 \text{ }^\circ\text{C}$

Pos.	Parameter	Symbol	Limit Values		Unit	Test Conditions
			min.	max.		

Power Supply

3.1.1	Power supply voltage	V_{dd}	-0.3	5.5	V	
3.1.2	VSO supply voltage	V_{VSO}	-0.3	$V_{dd} + 0.3$	V	1)
3.1.3	Power supply voltage for full short circuit protection (single pulse)	$V_{bat(SC)}$	0	20 28	V	OVL = 0 2) OVL = 1

Power Stages

3.1.4	Load current	I_D	-1	1	A	
3.1.5	Voltage at power transistor	V_{DS}		48	V	
3.1.6	Maximum energy dissipation one channel single pulse	E_{AS}		65 30	mJ	3) $T_{j(0)} = 85 \text{ }^\circ\text{C}$ $I_{D(0)} = 0.35 \text{ A}$ $T_{j(0)} = 150 \text{ }^\circ\text{C}$ $I_{D(0)} = 0.25 \text{ A}$
	Maximum energy dissipation one channel repetitive pulses $1 \cdot 10^4$ cycles $1 \cdot 10^6$ cycles	E_{AR}		18 13	mJ	3) $T_{j(0)} = 150 \text{ }^\circ\text{C}$ $I_{D(0)} = 0.20 \text{ A}$ $I_{D(0)} = 0.17 \text{ A}$

Logic Pins

3.1.7	Voltage at input pin	V_{IN}	-0.3	5.5	V	
3.1.8	Voltage at reset pin	V_{RST}	-0.3	5.5	V	
3.1.9	Voltage at chip select pin	V_{CS}	-0.3	5.5	V	
3.1.10	Voltage at serial clock pin	V_{SCLK}	-0.3	5.5	V	

Electrical Characteristics

Unless otherwise specified: $V_{dd} = 4.5 \text{ V to } 5.5 \text{ V}$, $T_j = -40 \text{ }^\circ\text{C to } 150 \text{ }^\circ\text{C}$

Pos.	Parameter	Symbol	Limit Values		Unit	Test Conditions
			min.	max.		
3.1.11	Voltage at serial input pin	V_{SI}	-0.3	5.5	V	
3.1.12	Voltage at serial output pin	V_{SO}	-0.3	5.5	V	

Temperatures

3.1.13	Junction Temperature	T_j	-40	150	$^\circ\text{C}$	
3.1.14	Dynamic temperature increase while switching	ΔT_j		60	$^\circ\text{C}$	
3.1.15	Storage Temperature	T_{stg}	-55	150	$^\circ\text{C}$	

ESD Susceptibility

3.1.16	ESD susceptibility HBM	V_{ESD}	-2	2	kV	according to EIA/JESD 22-A 114B
--------	------------------------	-----------	----	---	----	---------------------------------

- 1) $V_{dd} + 0.3 \text{ V} < 5.5 \text{ V}$
- 2) Details on configuration of protective function OLCR.OVL can be found in [Section 4.2.5](#)
- 3) Pulse shape represents inductive switch off: $I_D(t) = I_D(0) \times (1 - t / t_{pulse})$; $0 < t < t_{pulse}$

4 Block Description and Electrical Characteristics

4.1 Power Stages

The SPIDER - TLE 7232G is an eight channel low-side relay switch. The power stages are built by N-channel vertical power MOSFET transistors.

4.1.1 Power Supply

The SPIDER - TLE 7232G is supplied by power supply line V_{dd} which is used for the digital as well as the analog functions of the device including the gate control of the power stages. There is a power-on reset function implemented for the supply line. After start-up of the power supply, all SPI registers are reset to their default values. A capacitor at pins VDD to GND is recommended.

The voltage at pin VSO is used by the driver of the SO line at the SPI. It is designed to be functional at a wide voltage range.

There is a reset pin available. At low level at this pin, all registers are set to their default values and the quiescent supply current is minimized.

4.1.2 Input Circuit

There is an input pin available at SPIDER - TLE 7232G to control the output stages.

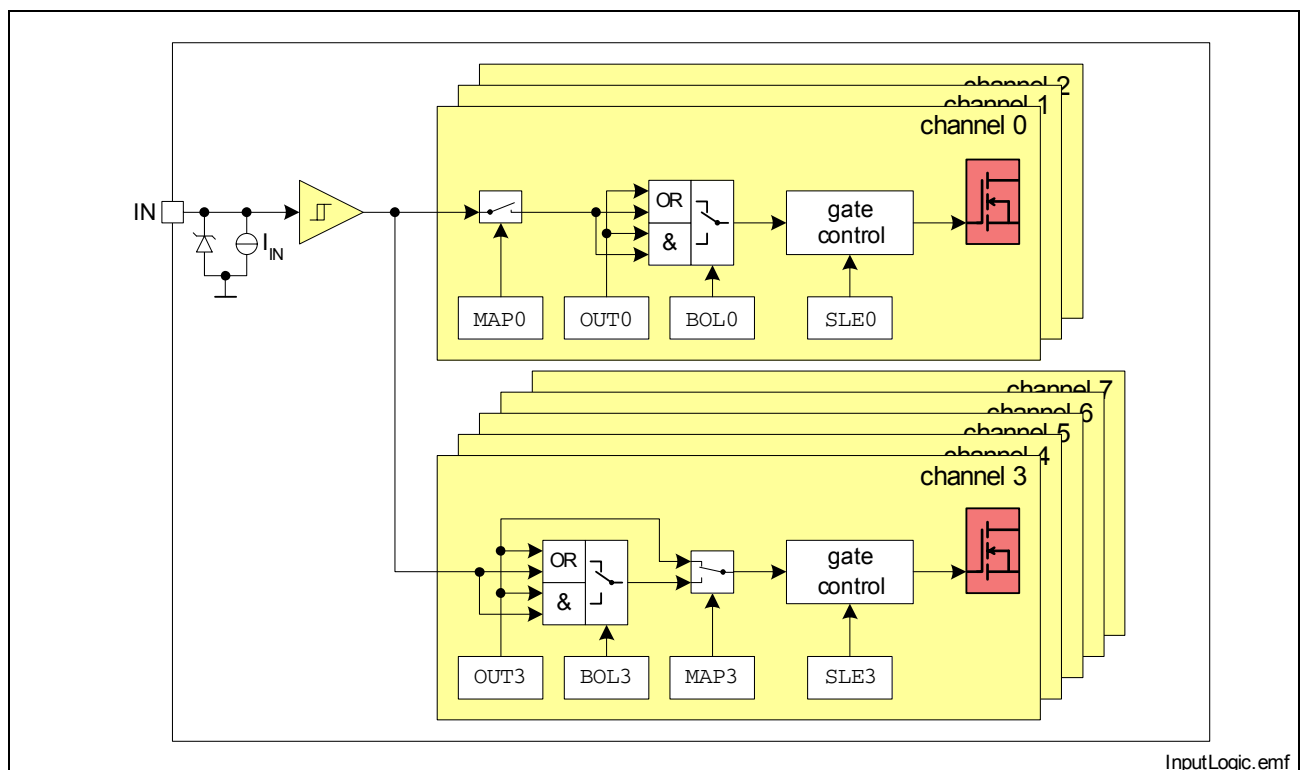

Figure 4 Input Mapping and Boolean Operator

Block Description and Electrical Characteristics

The input signal can be configured to be used as control signal of the output stages for each channel separately. The channels 0 to 3 differ from the channels 4 to 7 in the mapping behavior. Please refer to [Figure 4](#) for details.

The current sink to ground at the input pin ensures that the channels switch off in case of open pin. The zener diode protects the input circuit against ESD pulses.

4.1.3 Inductive Output Clamp

When switching off inductive loads, the potential at pin OUT rises to $V_{DS(CL)}$ potential, because the inductance intends to continue driving the current. The voltage clamping is necessary to prevent destruction of the device, see [Figure 5](#) for details. Nevertheless, the maximum allowed load inductance is limited.

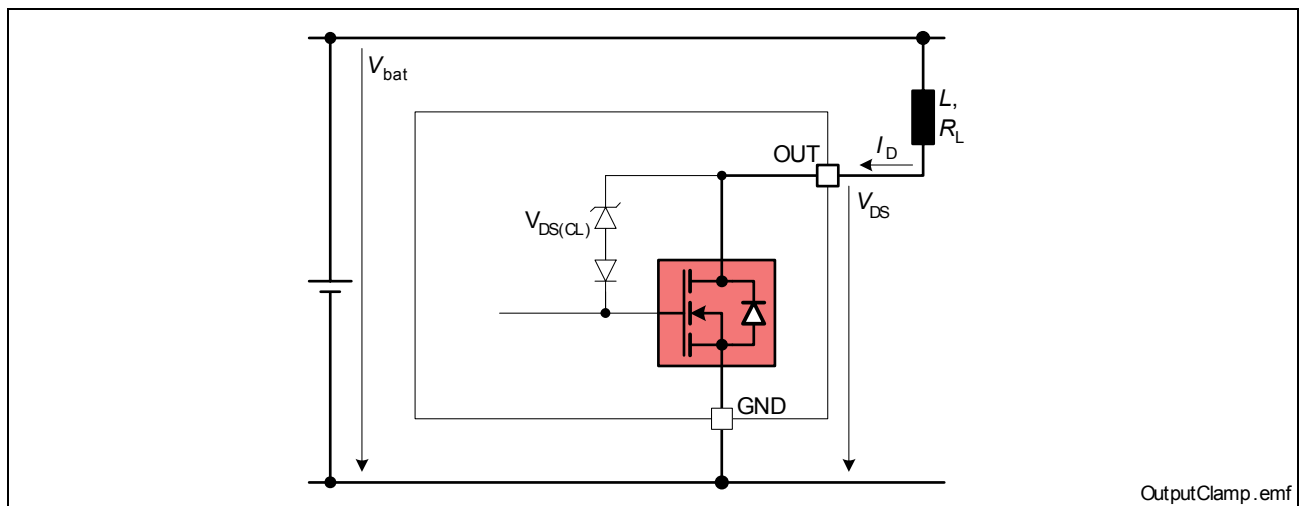

Figure 5 Output Clamp Implementation

Maximum Load Inductance

During demagnetization of inductive loads, energy has to be dissipated in the SPIDER - TLE 7232G. This energy can be calculated with following equation:

$$E = V_{DS(CL)} \cdot \left[\frac{V_{bat} - V_{DS(CL)}}{R_L} \cdot \ln \left(1 - \frac{R_L \cdot I_D}{V_{bat} - V_{DS(CL)}} \right) + I_D \right] \cdot \frac{L}{R_L} \quad (1)$$

The equation simplifies under the assumption of $R_L = 0$:

$$E = \frac{1}{2} L I_D^2 \cdot \left(1 - \frac{V_{bat}}{V_{bat} - V_{DS(CL)}} \right) \quad (2)$$

The energy, which is converted into heat, is limited by the thermal design of the component.

4.1.4 Timing Diagrams

The power transistors are switched on and off with a dedicated slope via the OUT bits of the serial peripheral interface SPI. The switching times t_{ON} and t_{OFF} are designed equally.

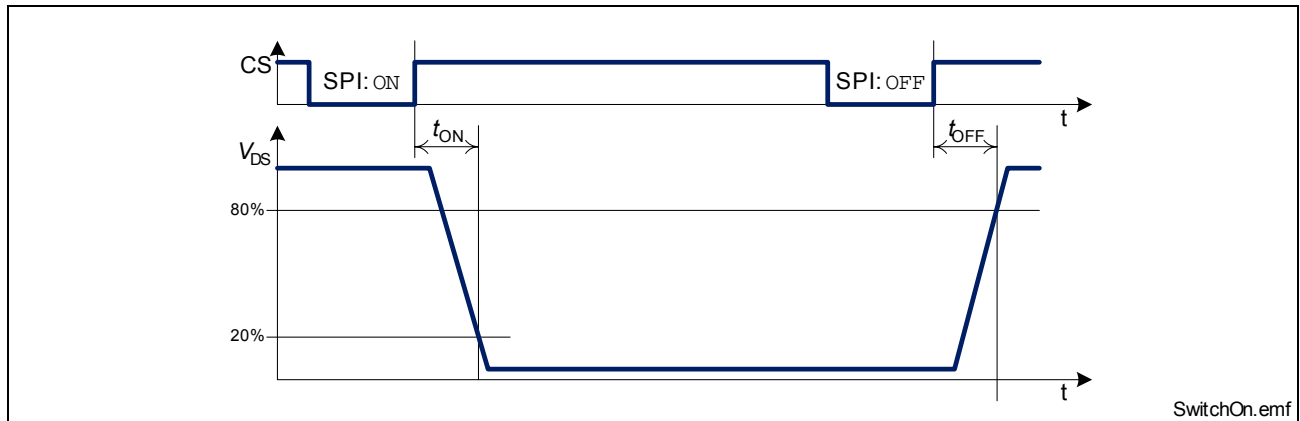

Figure 6 Switching a Resistive Load

When the input mapping is configured accordingly, a high signal at the input pin is equivalent to a SPI ON command.

Block Description and Electrical Characteristics

4.1.5 Electrical Characteristics

Unless otherwise specified: $V_{dd} = 4.5\text{ V to }5.5\text{ V}$, $T_j = -40\text{ °C to }150\text{ °C}$
 typical values: $V_{dd} = 5.0\text{ V}$, $T_j = 25\text{ °C}$

Pos.	Parameter	Symbol	Limit Values			Unit	Test Conditions
			min.	typ.	max.		
Power Supply							
4.1.1	Power supply voltage	V_{dd}	4.5		5.5	V	
4.1.2	Power supply current	$I_{dd(ON)}$		3	5	mA	all channels ON
4.1.3	Power supply reset current	$I_{dd(RST)}$			10	μA	$V_{RST} = 0\text{ V}$ $V_{IN} = 0\text{ V}$ $V_{SCLK} = 0\text{ V}$ $V_{SI} = 0\text{ V}$ $V_{CS} = V_{dd}$
4.1.4	Power-on reset threshold voltage	$V_{dd(PO)}$			4.5	V	

Output Characteristics

4.1.5	On-State resistance per channel	$R_{DS(ON)}$		1.0	1.2 2.1	Ω	$I_L = 300\text{ mA}$ $V_{dd} = 5\text{ V}$ $T_j = 25\text{ °C}^{1)}$ $T_j = 150\text{ °C}$
4.1.6	Output leakage current in stand-by mode (per channel)	$I_{D(RST)}$			1 2 5	μA	$V_{DS} = 13.5\text{ V}$ $T_j = 25\text{ °C}^{1)}$ $T_j = 125\text{ °C}$ $T_j = 150\text{ °C}^{1)}$
4.1.7	Output clamping voltage	$V_{DS(CL)}$	48		60	V	

Input Characteristics

4.1.8	L level of pin IN	$V_{IN(L)}$	0		1.0	V	
4.1.9	H level of pin IN	$V_{IN(H)}$	2.0		V_{dd}	V	
4.1.10	Input voltage hysteresis at pin IN	ΔV_{IN}		0.1		V	¹⁾
4.1.11	L-input pull-down current through pin IN	$I_{IN(L)}$	10		100	μA	¹⁾ $V_{IN} = 1\text{ V}$
4.1.12	H-input pull-down current through pin IN	$I_{IN(H)}$	20	50	100	μA	$V_{IN} = 5\text{ V}$

Block Description and Electrical Characteristics

Unless otherwise specified: $V_{dd} = 4.5\text{ V to }5.5\text{ V}$, $T_j = -40\text{ °C to }150\text{ °C}$
 typical values: $V_{dd} = 5.0\text{ V}$, $T_j = 25\text{ °C}$

Pos.	Parameter	Symbol	Limit Values			Unit	Test Conditions
			min.	typ.	max.		
Reset							
4.1.13	L level of pin RST	$V_{RST(L)}$	0		1	V	
4.1.14	H level of pin RST	$V_{RST(H)}$	2		V_{dd}	V	
4.1.15	L-input pull-up current through pin RST	$I_{RST(L)}$	0		10	μA	$V_{RST} = 1\text{ V}$
4.1.16	H-input pull-up current through pin RST	$I_{RST(H)}$	20	50	100	μA	$V_{RST} = 2\text{ V}$
Thermal Resistance							
4.1.17	Junction to ambient all channels active	R_{thja}		75		K/W	1) 2)
Timings							
4.1.18	Power-on wake up time	$t_{wu(PO)}$			200	μs	
4.1.19	Reset duration	$t_{RST(L)}$	10			μs	
4.1.20	Turn-on time $V_{DS} = 20\% V_{bat}$	t_{ON}			15 60	μs	$V_{bat} = 14\text{ V}$ $I_{DS} = 300\text{ mA}$, resistive load SLE = 0 SLE = 1
4.1.21	Turn-off time $V_{DS} = 80\% V_{bat}$	t_{OFF}			15 60	μs	$V_{bat} = 14\text{ V}$ $I_{DS} = 300\text{ mA}$, resistive load SLE = 0 SLE = 1

1) Not subject to production test, specified by design

2) Device mounted on PCB (100 mm × 100 mm × 1.5 mm). PCB without blown air. All channels with balanced loads.

Note: Characteristics show the deviation of parameter at the given supply voltage and junction temperature. Typical values show the typical parameters expected from manufacturing.

Block Description and Electrical Characteristics

4.1.6 Command Description

IMCR

Input Mapping Configuration Register

Reset Value: 08_H

7	6	5	4	3	2	1	0
MAP7	MAP6	MAP5	MAP4	MAP3	MAP2	MAP1	MAP0
rw	rw	rw	rw	rw	rw	rw	rw

Field	Bits	Type	Description
MAPn (n = 7-0)	n	rw	Input Mapping Configuration Channel n 0 Channel n can not be controlled with input pin (default value). 1 Channel n can be controlled with input pin, depending on additional set-up.

BOCR

Boolean Operator Configuration Register

Reset Value: 00_H

7	6	5	4	3	2	1	0
BOL7	BOL6	BOL5	BOL4	BOL3	BOL2	BOL1	BOL0
rw	rw	rw	rw	rw	rw	rw	rw

Field	Bits	Type	Description
BOLn (n = 7-0)	n	rw	Boolean Operator Configuration Channel n 0 Logic "OR" for channel n (default value). 1 Logic "AND" for channel n.

Block Description and Electrical Characteristics

SRCR

Slew Rate Configuration Register

Reset Value: 00_H

7	6	5	4	3	2	1	0
SLE7	SLE6	SLE5	SLE4	SLE3	SLE2	SLE1	SLE0
rW	rW	rW	rW	rW	rW	rW	rW

Field	Bits	Type	Description
SLEn (n = 7-0)	n	rW	Slew Rate Configuration Channel n 0 Channel n is switched fast (default value). 1 Channel n is switched slowly.

CTL

Output Control Register

Reset Value: 00_H

7	6	5	4	3	2	1	0
OUT7	OUT6	OUT5	OUT4	OUT3	OUT2	OUT1	OUT0
rW	rW	rW	rW	rW	rW	rW	rW

Field	Bits	Type	Description
OUTn (n = 7-0)	n	rW	Output Control Channel n 0 Channel n is switched off (default value). 1 Channel n is switched on, depending on additional set-up.

4.2 Protection Functions

The device provides embedded protective functions. Integrated protection functions are designed to prevent IC destruction under fault conditions described in this data sheet. Fault conditions are considered as “outside” normal operating range. Protection functions are not designed for continuous repetitive operation.

There is an over load and over temperature protection implemented in the SPIDER - TLE 7232G. The behavior of the protective functions can be set-up via SPI. Following figure gives an overview about the protective functions.

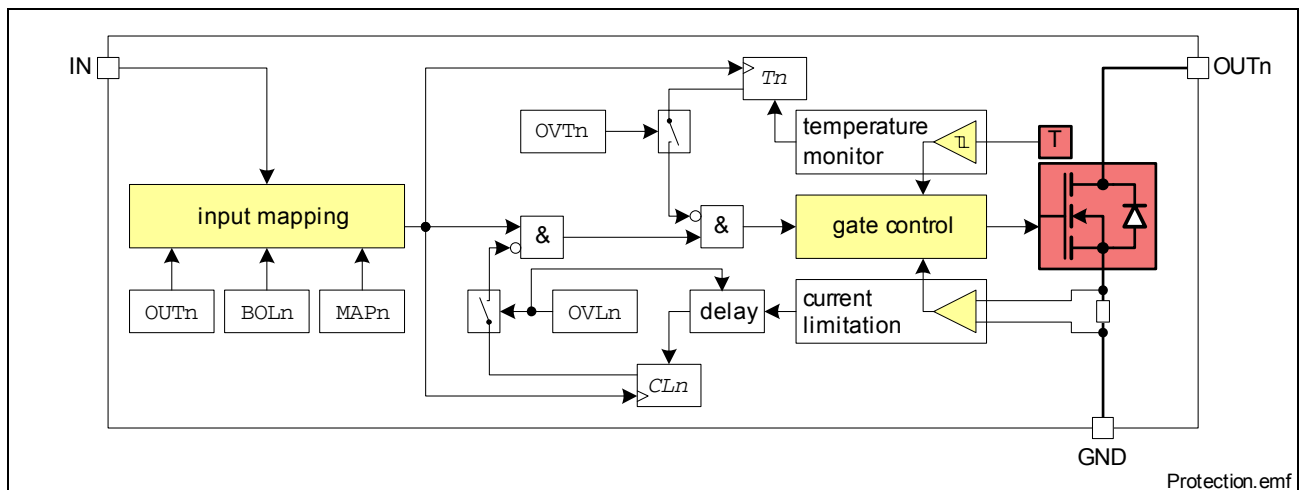

Figure 7 Protective Functions

4.2.1 Over Load Protection

The SPIDER - TLE 7232G is protected in case of over load or short circuit of the load. The behavior in case of over load can be configured as follows:

- The current is limited to $I_{DS(LIM)}$. After time $t_{d(fault)}$, the according over load flag L_n is set. The channel may shut down due to over temperature.
- The current is limited to $I_{DS(LIM)}$. After time $t_{d(off)}$, the over loaded channel n switches off and the according over load flag L_n is set.

The over load flag (CL_n) of the affected channel is cleared by a low-high transition of the input signal. For timing information, please refer to [Figure 8](#) for details.

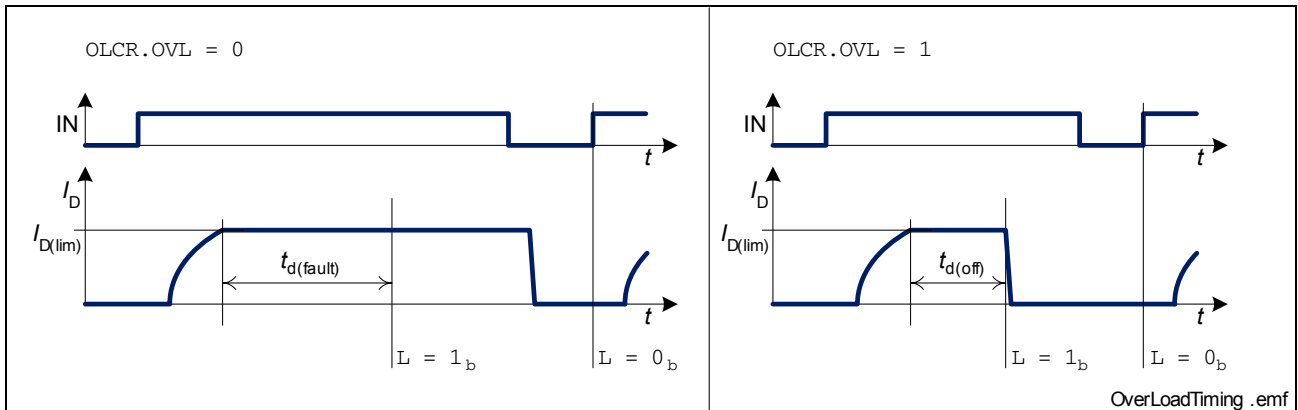

Figure 8 Over Load Behavior

4.2.2 Over Temperature Protection

A temperature sensor for each channel causes an overheated channel n to switch off immediately to prevent destruction. The behavior in case of over temperature can be configured as follows:

- After cooling down, the channel is switched on again with thermal hysteresis ΔT_j .
- The affected channel stays switched off until the over temperature flag is cleared.

The over temperature flag of the affected channel is cleared by a low-high transition of the input signal.

4.2.3 Reverse Polarity Protection

In case of reverse polarity, the intrinsic body diode of the power transistor causes power dissipation. The reverse current through the intrinsic body diode has to be limited by the connected load. The V_{dd} supply pin must be protected against reverse polarity externally. The over-temperature protection as well as other protective functions are not active during reverse polarity.

4.2.4 Electrical Characteristics

Unless otherwise specified: $V_{dd} = 4.5\text{ V to }5.5\text{ V}$, $T_j = -40\text{ °C to }150\text{ °C}$
 typical values: $V_{dd} = 5.0\text{ V}$, $T_j = 25\text{ °C}$

Pos.	Parameter	Symbol	Limit Values			Unit	Test Conditions
			min.	typ.	max.		
Over Load Protection							
4.2.1	Over load current limitation	$I_{D(lim)}$	1		2	A	OVL = 0
4.2.2	Over load shut-down delay time	$t_{d(off)}$	10		50	μs	OVL = 1
Over Temperature Protection							
4.2.3	Over temperature shut-down threshold	$T_{j(OT)}$	170		200	$^{\circ}\text{C}$	¹⁾
4.2.4	Thermal hysteresis	$\Delta T_{j(OT)}$		10		K	¹⁾

1) Not subject to production test, specified by design

4.2.5 Command Description

OLCR

Over Load Configuration Register

Reset Value: 00_H

7	6	5	4	3	2	1	0
OVL7	OVL6	OVL5	OVL4	OVL3	OVL2	OVL1	OVL0
rw	rw	rw	rw	rw	rw	rw	rw

Field	Bits	Type	Description
OVLn (n = 7-0)	n	rw	Over Load Configuration Channel n 0 Channel n limits the current in case of over load (default value). 1 Channel n shuts down in case of over load.

OTCR

Over Temperature Configuration Register

Reset Value: 00_H

7	6	5	4	3	2	1	0
OVT7	OVT6	OVT5	OVT4	OVT3	OVT2	OVT1	OVT0
rw	rw	rw	rw	rw	rw	rw	rw

Field	Bits	Type	Description
OVTn (n = 7-0)	n	rw	Over Temperature Configuration Channel n 0 Autorestart (default value) 1 Latched shut down

4.3 Diagnostic Features

The SPI of SPIDER - TLE 7232G provides diagnosis information about the device and about the load. There are following diagnosis flags implemented:

- The diagnosis information of the protective functions (flags CL_n and T_n) of channel n is latched in the diagnosis flag P_n .
- The open load diagnosis of channel n is latched in the diagnosis flag OL_n .
- The short to gnd monitor information of channel n is latched in the diagnosis flag SG_n .

All flags are cleared after a successful SPI transmission.

There is an output state monitor implemented in the device that indicates the switch state of the device in register STA . Depending on the voltage level at input pin and protective functions the bits are high or low.

Please see **Figure 9** for details:

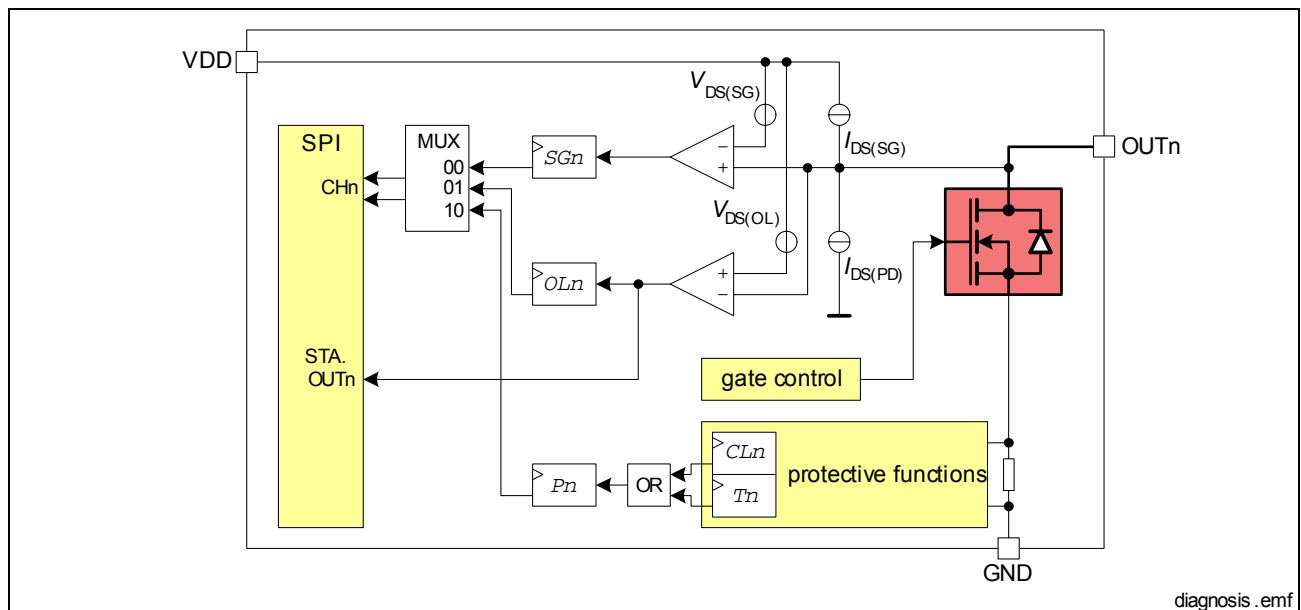

Figure 9 **Block Diagram Diagnosis**

4.3.1 Electrical Characteristics

Unless otherwise specified: $V_{dd} = 4.5\text{ V to }5.5\text{ V}$, $T_j = -40\text{ °C to }150\text{ °C}$
 typical values: $V_{dd} = 5.0\text{ V}$, $T_j = 25\text{ °C}$

Pos.	Parameter	Symbol	Limit Values			Unit	Test Conditions
			min.	typ.	max.		
OFF State Diagnosis							
4.3.1	Open load detection threshold voltage	$V_{DS(OL)}$	$V_{dd} - 2.5$	$V_{dd} - 2$	$V_{dd} - 1.3$	V	
4.3.2	Output pull-down diagnosis current per channel	$I_{D(PD)}$	50	90	150	μA	
4.3.3	Short to gnd detection threshold voltage	$V_{DS(SG)}$	$V_{dd} - 3.4$	$V_{dd} - 3.0$	$V_{dd} - 2.6$	V	
4.3.4	Output diagnosis current for short to gnd per channel	$I_{D(SG)}$	-150	-100	-50	μA	$V_{DS} = 0\text{ V}$
4.3.5	Fault delay time	$t_{d(\text{fault})}$	50	100	200	μs	

4.3.2 Command Description

STA

Output Status Monitor

Reset Value: 00_H

7	6	5	4	3	2	1	0
OUT7	OUT6	OUT5	OUT4	OUT3	OUT2	OUT1	OUT0
r	r	r	r	r	r	r	r

Field	Bits	Type	Description
OUTn (n = 7-0)	n	r	Output Status 0 Voltage level at channel n: $V_{DS} > V_{DS(OL)}$. 1 Voltage level at channel n: $V_{DS} < V_{DS(OL)}$.

4.4 Serial Peripheral Interface (SPI)

The diagnosis and control interface is based on a serial peripheral interface (SPI).

The SPI is a full duplex synchronous serial slave interface, which uses four lines: SO, SI, SCLK and $\overline{\text{CS}}$. Data is transferred by the lines SI and SO at the data rate given by SCLK. The falling edge of $\overline{\text{CS}}$ indicates the beginning of a data access. Data is sampled in on line SI at the falling edge of SCLK and shifted out on line SO at the rising edge of SCLK. Each access must be terminated by a rising edge of $\overline{\text{CS}}$. A modulo 8 counter ensures that data is taken only, when a multiple of 8 bit has been transferred. The interface provides daisy chain capability.

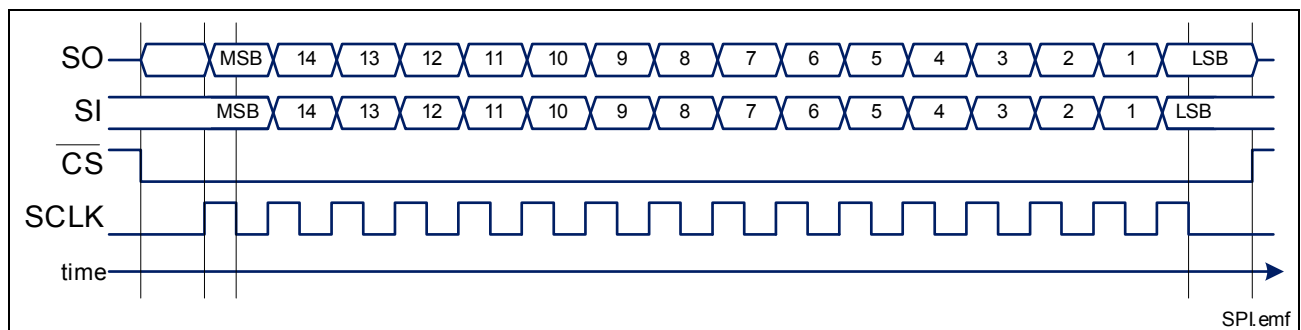

Figure 10 Serial Peripheral Interface

The SPI protocol is described in [Section 4.4.5](#). It is reset to the default values after power-on reset or a low signal at pin RST.

4.4.1 SPI Signal Description

$\overline{\text{CS}}$ - Chip Select: The system micro controller selects the SPIDER - TLE 7232G by means of the $\overline{\text{CS}}$ pin. Whenever the pin is in low state, data transfer can take place. When $\overline{\text{CS}}$ is in high state, any signals at the SCLK and SI pins are ignored and SO is forced into a high impedance state.

$\overline{\text{CS}}$ High to Low transition: 

- The diagnosis information is transferred into the shift register.

$\overline{\text{CS}}$ Low to High transition: 

- Command decoding is only done, when after the falling edge of $\overline{\text{CS}}$ exactly a multiple (1, 2, 3, ...) of eight SCLK signals have been detected.
- Data from shift register is transferred into the input matrix register.
- The diagnosis flags are cleared.

SCLK - Serial Clock: This input pin clocks the internal shift register. The serial input (SI) transfers data into the shift register on the falling edge of SCLK while the serial output

Serial Peripheral Interface (SPI)

(SO) shifts diagnostic information out on the rising edge of the serial clock. It is essential that the SCLK pin is in low state whenever chip select CS makes any transition.

SI - Serial Input: Serial input data bits are shifted in at this pin, the most significant bit first. SI information is read on the falling edge of SCLK. The 16 bit input data consist of two parts (control and data). Please refer to [Section 4.4.5](#) for further information.

SO Serial Output: Data is shifted out serially at this pin, the most significant bit first. SO is in high impedance state until the CS pin goes to low state. New data will appear at the SO pin following the rising edge of SCLK. Please refer to [Section 4.4.5](#) for further information.

4.4.2 Daisy Chain Capability

The SPI of SPIDER - TLE 7232G provides daisy chain capability. In this configuration several devices are activated by the same CS signal MCS. The SI line of one device is connected with the SO line of another device (see [Figure 11](#)), which builds a chain. The ends of the chain are connected with the output and input of the master device, MO and MI respectively. The master device provides the master clock MCLK, which is connected to the SCLK line of each device in the chain.

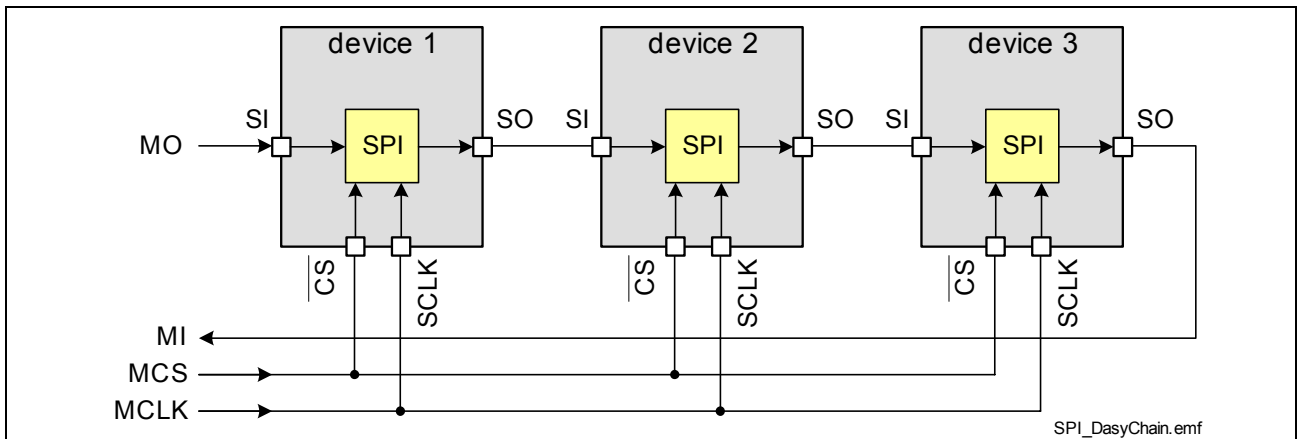

Figure 11 Daisy Chain Configuration

In the SPI block of each device, there is one shift register where one bit from SI line is shifted in each SCLK. The bit shifted out can be seen at SO. After 16 SCLK cycles, the data transfer for one device has been finished. In single chip configuration, the CS line must go high to make the device accept the transferred data. In daisy chain configuration the data shifted out at device #1 has been shifted in to device #2. When using three devices in daisy chain, three times 16 bits have to be shifted through the devices. After that, the MCS line must go high (see [Figure 12](#)).

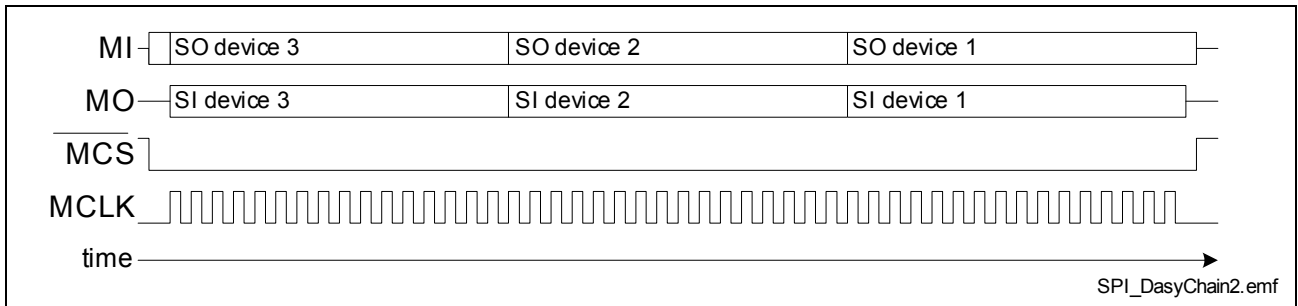

Figure 12 Data Transfer in Daisy Chain Configuration

4.4.3 Timing Diagrams

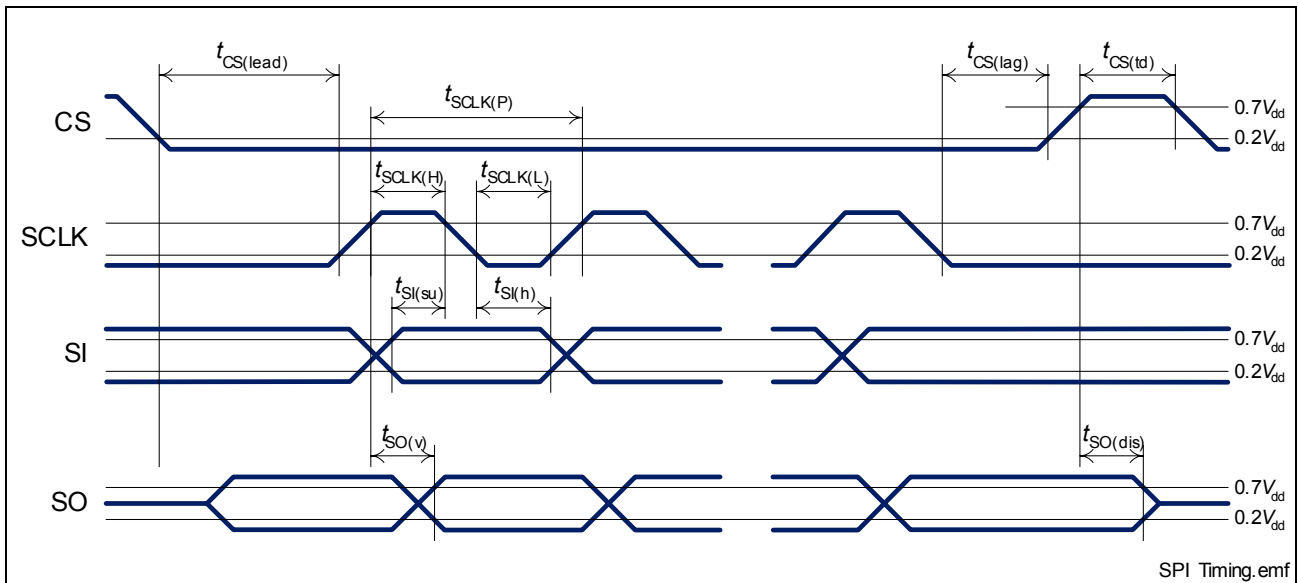

Figure 13 Timing Diagram

4.4.4 Electrical Characteristics

Unless otherwise specified:

$V_{VSO} = 3.0\text{ V to }5.5\text{ V}$, $V_{dd} = 4.5\text{ V to }5.5\text{ V}$, $T_j = -40\text{ °C to }150\text{ °C}$

typical values: $V_{VSO} = 5.0\text{ V}$, $V_{dd} = 5.0\text{ V}$, $T_j = 25\text{ °C}$

Pos.	Parameter	Symbol	Limit Values			Unit	Test Conditions
			min.	typ.	max.		

Power Supply

4.4.1	Power supply voltage for SO buffer	V_{VSO}	3.0		5.5	V	
-------	------------------------------------	-----------	-----	--	-----	---	--

Input Characteristics (CS, SCLK, SI)

4.4.2	L level of pin $\overline{\text{CS}}$ SCLK SI	$V_{CS(L)}$ $V_{SCLK(L)}$ $V_{SI(L)}$	0		1	V	
4.4.3	H level of pin $\overline{\text{CS}}$ SCLK SI	$V_{CS(H)}$ $V_{SCLK(H)}$ $V_{SI(H)}$	2		V_{dd}	V	
4.4.4	L-input pull-up current through $\overline{\text{CS}}$	$I_{CS(L)}$	10	20	50	μA	$V_{CS} = 0\text{ V}$
4.4.5	H-input pull-up current through $\overline{\text{CS}}$	$I_{CS(H)}$	5		50	μA	¹⁾ $V_{CS} = 2\text{ V}$
4.4.6	L-input pull-down current through pin SCLK SI	$I_{SCLK(L)}$ $I_{SI(L)}$	5		50	μA	¹⁾ $V_{SCLK} = 1\text{ V}$ $V_{SI} = 1\text{ V}$
4.4.7	H-input pull-down current through pin SCLK SI	$I_{SCLK(H)}$ $I_{SI(H)}$	10	20	50	μA	$V_{SCLK} = 5\text{ V}$ $V_{SI} = 5\text{ V}$

Output Characteristics (SO)

4.4.8	L level output voltage	$V_{SO(L)}$	0		0.4	V	$I_{SO} = -2.5\text{ mA}$
4.4.9	H level output voltage	$V_{SO(H)}$	4.6 2.4		5 3		$I_{SO} = 2\text{ mA}$ $V_{VSO} = 5\text{ V}$ $V_{VSO} = 3\text{ V}$
4.4.10	Output tristate leakage current	$I_{SO(OFF)}$	-10		10	μA	$V_{CS} = V_{dd}$

Serial Peripheral Interface (SPI)

Unless otherwise specified:

$V_{VSO} = 3.0\text{ V to }5.5\text{ V}$, $V_{dd} = 4.5\text{ V to }5.5\text{ V}$, $T_j = -40\text{ °C to }150\text{ °C}$

typical values: $V_{VSO} = 5.0\text{ V}$, $V_{dd} = 5.0\text{ V}$, $T_j = 25\text{ °C}$

Pos.	Parameter	Symbol	Limit Values			Unit	Test Conditions
			min.	typ.	max.		

Timings

4.4.11	Serial clock frequency	f_{SCLK}	0		5	MHz	
4.4.12	Serial clock period	$t_{SCLK(P)}$	200			ns	
4.4.13	Serial clock high time	$t_{SCLK(H)}$	50			ns	
4.4.14	Serial clock low time	$t_{SCLK(L)}$	50			ns	
4.4.15	Enable <u>lead</u> time (falling CS to rising SCLK)	$t_{SCLK(lead)}$	250			ns	
4.4.16	Enable <u>lag</u> time (falling SCLK to rising CS)	$t_{SCLK(lag)}$	250			ns	
4.4.17	Transfer <u>delay</u> time (rising CS to falling CS)	$t_{CS(del)}$	250			ns	
4.4.18	Data <u>setup</u> time (required time SI to falling SCLK)	$t_{SI(su)}$	20			ns	
4.4.19	Data <u>hold</u> time (falling SCLK to SI)	$t_{SI(h)}$	20			ns	
4.4.20	Output <u>disable</u> time (rising CS to SO tri-state)	$t_{SO(dis)}$			150	ns	¹⁾
4.4.21	Output data <u>valid</u> time with capacitive load	$t_{SO(v)}$			100	ns	$C_L = 50\text{ pF}$ ¹⁾

1) Not subject to production test, specified by design.

4.4.5 SPI Protocol

The SPI protocol of the SPIDER - TLE 7232G provides two types of registers. The control registers and the diagnosis registers. After power-on reset, all register bits set to default values.

SI

Reset Value: xxxx_H

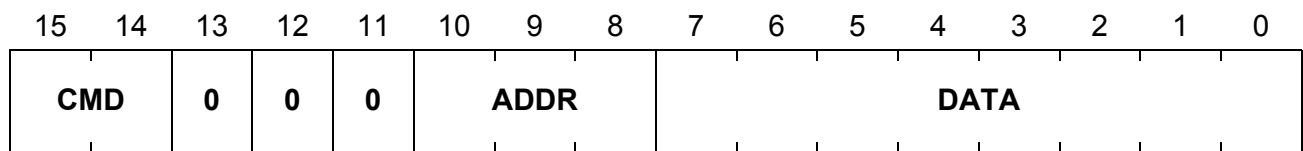

Field	Bits	Type	Description
CMD	15:14		Command 00 Diagnosis only: The requested data is shifted out at SO. This command does not change any register setting. 01 Read register: The register content of the addressed register will be sent in the next frame. 10 Reset registers: All registers are reset to their default values. 11 Write register: The data of the SI word will be written to the addressed register.
ADDR	10:8		Address Pointer to register for read and write command
DATA	7:0		Data Data written to or read from register selected by address ADDR

Serial Peripheral Interface (SPI)

SO

Standard Diagnosis

Reset Value: $xxxx_H$

15	14	13	12	11	10	9	8	7	6	5	4	3	2	1	0
CH7		CH6		CH5		CH4		CH3		CH2		CH1		CH0	

Field	Bits	Type	Description
CHn (n = 7-0)	(2n+1): 2n		Standard Diagnosis for Channel n 00 Short circuit to GND 01 Open load 10 Over load, over temperature 11 Normal operation

SO

Second Frame of Read Command

Reset Value: $xxxx_H$

15	14	13	12	11	10	9	8	7	6	5	4	3	2	1	0
0	1	0	0	0	ADDR			DATA							

Field	Bits	Type	Description
ADDR	10:8		Address Pointer to register for read and write command
DATA	7:0		Data Data written to or read from register selected by address ADDR

Note: Reading a register needs two SPI frames. In the first frame the RD command is sent. In the second frame the output at SPI signal SO will contain the requested information. A new command can be executed in the second frame.

4.4.6 Register Overview

Name	W/R	Addr	7	6	5	4	3	2	1	0	default 1)
IMCR	W/R	001 _B	MAP7	MAP6	MAP5	MAP4	MAP3	MAP2	MAP1	MAP0	08 _H
BOCR	W/R	010 _B	BOL7	BOL6	BOL5	BOL4	BOL3	BOL2	BOL1	BOL0	00 _H
OLCR	W/R	011 _B	OVL7	OVL6	OVL5	OVL4	OVL3	OVL2	OVL1	OVL0	00 _H
OTCR	W/R	100 _B	OVT7	OVT6	OVT5	OVT4	OVT3	OVT2	OVT1	OVT0	00 _H
SRCR	W/R	101 _B	SLE7	SLE6	SLE5	SLE4	SLE3	SLE2	SLE1	SLE0	00 _H
STA	R	110 _B	OUT7	OUT6	OUT5	OUT4	OUT3	OUT2	OUT1	OUT0	00 _H
CTL	W/R	111 _B	OUT7	OUT6	OUT5	OUT4	OUT3	OUT2	OUT1	OUT0	00 _H

1) The default values are set after reset.

5 Package Outlines SPIDER - TLE 7232G

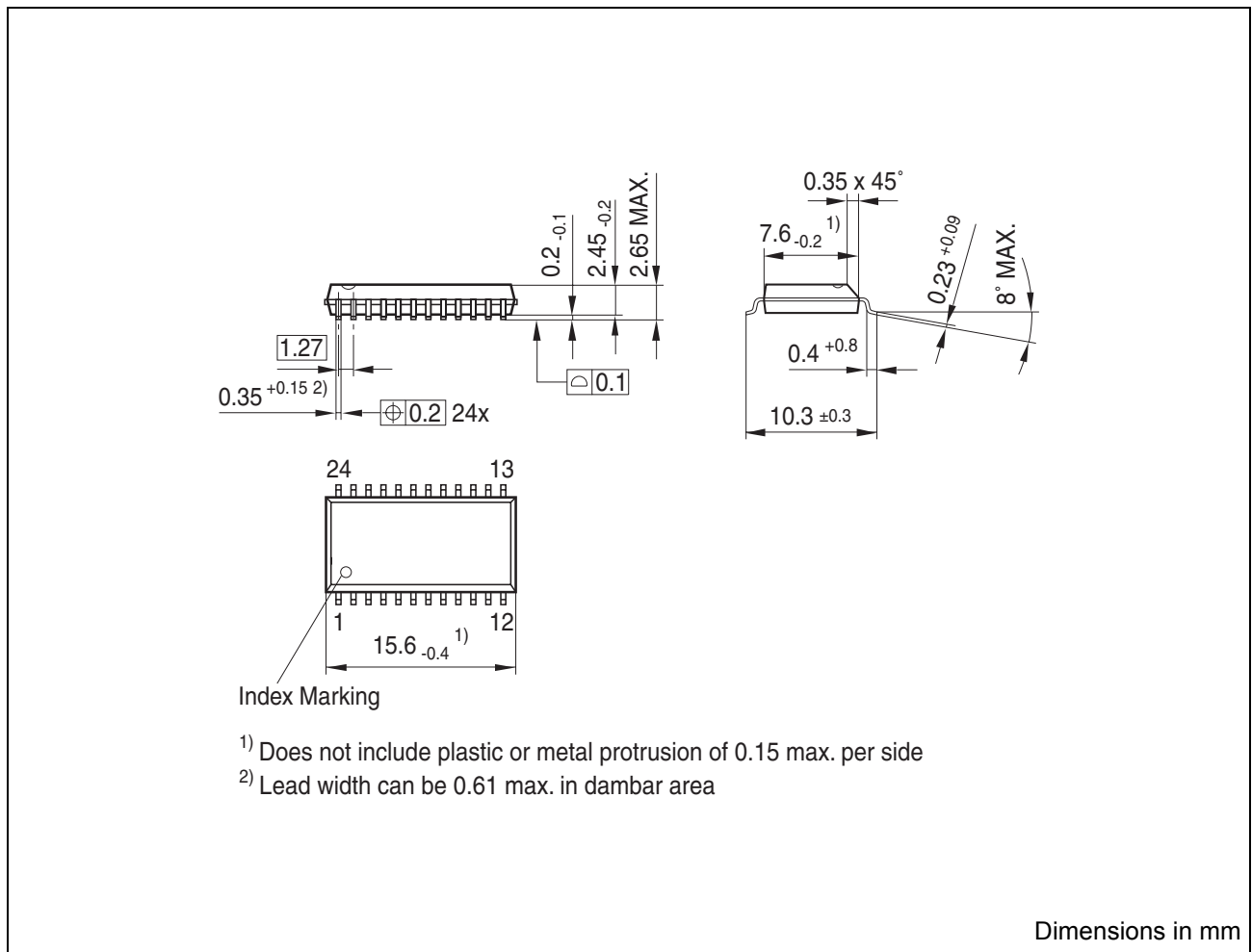

Figure 14 P-DSO-24-3 (Plastic Dual Small Outline Package)

You can find all of our packages, sorts of packing and others in our Infineon Internet Page "Products": <http://www.infineon.com/products>.

6 Revision History

Version	Date	Changes
V1.0	05-09-30	release of data sheet

Edition 2005-09-30

**Published by Infineon Technologies AG,
St.-Martin-Strasse 53,
D-81541 München, Germany**

**© Infineon Technologies AG 2005.
All Rights Reserved.**

Attention please!

The information herein is given to describe certain components and shall not be considered as warranted characteristics.

Terms of delivery and rights to technical change reserved.

We hereby disclaim any and all warranties, including but not limited to warranties of non-infringement, regarding circuits, descriptions and charts stated herein.

Infineon Technologies is an approved CECC manufacturer.

Information

For further information on technology, delivery terms and conditions and prices please contact your nearest Infineon Technologies Office in Germany or our Infineon Technologies Representatives worldwide.

Warnings

Due to technical requirements components may contain dangerous substances. For information on the types in question please contact your nearest Infineon Technologies Office.

Infineon Technologies Components may only be used in life-support devices or systems with the express written approval of Infineon Technologies, if a failure of such components can reasonably be expected to cause the failure of that life-support device or system, or to affect the safety or effectiveness of that device or system. Life support devices or systems are intended to be implanted in the human body, or to support and/or maintain and sustain and/or protect human life. If they fail, it is reasonable to assume that the health of the user or other persons may be endangered.

<http://www.infineon.com>

Published by Infineon Technologies AG