

# Smart Quad Channel Low-Side Switch

## Features

- Low ON-resistance 2 x 0.2 Ω , 2 x 0.35 Ω (typ.)
- Power - SO 20 - Package with integrated cooling area
- Overload shutdown
- Selective thermal shutdown
- Status monitoring
- Overvoltage protection
- Shorted circuit protection
- Standby mode with low current consumption
- μC compatible input
- Electrostatic discharge (ESD) protection

## Product Summary

Supply voltage	$V_S$	4.8 - 32	V
Drain source voltage	$V_{DS(AZ)max}$	60	V
On resistance	$R_{ON(typ) 1,2}$	0.2	Ω
	$R_{ON(typ) 3,4}$	0.35	Ω
Output current	$I_D 1,2$	2 x 5	A
	$I_D 3,4$	2 x 3	A



## Application

- All kinds of resistive and inductive loads (relays, electromagnetic valves)
- μC compatible power switch for 12 and 24 V applications
- Solenoid control switch in automotive and industrial control systems

## General description

Quad channel Low-Side-Switch (2x5A/2x3A) in Smart Power Technology (SPT) with four separate inputs and four open drain DMOS output stages. The TLE 6216 is fully protected by embedded protection functions and designed for automotive and industrial applications.

## Block diagram

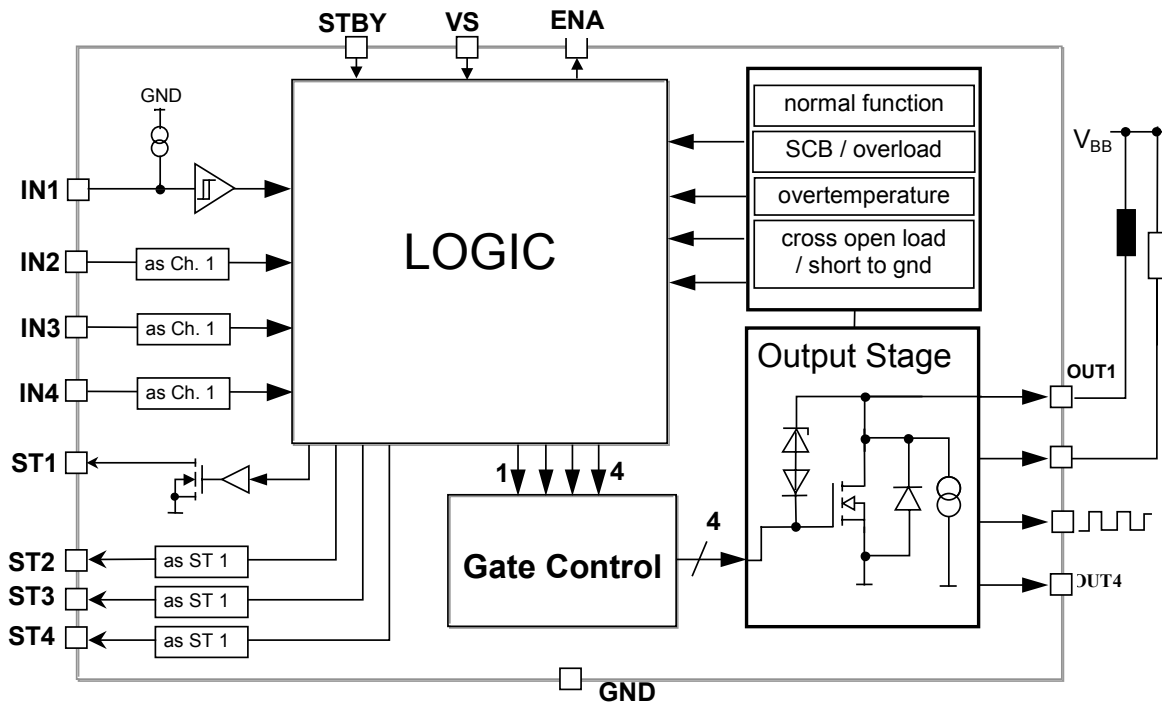

### Pin Configuration (Top view)

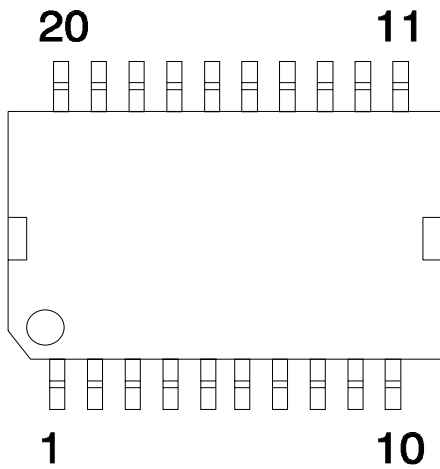

P - DSO - 20 - 12

### Pin Description

Pin	Symbol	Function
1	GND	Ground
2	OUT1	Power Output channel 1
3	ST1	Status Output channel 1
4	IN4	Control Input channel 4
5	VS	Supply Voltage
6	STBY	Standby
7	IN3	Control Input channel 3
8	ST2	Status Output channel 2
9	OUT2	Power Output channel 2
10	GND	Ground
11	GND	Ground
12	OUT3	Power Output channel 3
13	ST3	Status Output channel 3
14	IN2	Control Input channel 2
15	GND	Ground Logic
16	ENA	Enable Input for all four channels
17	IN1	Control Input channel 1
18	ST4	Status Output channel 4
19	OUT4	Power Output channel 4
20	GND	Ground

Heat slug internally connected to ground pins

### Detailed Block Diagram

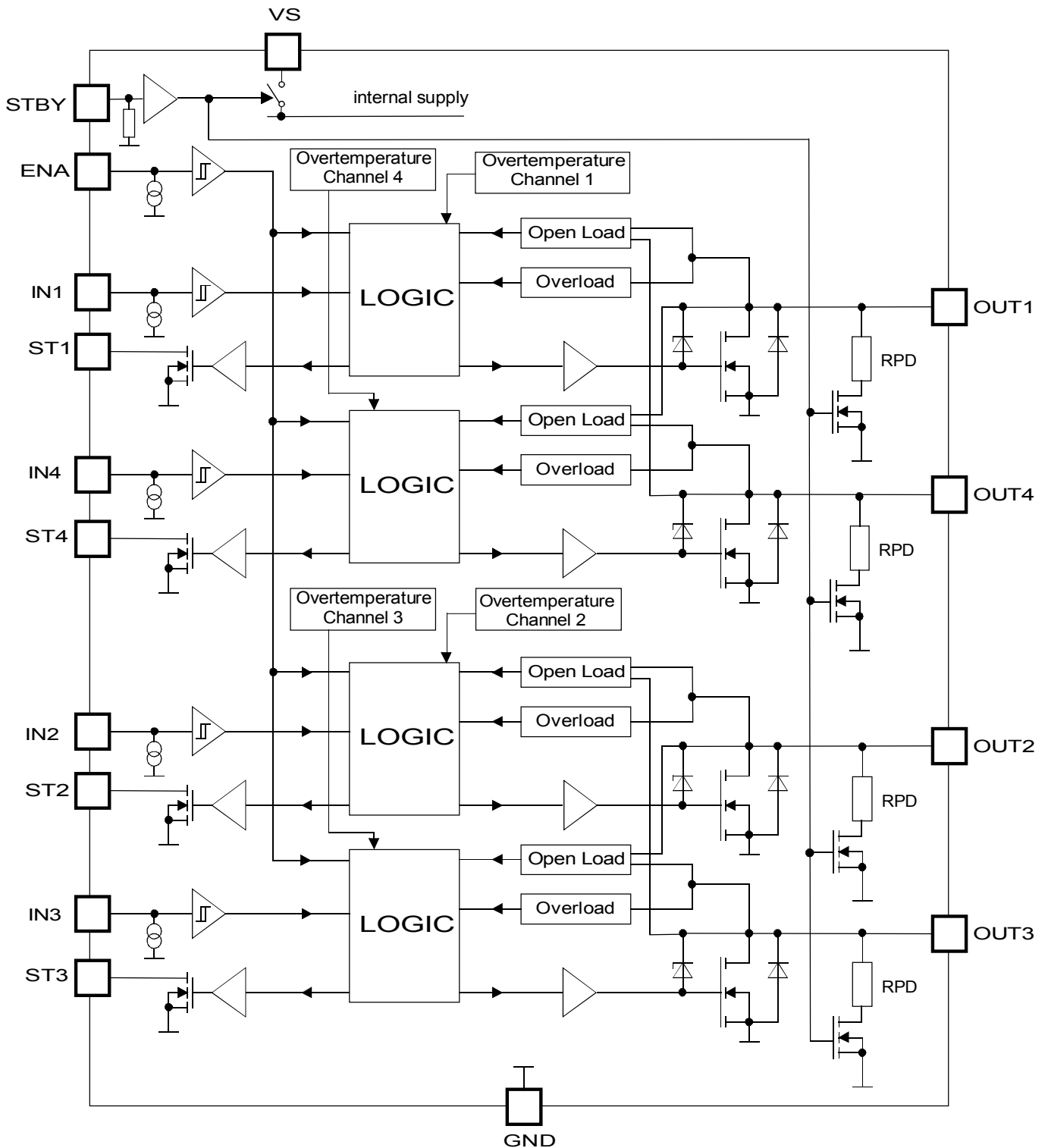

### Block Diagram of Open Load Detection

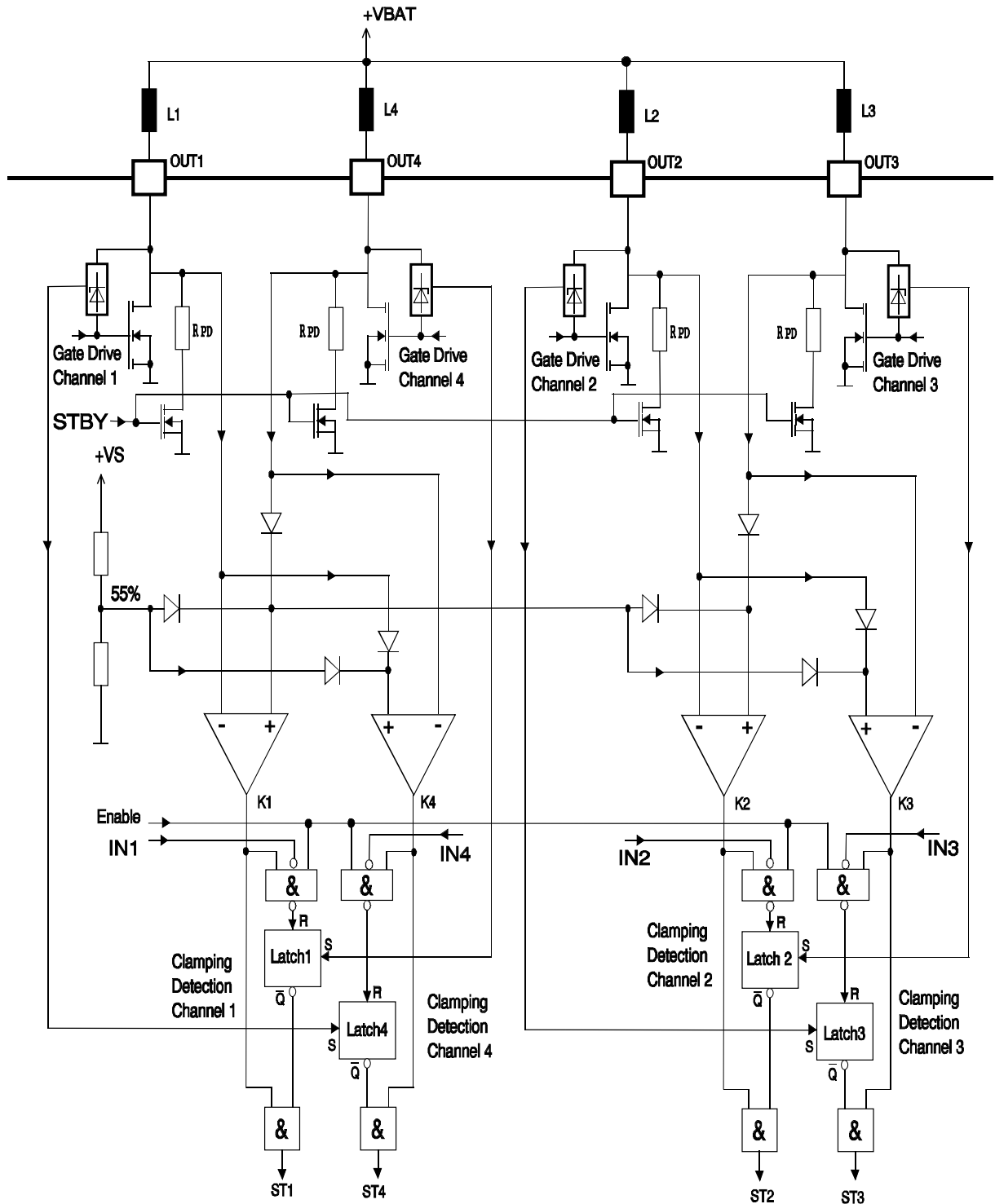

**Maximum Ratings for  $T_j = -40^{\circ}\text{C}$  to  $150^{\circ}\text{C}$** 

Parameter	Symbol	Values	Unit
Supply voltage	$V_S$	-0.3 ... + 40	V
Supply voltage operational range	$V_S$	+ 4.8 ... + 32	V
Continuous drain source voltage (OUT1...OUT4)	$V_{DS}$	40	V
Input voltage IN1 to IN4, ENA $I_i <  10  \text{ mA}$	$V_{IN}, V_{ENA}$	- 0.3 ... + 6 -1.5...+6	V
Input voltage STBY	$V_{STBY}$	- 0.3 ... + 40	V
Status output voltage	$V_{ST}$	- 0.3 ... + 32	V
Operating temperature range	$T_j$	- 40 ... + 150	$^{\circ}\text{C}$
during clamping; $\Sigma t = 30 \text{ min}$	$T_j$	175	
during clamping; $\Sigma t = 15 \text{ min}$	$T_j$	190	
Storage temperature range	$T_{stg}$	- 55 ... + 150	
Output current per channel	$I_{D(lim)}$	overload shutdown	A
Output current at reversal supply	$I_{D 1,2}$ $I_{D 3,4}$	- 4 - 2	A
Status output current	$I_{ST}$	- 5 ... + 5	mA
Inductive load switch off dissipation energy $T_j = 25^{\circ}\text{C}$	$E_{AS}$	50	mJ
Electrostatic Discharge Voltage (HBM) according to MIL STD 883D, method 3015.7 and EOS/ESD assn. Standard S5.1 – 1993 Output 1-4 Pins All other Pins	$V_{ESD}$	4000	V
	$V_{ESD}$	2000	V
Thermal resistance junction - case	$R_{thJC}$	2	K/W
Maximum operating lifetime (according to "Ambient thermal conditions")	$t_b$	10000	h

**Ambient thermal conditions**

$T_{Ambient}$ temperature range	operating periods
-40 $^{\circ}\text{C}$	2 %
-20 $^{\circ}\text{C}$	10 %
25 $^{\circ}\text{C}$	24 %
60 $^{\circ}\text{C}$	34 %
80 $^{\circ}\text{C}$	24 %
100 $^{\circ}\text{C}$	5 %
> 120 $^{\circ}\text{C}$	1 %

## Electrical Characteristics

Parameter and Conditions $V_S = 4.8$ to $18$ V ; $T_j = -40$ °C to $+150$ °C (unless otherwise specified)	Symbol	Values			Unit
		min	typ	max	

### 1. Power Supply ( $V_S$ )

Supply current (Outputs ON)	$I_S$			8	mA
Supply current (Outputs OFF) $V_{ENA} = L, V_{STBY} = H$	$I_S$			4	mA
Operating voltage	$V_S$	4.8		32	V
Standby current $V_{STBY} = L$	$I_S$			10	$\mu$ A

### 2. Power Outputs

ON state resistance Channel 1,2 $I_D = 1$ A; $V_S \geq 9.5$ V	$T_j = 25$ °C $T_j = 125$ °C <sup>1</sup> $T_j = 150$ °C <sup>2</sup>	$R_{DS(ON)}$		0.2	0.5 0.5	$\Omega$
ON state resistance Channel 3,4 $I_D = 1$ A; $V_S \geq 9.5$ V	$T_j = 25$ °C $T_j = 125$ °C <sup>1</sup> $T_j = 150$ °C <sup>2</sup>	$R_{DS(ON)}$		0.35	0.75 0.75	$\Omega$
Z-Diode clamping voltage (OUT1...4) $I_D \geq 100$ mA		$V_{DS(AZ)}$	45		60	V
Pull down resistor $V_{STBY} = H, V_{IN} = L$	$T_j = 25$ °C $T_j = -40$ °C ... $150$ °C	$R_{PD}$	14 10	20	26 40	k $\Omega$
Output Leakage Current $V_{STBY} = L$ $T_j = -40$ °C... $150$ °C wafer test at $25$ °C		$I_{Dik}$			5 1	$\mu$ A $\mu$ A
Output on delay time <sup>3</sup>	$I_D = 1$ A	$t_{on}$	0	5	25	$\mu$ s
Output off delay time <sup>3</sup>	$I_D = 1$ A	$t_{off}$	5		40	
Output on fall time <sup>3</sup>	$I_D = 1$ A	$t_{fall}$	5		50	
Output off rise time <sup>3</sup>	$I_D = 1$ A	$t_{rise}$	5		50	
Output off status delay time <sup>3</sup>	$I_D = 1$ A	$t_4$	10		60	
Output on status delay time <sup>4</sup>		$t_5$			50	
Overload switch-off delay time		$t_{DSO}$	50	100	300	

### 3. Digital Inputs (IN1, IN2, IN3, IN4, ENA)

Input low voltage		$V_{INL}$	- 0.3		1.0	V
Input high voltage		$V_{INH}$	2.0		6.0	V
Input voltage hysteresis <sup>4</sup>		$V_{INHys}$	50	100		mV
Input pull down current $V_{IN} = 5$ V; $V_S \geq 6.5$ V		$I_{IN}$	10	30	60	$\mu$ A
Enable pull down current $V_{ENA} = 5$ V; $V_S \geq 6.5$ V		$I_{ENA}$	10	20	40	$\mu$ A

### 4. Digital Status Outputs (ST1 - ST4) open Drain

Output voltage low $I_{ST} = 2$ mA		$V_{STL}$			0.5	V
Leakage current high		$I_{STH}$			2	$\mu$ A

<sup>1</sup> Measured on P-DSO-20 devices

<sup>2</sup> Measured on chip, bond wires not included

<sup>3</sup> See timing diagram, resistive load condition;  $V_S \geq 9$  V

<sup>4</sup> This parameter will not be tested but assured by design

## Electrical Characteristics

Parameter and Conditions $V_S = 4.8$ to $18$ V ; $T_j = -40$ °C to $+150$ °C (unless otherwise specified)	Symbol	Values			Unit
		min	typ	max	

### 5. Standby Input (STBY)

Input low voltage	$V_{STBY}$	0		1	V
Input high voltage	$V_{STBY}$	3.5		$V_S$	V
Input current	$V_{STBY} = 18$ V	$I_{STBY}$		300	$\mu$ A

### 6. Diagnostic Functions

Open load detection voltage $V_{ENA} = X, V_{IN} = L, V_{DC} = 0$ <sup>5</sup>	$V_S \geq 6.5$ V	$V_{DS(OL)}$	0.525		0.575	$*V_S$
Open load compare voltage $V_{ENA} = X, V_{IN} = L, 18V \geq V_{DSC} \geq V_{DS(OL)}$ <sup>5</sup>	$V_S \geq 6.5$ V	$V_{DS(OL)C}$	$V_{DSC}-1.5$		$V_{DSC}-1.0$	V
Open load current channel 1,2 $V_{ENA} = H, V_{IN} = H$	$V_S \geq 6.5$ V	$I_{D(OL) 1,2}$	160		480	mA
Open load current channel 3,4 $V_{ENA} = H, V_{IN} = H$	$V_S \geq 6.5$ V	$I_{D(OL) 3,4}$	160		480	mA
Overload threshold current channel 1,2	$V_S \geq 6.5$ V	$I_{D(lim) 1,2}$	5	7.5		A
Overload threshold current channel 3,4	$V_S \geq 6.5$ V	$I_{D(lim) 3,4}$	3	5		A
Overtemperature shutdown threshold <sup>6</sup> Hysteresis		$T_{th}$ $T_{hys}$	170	10	200	°C K

Table 1:

Channel	Compared with Channel
$V_{DS(OL) 1}$	4
$V_{DS(OL) 2}$	3
$V_{DS(OL) 3}$	2
$V_{DS(OL) 4}$	1

<sup>5</sup>  $V_{DSC}$  is the output voltage of the corresponding channel, paired for open load detection. Corresponding outputs are channel 1 and 4, channel 2 and 3 (see table 1).

<sup>6</sup> This parameter will not be tested but assured by design.

## Application Description

This IC is especially designed to drive inductive loads (relays, electromagnetic valves). Integrated clamp-diodes limit the output voltage when inductive loads are discharged.

Four open-drain logic outputs indicate the status of the integrated circuit. The following conditions are monitored and signaled:

- Overloading of output (also shorted load to supply) in active mode
- Open and shorted load to ground in active and inactive mode
- Overtemperature

## Circuit Description

### Input Circuits

The control and enable inputs, both active high, consist of schmitt triggers with hysteresis. All inputs are connected with pull-down current sources. Not connected inputs are interpreted as LOW.

In standby mode (STBY = LOW) the current consumption is greatly reduced. The circuit is active when STBY = HIGH.

If the standby function is not used, it is allowed to connect the standby pin directly to  $V_S$ .

### Switching Stages

The four power outputs consist of DMOS-power transistors with open drains. The output stages are shorted loads protected throughout the operating range. Integrated clamp-diodes limit voltage overshoots produced when inductive loads are demagnetized.

Parallel to the DMOS transistors there are internal pull down resistors. They are provided to detect an open load condition in the off state. They will be disconnected in the standby mode.

### Protective Circuits

The outputs are protected against current overload and overtemperature.

There is no protection against reverse polarity of the supply voltage.

### Error Detection

The status outputs indicate the switching state under normal conditions (LOW = off; HIGH = on). If an error occurs, the logic level of the status output is inverted, as listed in the diagnostic table below.

The state of the error detection circuits is directly dependent on the input status.

If current overload or overtemperature occurs, the error condition is stored into an internal register and the output is shutdown. The reset is done by switching off the corresponding control input.

Open load is detected for all four channels in on and off mode. In the on mode the load current is monitored. If it drops below the specified threshold value, then an open load condition is detected.



In the off mode, the output voltage is monitored.

An open load condition is detected when the output voltage of a given channel is below 55 % of the supply voltage  $V_s$ . Also the output voltages of two outputs are compared against each other in off condition with a fixed offset of typ. 1.25 V to recognize GND bypasses. To suppress fault diagnosis during the flyback phase of the compared output, the diagnostic circuit includes a latch function.

Reset of this latch is done at end of the flyback phase, additionally it can be reset by a low signal on the enable input or a high signal of the input line.

See block diagram of open load detection on page 4.

### Diagnostic Table

In general the status follows the input signal in normal operating conditions.

If any error is detected the status is inverted.

Operating Condition	Standby Input	Enable Input	Control Input	Power Output	Status Output
	<b>STBY</b>	<b>ENA</b>	<b>IN</b>	<b>OUT</b>	<b>ST</b>
Standby	L	X	X	OFF	H
Normal function	H	L	L	OFF	L
	H	L	H	OFF	L
	H	H	L	OFF	L
	H	H	H	ON	H
Open load or short to ground	H	L	L	OFF	H
	H	L	H	OFF	H
	H	H	L	OFF	H
	H	H	H	ON	L
Overload or short to supply latched overload	H	H	H	OFF	L
	H	H	H	OFF	L
	H	L	H	OFF	H
	H	X	H → L	OFF	L
Overtemperature	H	H	H	OFF	L
	H	H	H	OFF	L
	H	L	H	OFF	H
	H	X	H → L	OFF	L

### Diagnostic (continued)

The following diagrams show the dynamical behavior of the status output in case of different errors.

The symbol **F** defines the moment of failure occurrence.

#### Output open load or short circuit to GND

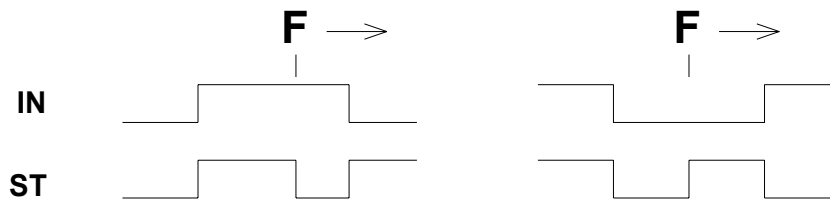

#### Output overload

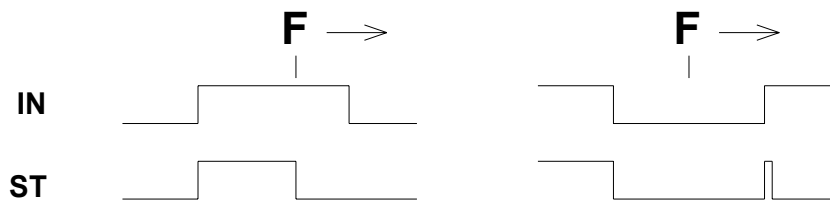

#### Overtemperature of the chip

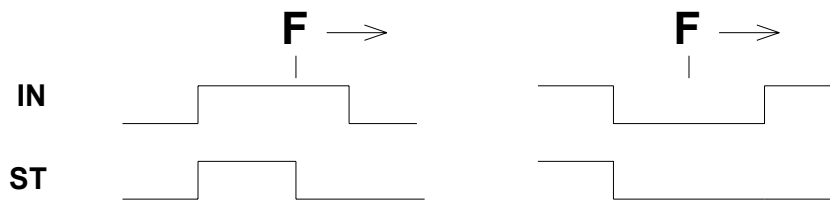

#### Load Bypass

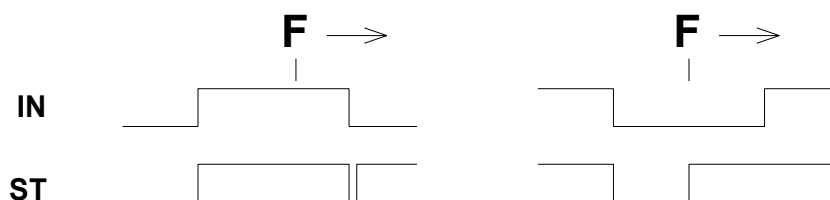

**Test Circuit**

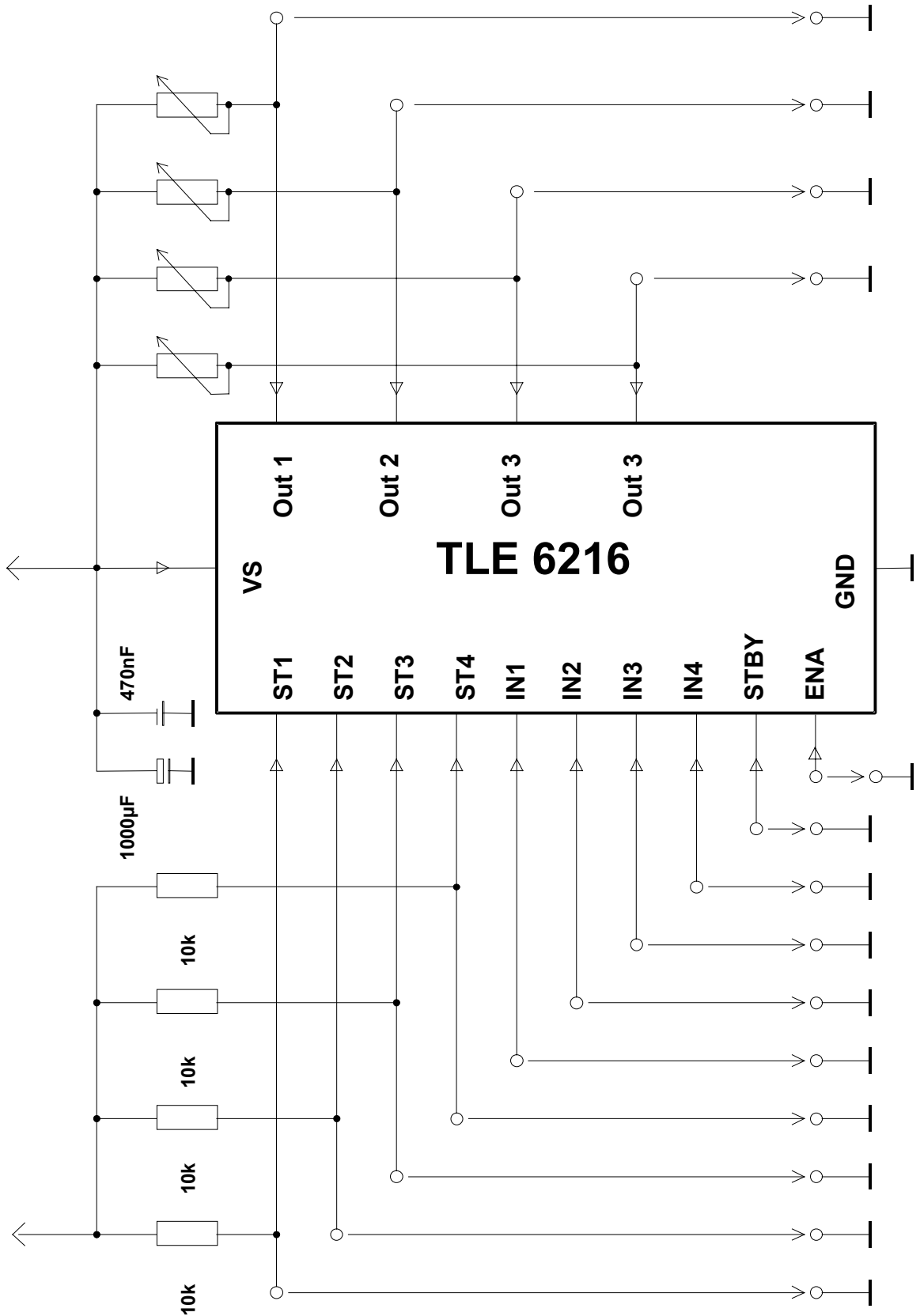

**Application Circuit**

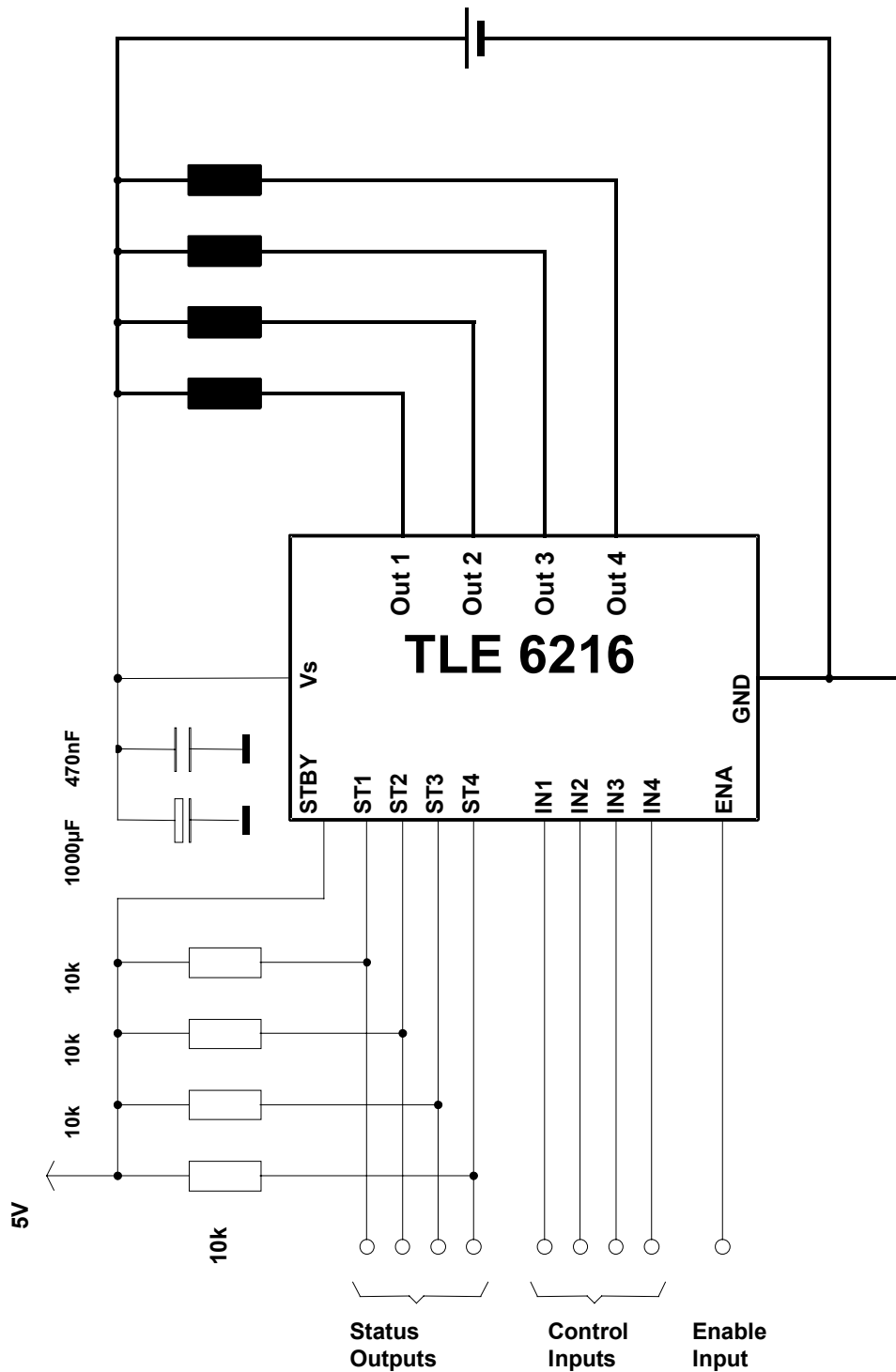

The blocking capacitor C is recommended to avoid critical negative voltage spikes on VS in case of battery interruption during OFF-commutation.

## Timing Diagrams

### Output Slope

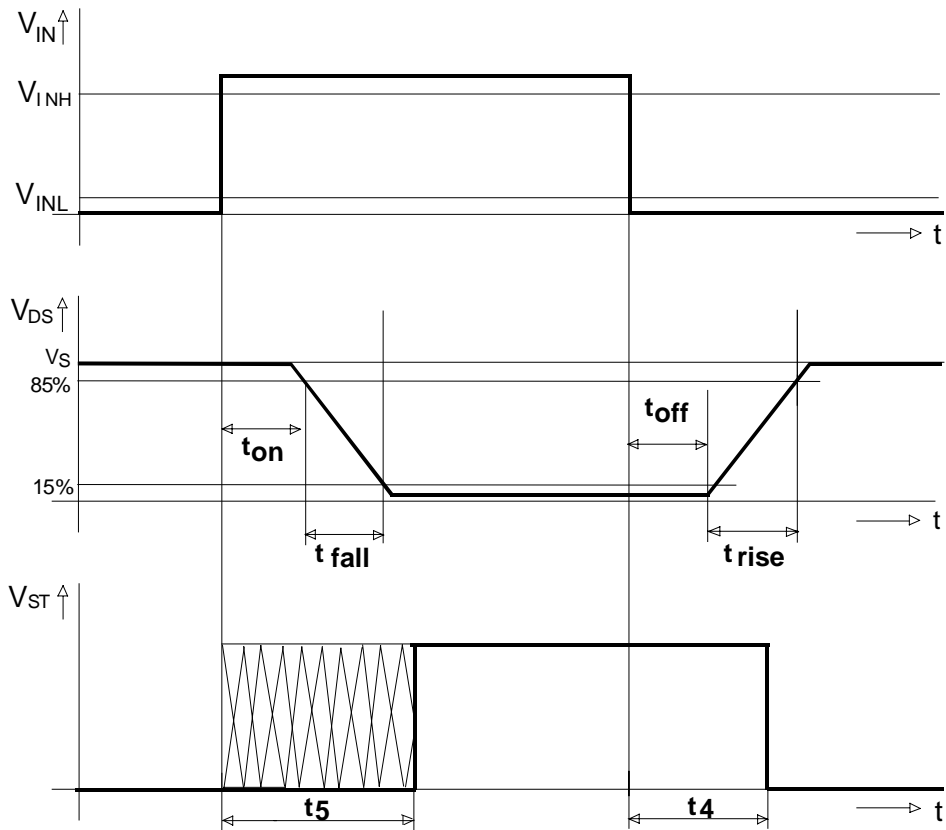

### Overload Switch OFF Delay

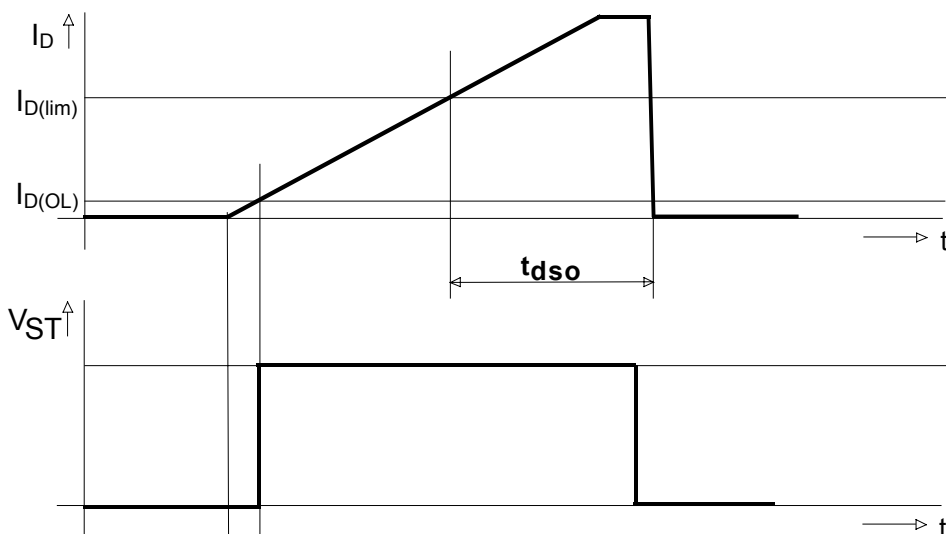

**Ordering code**

Type	Ordering Code	Package
TLE6216 G	on request	P - DSO - 20 – 12
TLE6216 C	on request	Bare dice on wafer

**Pad Assignment**

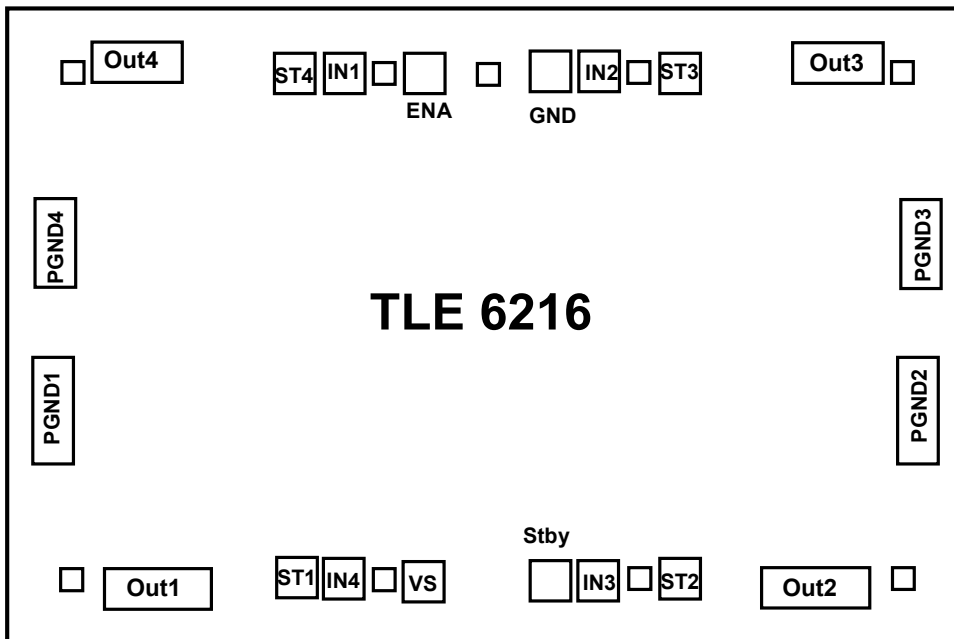

### Package dimensions

All dimensions in mm

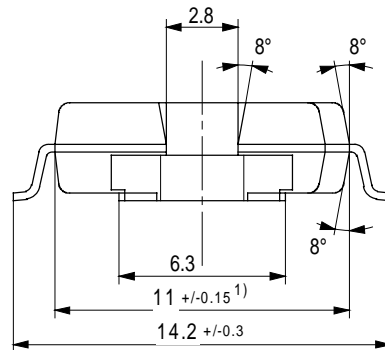
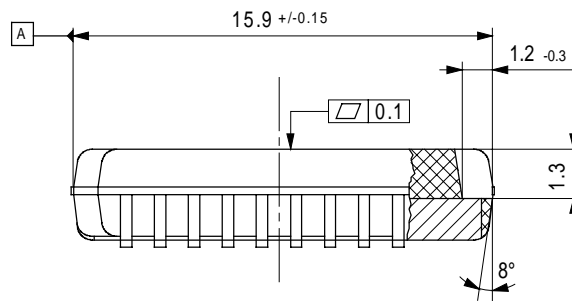
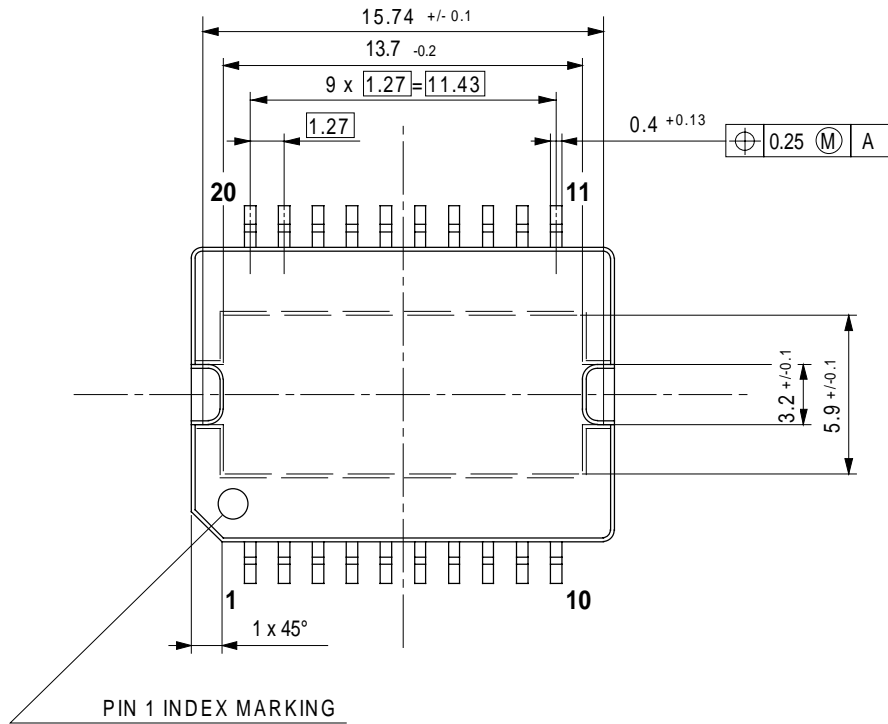

**Revision List:**

01.09.2001	Target Datasheet	V1
01.11.2001	First revision	V3
04.03.2002	Second revision	V4
30.04.2002	Third revision	V5
30.07.2002	Preliminary Datasheet	V6
09.09.2002	Final Datasheet	V7
18.10.02	Update typers	V7.1



**Published by  
Infineon Technologies AG,  
Bereich Kommunikation  
St.-Martin-Strasse 76,  
D-81541 München  
© Infineon Technologies AG 1999  
All Rights Reserved.**

**Attention please!**

The information herein is given to describe certain components and shall not be considered as warranted characteristics. Terms of delivery and rights to technical change reserved.  
We hereby disclaim any and all warranties, including but not limited to warranties of non-infringement, regarding circuits, descriptions and charts stated herein.  
Infineon Technologies is an approved CECC manufacturer.

**Information**

For further information on technology, delivery terms and conditions and prices please contact your nearest Infineon Technologies Office in Germany or our Infineon Technologies Representatives worldwide (see address list).

**Warnings**

Due to technical requirements components may contain dangerous substances. For information on the types in question please contact your nearest Infineon Technologies Office.

Infineon Technologies Components may only be used in life-support devices or systems with the express written approval of Infineon Technologies, if a failure of such components can reasonably be expected to cause the failure of that life-support device or system, or to affect the safety or effectiveness of that device or system. Life support devices or systems are intended to be implanted in the human body, or to support and/or maintain and sustain and/or protect human life. If they fail, it is reasonable to assume that the health of the user or other persons may be endangered.