

TLE4998C8(D)

High Performance Programmable Single/Dual Linear Hall Sensor

Data Sheet

Revision 1.1, 2017-01

Edition 2017-01

**Published by
Infineon Technologies AG
81726 Munich, Germany**

**© 2017 Infineon Technologies AG
All Rights Reserved.**

Legal Disclaimer

The information given in this document shall in no event be regarded as a guarantee of conditions or characteristics. With respect to any examples or hints given herein, any typical values stated herein and/or any information regarding the application of the device, Infineon Technologies hereby disclaims any and all warranties and liabilities of any kind, including without limitation, warranties of non-infringement of intellectual property rights of any third party.

Information

For further information on technology, delivery terms and conditions and prices, please contact the nearest Infineon Technologies Office (www.infineon.com).

Warnings

Due to technical requirements, components may contain dangerous substances. For information on the types in question, please contact the nearest Infineon Technologies Office.

Infineon Technologies components may be used in life-support devices or systems only with the express written approval of Infineon Technologies, if a failure of such components can reasonably be expected to cause the failure of that life-support device or system or to affect the safety or effectiveness of that device or system. Life support devices or systems are intended to be implanted in the human body or to support and/or maintain and sustain and/or protect human life. If they fail, it is reasonable to assume that the health of the user or other persons may be endangered.

Table of Contents

	Table of Contents	3
1	Overview	4
1.1	Features	4
1.2	Target Applications	5
1.3	Pin Configuration	5
2	General	6
2.1	Block Diagram	6
2.2	Functional Description	6
2.3	Principle of Operation	7
2.4	Transfer Functions	7
3	Maximum Ratings	8
4	Operating Range	9
5	Electrical, Thermal and Magnetic Parameters	10
5.1	Electrical Characteristics	10
5.2	Magnetic Characteristics	11
5.3	Electrical and Magnetic Characteristics in Undervoltage Range	12
5.4	Magnetic Field Direction Definition	12
6	Application Circuit	14
7	SPC Output	15
7.1	SPC Protocol	15
7.2	Unit Time Setup	16
7.3	Master Pulse	16
7.4	SPC Modes	18
7.4.1	Synchronous Transmission	18
7.4.2	Synchronous Transmission Including Range Selection	18
7.4.3	Synchronous Mode with ID Selection	19
8	Configuration and Calibration Parameters	21
9	Error Detection	23
9.1	Voltages Outside the Operating Range	23
9.2	EEPROM Error Correction	23
10	PG-TDSO-8 Package Outlines	24
10.1	Distance Chip to package	24
10.2	Moisture Sensitivity Level (MSL)	24
10.3	PG-TDSO-8 Package Marking	25

1 Overview



Characteristic	Supply Voltage	Supply Current	Magnetic Range	Interface	Temperature
Programmable Single/Dual Die Linear Hall Sensor	4.5~5.5 V	6 mA	±50mT ±100mT ±200mT	SPC (Short PWM Code) Open Drain Output	-40°C to 125°C



Figure 1-1 SMD package PG-TDSO-8 for the TLE4998C8(D)

1.1 Features

- Integration of two individual programmable Linear Hall sensor IC's with SPC (Short PWM Code) protocol with enhanced interface features based on SENT (Single Edge Nibble Transmission, defined by SAE J2716)
- 20-bit Digital Signal Processing (DSP)
- Digital temperature and stress compensation
- 16-bit overall resolution
- Operating automotive temperature range -40°C to 125°C
- Minimal drift of output signal over temperature and lifetime
- Programmable parameters stored in EEPROM with single-bit error correction:
 - SPC protocol modes: synchronous transmission, dynamic range selection, ID selection mode
 - Magnetic range, sensitivity (gain), offset, and polarity of the output slope
 - Bandwidth
 - Clamping levels
 - Customer temperature compensation coefficients for all common magnets
- Re-programmable until memory lock
- Supply voltage 4.5-5.5 V (4.1-16 V extended range)
- Configurable magnetic range: ±50 mT, ±100 mT, or ±200 mT
- Reverse-polarity and overvoltage protection for all pins
- Output short-circuit protection
- On-board diagnostics (overvoltage, EEPROM error)
- Output of internal magnetic field values and temperature
- Programming and operation of multiple sensors with common power supply
- Two-point calibration of magnetic transfer function without iteration steps

Note: Product qualification is based on "AEC Q100 Rev. G" grade 1 (Automotive Electronics Council - Stress test qualification for integrated circuits)

Table 1-1 Ordering Information

Product Name	Marking	Ordering Code	Package
TLE4998C8	C8S	SP000902764	single sensor, PG-TDSO-8-1
TLE4998C8D	C8D	SP000902768	dual sensor, PG-TDSO-8-2

1.2 Target Applications

- Robust replacement of potentiometers: No mechanical abrasion, resistant to humidity, temperature, pollution and vibration
- Linear and angular position sensing in automotive and industrial applications with highest accuracy requirements
- Suited for safety applications such as pedal position, throttle position and steering torque sensing

1.3 Pin Configuration

Figure 1-2 shows the location of the Hall elements in the package and the pin configuration of the TLE4998C8(D).

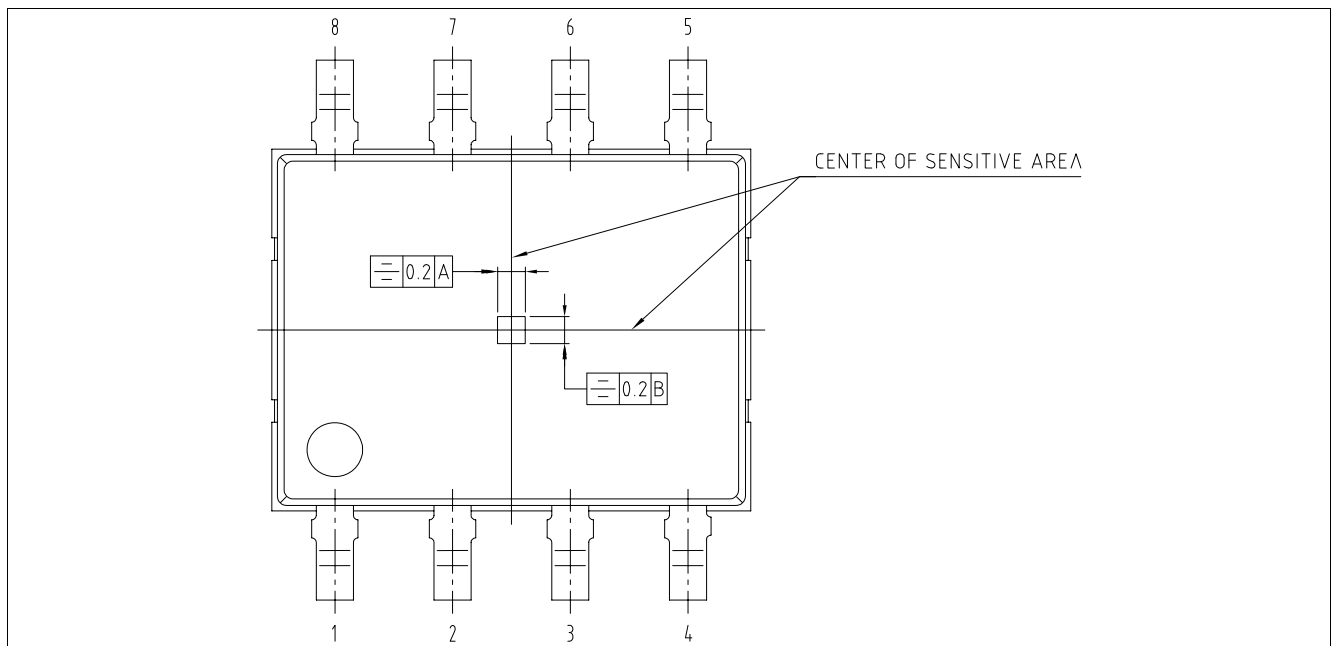

Figure 1-2 Pin Configuration of PG-TDSO-8 package

Table 1-2 TLE4998C8(D) Pin Definitions and Functions

Pin No.	Symbol	TLE4998C8 Function	TLE4998C8D Function
1	TST	Test pin (connection to GND is recommended)	Test pin (top die, connection to GND is recommended)
2	V_{DD}	Supply voltage / programming interface	Supply voltage / programming interface (top die)
3	GND	Ground	Ground (top die)
4	OUT	Output / programming interface	Output / programming interface (top die)
5	OUT	Not connected	Output / programming interface (bottom die)
6	GND	Not connected	Ground (bottom die)
7	V_{DD}	Not connected	Supply voltage / programming interface (bottom die)
8	TST	Not connected	Test pin (bottom die, connection to GND is recommended)

2 General

2.1 Block Diagram

Figure 2-1 shows is a simplified block diagram.

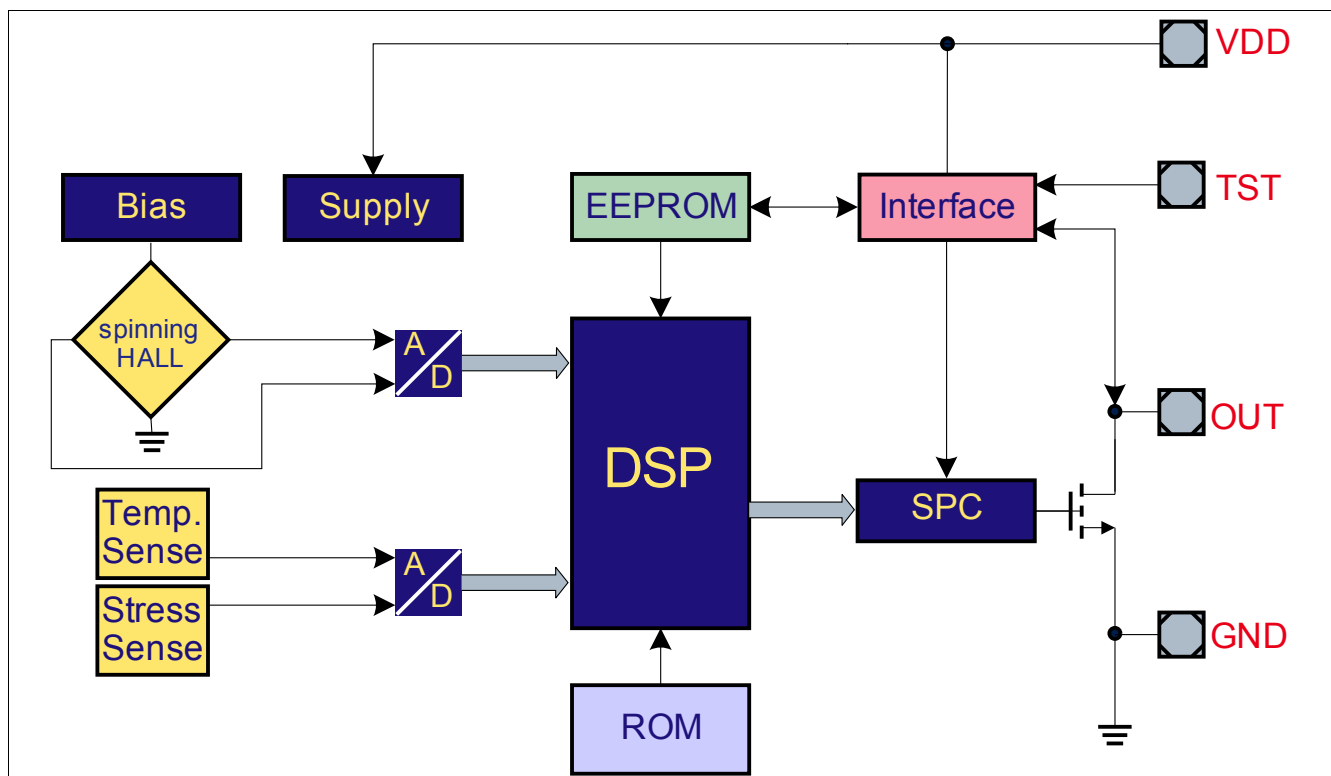

Figure 2-1 Block Diagram of the TLE4998C8(D) with the SPC interface

2.2 Functional Description

The linear Hall IC TLE4998C8(D) has been designed specifically to meet the requirements of highly accurate angle and position detection.

The sensor provides a digital SPC (Short PWM Code) signal, based on the standardized SENT (Single Edge Nibble Transmission, SAE J2716) protocol. The SPC protocol allows transmissions initiated by the ECU. Two further operation modes are available.

- “range selection” for dynamically switching of the measurement range during operation
- “ID selection” to build a bus system with up to 4 IC’s on a single output line and a common supply, which can be individually accessed by the ECU.

Each transmission sequence contains an adjustable number of nibbles representing the magnetic field, the temperature value and a status information of the sensor. The interface is further described in [Chapter 7](#).

The output stage is an open-drain driver pulling the output pin to low only. Therefore, the high level needs to be obtained by an external pull-up resistor. This output type has the advantage that the receiver may use an even lower supply voltage (e.g. 3.3 V). In this case the pull-up resistor must be connected to the given receiver supply.

The IC is produced in BiCMOS technology with high voltage capability and it also has reverse-polarity protection.

Digital signal processing using a 16-bit DSP architecture together with digital temperature and stress compensation guarantees excellent stability over the whole temperature range and life time.

2.3 Principle of Operation

- A magnetic flux is measured by a Hall-effect cell
- The output signal from the Hall-effect cell is converted from analog to digital signals
- The chopped Hall-effect cell and continuous-time A/D conversion ensure a very low and stable magnetic offset
- A programmable low-pass filter to reduce noise
- The temperature is measured and A/D converted
- Temperature compensation is done digitally using a second-order function
- Digital processing of the output value is based on zero field and sensitivity value
- The output value range can be clamped by digital limiters
- The final output value is represented by the data nibbles of the SPC protocol

2.4 Transfer Functions

The examples in **Figure 2-2** show how different magnetic field ranges can be mapped to the desired output value ranges.

- Polarity Mode:
 - **Bipolar**: Magnetic fields can be measured in both orientations. The limit points do not necessarily have to be symmetrical around the zero field point
 - **Unipolar**: Only north- or south-oriented magnetic fields are measured
- Inversion: Both gain can be set to positive values, negative values or positive/negative values.

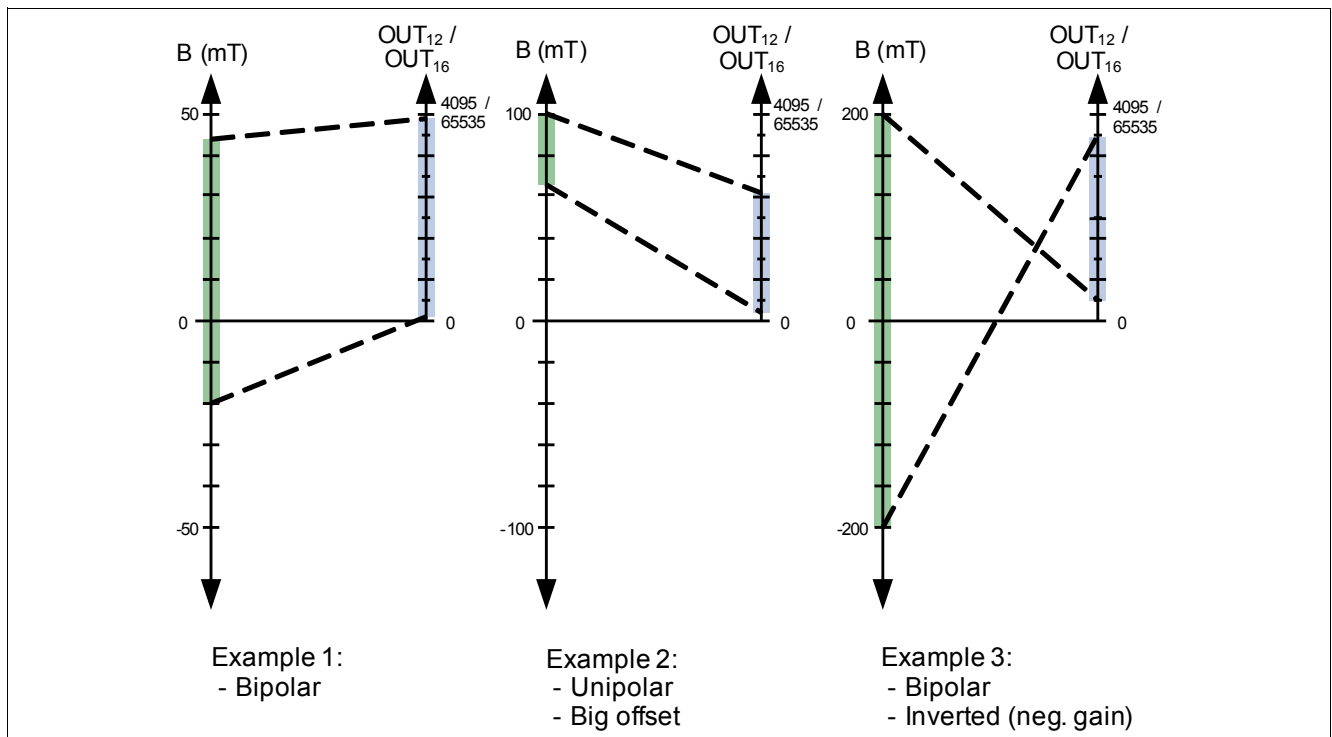

Figure 2-2 Examples of Operation

3 Maximum Ratings

All further given specifications are regarded to each of the implemented sensors IC's, or otherwise noted.

Table 3-1 Absolute Maximum Ratings

Parameter	Symbol	Values			Unit	Note / Test Condition
		Min.	Typ.	Max.		
Junction temperature	T_J	- 40	–	160 ¹⁾	°C	–
Voltage on V_{DD} pin with respect to ground	V_{DD}	-18	–	18.35	V	2)3)
Supply current @ overvoltage V_{DD} max.	I_{DDov}	–	–	15	mA	–
Reverse supply current @ V_{DD} min.	I_{DDrev}	-1	–	0	mA	–
Voltage on output pin with respect to ground	V_{OUT}	-1 ⁴⁾	–	18.35 ⁵⁾	V	–
Magnetic field	B_{MAX}	–	–	1	T	–
ESD protection	V_{ESD}	–	–	±2	kV	According HBM ANSI/ESDA/JEDEC JS-001

- 1) For limited time of 96 h. Depends on customer temperature lifetime cycles. Please ask Infineon for support.
- 2) Higher voltage stress than absolute maximum rating, e.g. 150% in latch-up tests is not applicable. In such cases, $R_{series} \geq 100 \Omega$ for current limitation is required.
- 3) Max 1h, in operating temperature range.
- 4) I_{DD} can exceed 10 mA when the voltage on OUT is pulled below -1 V (-5 V at room temperature).
- 5) $V_{DD} = 5 V$, open drain permanent low, for max. 10 minutes

Attention: Stresses above those listed under “Absolute Maximum Ratings” may cause permanent damage to the device. This is a stress rating only and functional operation of the device at these or any other conditions above those indicated in the operational sections of this specification is not implied. Furthermore, only single error cases are assumed. More than one stress/error case may also damage the device.

Exposure to absolute maximum rating conditions for extended periods may affect device reliability. During absolute maximum rating overload conditions the voltage on VDD pins with respect to ground (VSS) must not exceed the values defined by the absolute maximum ratings. Lifetime statements are an anticipation based on an extrapolation of Infineon’s qualification test results. The actual lifetime of a component depends on its form of application and type of use etc. and may deviate from such statement. The lifetime statement shall in no event extend the agreed warranty period.

4 Operating Range

The following operating conditions must not be exceeded in order to ensure correct operation of the TLE4998C8(D). All parameters specified in the following sections refer to these operating conditions and each of the implemented sensors IC's if applicable or unless otherwise indicated.

Table 4-1 Operating Range

Parameter	Symbol	Values			Unit	Note / Test Condition
		Min.	Typ.	Max.		
Supply voltage	V _{DD}	4.5	–	5.5	V	–
		4.1	–	16 ¹⁾²⁾	V	Extended range
Supply undervoltage	V _{DDuv}	V _{DDpon} ³⁾	–	4.1	V	Undervoltage range, reduced magnetic performance (see Table 5-3)
Output pull-up voltage ⁴⁾	V _{pull-up}	–	–	18.35	V	–
Load resistance ⁴⁾	R _L	1	–	–	kΩ	–
Output current ⁴⁾	I _{out}	0	–	5	mA	–
Load capacitance ⁴⁾	C _L	1	–	8	nF	–
Ambient temperature ⁵⁾	T _A	-40	–	125	°C	max. 1200 h at 125°C ⁶⁾

- 1) For supply voltages > 12 V, a series resistance R_{series} ≥ 100 Ω is recommended
- 2) The open drain switch off, due to overvoltage on the V_{DD} line, can take place in the range of 16.65 V to 18.35 V, as defined in [Chapter 9.1](#) of the data sheet.
- 3) V_{DDpon} ... power-on reset level, see [Table 5-1](#)
- 4) Output protocol characteristics depend on these parameters, R_L must be according to max. output current
- 5) R_{THja} ≤ 150 K/W.
- 6) Maximum exposure time at other ambient temperatures between -40°C and 125°C shall be calculated based on the values specified in this table using the Arrhenius model.

Note: Keeping signal levels within the limits specified in this table ensures operation without overload conditions.

5 Electrical, Thermal and Magnetic Parameters

All specification values are valid over temperature and lifetime, unless noted otherwise.

5.1 Electrical Characteristics

Table 5-1 Electrical Characteristics

Parameter	Symbol	Values			Unit	Note / Test Condition
		Min.	Typ.	Max.		
Supply current	I_{DD}	3	6	8	mA	per die
Thermal resistance ¹⁾	R_{thJA}	–	150	–	K/W	junction to air
	R_{thJC}	–	85	–	K/W	junction to case
Power-on time ²⁾	t_{Pon}	–	0.7	2	ms	$\leq \pm 5\%$ target out value
		–	15	20		$\leq \pm 1\%$ target out value
Power-on reset level ³⁾	V_{DDpon}	3.1	3.5	3.9	V	
Output impedance	Z_{OUT}	20	40	70	k Ω	
Output fall time	t_{fall}	2	3.5	5	μ s	V_{OUT} 4.5 V to 0.5 V ⁴⁾
Output rise time	t_{rise}	–	20	–	μ s	V_{OUT} 0.5 V to 4.5 V ⁴⁾
Output low saturation voltage	V_{OUTsat}	–	0.3	0.6	V	$I_{OUTsink} = 5$ mA
		–	0.2	0.4	V	$I_{OUTsink} = 2.2$ mA
Output noise (rms)	OUT_{noise}	–	–	2	LSB ₁₂	With LP filter setting from 80 Hz until 1390 Hz ⁵⁾
Oscillator frequency variation	$\Delta f / f$	-20	–	20	%	Nominal oscillator frequency: 8MHz

- 1) Values derived from a simulation with a 4-layer PCB
- 2) Response time to set up output data at power on when a constant field is applied. The first value given has a $\pm 5\%$ error, the second value has a $\pm 1\%$ error.
- 3) Power-on and power-off
- 4) Depends on External R_L and C_L , See [Figure 5-1](#)
- 5) Range ± 50 mT (also valid for ranges ± 100 mT and ± 200 mT), Gain 1.0 (scales linearly with gain)

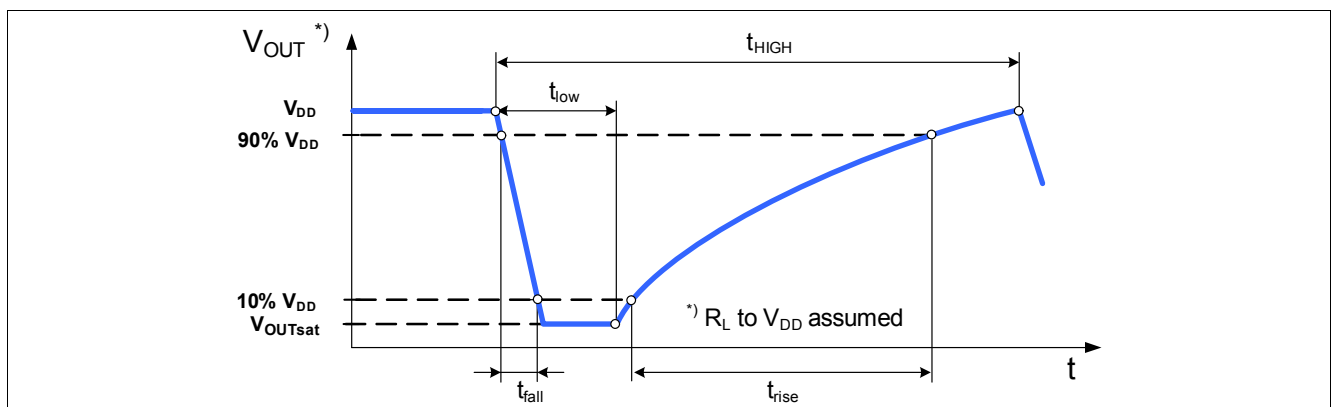

Figure 5-1 Output Characteristic

Calculation of the Junction Temperature

The internal power dissipation P_{TOT} of the sensor increases the chip junction temperature above the ambient temperature.

The power multiplied by the total thermal resistance R_{thJA} (Junction to Ambient) added to T_A leads to the final junction temperature. R_{thJA} is the sum of the addition of the two components, Junction to Case and Case to Ambient.

$$R_{thJA} = R_{thJC} + R_{thCA}$$

$$T_J = T_A + \Delta T = R_{thJA} \times P_{TOT} = R_{thJA} \times (V_{DD} \times I_{DD} + V_{OUT} \times I_{OUT}); I_{DD}, I_{OUT} > 0, \text{ if direction is into IC}$$

Example (assuming no load on V_{OUT} and TLE4998C8(D) type):

- $V_{DD} = 5 \text{ V}$
- $I_{DD} = 8 \text{ mA}$
- $\Delta T = 150 \text{ [K/W]} \times (5 \text{ [V]} \times 0.008 \text{ [A]} + 0 \text{ [VA]}) = 6 \text{ K per silicon}$

For molded sensors, the calculation with R_{thJC} is more adequate.

5.2 Magnetic Characteristics
Table 5-2 Magnetic Characteristics

Parameter	Symbol	Values			Unit	Note / Test Condition
		Min.	Typ.	Max.		
Sensitivity	$S^{1)}$	± 8.2	–	± 245	LSB ₁₂ /mT	programmable ²⁾
Sensitivity drift	ΔS	-2.0	–	+2.0	%	
Magnetic field range	MFR	± 50	± 100	± 200	mT	programmable ³⁾
Integral nonlinearity	INL	–	± 2.0	± 4.1	LSB ₁₂	⁴⁾
Magnetic offset	B_{OS}	–	± 100	± 400	μT	
Magnetic offset drift	ΔB_{OS}	–	± 1	± 5	$\mu\text{T}/^\circ\text{C}$	
Magnetic hysteresis	B_{HYS}	–	–	20 10	μT	in 50mT range in 100mT range

1) Defined as $\Delta OUT / \Delta B$.

2) Programmable in steps of 0.024%.

3) Depending on offset and gain settings, the output may already be saturated at lower fields.

4) Range $\pm 50 \text{ mT}$ (also valid for ranges $\pm 100 \text{ mT}$ and $\pm 200 \text{ mT}$), Gain = 1.0 (scales linearly with gain)

5.3 Electrical and Magnetic Characteristics in Undervoltage Range

Table 5-3 Electrical and Magnetic Characteristics in Supply Undervoltage Range

Parameter	Symbol	Values			Unit	Note / Test Condition
		Min.	Typ.	Max.		
Sensitivity drift	$S_{E(T)}$	–	–	+2.5/-7.5	%	
Magnetic offset drift	ΔB_{OS}	–	–	± 400	μT	
Integral nonlinearity	INL	–	–	± 8.2	LSB ₁₂	1)
Output noise (rms)	OUT _{noise}	–	–	8	LSB ₁₂	With LP filter setting from 80 Hz until 1390 Hz ¹⁾

1) Range ± 50 mT (also valid for ranges ± 100 mT and ± 200 mT), Gain = 1.0 (scales linearly with gain)

5.4 Magnetic Field Direction Definition

Figure 5-2 shows the definition of the magnetic field direction. By standard the south pole field defines the positive field values of the top die of the TLE4998C8(D).

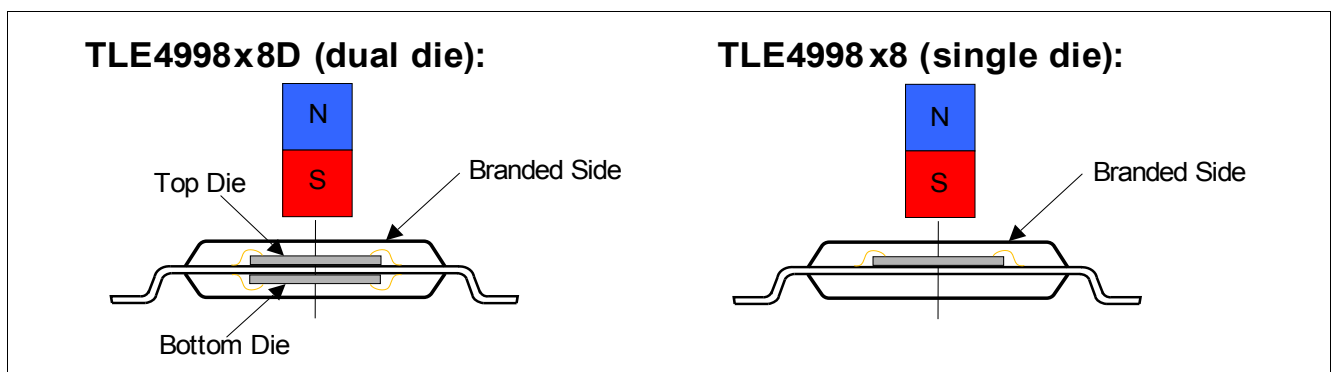

Figure 5-2 Definition of magnetic field direction of the TLE4998C8(D).

For the TLE4998C8D, the bottom die measures the inverted field value of the top die. This leads to a default output characteristic as shown in Figure 5-3.

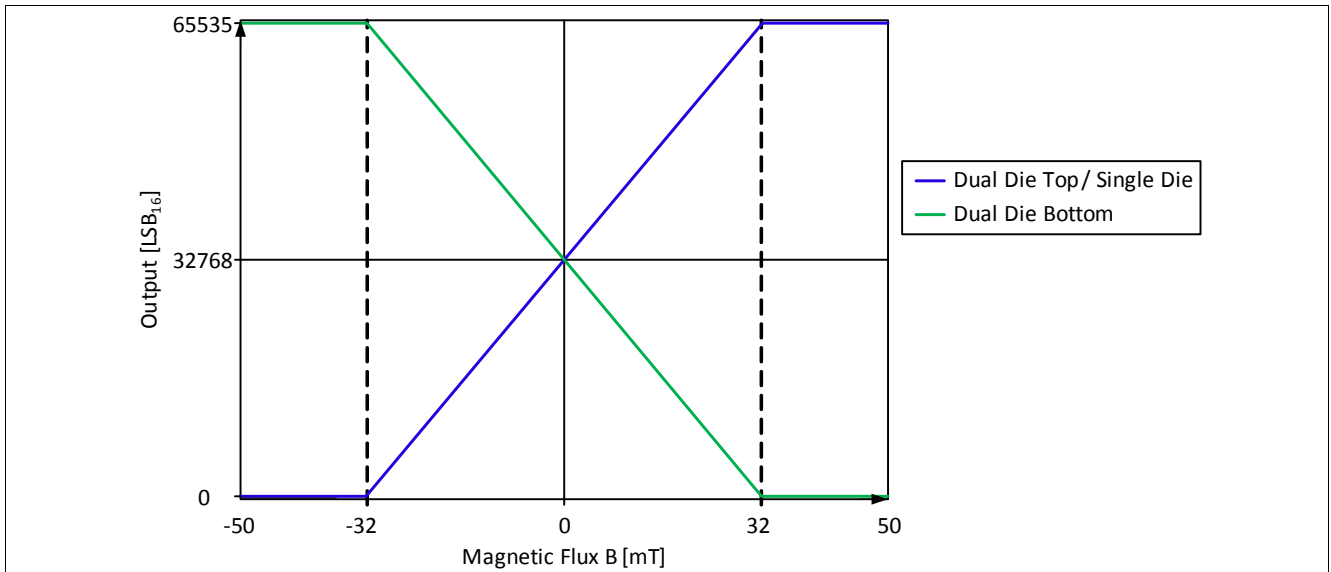

Figure 5-3 Example of the dual die output characteristic (range 50 mT, gain 1.0, typical)

6 Application Circuit

Figure 6-1 shows the connection of two Linear Hall sensors to a microcontroller.

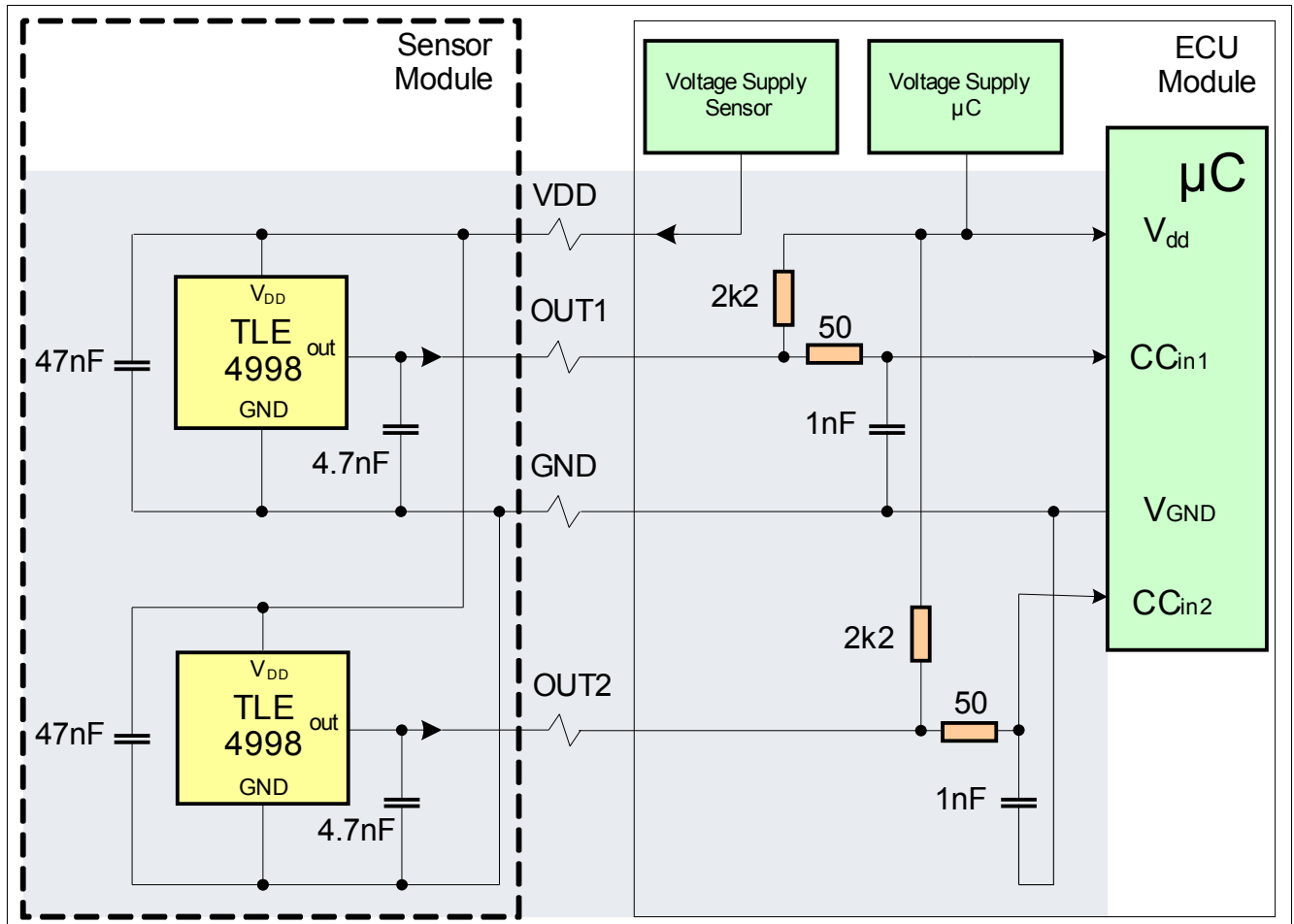

Figure 6-1 Application Circuit

The application circuit shown should be regarded as an example only.

7 SPC Output

The sensor supports a SPC (Short PWM Code) protocol, which enhances the standard SENT protocol (Single Edge Nibble Transmission) defined by SAE J2716. SPC is a synchronous SENT output, triggered by a master pulse from the ECU.

7.1 SPC Protocol

The single edge is defined by a 3 unit time (UT) low pulse on the output, followed by the high time defined in the protocol (nominal values, may vary by tolerance of internal RC oscillator and the programming, see [Chapter 7.2](#)). All values are multiples of a configurable unit time. A transfer consists of the following parts:

- A trigger pulse by the master, which initiates the data transmission
- A synchronization period of 56 UT (in parallel, a new sample is calculated)
- A status nibble of 12-27 UT
- Between 3 and 6 data nibbles of 12-27 UT each (number is programmable, see [Table 7-1](#)), representing the Hall value and temperature information
- A Checksum (CRC) nibble of 12-27 UT.
- An end pulse to terminate the SPC transmission.

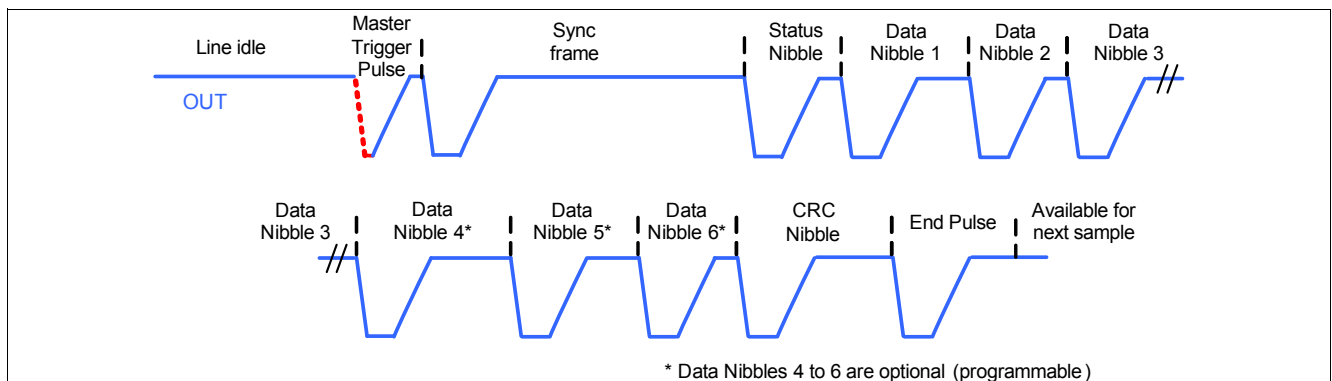

Figure 7-1 SPC Frame

The CRC checksum includes the status nibble and the data nibbles and can be used to check the validity of the decoded data. It is calculated using a polynomial $x^4 + x^3 + x^2 + 1$ with a seed value of 0101. The calculation scheme of the CRC is described in detail in the [TLE4998 User's Manual](#).

The sensor is available for the next sample 90 μ s after the falling edge of the end pulse. The sensor's sampling time is at the beginning of the synchronization period.

The number of transmitted SPC nibbles is programmable to customize the amount of information sent by the sensor. The default frame contains a 16 bit Hall value and an 8bit temperature value.

Table 7-1 Frame Selection

Frame Type	Parameter F	Data Nibbles
16 bit Hall, 8 bit temperature	0	6 nibbles
16 bit Hall	1	4 nibbles
12 bit Hall, 8 bit temperature	2	5 nibbles
12 bit Hall	3	3 nibbles

The temperature is coded as an 8 bit value. The value is transferred in unsigned integer format and corresponds to the range between -55 $^{\circ}$ C and +200 $^{\circ}$ C, so a transferred value of 55 corresponds to 0 $^{\circ}$ C. The temperature is additional information and although it is not calibrated, may be used for a plausibility check, for example. [Table 7-2](#) shows the mapping between junction temperature and the transmitted value in the SPC frame.

Table 7-2 Mapping of Temperature Value

Junction Temperature	Typ. Decimal Value from Sensor	Note
- 55 °C	0	Theoretical lower limit ¹⁾
0 °C	55	–
25 °C	80	–
200 °C	255	Theoretical upper limit ¹⁾

1) Theoretical range of temperature values, not operating temperature range.

The status nibble allows to check internal states and conditions of the sensor.

- Depending on the selected SPC mode, the first two bits of the status nibble contain either the selected magnetic range or the ID of the sensor and allow therefore an easy interpretation of the received data.
- The third bit is set to 1 for the first transmission after the sensor returns from an overvoltage operation with disabled open drain stage to regular operation (see [Chapter 9](#)).
- The fourth bit is switched to 1 for the first data package transferred after a reset.

7.2 Unit Time Setup

The basic SPC protocol unit time granularity is defined as 3 μs. Every timing is a multiple of this basic time unit. To achieve more flexibility, trimming of the unit time can be used to:

- Allow a calibration trim within a timing error of less than 20% clock error (as given in SAE standard)
- Allow a modification of the unit time for small speed adjustments

This enables a setup of different unit times. The output characteristic depends on the external load, the wiring, as well on the pull-up resistor and the temperature. Furthermore, sufficient driving capability of the receiver is required, in order to fulfill the master pulse requirements.

Table 7-3 Pre-divider Setting

Parameter	Symbol	Values			Unit	Note / Test Condition
		Min.	Typ.	Max.		
Unit time	t_{UNIT}	2.0	–	3.88	μs	$Clk_{UNIT}=8\text{ MHz}^{1)2)}$

1) Default setting is 3 μs nominal SPC unit time.

2) Subject to RC oscillator frequency variation ± 20%.

The nominal unit time is calculated by:

$$t_{UNIT} = (Prediv + 16) / Clk_{UNIT}$$

$$Clk_{UNIT} = 8\text{MHz} \pm 20\% \tag{7.1}$$

7.3 Master Pulse

An SPC transmission is initiated by a Master pulse from the ECU on the OUT pin. To detect a low-level on the OUT pin, the voltage has to be below a threshold V_{thr} . The sensor detects that the OUT line has been released as soon as V_{thr} is crossed. [Figure 7-2](#) shows the timing definitions for the master pulse. The master low time $t_{m\text{low}}$ as well as the total trigger time $t_{m\text{tr}}$ are individual for the different SPC modes and are given in the subsequent sections.

It is recommended to choose the typical master low time exactly between the minimum and the maximum possible time: $t_{m\text{low,typ}} = (t_{m\text{low,min}} + t_{m\text{low,max}}) / 2$. The master shall provide a high timing accuracy (approx. 1%). If the master low time exceeds the maximum low time, the sensor does not respond and is available for a next triggering 30μs

after the master pulse crosses V_{thr} . $t_{md,tot}$ is the delay between internal triggering of the falling edge in the sensor and the triggering of the ECU.

Note: Internal acceptance limits for trigger low time are wider than those specified in [Table 7-6](#), [Table 7-7](#), and [Table 7-8](#), to accommodate $\pm 20\%$ oscillator drift.

Table 7-4 Master Pulse Parameters

Parameter	Symbol	Values			Unit	Note / Test Condition
		Min.	Typ.	Max.		
Falling edge threshold	V_{thf}	1.1	1.3	1.7	V	–
Rising edge threshold	V_{thr}	1.25	1.43	1.8	V	–
Total trigger time	t_{mtr}	–	13	–	UT	Synchronous mode ¹⁾²⁾
		–	56	–	UT	Dyn. range mode ¹⁾²⁾
		–	90	–	UT	ID selection mode ¹⁾²⁾
Master delay time	$t_{md,tot}$	3.7	5.8	7.9	μs	³⁾

- 1) UT = Programmed nominal SPC unit time
- 2) Trigger time in the sensor is fixed to the number of unit times specified in the “typ.” column, but the effective trigger time varies due to the sensor’s clock variation
- 3) Depends on External R_L , C_L and V_{dd}

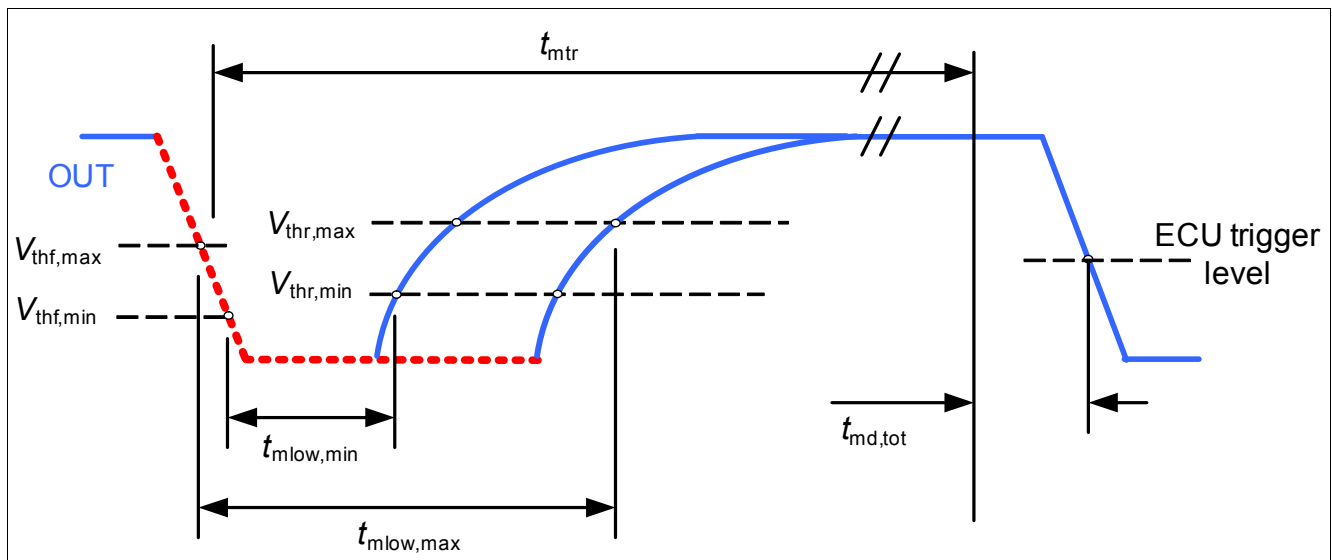

Figure 7-2 SPC Master Pulse Timing

7.4 SPC Modes

SPC enables the use of enhanced protocol functionality due to the ability to select between “synchronous”, “range selection” and “ID selection” protocol mode. The ID register is only used in ID selection mode.

Table 7-5 SPC Mode Selection

Mode	Parameter Prot MSB	Parameter Prot LSB
Synchronous	0	No effect
Dynamic range selection	1	0
ID selection	1	1

7.4.1 Synchronous Transmission

In the “synchronous” mode, the sensor (slave) starts to transfer a complete data frame only after a low pulse is forced by the master on the OUT pin. This means that the data line is bidirectional - an open drain output of the micro controller (master) sends the trigger pulse. The sensor then initiates a sync pulse and starts to calculate the new output data value. After the synchronization period, the data follows in form of a standard SENT frame, starting with the status, data and CRC nibbles. At the end, an end pulse allows the CRC nibble decoding and indicates that the data line is idle again. The timing diagram in [Figure 7-1](#) visualizes a synchronous transmission.

Table 7-6 Master Pulse Timing for Synchronous Mode

Parameter	Symbol	Values			Unit	Note / Test Condition
		Min.	Typ.	Max.		
Master low time	$t_{m\text{low}}$	1.5	2.75	4	UT ¹⁾	–

1) UT = Programmed nominal SPC unit time.

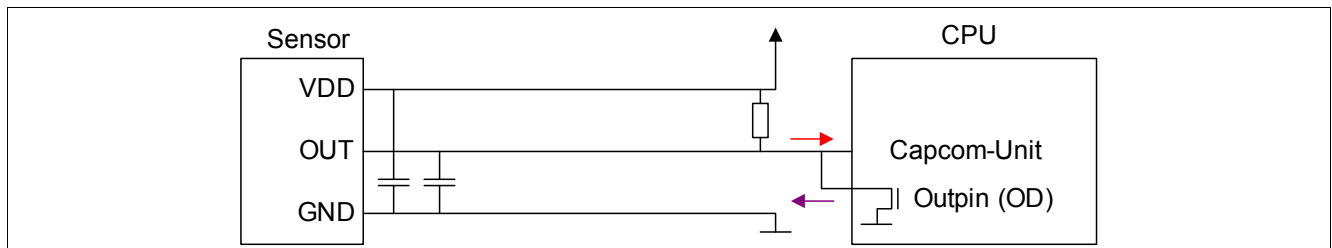

Figure 7-3 Bidirectional Communication in Synchronous Mode

7.4.2 Synchronous Transmission Including Range Selection

The low time duration of the master can be used to select the magnetic range of the sensor in SPC dynamic range selection mode.

Table 7-7 Master Pulse Timing for Dynamic Range Mode

Parameter	Symbol	Values			Unit	Note / Test Condition
		Min.	Typ.	Max.		
Master low time	$t_{m\text{low}}$	1.5	3.25	5	UT ¹⁾	Range = 200 mT (R=0)
		9	12	15	UT	Range = 100 mT (R=1)
		24	31.5	39	UT	Range = 50 mT (R=3)

1) UT = Programmed nominal SPC unit time.

Changing the range takes some time due to the settling time of internal circuitry. The first sample after a range switch therefore still displays a value sampled with the old range setting and the second transmission after changing the range displays the new range with reduced accuracy.

7.4.3 Synchronous Mode with ID Selection

In ID selection mode, one of up to four sensors are selectable on a bus (bus mode, 1 master with up to 4 slaves). This allows parallel connection of up to 4 sensors on one data line, as illustrated in [Figure 7-4](#).

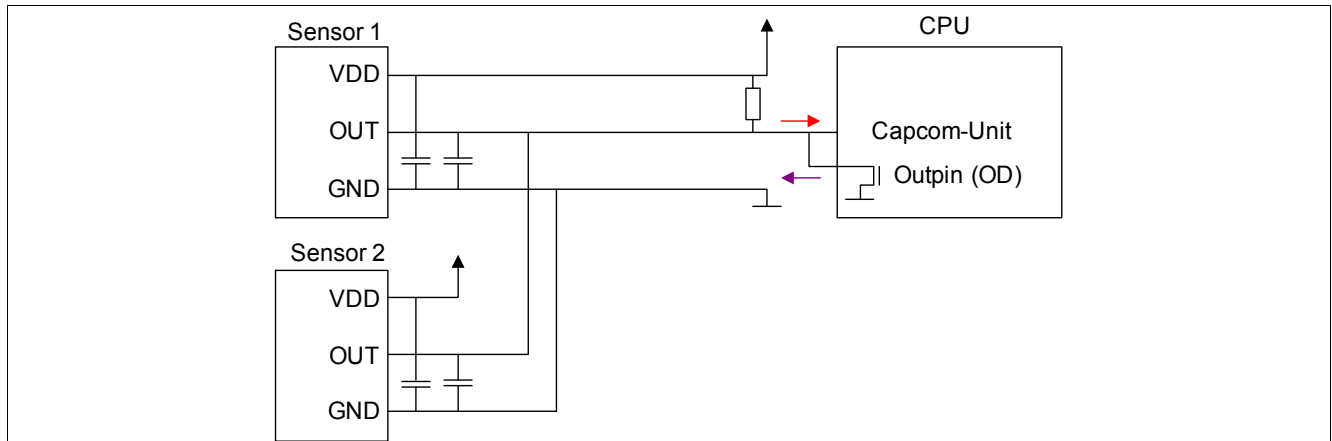

Figure 7-4 Bidirectional Communication with ID Selection

In this mode, the sensor starts to transfer complete packages only after receiving a master low pulse with an ID that is equivalent to the programmed value in its ID register. The mapping between master low time and ID is given in [Table 7-8](#). A proper addressing requires the different sensors on a same bus to be programmed with the same nominal SPC unit time.

Table 7-8 Master Pulse Timing for ID Selection Mode

Parameter	Symbol	Values			Unit	Note / Test Condition
		Min.	Typ.	Max.		
Master low time	$t_{m\text{low}}$	9	10.5	12	UT ¹⁾	ID = 0
		19	21	23	UT	ID = 1
		35.5	38	40.5	UT	ID = 2
		61.5	64.5	67.5	UT	ID = 3

1) UT = Programmed nominal SPC unit time.

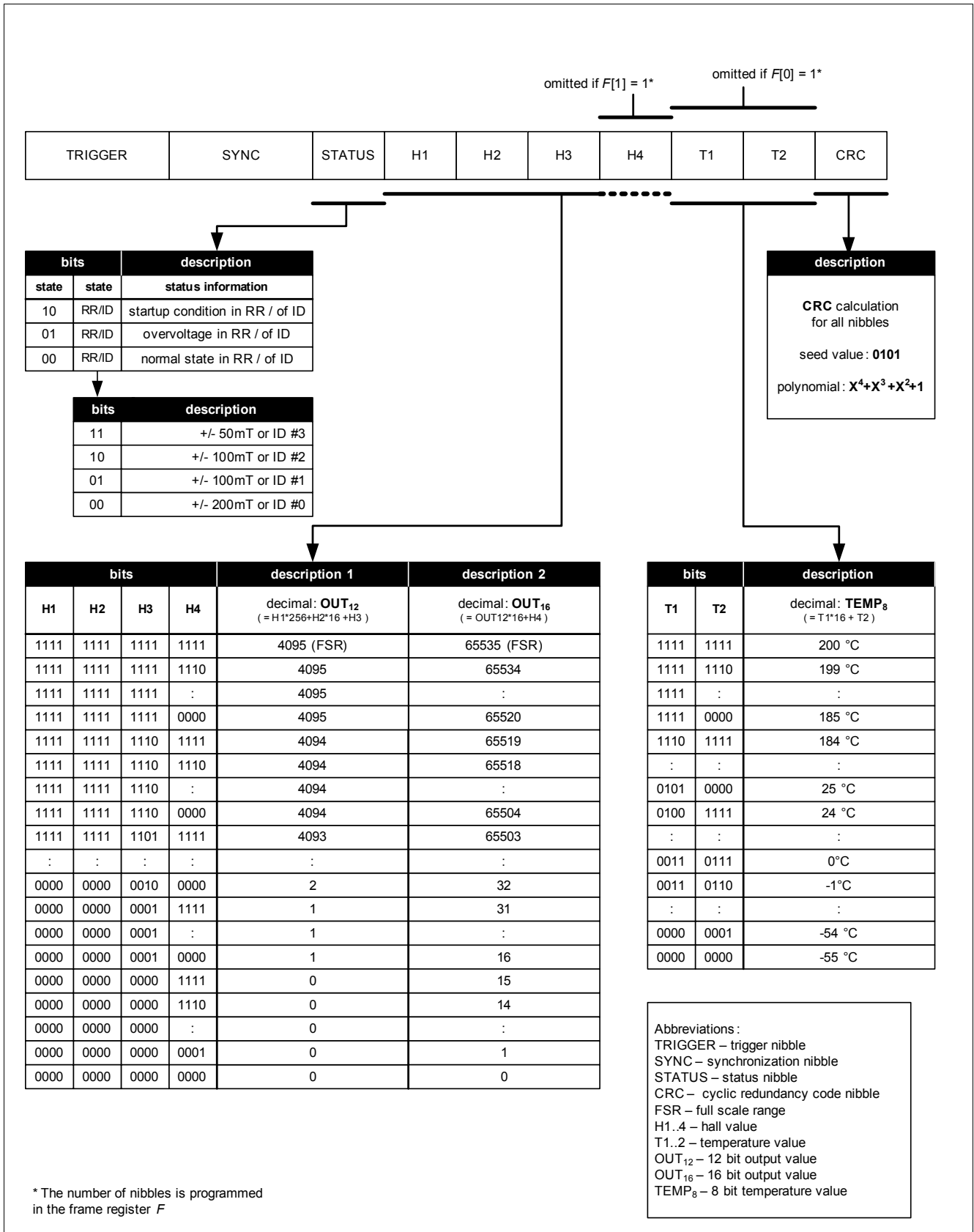

Figure 7-5 Content of a SPC Data Frame (5-8 Nibbles)

8 Configuration and Calibration Parameters

The TLE4998C8(D) has several configurable parameters which are stored in the EEPROM. These parameters affect the internal data processing and compensation and the output protocol. This chapter gives an overview of the parameters. A detailed description of all the parameters and the programming procedure is given in the [TLE4998 User's Manual](#).

Table 8-1 TLE4998C8(D) Parameters

Parameter	Setting range	Note
Magnetic range	±50 mT ±100 mT ±200 mT	Magnetic input range of Hall ADC
Gain	-4.0...4.0	Gain value of +1.0 corresponds to typical 32 LSB ₁₂ /mT sensitivity in 100 mT range (64 LSB ₁₂ /mT in 50mT range)
Offset	-16384 LSB ₁₂ ... 16384 LSB ₁₂	Quantization step: 1 LSB ₁₂
Clamping low level	0 LSB ₁₆ ... 64512 LSB ₁₆	Quantization step: 1024 LSB ₁₆ (see Figure 8-1)
Clamping high level	1023 LSB ₁₆ ... 65535 LSB ₁₆	Quantization step: 1024 LSB ₁₆
Bandwidth ¹⁾	80 Hz 240 Hz 440 Hz 640 Hz 860 Hz 1100 Hz 1390 Hz Off	Low-pass filter cut-off (-3 dB) frequency (see Figure 8-2)
1 st order temperature coefficient TC ₁	-1000 ppm/°C ... 2500 ppm/°C	²⁾
2 nd order temperature coefficient TC ₂	-4 ppm/°C ² ... 4 ppm/°C ²	³⁾
SPC unit time ¹⁾	2.0 μs ... 3.88 μs	see Chapter 7
SPC protocol frames	16 bit Hall + 8 bit temperature 16 bit Hall 12 bit Hall + 8 bit temperature 12 bit Hall	see Chapter 7
SPC mode	Synchronous Dynamic Range ID Selection	see Chapter 7

1) Subject to oscillator variation ±20%.

2) Relative range to Infineon temperature pre-calibration, the maximum adjustable range is limited by the register-size and depends on specific pre-calibrated TL setting, full adjustable range: -2441 to +5355 ppm/°C.

3) Relative range to Infineon temperature pre-calibration, the maximum adjustable range is limited by the register-size and depends on specific pre-calibrated TQ setting, full adjustable range: -15 to +15 ppm/°C².

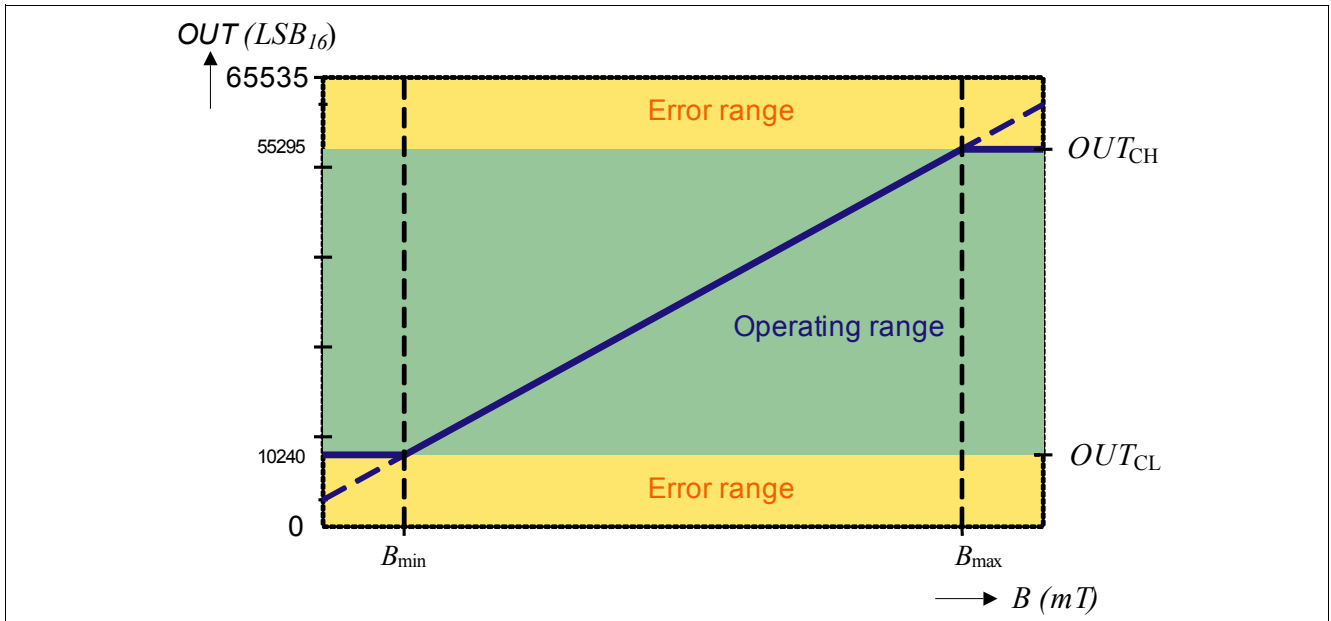

Figure 8-1 Clamping Example

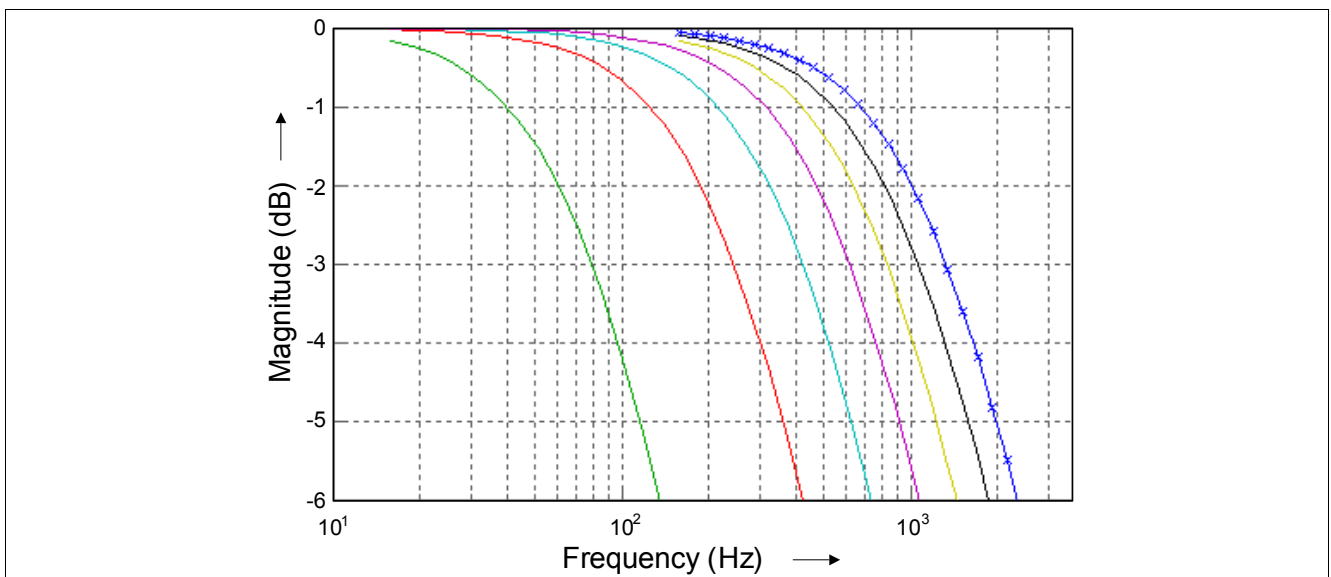

Figure 8-2 DSP Input Filter (Magnitude Plot)

9 Error Detection

Different error cases can be detected by the On-Board Diagnostics (OBD) and reported to the micro controller in the status nibble (see [Chapter 7](#)).

9.1 Voltages Outside the Operating Range

- Inside the ratings specified in [Table 3-1 “Absolute Maximum Ratings” on Page 8](#)
- Outside the range specified in [Table 4-1 “Operating Range” on Page 9](#)

The output signals an error condition if V_{DD} crosses the overvoltage threshold level.

Table 9-1 Overvoltage

Parameter	Symbol	Values			Unit	Note / Test Condition
		Min.	Typ.	Max.		
Overvoltage threshold	V_{DDov}	16.65	17.5	18.35	V	

9.2 EEPROM Error Correction

The parity method is able to correct a single bit in the EEPROM line. One other single bit error in another EEPROM line can also be detected, but not corrected. In case there is an incorrectable EEPROM failure, the open drain stage is disabled and permanently kept in off state (high ohmic/sensor defect).

10 PG-TDSO-8 Package Outlines

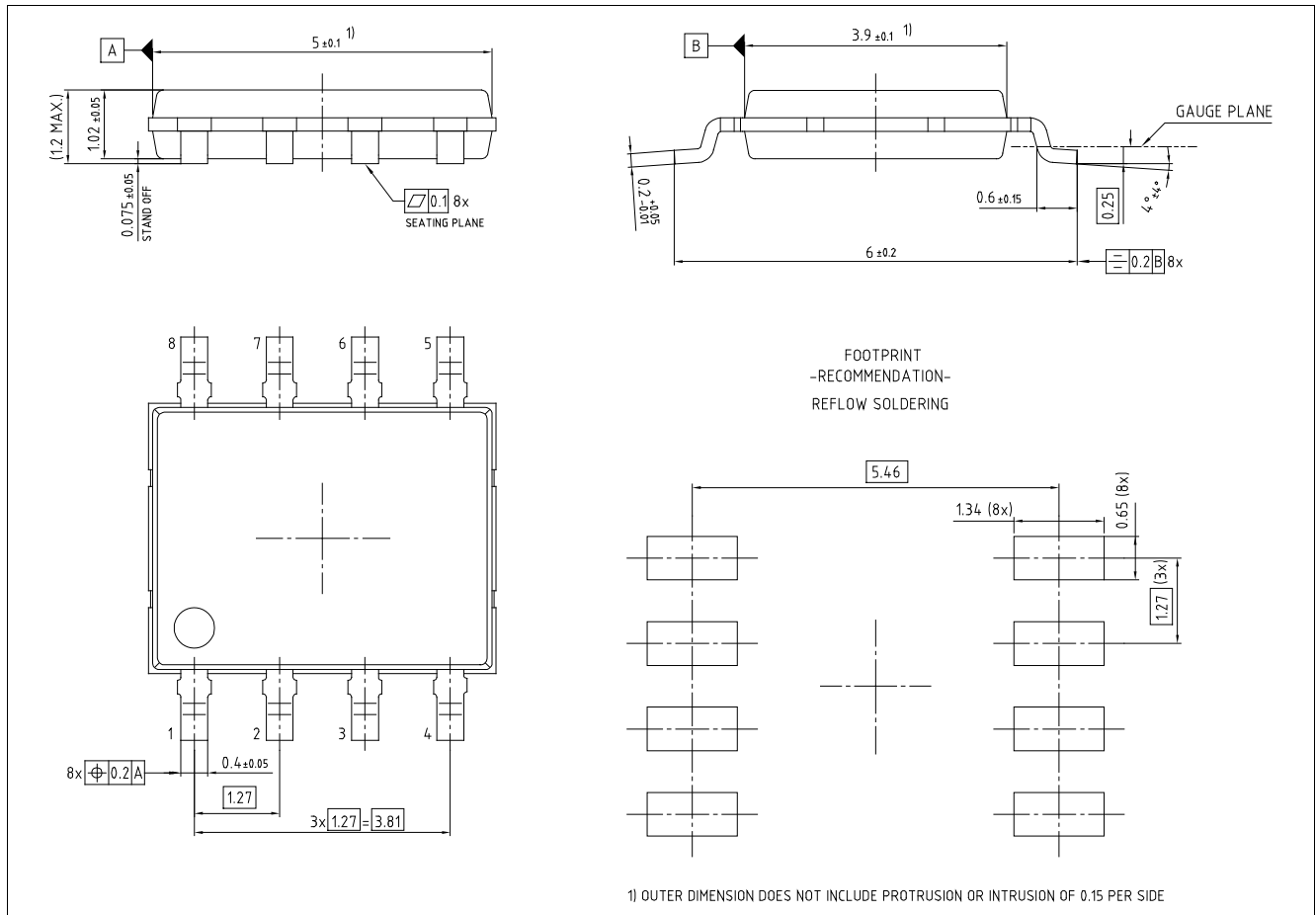

Figure 10-1 PG-TDSO-8 (PG-TDSO-Plastic Green Thin Dual Small Outline), Package Dimensions

10.1 Distance Chip to package

Figure 10-2 shows the distance of the chip surface to the PG-TDSO-8 surface.

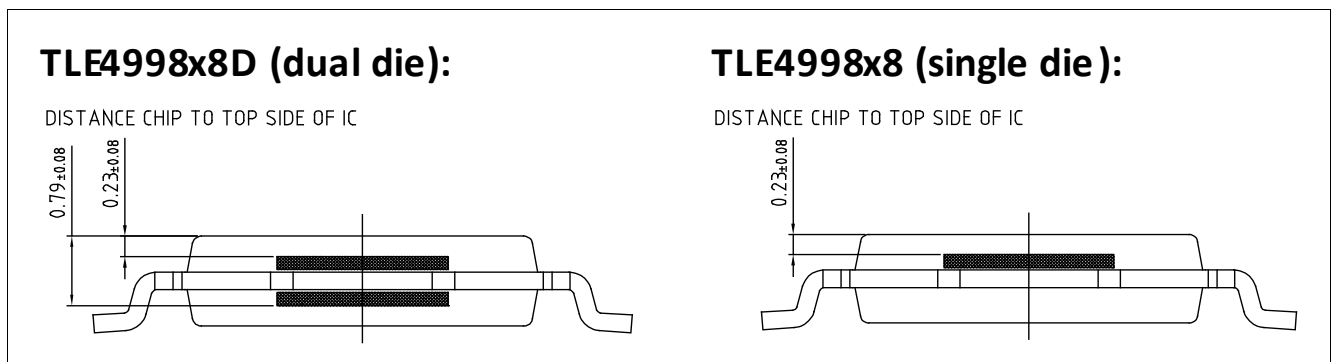

Figure 10-2 Distance of chip surface to package surface

10.2 Moisture Sensitivity Level (MSL)

The PG-TDSO-8 fulfills the MSL level 3 according to IPC/JEDEC J-STD-033B.1.

10.3 PG-TDSO-8 Package Marking

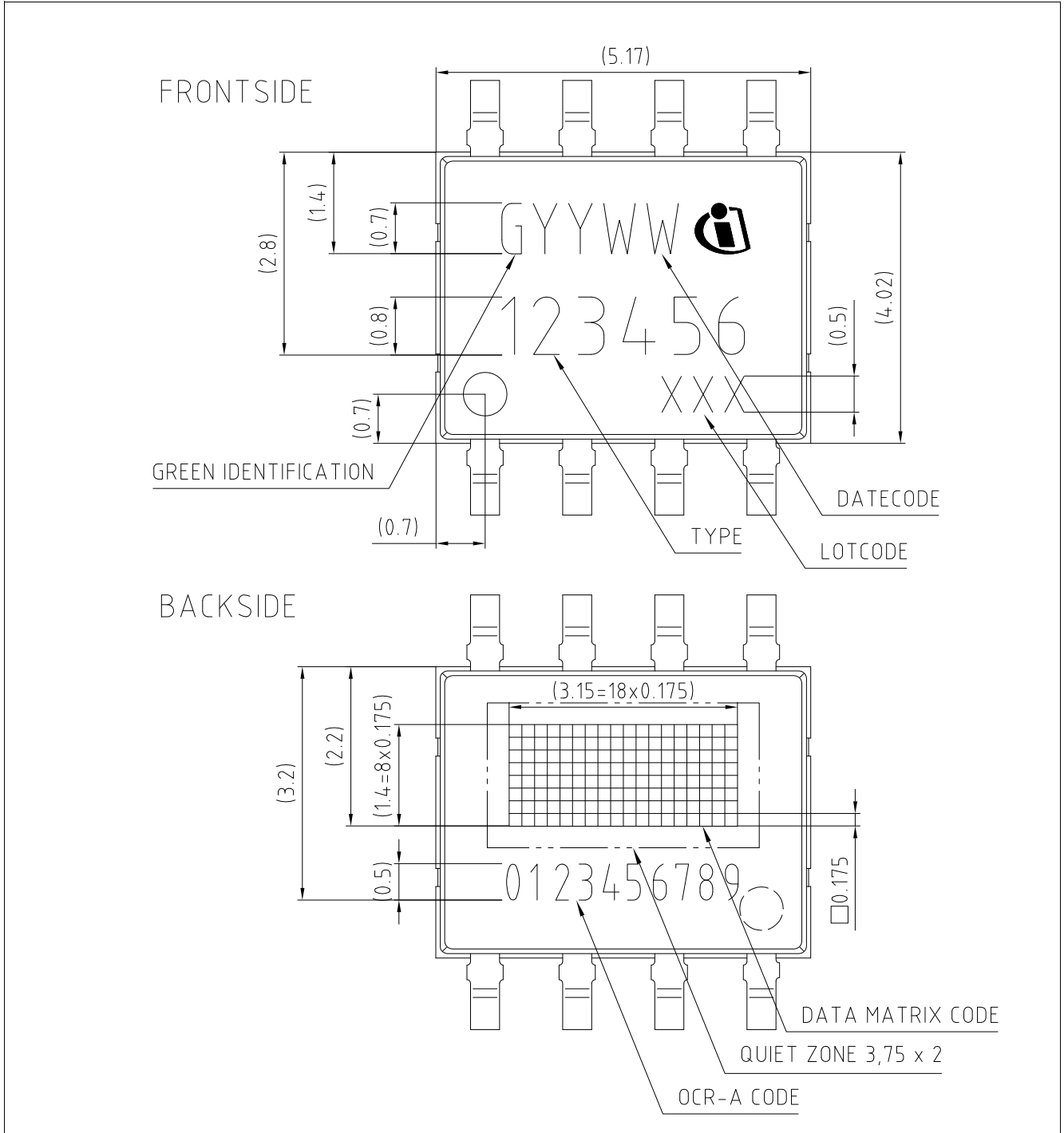

Figure 10-3 PG-TDSO-8 (PG-TDSO-Plastic Green Thin Dual Small Outline), Package Marking

Revision History

Page or Item	Subjects (major changes since previous revision)
Revision 1.1, 2017-01	
Page 10	Added Note / Test Condition to parameter Output noise (rms)
Page 12	Added Note / Test Condition to parameter Output noise (rms)
Page 15	Corrected typo in Chapter 7.1 , 9 μ s low pulse corrected to 3 unit time (UT)

Trademarks of Infineon Technologies AG

AURIX™, C166™, CanPAK™, CIPOS™, CIPURSE™, EconoPACK™, CoolMOS™, CoolSET™, CORECONTROL™, CROSSAVE™, DAVE™, EasyPIM™, EconoBRIDGE™, EconoDUAL™, EconoPIM™, EiceDRIVER™, eupec™, FCOS™, HITFET™, HybridPACK™, I²RF™, ISOFACE™, IsoPACK™, MIPAQ™, ModSTACK™, my-d™, NovalithIC™, OptiMOS™, ORIGA™, PRIMARION™, PrimePACK™, PrimeSTACK™, PRO-SIL™, PROFET™, RASIC™, ReverSave™, SatRIC™, SIEGET™, SINDRION™, SIPMOS™, SmartLEWIS™, SOLID FLASH™, TEMPFET™, thinQ!™, TRENCHSTOP™, TriCore™.

Other Trademarks

Advance Design System™ (ADS) of Agilent Technologies, AMBA™, ARM™, MULTI-ICE™, KEIL™, PRIMECELL™, REALVIEW™, THUMB™, μ Vision™ of ARM Limited, UK. AUTOSAR™ is licensed by AUTOSAR development partnership. Bluetooth™ of Bluetooth SIG Inc. CAT-iq™ of DECT Forum. COLOSSUS™, FirstGPS™ of Trimble Navigation Ltd. EMV™ of EMVCo, LLC (Visa Holdings Inc.). EPCOS™ of Epcos AG. FLEXGO™ of Microsoft Corporation. FlexRay™ is licensed by FlexRay Consortium. HYPERTERMINAL™ of Hilgraeve Incorporated. IEC™ of Commission Electrotechnique Internationale. IrDA™ of Infrared Data Association Corporation. ISO™ of INTERNATIONAL ORGANIZATION FOR STANDARDIZATION. MATLAB™ of MathWorks, Inc. MAXIM™ of Maxim Integrated Products, Inc. MICROTEC™, NUCLEUS™ of Mentor Graphics Corporation. Mifare™ of NXP. MIPI™ of MIPI Alliance, Inc. MIPS™ of MIPS Technologies, Inc., USA. muRata™ of MURATA MANUFACTURING CO., MICROWAVE OFFICE™ (MWO) of Applied Wave Research Inc., OmniVision™ of OmniVision Technologies, Inc. Openwave™ Openwave Systems Inc. RED HAT™ Red Hat, Inc. RFMD™ RF Micro Devices, Inc. SIRIUS™ of Sirius Satellite Radio Inc. SOLARIS™ of Sun Microsystems, Inc. SPANSION™ of Spansion LLC Ltd. Symbian™ of Symbian Software Limited. TAIYO YUDEN™ of Taiyo Yuden Co. TEAKLITE™ of CEVA, Inc. TEKTRONIX™ of Tektronix Inc. TOKO™ of TOKO KABUSHIKI KAISHA TA. UNIX™ of X/Open Company Limited. VERILOG™, PALLADIUM™ of Cadence Design Systems, Inc. VLYNQ™ of Texas Instruments Incorporated. VXWORKS™, WIND RIVER™ of WIND RIVER SYSTEMS, INC. ZETEX™ of Diodes Zetex Limited.

Last Trademarks Update 2011-02-24

www.infineon.com

Published by Infineon Technologies AG