

TLE4990

TLE4990-E6782

Programmable Linear Output Hall Sensor

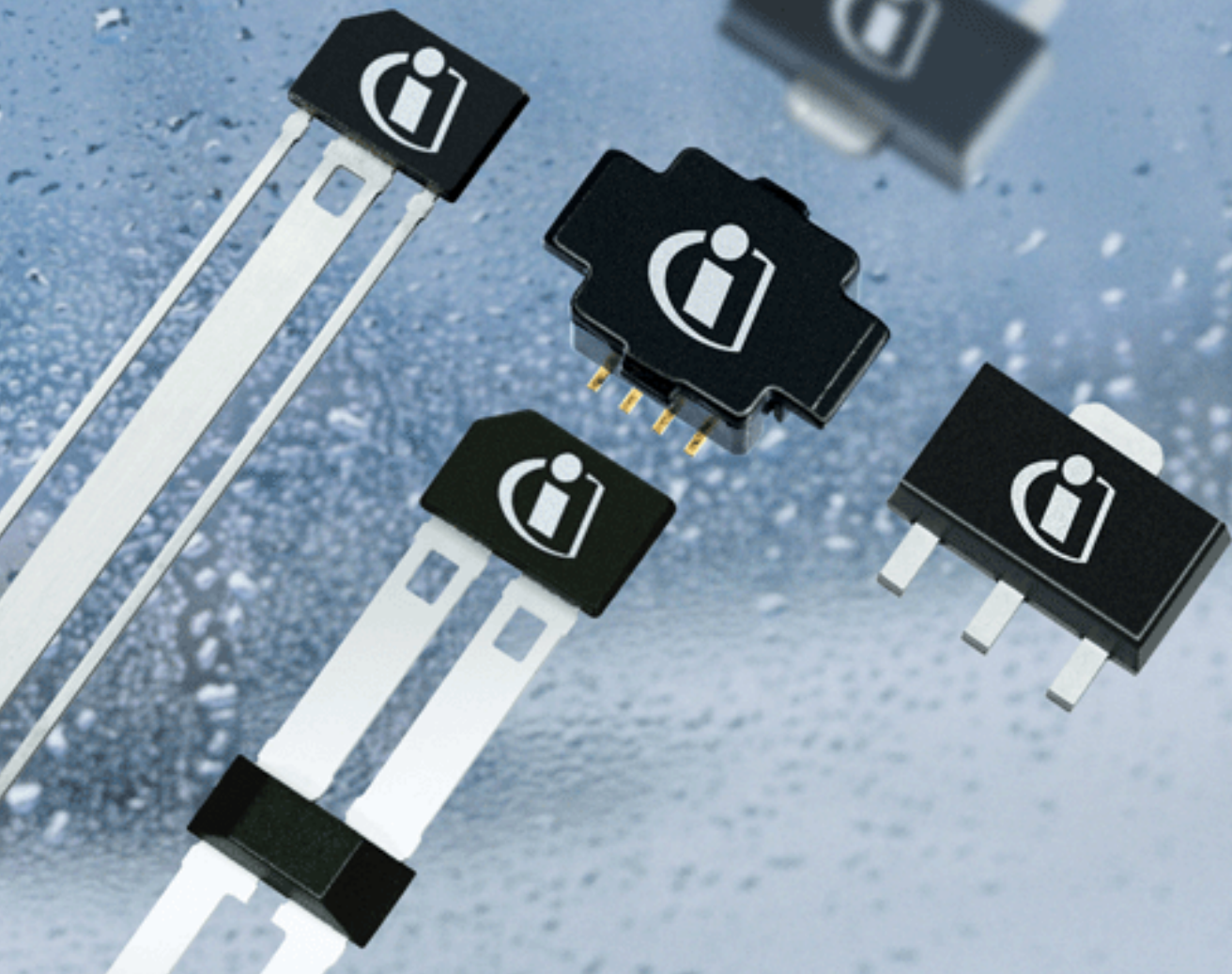

Sensors



Never stop thinking

Edition 2005-11

**Published by Infineon Technologies AG,
St.-Martin-Strasse 53,
81669 München, Germany**

**© Infineon Technologies AG 2005.
All Rights Reserved.**

Attention please!

The information given in this document shall in no event be regarded as a guarantee of conditions or characteristics ("Beschaffenhheitsgarantie"). With respect to any examples or hints given herein, any typical values stated herein and/or any information regarding the application of the device, Infineon Technologies hereby disclaims any and all warranties and liabilities of any kind, including without limitation warranties of non-infringement of intellectual property rights of any third party.

Information

For further information on technology, delivery terms and conditions and prices please contact your nearest Infineon Technologies Office (www.infineon.com).

Warnings

Due to technical requirements components may contain dangerous substances. For information on the types in question please contact your nearest Infineon Technologies Office.

Infineon Technologies Components may only be used in life-support devices or systems with the express written approval of Infineon Technologies, if a failure of such components can reasonably be expected to cause the failure of that life-support device or system, or to affect the safety or effectiveness of that device or system. Life support devices or systems are intended to be implanted in the human body, or to support and/or maintain and sustain and/or protect human life. If they fail, it is reasonable to assume that the health of the user or other persons may be endangered.

TLE4990

Revision History: 2004-11 V 2.2

Previous Version: V 2.0 2004-05

Page	Subjects (major changes since last revision)
6	Correction of typing error: Horizontal position of Hall cell (2.67mm)
21	Correction of typing errors: Width of package (5.34mm) and width of tape (0.39mm) Version 2.1: wrong tolerance of tape width

TLE4990

Revision History: 2005-01 V 2.3

Previous Version: V 2.2 2004-11

Page	Subjects (major changes since last revision)
10	Table 2 Correction of typing error $V_{OUTOV} \min = -0.3V$ instead of 0.3V

TLE4990

Revision History: 2005-11 V 2.4

Previous Version: 2.3

Page	Subjects (major changes since last revision)
	Removal of Version TLE4990-E6785

We Listen to Your Comments

Any information within this document that you feel is wrong, unclear or missing at all? Your feedback will help us to continuously improve the quality of this document. Please send your proposal (including a reference to this document) to:

feedback.sensors@infineon.com

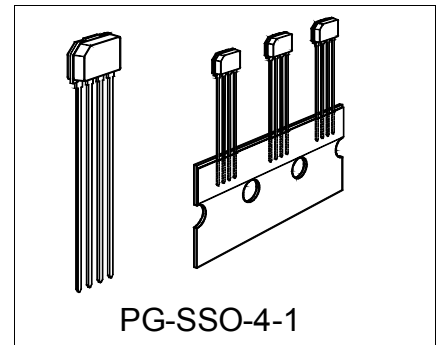

Table of Contents	Page
1 Overview	5
1.1 Features	5
1.2 Target Applications	5
2 Functional Description	6
Pin Configuration	6
General	7
Zero-field Output Voltage (Vzero)	7
Magnetic Sensitivity (S)	7
Temperature Gain Compensation	7
Clamping Option	7
Block Diagram	8
Transfer Functions	9
3 Absolute Maximum Ratings	10
4 Operating Range	11
5 Electrical and Magnetic Parameters	12
Electrical Parameters	12
Magnetic Parameters	13
6 Signal Processing	14
6.1 Magnetic Field Ranges	14
Range register	14
6.2 Gain Setting	15
Gain Register	15
6.3 Offset Setting	16
Offset Register	16
6.4 Clamping	17
7 Error Detection	18
8 Calibration and Fusing	19
Data Transfer Protocol	19
Programming of Sensors with Common Supply Lines	19
Sensor Interface Tool	19
9 Application Circuit	20
10 Package Outlines	21

1 Overview

1.1 Features

- Single supply voltage 4.5 - 5.5 V
- Temperature Range from -40 °C up to 150 °C
- Very slim 4-pin package with only 1mm thickness
- Temperature compensation
- Programmable parameters stored in fuse memory:
 - magnetic range and magnetic sensitivity (gain)
 - zero field voltage (offset)
 - clamping option
 - memory lock
 - temperature coefficient (calibrated and fused during production)
- Low drift of output signal over temperature and lifetime
- Continuous measurement ranges between -200 mT and +200 mT or 0 and 400 mT
- Output short circuit protection
- Very linear and ratiometric rail-to-rail output signal with push-pull output
- Reverse polarity and overvoltage protection for all pins
- On-board diagnostics (wire breakage detection)
- Individual programming and operation of multiple sensors with common power supply
- Completely calibrated and fused version -E6782



1.2 Target Applications

- Robust replacement of potentiometers
 - No mechanical abrasion
 - Resistant to humidity, temperature, pollution, and vibration
- Linear and angular position sensing in automotive applications like pedal position, suspension control, valve or throttle position, headlight levelling, and steering angle
- High current sensing for battery management, motor control, and electronic fuse

Type	Package
TLE4990	PG-SSO-4-1
TLE4990-E6782	PG-SSO-4-1

2 Functional Description

Pin Configuration

Figure 1 shows the location of the hall element in the chip.

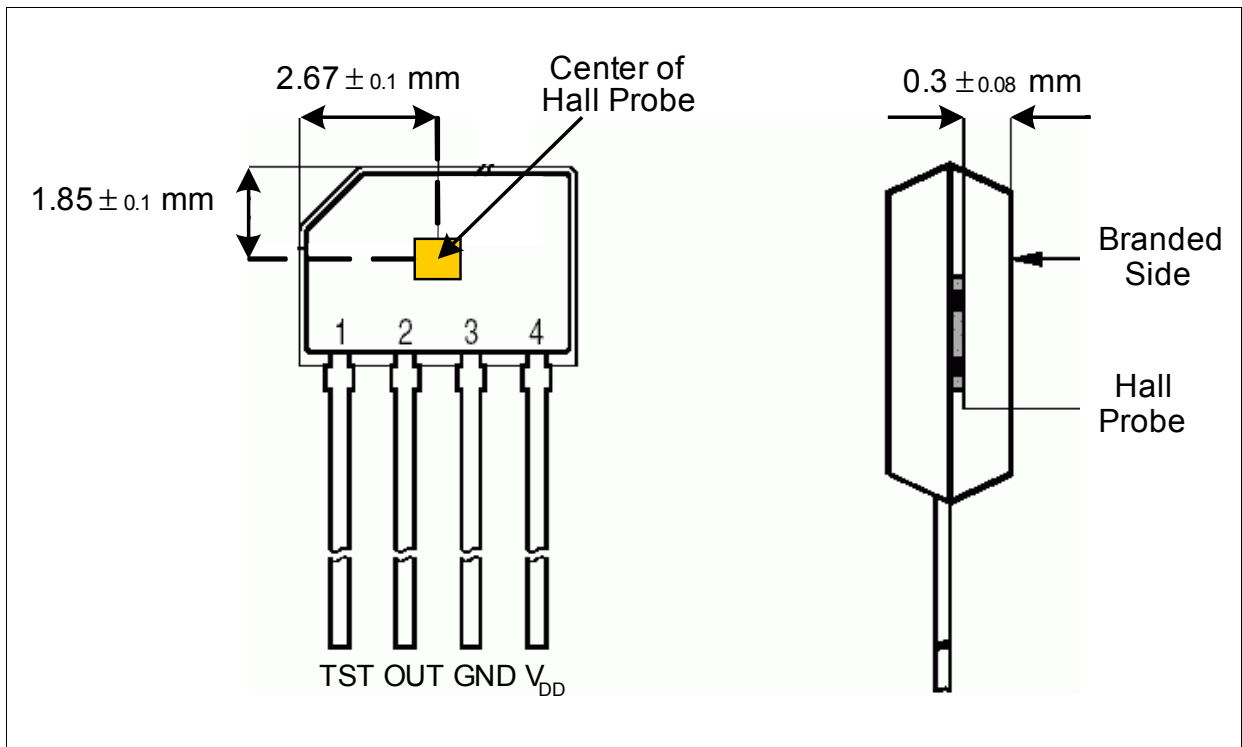

Figure 1 Pin Configuration and Hall Cell Location

Table 1 Pin Definitions and Functions

Pin No.	Symbol	Function
1	<i>TST</i>	Test pin, must be grounded
2	<i>OUT</i>	Output voltage / programming interface
3	<i>GND</i>	Ground
4	<i>V_{DD}</i>	Supply voltage / programming interface

General

The linear Hall IC TLE4990 has been designed specifically to meet the demands of highly accurate rotation and position detection, as well as for current measurement applications.

The sensor provides a ratiometric analog output voltage which is ideally suited for A/D conversion with the supply voltage as a reference.

The IC is produced in BiCMOS technology with high voltage capability and also providing reverse polarity protection.

Zero-field Output Voltage (V_{zero})

The output voltage with no magnetic field present is called the zero field voltage V_{zero} . It is programmable within the range of 3% to 19% of V_{DD} (for Bipolar bit = 0) and 40% to 60% of V_{DD} (for Bipolar bit = 1) by 10 ODAC bits with a resolution of 1.0 mV to 1.2 mV.

Magnetic Sensitivity (S)

The magnetic sensitivity is set in two steps: First the “coarse gain” is selected out of 8 values (3 PRE bits). Then the “fine gain” is adjusted by another 10 GDAC bits.

The resulting range of sensitivity extends from 15 mV/mT to 180 mV/mT at the nominal supply voltage of 5 V. Note that as the sensitivity is ratiometric, it will also depend linearly on the supply voltage.

The sensitivity of the -E6782 version is programmed during production.

It is calibrated to a value of 20 mV/mT at the nominal supply voltage of 5 V.

Temperature Gain Compensation

The temperature compensation of the sensitivity is programmed during production.

The value of +350 ppm/°C provides an excellent accuracy for the use of a SmCo permanent magnet. Stability is achieved by the dynamic offset cancellation technique to eliminate any spurious mechanical or temperature effects.

Clamping Option

It is possible to reduce the output voltage swing from its original 3%... 97% V_{DD} to a limited swing of 10% ... 90% V_{DD} by setting the clamping bit. This allows to detect a broken wire. In this case the output voltage is tied to $\leq 6\%$ or $\geq 94\%$ of V_{DD} .

Note: The -E6782 version has this feature disabled.

Block Diagram

Figure 2 shows a simplified block diagram.

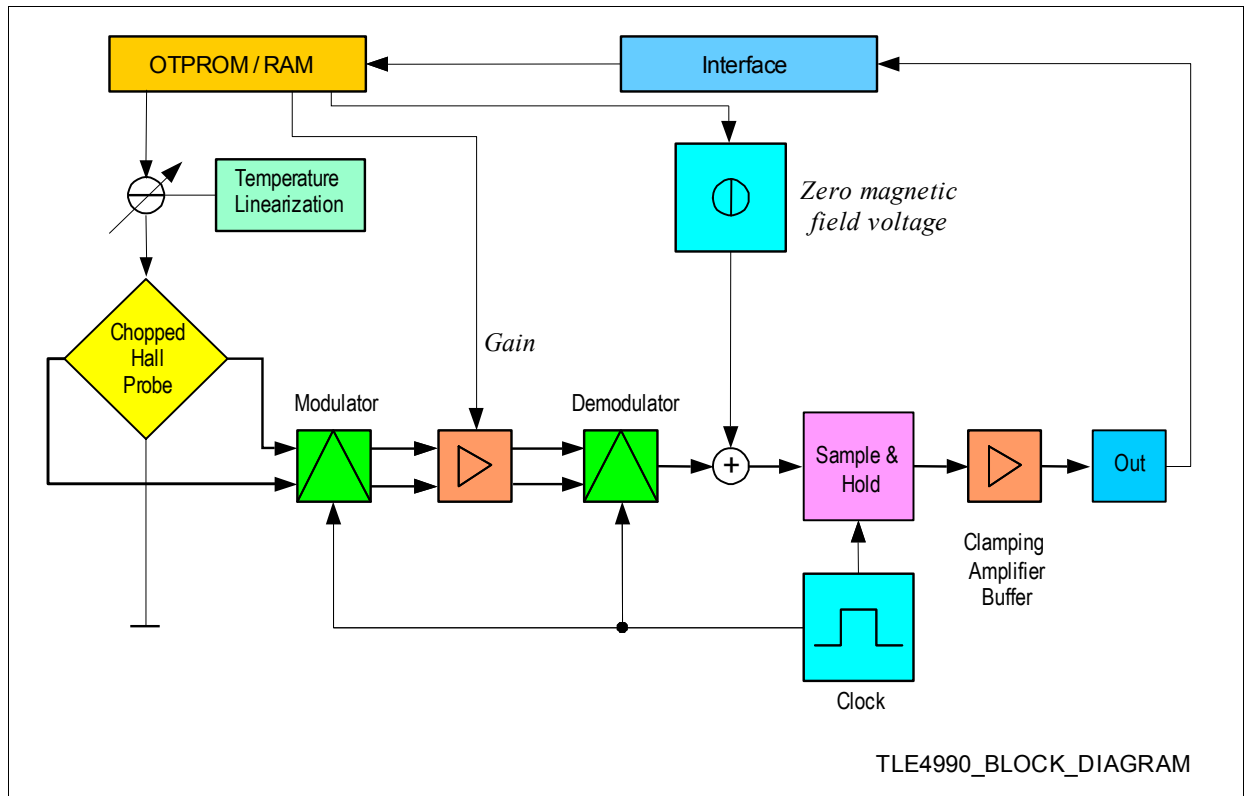

Figure 2 Block Diagram

Principle of Operation

- A magnetic flux is measured by a Hall-Effect cell.
- The Temperature compensation modulates the bias current of the hall cell.
- The output signal from the Hall-Effect cell is amplified.
- A zero field voltage is added.
- The output voltage range can be clamped by limiters.
- The final output value is amplified and buffered.
- The output voltage is proportional to the supply voltage (ratiometric behavior).
- An OBD (**O**n **B**oard **D**iagnostics) circuit connects the output to V_{DD} or GND in case of errors.

Transfer Functions

The examples in **Figure 3** show how different magnetic field ranges can be mapped to the output voltage.

- Polarity mode:
 - **Unipolar**: only magnetic fields in one direction are measured. The zero field voltage is near to the GND level.
 - **Bipolar**: Magnetic fields can be measured in both orientations. The zero field voltage is about the half voltage.

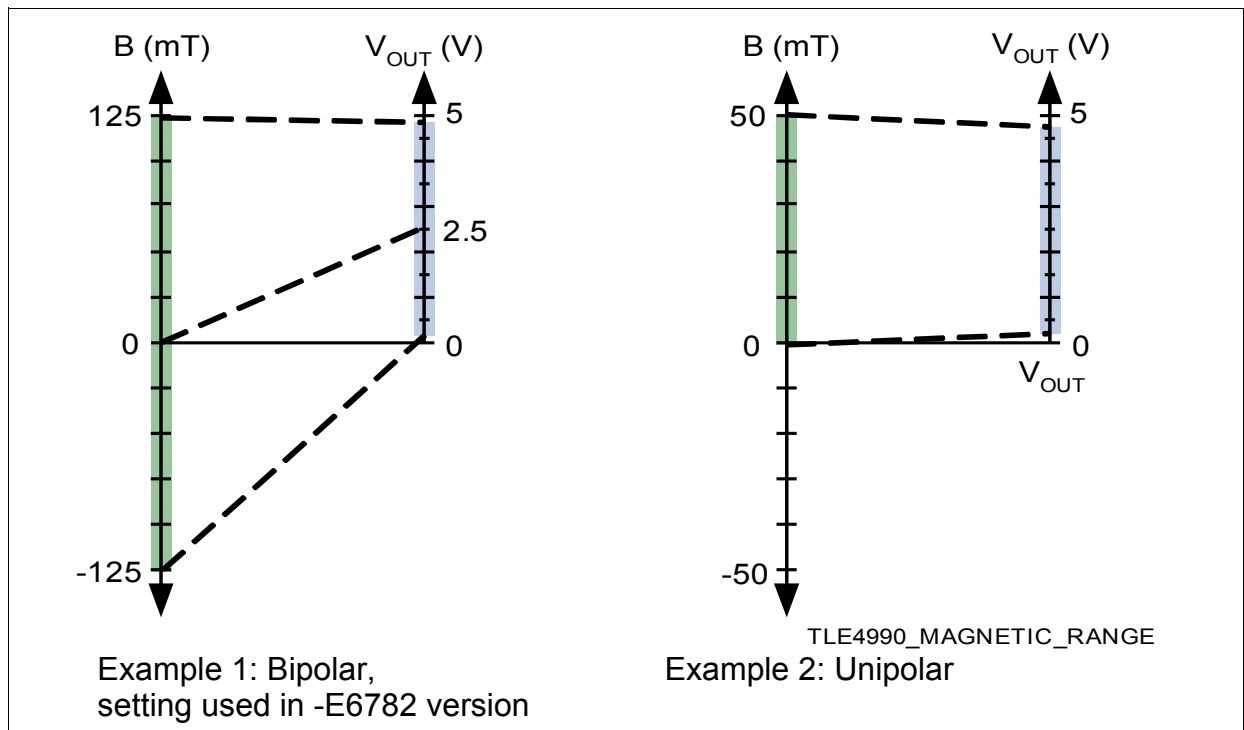

Figure 3 Examples of Operation

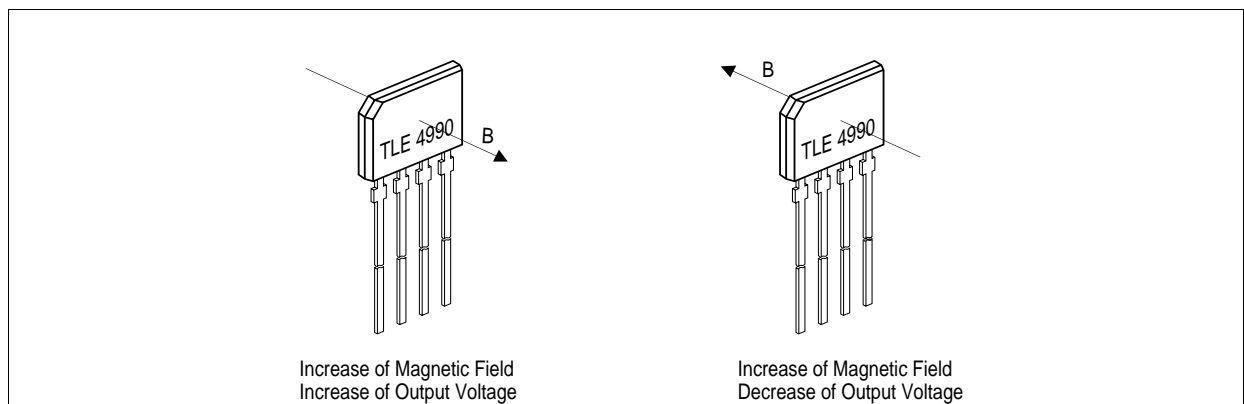

Figure 4 Magnetic Field Direction Definition

3 Absolute Maximum Ratings

Table 2 Absolute Maximum Rating Parameters ¹⁾

Parameter	Symbol	Limit Values		Unit	Notes
		min.	max.		
Storage temperature	T_{ST}	-40	150	°C	
Junction temperature	T_J	-40	160	°C	
Voltage on V_{DD} pins with respect to ground (V_{SS})	V_{DD}	-18	24	V	for $T_A \leq 80$ °C max. 10 min.
Voltage on output pin with respect to ground (V_{SS})	V_{OUTov}	-0.3	16		for $T_A \leq 80$ °C max. 5 min.
Magnetic field	B_{MAX}	-	unlimited	T	
ESD protection	V_{ESD}	-	2.0	kV	according HBM JESD22-A114-B

¹⁾ Only valid if the MEMlock bit is set and the TST pin is connected to GND.

Note: Stresses above those listed under “Absolute Maximum Ratings” may cause permanent damage to the device. This is a stress rating only and functional operation of the device at these or any other conditions above those indicated in the operational sections of this specification is not implied. Exposure to absolute maximum rating conditions for extended periods may affect device reliability. During absolute maximum rating overload conditions ($V_{IN} > V_{DD}$ or $V_{IN} < V_{SS}$) the voltage on V_{DD} pins with respect to ground (V_{SS}) must not exceed the values defined by the absolute maximum ratings.

4 Operating Range

The following operating conditions must not be exceeded in order to ensure correct operation of the TLE4990. All parameters specified in the following sections refer to these operating conditions, unless otherwise noticed.

Table 3 Operating Condition Parameters¹⁾

Parameter	Symbol	Limit Values		Unit	Notes
		min.	max.		
Supply voltage	V_{DD}	4.5	5.5	V	
Load resistance	R_L	4.7 7	-	k Ω	for OBD parameters ²⁾
Load capacitance	C_L	0	50	nF	³⁾
Ambient temperature ⁴⁾	T_A	-40	150	°C	

¹⁾ Keeping signal levels within the limits specified in this table, ensures operation without overload conditions.

²⁾ OBD= **O**n **B**oard **D**iagnostics (see [Table 12](#)).

³⁾ A minimum capacitance of 1 nF is recommended in order to improve the EMC behavior.

⁴⁾ $R_{THja} \leq 150$ K/W

5 Electrical and Magnetic Parameters

Electrical Parameters

Table 4 Electrical characteristics

Parameter	Symbol	Limit Values			Unit	Notes
		min.	typ.	max.		
Output voltage range	V_{OUT}	3	-	97	% of V_{DD}	$R_{LOAD} \geq 4.7 \text{ k}\Omega$
Supply current	I_{DD}	3.5	-	5.5	mA	$I_{OUT} = 0 \text{ mA}$ ¹⁾
Output current	I_{OUT}	-1.2	-	1.2	mA	
Output Resistance	R_{OUT}	-	3	11.2	Ω	¹⁾
Zero field voltage	V_{ZERO}	3	-	18	% V_{DD}	Bipolar-Bit = 0 ^{2) 3)} Bipolar-Bit = 1 ^{2) 3)}
		42	-	59		
		49.95	50	50.05		only version -E6782 ³⁾
Zero field voltage drift	ΔV_{ZERO}	-10	-	10	mV	over lifetime
		-30	-	0		$-40^\circ\text{C} \leq T < 25^\circ\text{C}$
		-30	-	0		$25^\circ\text{C} \leq T \leq 150^\circ\text{C}$
		-40	-	0		$-40^\circ\text{C} \leq T \leq 150^\circ\text{C}$ ⁴⁾
Ratiometry	Rat	99.8	100	100.2	%	⁵⁾
Power on time	t_{Pon}	0.3	0.6	0.75	ms	⁶⁾
Max. phase shift error	ϕ_{ERR}	2	4	8	degree	@ 100 Hz sine input
Output noise	V_{noise}	-	1.2	-	mV _{RMS}	⁷⁾
Maximum operating frequency	f_{op}	1.1	1.6	2.3	kHz	-3 dB corner frequency

¹⁾ Valid for V_{OUT} in the range from 10% to 90% V_{DD} .

²⁾ Not for the -E6782 version.

³⁾ @ 25 °C

⁴⁾ For Sensitivity $S < 80 \text{ mV/mT}$, for higher sensitivities the zero field drift is dominant (see [Table 5](#)).

⁵⁾ Definition: $Rat = (V_{OUT}(V_{DD}) / V_{DD}) / (V_{OUT}(V_{DD} = 5 \text{ V}) / 5 \text{ V}) \times 100\%$
for V_{out} in the range from 10% V_{DD} to 90% V_{DD} .

⁶⁾ The output voltage has reached 99% of its final value within t_{Pon} after power on.

⁷⁾ No external filtering, with a sensitivity of 30 mV/mT (digital switching noise included) @ 25 °C.

Magnetic Parameters

Table 5 Magnetic Characteristics

Parameter	Symbol	Limit Values			Unit	Notes
		min.	typ	max.		
Sensitivity	S	15	-	180	mV/mT	programmable for TLE4990 ^{1) 2)}
		19.8	20	20.2	mV/mT	TLE4990-E6782 ^{1) 3)}
Magnetic field range	MFR	± 13.05	-	± 204.5	mT	Bipolar-Bit = 1 ⁴⁾
		26.1	-	409		Bipolar-Bit = 0 ⁴⁾
		± 115.8	± 117.5	± 118.2		TLE4990-E6782
Linearity	Lin	99.9	100	100.1	%	⁵⁾
Temperature coefficient of sensitivity	α	200	350	500	ppm/ °C	⁶⁾
Sensitivity drift over lifetime	ΔS_L	-0.9	-	0.9	%	$T_a = 25\text{ °C}$
Zero field drift over temperature	ΔB_0	-500	-	150	μT	valid for $S > 80\text{ mV/mT}$ ⁷⁾
Resolution	B_n	20	-	60	μT_{RMS}	⁸⁾

1) @ $V_{DD} = 5\text{ V}$

2) In the lowest programmable sensitivity range a sensitivity less or equal to min(S) is guaranteed.
In the highest programmable sensitivity range a sensitivity of greater or equal to max(S) is guaranteed.
The ratio of max(S) / min(S) ≥ 15 .

3) @ 25 °C

4) Not for the -E6782 version.

5) $B_{10\%}$ is the magnetic field, at which $V_{OUT} = 0.1 \times V_{DD}$.
 $B_{90\%}$ is the magnetic field, at which $V_{OUT} = 0.9 \times V_{DD}$.
 $V_{OUT,id} = [0.1 + 0.8 \times (B - B_{10\%}) / (B_{90\%} - B_{10\%})] \times V_{DD}$.
 $Lin = (V_{OUT} / V_{OUT,id} - 1) \cdot 100\%$ for all V_{OUT} between 10% V_{DD} and 90% V_{DD} .

6) The temperature coefficient of the magnetic sensitivity is the slope of a linear least-square fit through the real curve.

7) For lower sensitivities, the zero voltage drift is dominant (see [Table 4](#)).

8) Equivalent to magnetic input noise at 25 °C . The equivalent magnetic input noise depends on the selected sensitivity. At highest sensitivity it is typically $25\ \mu\text{T}_{RMS}$, at lowest sensitivity it is typically $50\ \mu\text{T}_{RMS}$ at 25 °C .

6 Signal Processing

6.1 Magnetic Field Ranges

Note: The Range setting is fixed in the -E6782 version.

The output signal of the Hall cell is amplified in the pre-amplifier.

Eight ranges can be selected by setting the PRE bits.

The output voltage range of 3 ... 97% of V_{DD} leads to a swing of 4.7 V at $V_{DD} = 5$ V.

Therefore the product of sensitivity and full scale range is always 4.7 V.

Note: Sensitivity x Full Scale range = 4.7 V

Table 6 Range Setting

Range	PRE bits			Sensitivity (mV/mT) Typical Values		Magnetic Full Scale Range (mT)	
	PRE2	PRE1	PRE0	min.	max.	min.	max.
0	0	0	0	11.49	16.49	285	409
1	0	0	1	16.17	23.20	203	291
2	0	1	0	22.75	32.65	144	207
3	0	1	1	32.00	45.96	102	147
4	1	0	0	45.04	64.63	72.7	104
5	1	0	1	63.38	90.92	51.7	74.2
6	1	1	0	89.16	127.9	36.8	52.7
7	1	1	1	125.5	180.0	26.1	37.5

In the bipolar mode, the full scale range is composed of a positive and a negative part with the half value each. (e.g. ± 142.4 mT ... ± 204.4 mT in range 0).

Note: The range should be set before the calibration of the gain.

Range register

PRE (Preamplifier)

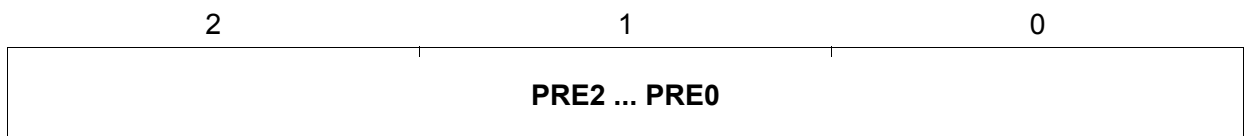

6.2 Gain Setting

Note: The Gain setting is fixed in the -E6782 version.

The sensitivity is defined by the range (Preamp) and the gain setting. The output of the preamplifier is multiplied with the gain value.

The sensitivity can be set in 1024 steps.

Table 7 Gain

Parameter	Symbol	Limit Values		Unit	Notes
		min.	max.		
Register size	-	10		bit	
Gain range	-	1	1.43	-	

Gain Register

Gain

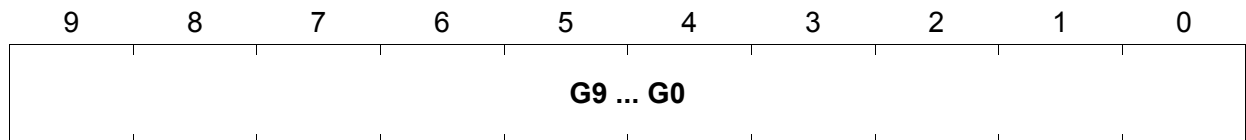

Table 8 Gain Register Setting

Gain	G		Remark
	Dec.	Bin. (G9 ... G0)	
1	0	000000000	minimum gain
1.43	1023	111111111	maximum gain

6.3 Offset Setting

Note: The Offset value is fixed in the -E6782 version

The offset voltage corresponds to an output voltage with zero field at the sensor. It can be set in 1024 steps in two different voltage ranges.

Table 9 Offset

Parameter	Symbol	Limit Values		Unit	Notes
		min.	max.		
Register size	-	10		bit	
Offset range	-	3 40	19 60	% of V_{DD}	Bipolar-Bit = 0 ^{1) 2)} Bipolar-Bit = 1
Offset quantization steps	ΔV_{OS}	0.97 1.22		mV	Bipolar-Bit = 0 ²⁾ Bipolar-Bit = 1

¹⁾ The -E6782 version is programmed to 50% V_{DD} .

²⁾ $V_{DD} = 5\text{ V}$

Offset Register

Offset

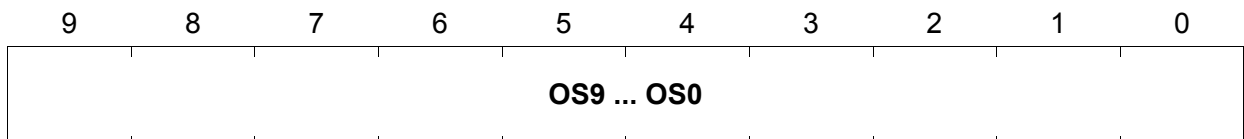

Table 10 Offset Register Setting

Offset	OS		BIP	Remark
	Dec.	Bin. (OS9 ... OS0)		
3% of V_{DD}	0	0000000000	0	Unipolar
40% of V_{DD}	0	0000000000	1	Bipolar
19% of V_{DD}	1023	1111111111	0	Unipolar
60% of V_{DD}	1023	1111111111	1	Bipolar

6.4 Clamping

Note: The Clamping function is not enabled in the -E6782 version

The clamping function is useful to split the output voltage range into operating range and error ranges.

If the magnetic field is outside the selected measurement range, the output voltage V_{out} is limited to the clamping values.

Therefore an output voltage in the error range indicates a wire breakage (see [Open Circuit \(OBD parameters\)](#), [Table 12](#)) or a short circuit.

The clamping function is enabled, when the clamp bit is set.

Table 11 Clamping Ranges

Parameter	Symbol	Limit Values		Unit	Notes
		min.	max.		
Clamping voltage low	$V_{CL,low}$	8	12	%	of V_{DD} ¹⁾
Clamping voltage high	$V_{CL,high}$	88	92	%	of V_{DD} ¹⁾

¹⁾ $R_{LOAD} \geq 4.7 \text{ k}\Omega$

The following figure shows how the magnetic field range between B_{min} and B_{max} is mapped to voltages between 0.5 V and 4.5 V.

If it is not necessary to signal errors, the clamping should be disabled. In this case the maximum output voltage range between 0.3 V and 4.7 V can be used.

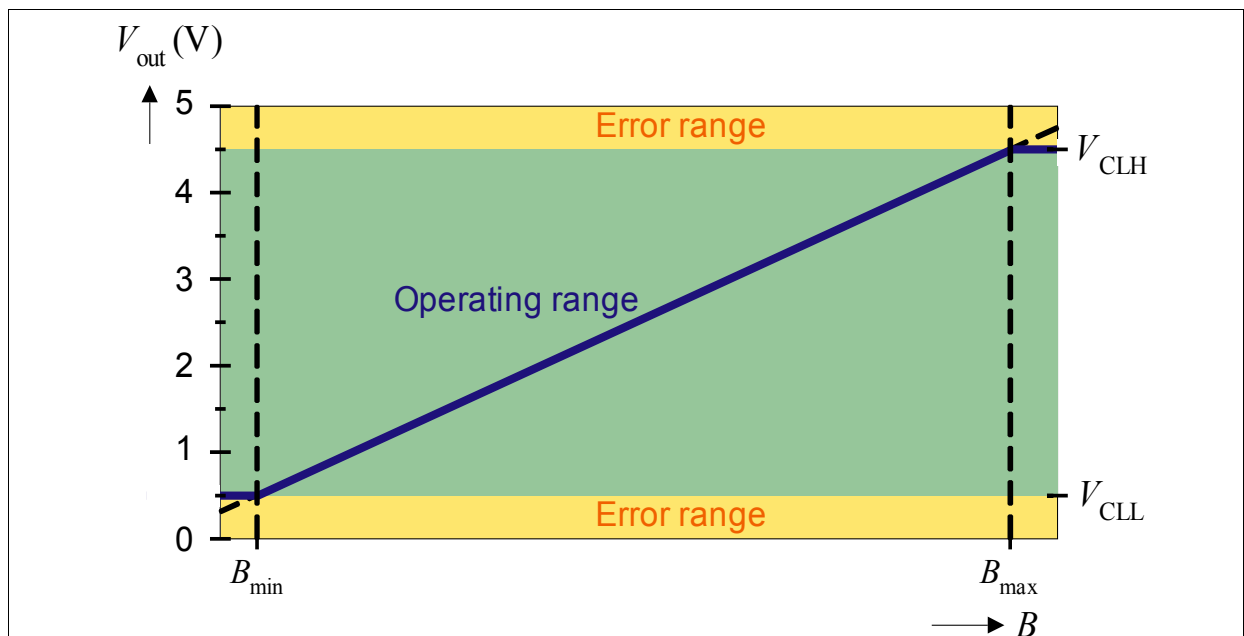

Figure 5 Clamping

7 Error Detection

Broken supply lines can be detected by the OBD (**O**n **B**oard **D**iagnostics) and reported to the μ Controller.

Note: The OBD is only useful when the clamping function is enabled.

In the case of interrupted supply lines, the μ Controller may warn the user.

If two sensors are placed in parallel, the output of the remaining working sensor may be still used for an emergency operation.

Table 12 Open Circuit (OBD parameters)

Parameter	Symbol	Limit Values		Unit	Notes
		min.	max.		
Output voltage @ Open V_{DD} line	V_{OUT}	0	6	% V_{DD}	1)
Output voltage @ Open V_{SS} line	V_{OUT}	94	100	% V_{DD}	1)

¹⁾ With $R_L \geq 7 \text{ k}\Omega$

8 Calibration and Fusing

Usually the sensor is calibrated 'End Of Line', when the complete magnetic system is assembled. This compensates all magnetic and mechanical tolerances.

Note: The -E6782 version is already programmed completely. The contents of the calibration OTP memory may not be changed furthermore.

During the calibration the internal settings are stored in a RAM. When the right values are found, the information has to be stored in an one-time-programmable memory (OTP).

This OTP memory consists of cavity fuses.

After fusing all bits, setting the MEMLOCK bit closes the memory. This prevents from unwanted memory changes after the calibration

Data Transfer Protocol

A separate programming specification may be requested.

Programming of Sensors with Common Supply Lines

In many automotive applications two sensors are used to measure the same parameter. This redundancy allows to continue the operation in an emergency mode. If both sensors use the same power supply lines, they have to be programmed together.

Sensor Interface Tool

For the calibration of the sensor, a special hardware interface to a PC is required.

9 Application Circuit

Figure 6 shows the connection of multiple sensors to a μ -Controller.

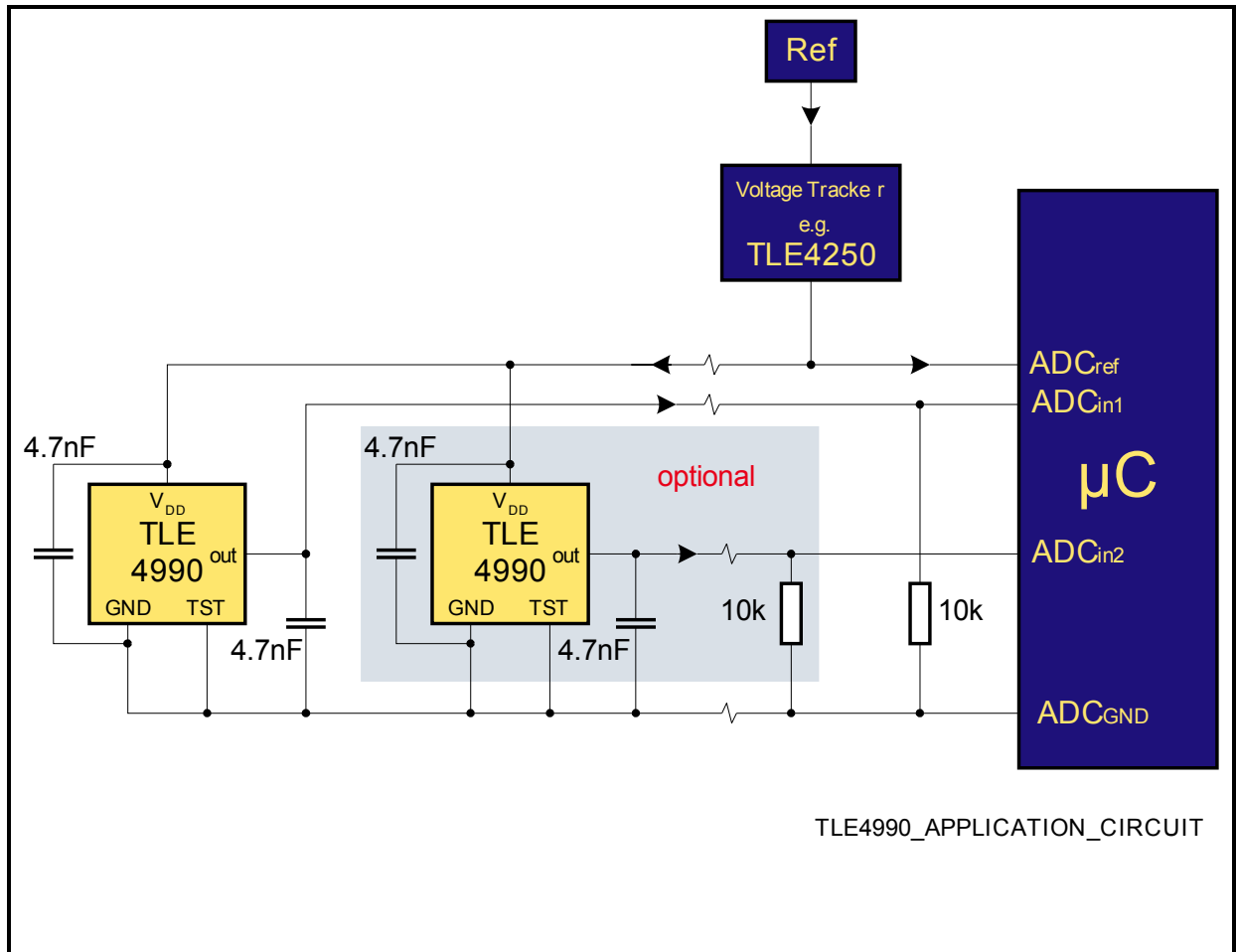

Figure 6 Application Circuit

10 Package Outlines

P-SSO-4-1

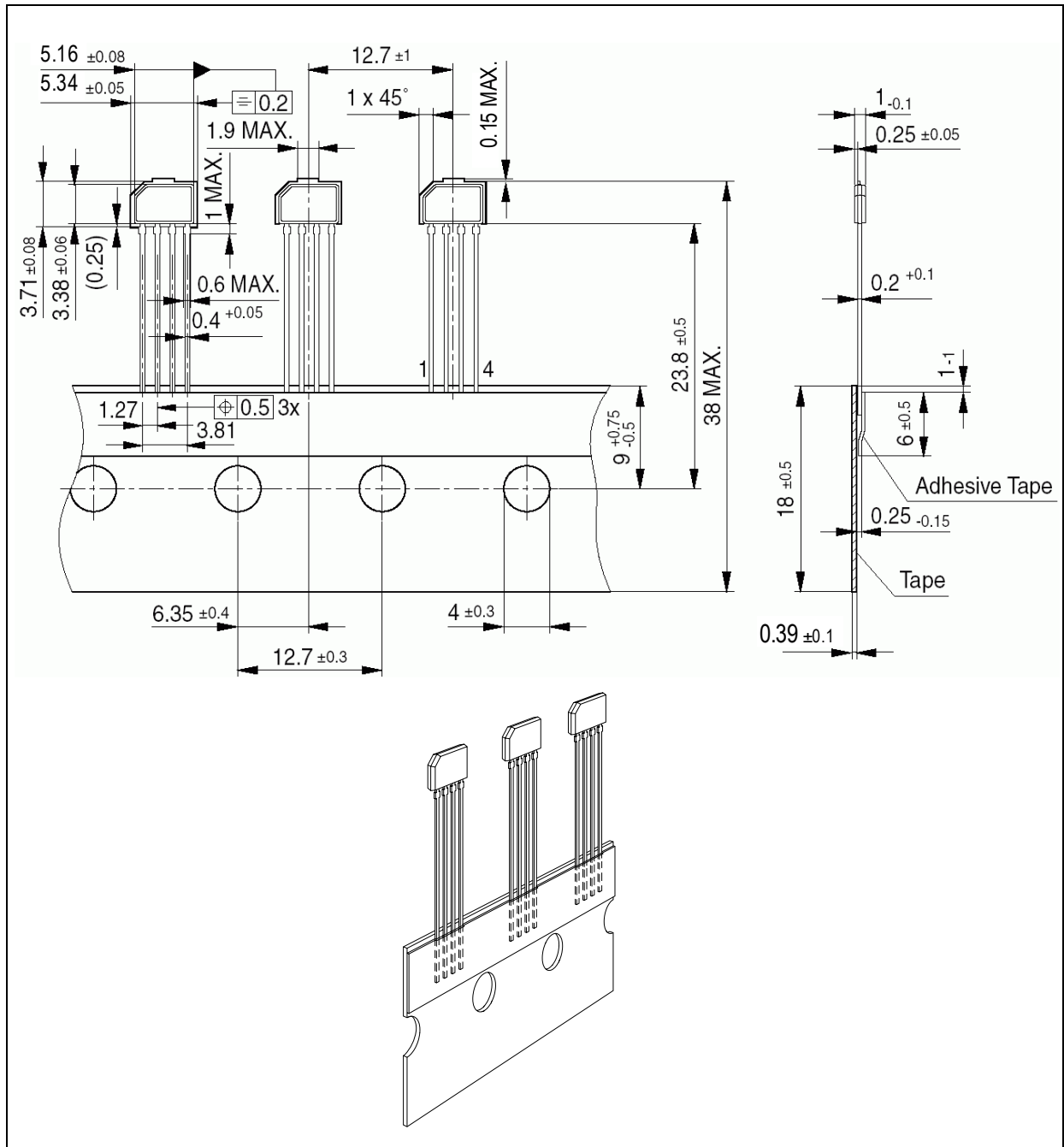

Figure 7 Package Outline



www.infineon.com

Published by Infineon Technologies AG