

# TLE4675

Low Drop Out Linear Voltage Regulator  
5V Fixed Output Voltage

Automotive Power



Never stop thinking

## Table of Contents

	<b>Table of Contents</b> .....	2
<b>1</b>	<b>Overview</b> .....	3
<b>2</b>	<b>Block Diagram</b> .....	4
<b>3</b>	<b>Pin Configuration</b> .....	5
3.1	Pin Assignment TLE4675D (PG-TO252-5) .....	5
3.2	Pin Definitions and Functions TLE4675D .....	5
3.3	Pin Assignment TLE4675G (PG-TO263-5) .....	6
3.4	Pin Definitions and Functions TLE4675G .....	6
<b>4</b>	<b>General Product Characteristics</b> .....	7
4.1	Absolute Maximum Ratings .....	7
4.2	Functional Range .....	8
4.3	Thermal Resistance .....	9
<b>5</b>	<b>Voltage Regulator</b> .....	10
5.1	Description Voltage Regulator .....	10
5.2	Electrical Characteristics Voltage Regulator .....	11
5.3	Typical Performance Characteristics Voltage Regulator .....	12
<b>6</b>	<b>Current Consumption</b> .....	14
6.1	Electrical Characteristics Current Consumption .....	14
6.2	Typical Performance Characteristics Current Consumption .....	15
<b>7</b>	<b>Reset Function</b> .....	16
7.1	Description Reset Function .....	16
7.2	Electrical Characteristics Reset Function .....	20
7.3	Typical Performance Characteristics Reset Function .....	21
<b>8</b>	<b>Package Outlines</b> .....	22
8.1	PG-TO252-5 Package .....	22
8.2	PG-TO263-5 Package .....	23
<b>9</b>	<b>Revision History</b> .....	24



## 1 Overview

### Features

- Output Voltage  $5\text{ V} \pm 2\%$
- Output Current Capability 400 mA
- Ultra Low Current Consumption
- Very Low Drop Out Voltage
- Reset Circuit Sensing the Output Voltage with Programmable Delay Time
- Reset Output Active Low Down to  $V_Q = 1\text{ V}$
- Excellent Line Transient Robustness
- Maximum Input Voltage  $-42\text{ V} \leq V_I \leq +45\text{ V}$
- Reverse Polarity Protection
- Short Circuit Protected
- Overtemperature Shutdown
- Automotive Temperature Range  $-40\text{ }^\circ\text{C} \leq T_j \leq 150\text{ }^\circ\text{C}$
- Green Product (RoHS compliant)
- AEC Qualified

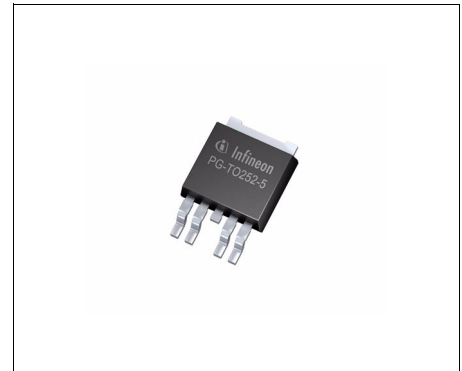

**PG-TO252-5**

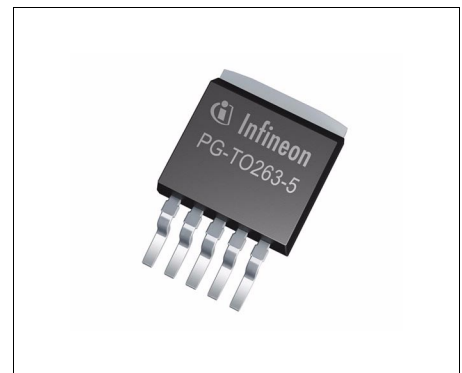

**PG-TO263-5**

### Description

The TLE4675 is a monolithic integrated low drop out fixed output voltage regulator for loads up to 400 mA. An input voltage up to 45 V is regulated to an output voltage of 5 V. The integrated reset function, as well as several protection circuits combined with the wide operating temperature range offered by the TLE4675 make it suitable for supplying microprocessor system in automotive environments.

Type	Package	Marking
TLE4675D	PG-TO252-5	TLE4675
TLE4675G	PG-TO263-5	TLE4675

## 2 Block Diagram

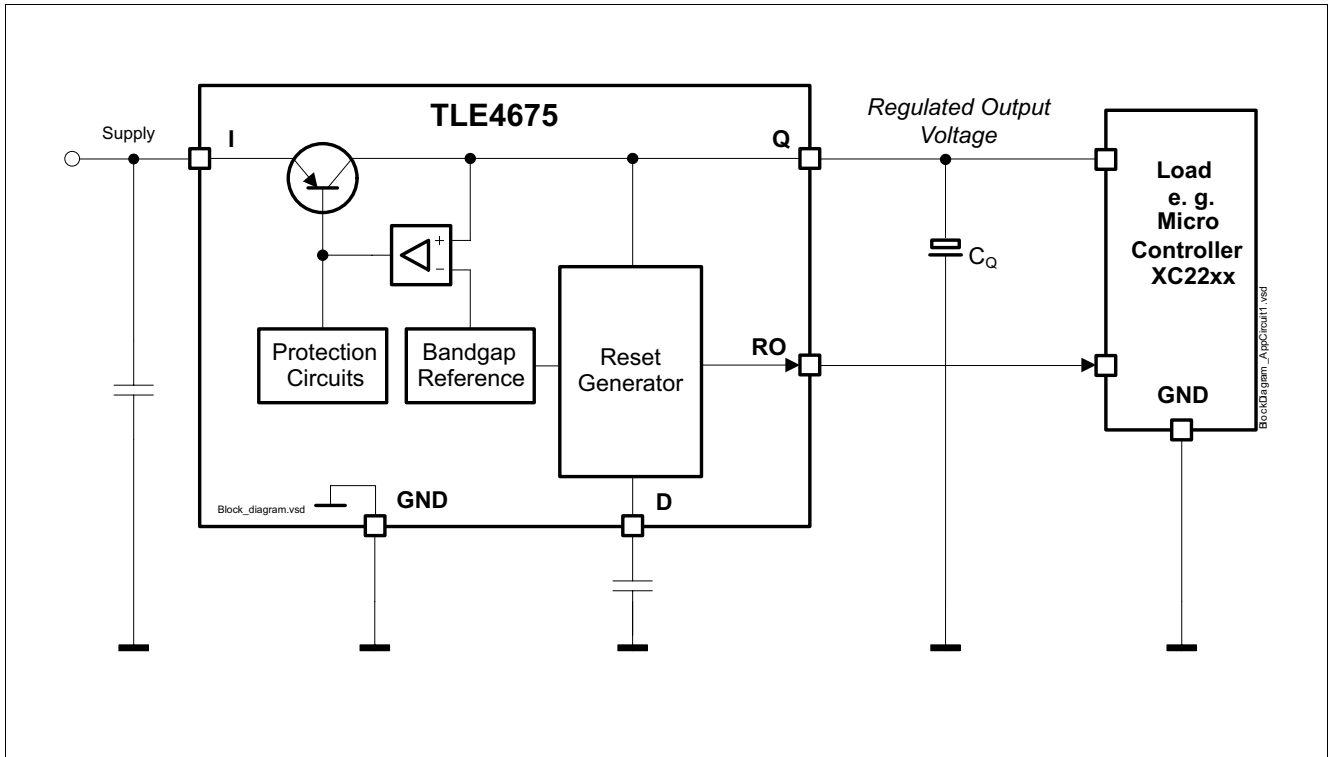

Figure 1 Block Diagram and Simplified Application Circuit

### 3 Pin Configuration

#### 3.1 Pin Assignment TLE4675D (PG-TO252-5)

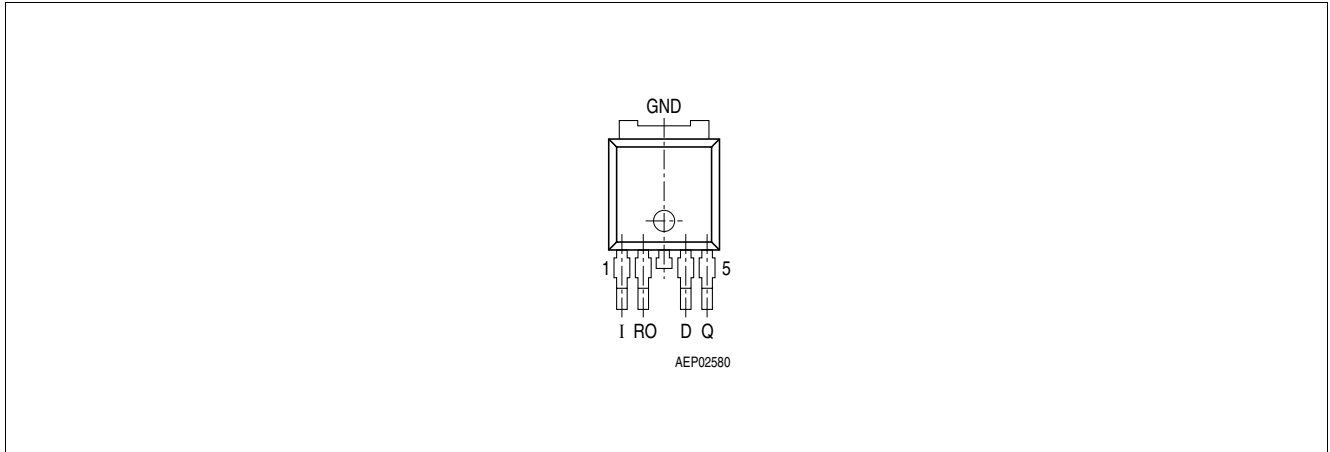

Figure 2 Pin Assignment (top view) TLE4675D

#### 3.2 Pin Definitions and Functions TLE4675D

Pin	Symbol	Function
1	I	<b>Regulator Input and IC Supply</b> For compensating line influences, a capacitor to GND close to the IC pin is recommended.
2	RO	<b>Reset Output</b> Open collector output; external pull up resistor required; Leave open if the reset function is not needed.
3		Internally connected to TAB
4	D	<b>Reset Delay Timing</b> Connect a ceramic capacitor from D (Pin 4) to GND for the reset delay timing adjustment; Leave open, if reset functionality is not used.
5	Q	<b>5 V Regulator Output</b> Connect a capacitor between Q (Pin 5) and GND close to the IC pins, respecting capacitance and ESR requirements given in the <a href="#">Chapter 4.2 Functional Range</a> .
TAB	GND	<b>Ground, Cooling TAB</b> Connect to heatsink area

### 3.3 Pin Assignment TLE4675G (PG-TO263-5)

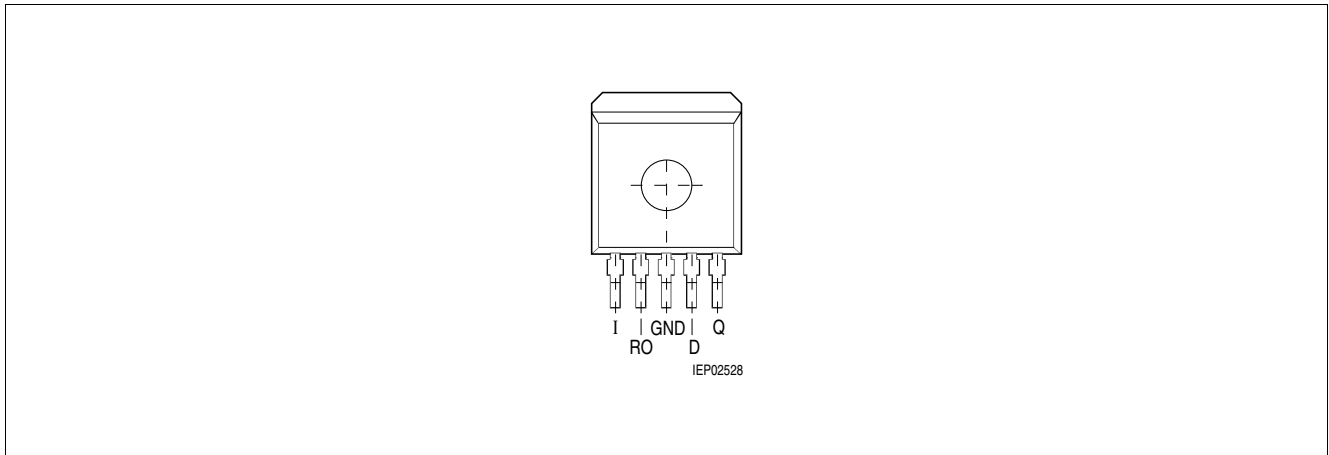

Figure 3 Pin Assignment (top view) TLE4675G

### 3.4 Pin Definitions and Functions TLE4675G

Pin	Symbol	Function
1	I	<b>Regulator Input and IC Supply</b> For compensating line influences, a capacitor to GND close to the IC pin is recommended
2	RO	<b>Reset Output</b> Open collector output; external pull up resistor required; Leave open if the reset function is not needed
3	GND	<b>Ground</b> Internally connected to TAB
4	D	<b>Reset Delay Timing</b> Connect a ceramic capacitor from D (Pin 4) to GND for the reset delay timing adjustment; leave open, if reset functionality is not used
5	Q	<b>5 V Regulator Output</b> Connect a capacitor between Q (Pin 5) and GND close to the IC pins, respecting capacitance and ESR requirements given in the <a href="#">Chapter 4.2 Functional Range</a>
TAB		<b>Cooling TAB</b> Connect to heatsink area and Ground

## 4 General Product Characteristics

### 4.1 Absolute Maximum Ratings

#### Absolute Maximum Ratings <sup>1)</sup>

$T_j = -40\text{ °C}$  to  $+150\text{ °C}$ ; all voltages with respect to ground, positive current flowing into pin  
(unless otherwise specified)

Pos.	Parameter	Symbol	Limit Values		Unit	Conditions
			Min.	Max.		
<b>Voltages</b>						
4.1.1	Regulator Input and IC Supply I	$V_I$	-42	45	V	–
4.1.2	Regulator Output Q	$V_Q$	-1	7	V	–
4.1.3	Reset Output RO	$V_{RO}$	-0.3	7	V	–
4.1.4	Reset Delay Timing D	$V_D$	-0.3	7	V	–
<b>Temperatures</b>						
4.1.5	Junction Temperature	$T_j$	-40	150	°C	–
4.1.6	Storage Temperature	$T_{stg}$	-55	150	°C	–
<b>ESD Susceptibility</b>						
4.1.7	ESD Resistivity	$V_{ESD,HBM}$	-4	4	kV	Human Body Model <sup>2)</sup>
4.1.8		$V_{ESD,CDM}$	-1	1	kV	Charged Device Model <sup>3)</sup>

1) Not subject to production test, specified by design.

2) ESD susceptibility, HBM according to AEC-Q100-002 - JESD22-A114

3) ESD susceptibility, Charged Device Model "CDM" ESDA STM5.3.1

*Note: Stresses above the ones listed here may cause permanent damage to the device. Exposure to absolute maximum rating conditions for extended periods may affect device reliability.*

*Note: Integrated protection functions are designed to prevent IC destruction under fault conditions described in the data sheet. Fault conditions are considered as "outside" normal operating range. Protection functions are not designed for continuous repetitive operation.*

## 4.2 Functional Range

Pos.	Parameter	Symbol	Limit Values		Unit	Conditions
			Min.	Max.		
4.2.1	Input Voltage Range for Normal Operation	$V_{I(nor)}$	$V_Q + V_{dr}$	45	V	<sup>1)</sup>
4.2.2	Extended Input Voltage Range	$V_{I(ext)}$	3.3	45	V	<sup>2)</sup>
4.2.3	Input Voltage Transient Immunity	$dV_I/dt$	-10	20	V/ $\mu$ s	$dV_I \leq 10$ V; $V_I > 9$ V; No trigger of RO. <sup>3)</sup>
4.2.4	Junction Temperature	$T_j$	-40	150	$^{\circ}$ C	–
4.2.5	Output Capacitor	$C_Q$	22	–	$\mu$ F	– <sup>4)</sup>
4.2.6	Requirements	$ESR_{CQ}$	–	2.5	$\Omega$	– <sup>5)</sup>

1) For specification of the input voltage  $V_Q$  and the drop out voltage  $V_{dr}$  see [Chapter 5 Voltage Regulator](#).

2) The output voltage  $V_Q$  will follow the input voltage, but is outside the specified range.  
For details see [Chapter 5 Voltage Regulator](#).

3) Transient measured directly at the input pin. Not subject to production test, specified by design.

4) The minimum output capacitance requirement is applicable for a worst case capacitance tolerance of 30%

5) Relevant ESR value at  $f = 10$  kHz

*Note: Within the functional range the IC operates as described in the circuit description. The electrical characteristics are specified within the conditions given in the related electrical characteristics table.*



### 4.3 Thermal Resistance

Note: This thermal data was generated in accordance with JEDEC JESD51 standards. For more information, go to [www.jedec.org](http://www.jedec.org).

Pos.	Parameter	Symbol	Limit Values			Unit	Conditions
			Min.	Typ.	Max.		
<b>TLE4675D Package PG-TO252-5</b>							
4.3.1	Junction to Case	$R_{thJC}$	–	3.7	–	K/W	<sup>1)</sup>
4.3.2	Junction to Ambient	$R_{thJA}$	–	110	–	K/W	Footprint only <sup>1)2)</sup>
4.3.3			–	57	–	K/W	300 mm <sup>2</sup> heatsink area on PCB <sup>1)2)</sup>
4.3.4			–	42	–	K/W	600 mm <sup>2</sup> heatsink area on PCB <sup>1)2)</sup>
4.3.5			–	27	–	K/W	2s2p PCB <sup>1)3)</sup>
<b>TLE4675G Package PG-TO263-5</b>							
4.3.6	Junction to Case	$R_{thJC}$	–	3.7	–	K/W	<sup>1)</sup>
4.3.7	Junction to Ambient	$R_{thJA}$	–	123	–	K/W	Footprint only <sup>1)2)</sup>
4.3.8			–	42	–	K/W	300 mm <sup>2</sup> PCB heatsink area <sup>1)2)</sup>
4.3.9			–	33	–	K/W	600 mm <sup>2</sup> PCB heatsink area <sup>1)2)</sup>
4.3.10			–	22	–	K/W	2s2p PCB <sup>1)3)</sup>

1) Not subject to production test, specified by design

2) Specified  $R_{thJA}$  value is according to JEDEC JESD 51-3 at natural convection on FR4 1s0p board; The Product (Chip+Package) was simulated on a 76.2 × 114.3 × 1.5 mm<sup>3</sup> board with 1 copper layer (1 × 70μm Cu).

3) Specified  $R_{thJA}$  value is according to Jedec JESD51-2,-5,-7 at natural convection on FR4 2s2p board; The Product (Chip+Package) was simulated on a 76.2 × 114.3 × 1.5 mm<sup>3</sup> board with 2 inner copper layers (2 × 70μm Cu, 2 × 35μm Cu). Where applicable a thermal via array under the exposed pad contacted the first inner copper layer.

## 5 Voltage Regulator

### 5.1 Description Voltage Regulator

The output voltage  $V_Q$  is controlled by comparing a portion of it to an internal reference and driving a PNP pass transistor accordingly. Saturation control as a function of the load current prevents any oversaturation of the pass element. The control loop stability depends on the output capacitor  $C_Q$ , the load current, the chip temperature and the poles/zeros introduced by the integrated circuit. To ensure stable operation, the output capacitor's capacitance and its equivalent series resistor ESR requirements given in the table "Operating Range" have to be maintained. For details see also the typical performance graph "Output Capacitor Series Resistor  $ESR_{CQ}$  vs. Output Current  $I_Q$ ". Also, the output capacitor shall be sized to buffer load transients.

An input capacitor  $C_I$  is not needed for the control loop stability, but recommended to buffer line influences. Connect the capacitors close to the IC terminals.

Protection circuitry prevent the IC as well as the application from destruction in case of catastrophic events. These safeguards contain output current limitation, reverse polarity protection as well as thermal shutdown in case of overtemperature.

In order to avoid excessive power dissipation that could never be handled by the pass element and the package, the maximum output current is decreased at input voltages above  $V_I = 22\text{ V}$ .

The thermal shutdown circuit prevents the IC from immediate destruction under fault conditions (e.g. output continuously short-circuited) by switching off the power stage. After the chip has cooled down, the regulator restarts. This leads to an oscillatory behavior of the output voltage until the fault is removed. However, junction temperatures above  $150\text{ }^\circ\text{C}$  are outside the maximum ratings and therefore reduce the IC lifetime.

The TLE4675 allows a negative supply voltage. However, several small currents are flowing into the IC increasing its junction temperature. This has to be considered for the thermal design, respecting that the thermal protection circuit is not operating during reverse polarity condition.

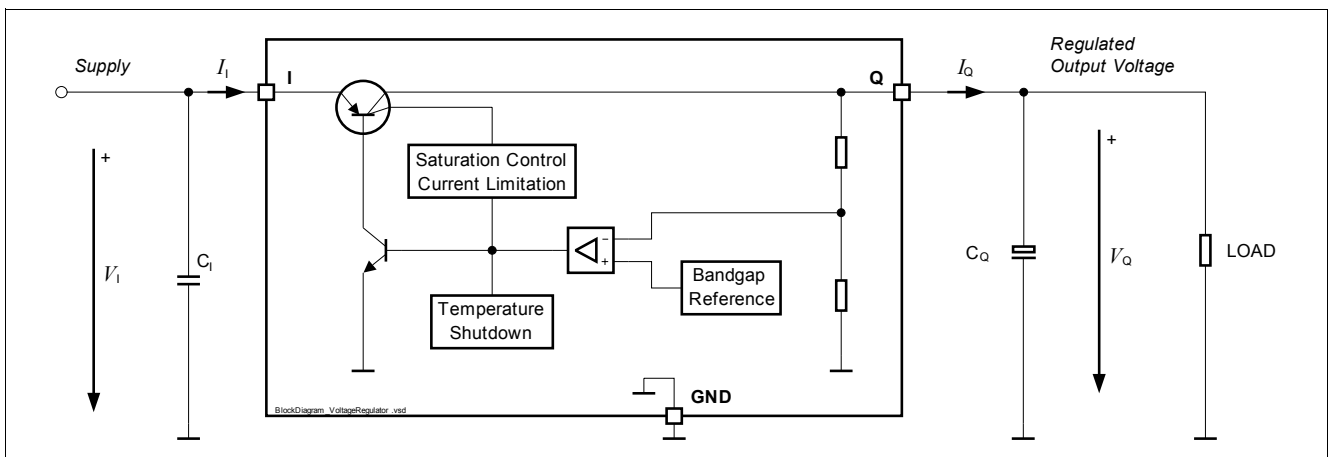

Figure 4 Block Diagram Voltage Regulator Circuit

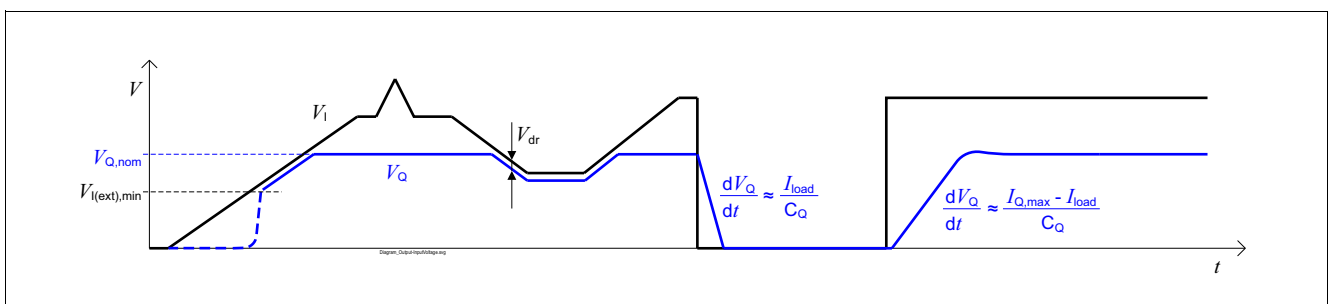

Figure 5 Output Voltage vs. Input Voltage

## 5.2 Electrical Characteristics Voltage Regulator

### Electrical Characteristics: Voltage Regulator

 $V_1 = 13.5 \text{ V}$ ,  $T_j = -40 \text{ }^\circ\text{C}$  to  $+150 \text{ }^\circ\text{C}$ ,

 all voltages with respect to ground, direction of currents as shown in [Figure](#) (unless otherwise specified)

Pos.	Parameter	Symbol	Limit Values			Unit	Conditions
			Min.	Typ.	Max.		
5.2.1	Output Voltage	$V_Q$	4.9	5.0	5.1	V	$200 \mu\text{A} \leq I_Q \leq 400 \text{ mA}$ ; $8 \text{ V} \leq V_1 \leq 18 \text{ V}$
5.2.2			4.9	5.0	5.1	V	$200 \mu\text{A} \leq I_Q \leq 300 \text{ mA}$ ; $6 \text{ V} \leq V_1 \leq 18 \text{ V}$
5.2.3			4.9	5.0	5.1	V	$200 \mu\text{A} \leq I_Q \leq 200 \text{ mA}$ ; $18 \text{ V} \leq V_1 \leq 32 \text{ V}^{1)}$
5.2.4			4.9	5.0	5.1	V	$200 \mu\text{A} \leq I_Q \leq 20 \text{ mA}$ ; $32 \text{ V} \leq V_1 \leq 45 \text{ V}^{1)}$
5.2.5	Load Regulation steady-state	$dV_{Q,\text{load}}$	-30	-5	–	mV	$I_Q = 1 \text{ mA}$ to $300 \text{ mA}$ ; $V_1 = 6 \text{ V}$
5.2.6	Line Regulation steady-state	$dV_{Q,\text{line}}$	–	5	20	mV	$V_1 = 6 \text{ V}$ to $32 \text{ V}$ ; $I_Q = 5 \text{ mA}$
5.2.7	Power Supply Ripple Rejection	$PSRR$	60	65	–	dB	$f_{\text{ripple}} = 100 \text{ Hz}$ ; $V_{\text{ripple}} = 1 \text{ Vpp}^{2)}$
5.2.8	Drop Out Voltage $V_{\text{dr}} = V_1 - V_Q$	$V_{\text{dr}}$	–	120	250	mV	$I_Q = 100 \text{ mA}^{3)}$
5.2.9			–	250	500	mV	$I_Q = 300 \text{ mA}^{3)}$
5.2.10	Output Current Limitation	$I_{Q,\text{max}}$	401	550	850	mA	$0 \text{ V} \leq V_Q \leq 4.8 \text{ V}$
5.2.11	Reverse Current	$I_Q$	-2	-1	–	mA	$V_1 = 0 \text{ V}$ ; $V_Q = 5 \text{ V}$
5.2.12	Reverse Current at Negative Input Voltage	$I_1$	-5	-2	–	mA	$V_1 = -16 \text{ V}$ ; $V_Q = 0 \text{ V}$
5.2.13			-10	-3	–	mA	$V_1 = -42 \text{ V}$ ; $V_Q = 0 \text{ V}$
5.2.14	Overtemperature Shutdown Threshold	$T_{j,\text{sd}}$	151	–	200	$^\circ\text{C}$	$T_j$ increasing <sup>2)</sup>
5.2.15	Overtemperature Shutdown Threshold Hysteresis	$T_{j,\text{hy}}$	–	25	–	K	$T_j$ decreasing <sup>2)</sup>

1) See typical performance graph for details.

2) Parameter not subject to production test; specified by design.

 3) Measured when the output voltage  $V_Q$  has dropped 100 mV from its nominal value.

### 5.3 Typical Performance Characteristics Voltage Regulator

Output Voltage  $V_Q$  vs. Junction Temperature  $T_j$

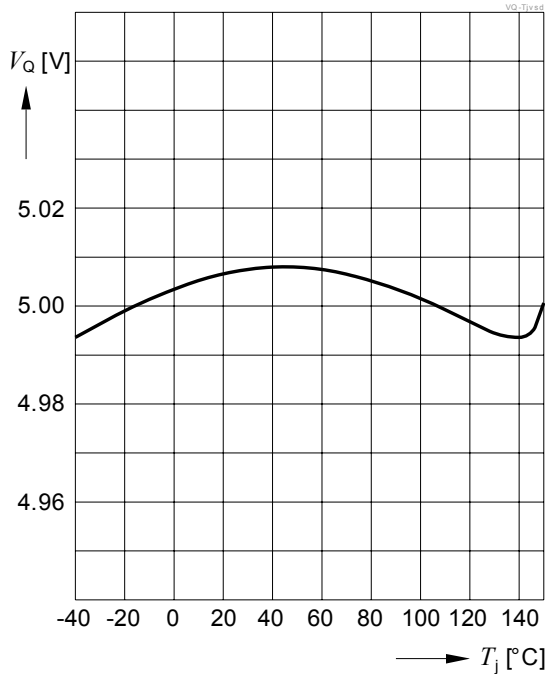

Output Capacitor Series Resistor  $ESR_{CQ}$  vs. Output Current  $I_Q$

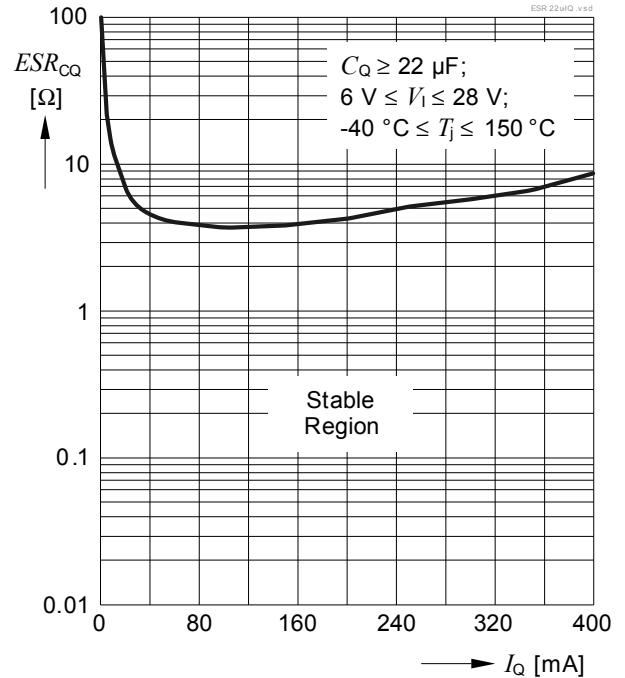

Output Current Limitation  $I_{Q,max}$  vs. Input Voltage  $V_1$

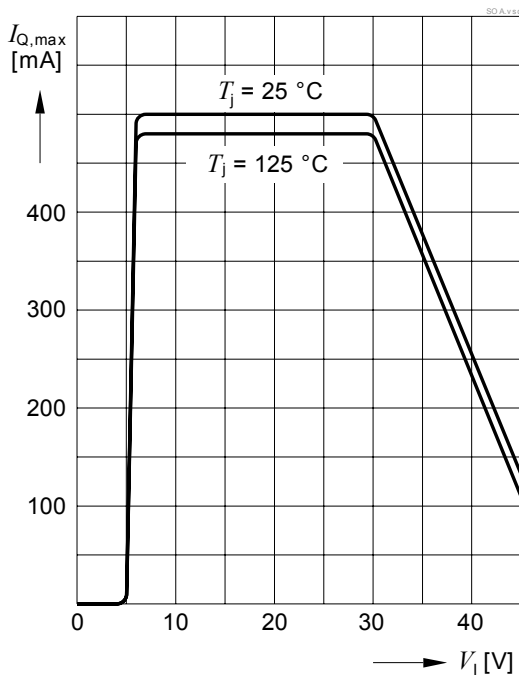

Power Supply Ripple Rejection  $PSRR$

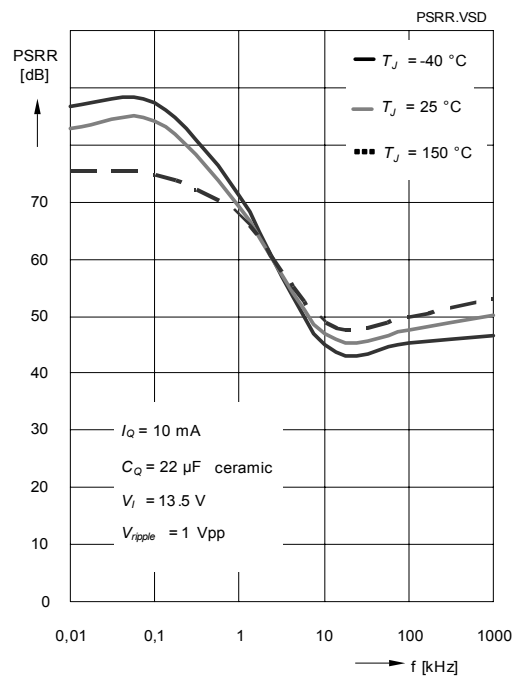

Dropout Voltage  $V_{dr}$  vs. Output Current  $I_Q$

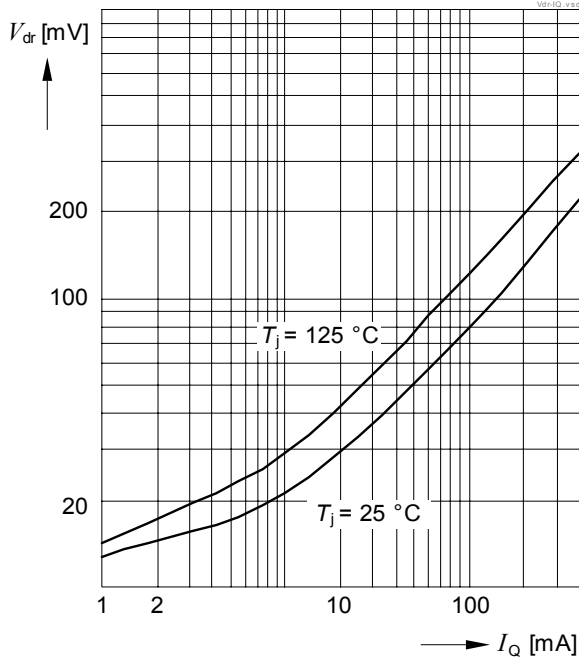

Dropout Voltage  $V_{dr}$  vs. Junction Temperature  $T_j$

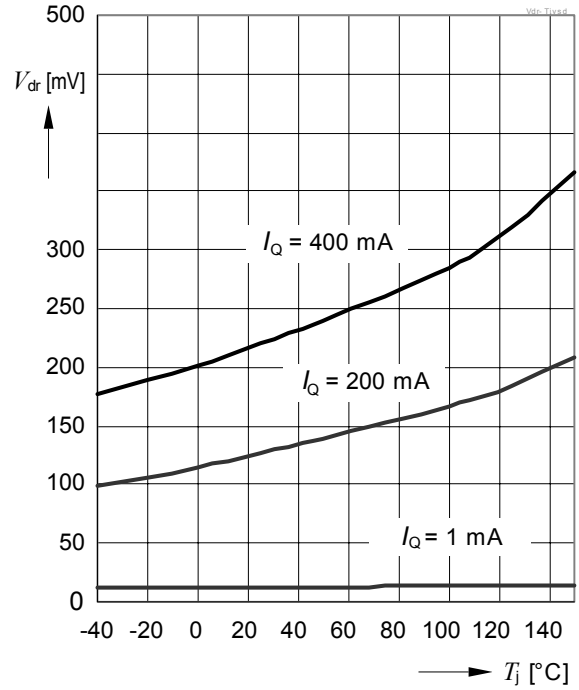

Reverse Output Current  $I_Q$  vs. Input Voltage  $V_Q$

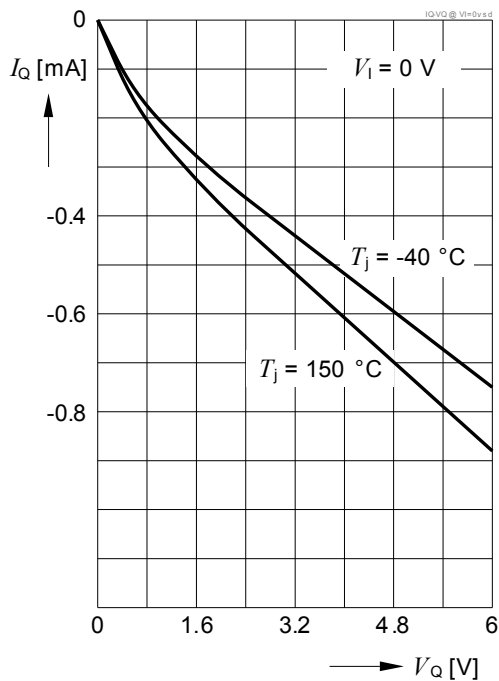

Reverse Current  $I_I$  vs. Input Voltage  $V_I$

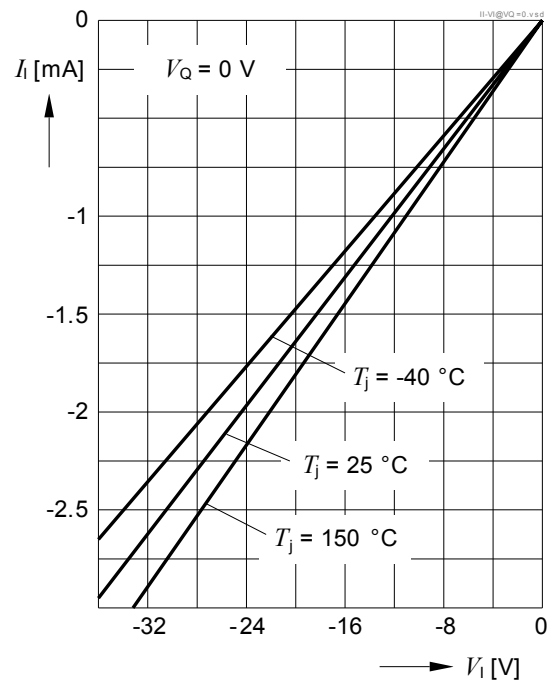

## 6 Current Consumption

### 6.1 Electrical Characteristics Current Consumption

#### Electrical Characteristics: Current Consumption

$V_I = 13.5\text{ V}$ ,  $T_j = -40\text{ °C}$  to  $+150\text{ °C}$ ,

all voltages with respect to ground, directions of currents as shown in **Figure 6** (unless otherwise specified)

Pos.	Parameter	Symbol	Limit Values			Unit	Conditions
			Min.	Typ.	Max.		
6.1.1	Current Consumption	$I_q$	–	65	80	$\mu\text{A}$	$I_Q \leq 200\ \mu\text{A}$ ; $T_j \leq 25\text{ °C}$
6.1.2	$I_q = I_I - I_Q$		–	70	85	$\mu\text{A}$	$I_Q \leq 200\ \mu\text{A}$ ; $T_j \leq 85\text{ °C}$
6.1.3			–	6	10	$\text{mA}$	$I_Q = 250\ \text{mA}$
6.1.4			–	15	25	$\text{mA}$	$I_Q = 400\ \text{mA}$

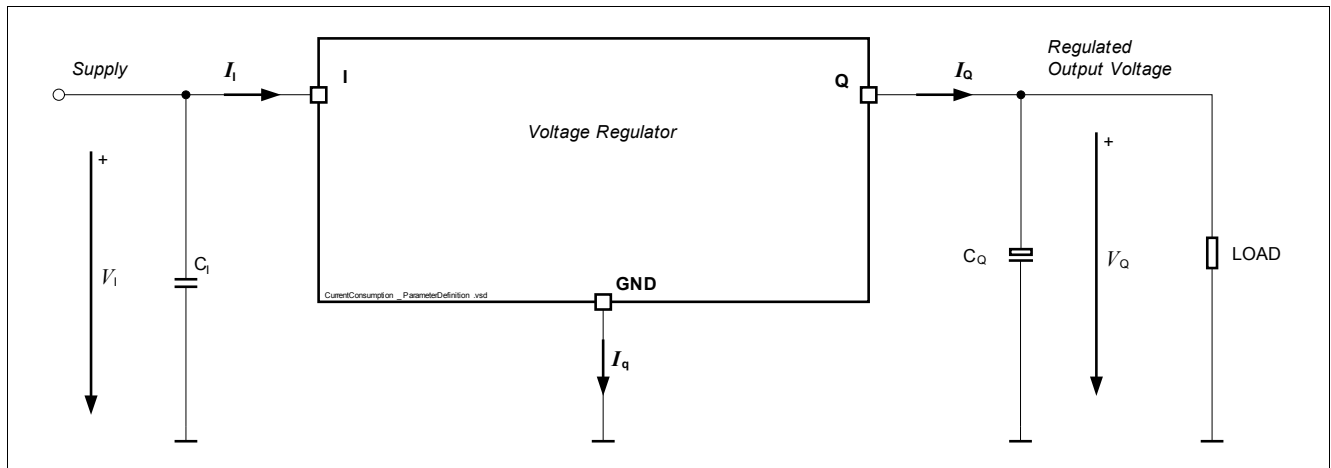
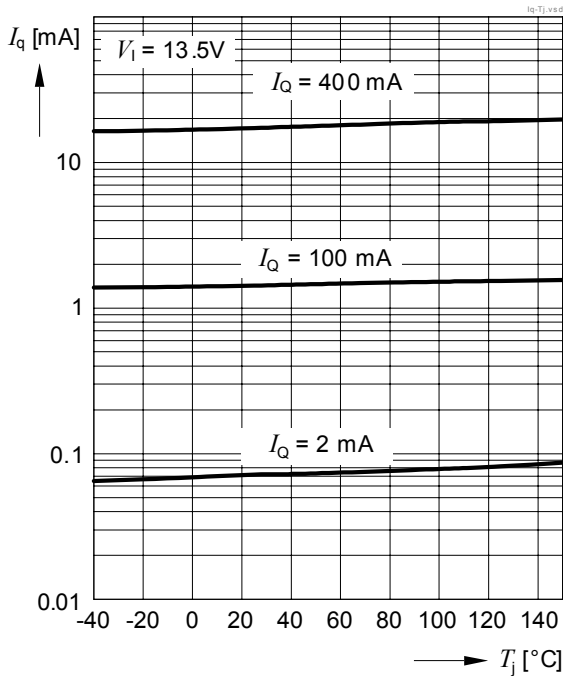

Figure 6 Parameter Definition

## 6.2 Typical Performance Characteristics Current Consumption

Current Consumption  $I_q$  vs. Junction Temperature  $T_j$



Current Consumption  $I_q$  vs. Junction Temperature  $T_j$

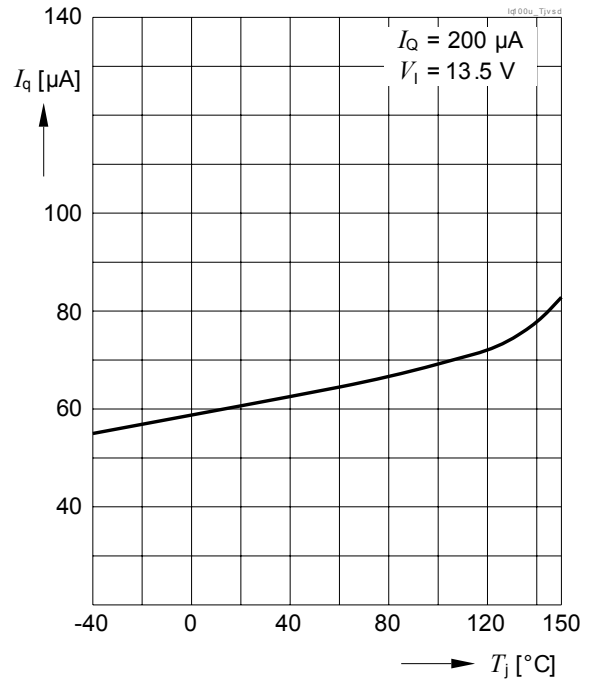

Current Consumption  $I_q$  vs. Output Current  $I_Q$

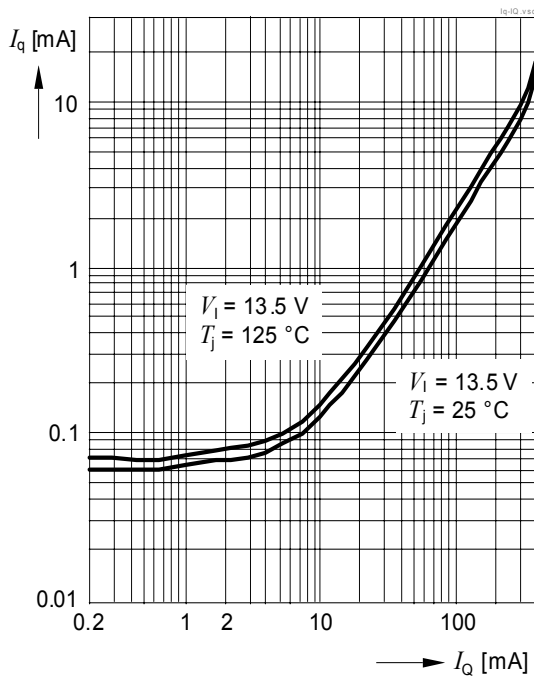

Current Consumption  $I_q$  vs. Input Voltage  $V_1$

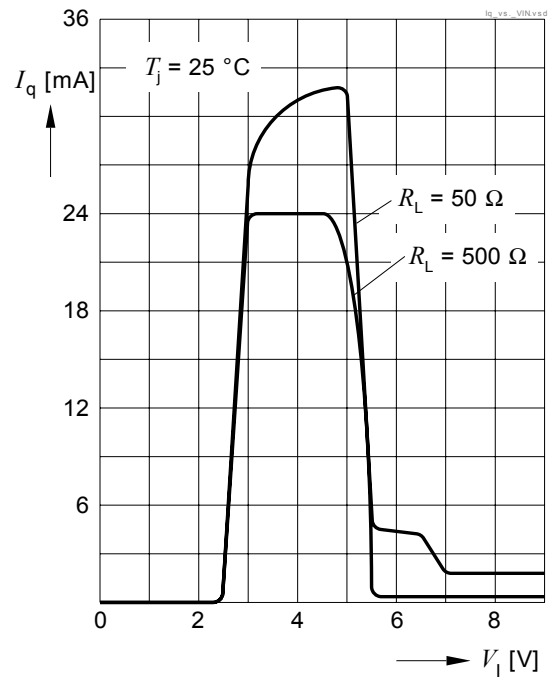

## 7 Reset Function

### 7.1 Description Reset Function

The reset function contains several features:

#### Output Undervoltage Reset:

An output undervoltage condition is indicated by setting the reset output “RO” to “low”. This signal might be used to reset a microcontroller during a low supply voltage condition.

#### Power-On Reset Delay Time

The power-on reset delay time  $t_{d,PWR-ON}$  allows a microcontroller and oscillator to start up. This delay time is the time period from exceeding the upper reset switching threshold  $V_{RT,hi}$  until the reset is released by switching the reset output “RO” from “low” to “high”. The power-on reset delay time  $t_{d,PWR-ON}$  is defined by an external delay capacitor  $C_D$  connected to pin “D”, which is charged up by the delay capacitor charge current  $I_{D,ch}$  starting from  $V_D = 0$  V.

In case a power-on reset delay time  $t_{d,PWR-ON}$  different from the value for  $C_D = 100$ nF is required, the delay capacitor’s value can be derived from the specified value given in [Item 7.2.15](#):

$$C_D = \frac{t_{d,PWR-ON}}{t_{d,PWR-ON,100nF}} \times 100\text{nF}$$

with

- $t_{d,PWR-ON}$ : Desired power-on reset delay time
- $t_{d,PWR-ON,100nF}$ : Power-on reset delay time specified in [Item 7.2.15](#)
- $C_D$ : Delay capacitor required

The formula is valid for  $C_D \geq 10$ nF. For a precise calculation consider also the delay capacitor’s tolerance.

#### Undervoltage Reset Delay Time

Unlike the power-on reset delay time, the undervoltage reset delay  $t_d$  time considers a short output undervoltage event, where the delay capacitor  $C_D$  is assumed to be discharged to  $V_D = V_{DST,lo}$  only before the charging sequence starts. Therefore, the undervoltage reset delay time  $t_d$  is defined by the delay capacitor charge current  $I_{D,ch}$  starting from  $V_D = V_{DST,lo}$  and the external delay capacitor  $C_D$ .

A delay capacitor  $C_D$  for a different undervoltage reset delay time as specified in [Item 7.2.14](#) can be calculated similar as above:

$$C_D = \frac{t_d}{t_{d,100nF}} \times 100\text{nF}$$

with

- $t_d$ : Desired reset delay time
- $t_{d,100nF}$ : Reset delay time specified in [Item 7.2.14](#)
- $C_D$ : Delay capacitor required

The formula is valid for  $C_D \geq 10$ nF. For a precise calculation consider also the delay capacitor’s tolerance.



### Reset Reaction Time

In case the output voltage of the regulator drops below the output undervoltage lower reset threshold  $V_{RT,lo}$ , the delay capacitor CD is discharged rapidly. Once the delay capacitor's voltage has reached the lower delay switching threshold  $V_{DST,lo}$ , the reset output RO will be set to "low".

Additionally to the delay capacitor discharge time  $t_{rr,d}$  an internal time  $t_{rr,int}$  applies. Hence the total reset reaction time  $t_{rr,total}$  becomes:

$$t_{rr,total} = t_{rr,int} + t_{rr,d}$$

with

- $t_{rr,total}$ : total reset reaction time
- $t_{rr,int}$ : Internal reset reaction time; see [Item 7.2.16](#)
- $t_{rr,d}$ : Delay capacitor discharge time. For a capacitor  $C_D$  different from the value specified in [Item 7.2.17](#), see typical performance graphs.

### Reset Output Pull-Up Resistor $R_{RO}$ :

The Reset Output RO is an open collector output requiring an external pull-up resistor to a voltage  $V_{IO}$ , e.g.  $V_Q$ . In [Item 7.2.7](#) a minimum value for the external resistor  $R_{RO}$  is given for the case it is connected to  $V_Q$ .

For applications, where the external pull-up resistor  $R_{RO}$  has to be connected to a different voltage rail  $V_{IO}$  than  $V_Q$ , the minimum pull-up resistor  $R_{RO}$  can be calculated out of the minimum sink current capability given in [Item 7.2.6](#):

$$R_{RO} = \frac{V_{IO} - V_{RO,low}}{I_{RO,max}}$$

with

- $R_{RO}$ : Reset pull up resistor
- $V_{IO}$ : Voltage rail, where the pull up resistor is connected
- $V_{RO,low}$ : Maximum allowed voltage level for a logic "Low" signal inside the application

Please be aware, that  $V_{IO}$  should not exceed the ratings for the RO pin given in [Item 4.1.3](#).

### Reset Output "RO" Low for $V_Q \geq 1$ V

In case of an undervoltage reset condition reset output "RO" is held "low" for  $V_Q \geq 1$  V, even if the input voltage  $V_I$  is 0 V. This is achieved by supplying the reset circuit from the output capacitor.

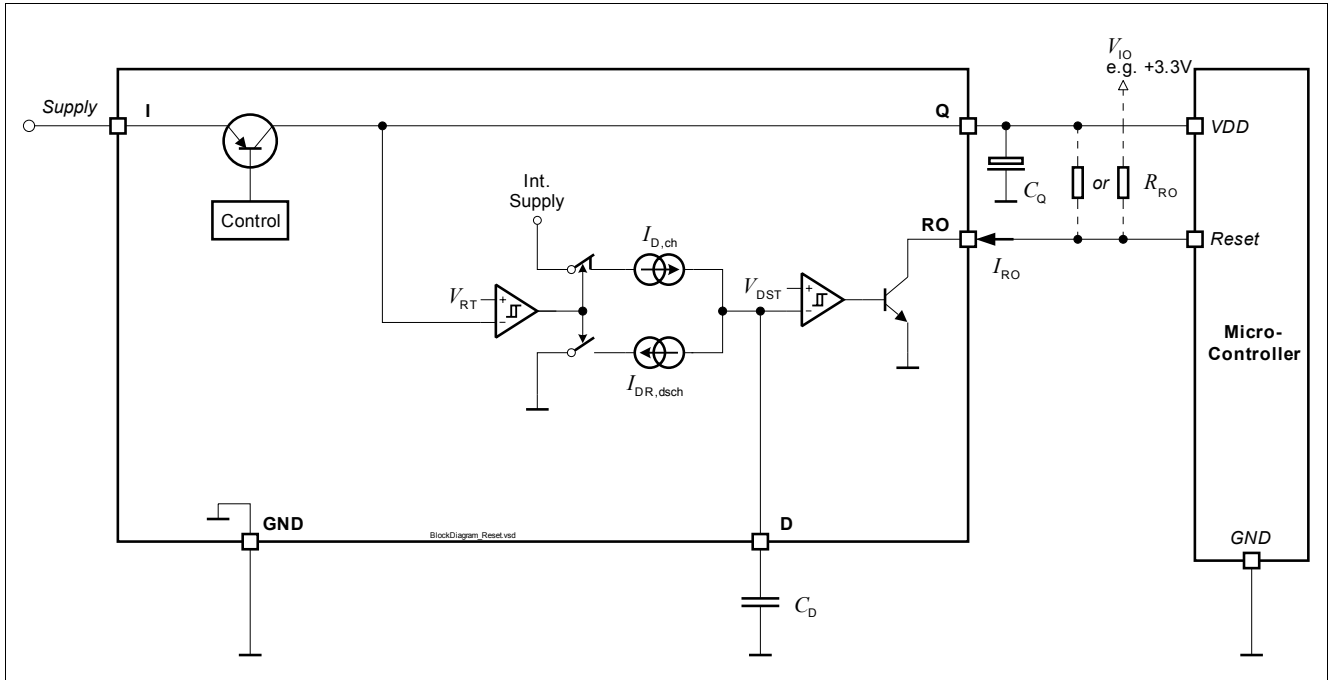
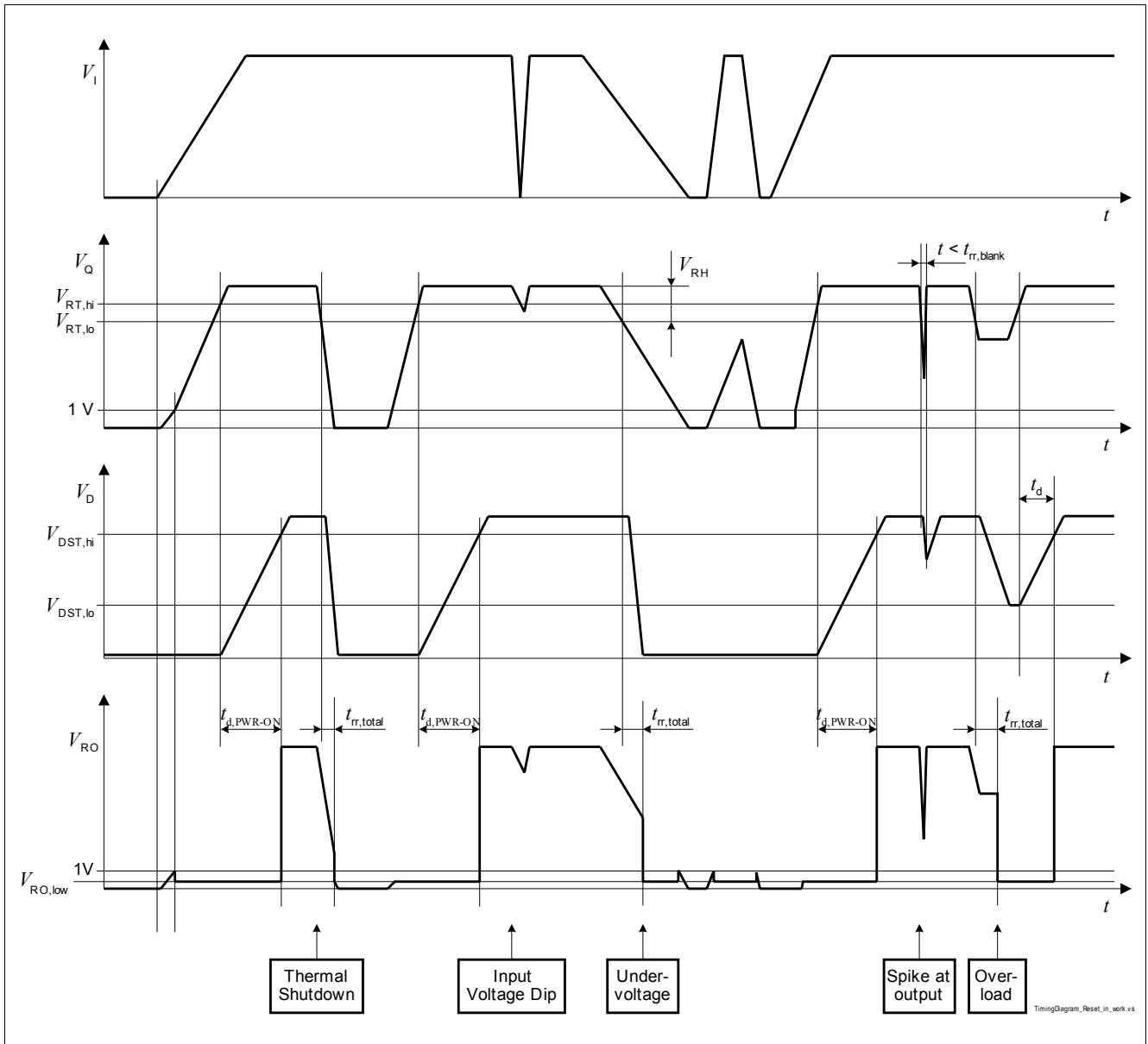

Figure 7 Block Diagram Reset Circuit



**Figure 8 Timing Diagram Reset**

The timing diagram assumes that the external pull up resistor  $R_{RO}$  is connected to the output voltage  $V_Q$ .

## 7.2 Electrical Characteristics Reset Function

### Electrical Characteristics: Reset Function

$V_I = 13.5\text{ V}$ ,  $T_j = -40\text{ °C}$  to  $+150\text{ °C}$ ,

all voltages with respect to ground, direction of currents as shown in [Figure 7](#) (unless otherwise specified)

Pos.	Parameter	Symbol	Limit Values			Unit	Conditions
			Min.	Typ.	Max.		
<b>Output Undervoltage Reset Comparator Default Values</b>							
7.2.1	Output Undervoltage Reset Lower Switching Threshold	$V_{RT,lo}$	4.6	4.7	4.8	V	$V_I = 0\text{ V}$ $V_Q$ decreasing
7.2.2	Output Undervoltage Reset Upper Switching Threshold	$V_{RT,hi}$	4.7	4.8	4.9	V	$V_I$ within operating range $V_Q$ increasing
7.2.3	Output Undervoltage Reset Switching Hysteresis	$V_{RT,hy}$	50	100	–	mV	$V_I$ within operating range
7.2.4	Output Undervoltage Reset Headroom	$V_{RH}$	250	300	–	mV	Calculated Value: $V_Q - V_{RT,lo}$ $V_I$ within operating range $I_Q = 50\text{ mA}$
<b>Reset Output RO</b>							
7.2.5	Reset Output Low Voltage	$V_{RO,low}$	–	0.2	0.8	V	$V_I = 0\text{ V}$ $1\text{ V} \leq V_Q < V_{RT,low}$ ; $I_{RO} = 0.3\text{ mA}$
7.2.6	Reset Output Sink Current Capability	$I_{RO,max}$	0.3	–	–	mA	$V_I = 0\text{ V}$ ; $1\text{ V} \leq V_Q < V_{RT,low}$ ; $V_{RO} = 5\text{ V}$
7.2.7	Reset Output External Pull-up Resistor to $V_Q$	$R_{RO}$	3.0	–	–	k $\Omega$	$1\text{ V} \leq V_Q < V_{RT}$ ; $V_{RO} \leq 0.4\text{ V}^{1)}$
7.2.8	Reset Output Leakage Current	$I_{RO,leak}$	–	5	10	$\mu\text{A}$	$V_{RO} = 5\text{ V}$
<b>Reset Delay Timing</b>							
7.2.9	Delay Pin Output Voltage	$V_D$	–	–	5	V	–
7.2.10	Upper Delay Switching Threshold	$V_{DST,hi}$	–	1.1	–	V	–
7.2.11	Lower Delay Switching Threshold	$V_{DST,lo}$	–	0.3	–	V	–
7.2.12	Delay Capacitor Charge Current	$I_{D,ch}$	–	3.5	–	$\mu\text{A}$	$V_D = 1\text{ V}$
7.2.13	Delay Capacitor Reset Discharge Current	$I_{DR,dSCH}$	–	70	–	mA	$V_D = 1\text{ V}$
7.2.14	Undervoltage Reset Delay Time	$t_{d,100nF}$	16	23	30	ms	Calculated value; $C_D = 100\text{ nF}^{2)}$ $C_D$ discharged to $V_{DST,lo}$

**Electrical Characteristics: Reset Function (cont'd)**

$V_I = 13.5\text{ V}$ ,  $T_j = -40\text{ °C}$  to  $+150\text{ °C}$ ,

all voltages with respect to ground, direction of currents as shown in **Figure 7** (unless otherwise specified)

Pos.	Parameter	Symbol	Limit Values			Unit	Conditions
			Min.	Typ.	Max.		
7.2.15	Power-on Reset Delay Time	$t_{d,PWR-ON,100nF}$	23	33	43	ms	Calculated value; $C_D = 100\text{ nF}^{2)}$ $C_D$ discharged to 0 V
7.2.16	Internal Reset Reaction Time	$t_{rr,int}$	–	10	15	$\mu\text{s}$	$C_D = 0\text{ nF}$
7.2.17	Delay Capacitor Discharge Time	$t_{rr,d}$	–	1	2	$\mu\text{s}$	$C_D = 100\text{ nF}$
7.2.18	Total Reset Reaction Time	$t_{rr,total}$	–	11	17	$\mu\text{s}$	Calculated Value: $t_{rr,total} = t_{rr,d} + t_{rr,int}$ $C_D = 100\text{ nF}^{2)}$

1) Parameter not subject of production test.

2) For programming a different delay and reset reaction time, see **Chapter 7.1** for calculation.

**7.3 Typical Performance Characteristics Reset Function**

**Undervoltage Reset Switching Thresholds**

$V_{RO,lo}$ ,  $V_{RO,hi}$  versus  $T_j$

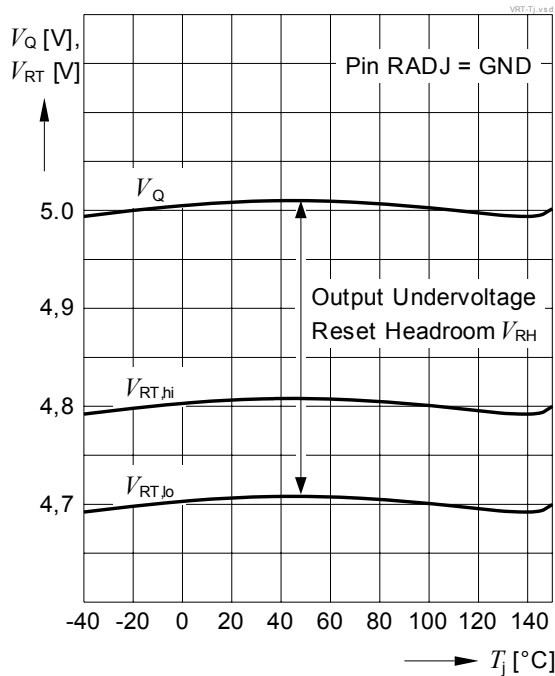

**Reset Delay Time  $t_d$ ,  $t_{d,PWR-ON}$  versus**

**Delay Capacitor  $C_D$**

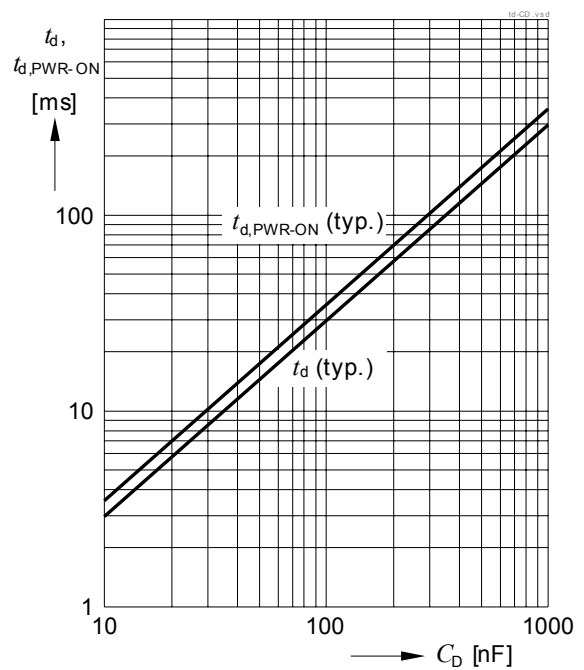

## 8 Package Outlines

### 8.1 PG-TO252-5 Package

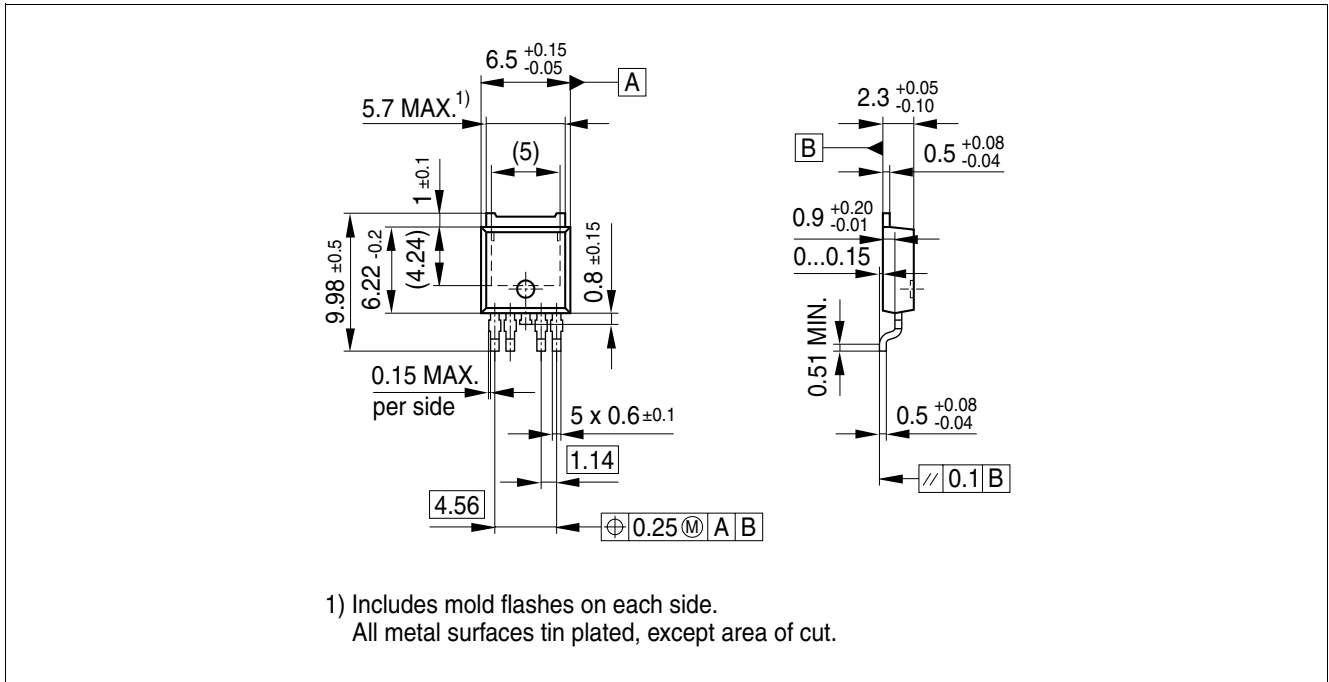

Figure 9 Package Outline PG-TO252-5

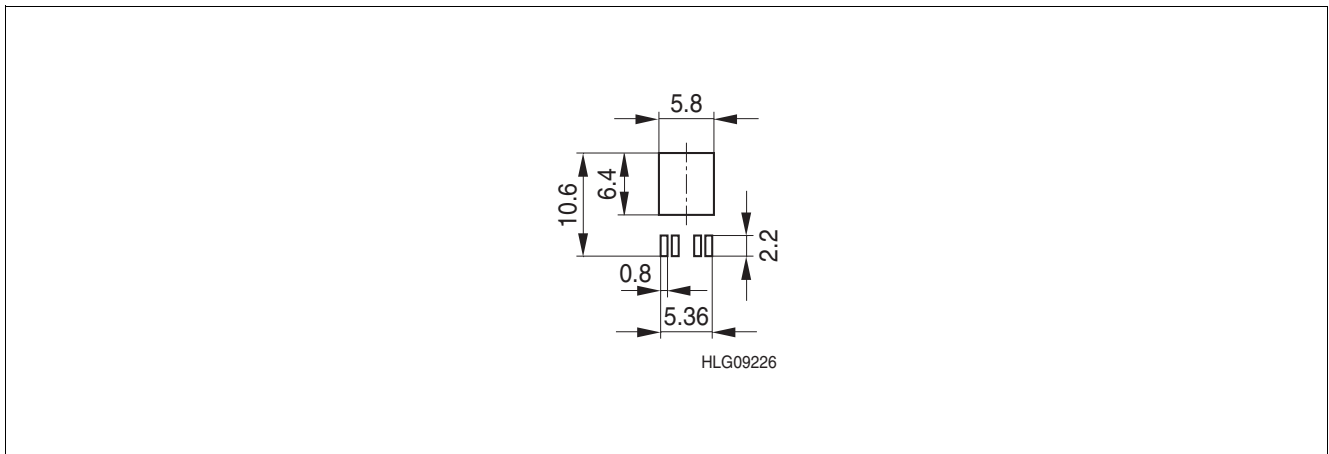

Figure 10 Footprint PG-TO252-5, Reflow Soldering Type

#### Green Product (RoHS compliant)

To meet the world-wide customer requirements for environmentally friendly products and to be compliant with government regulations the device is available as a green product. Green products are RoHS-Compliant (i.e. Pb-free finish on leads and suitable for Pb-free soldering according to IPC/JEDEC J-STD-020).

8.2 PG-TO263-5 Package

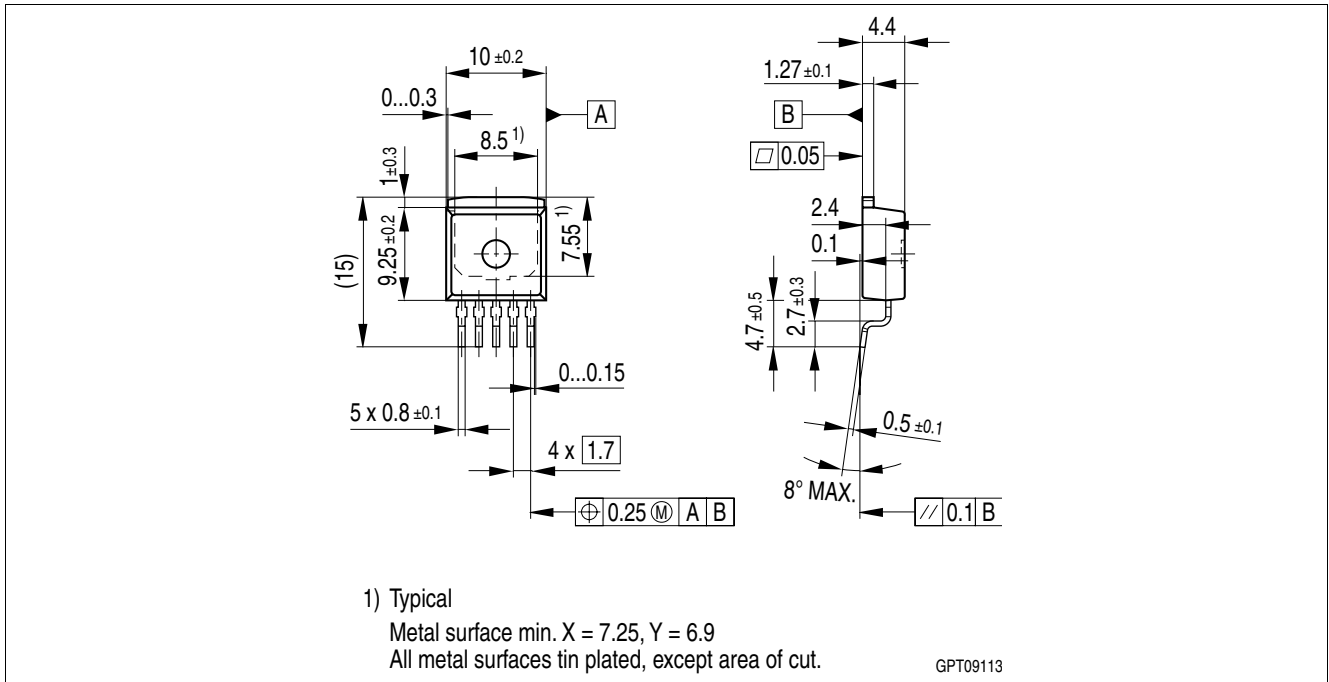

Figure 11 Package Outline PG-TO263-5

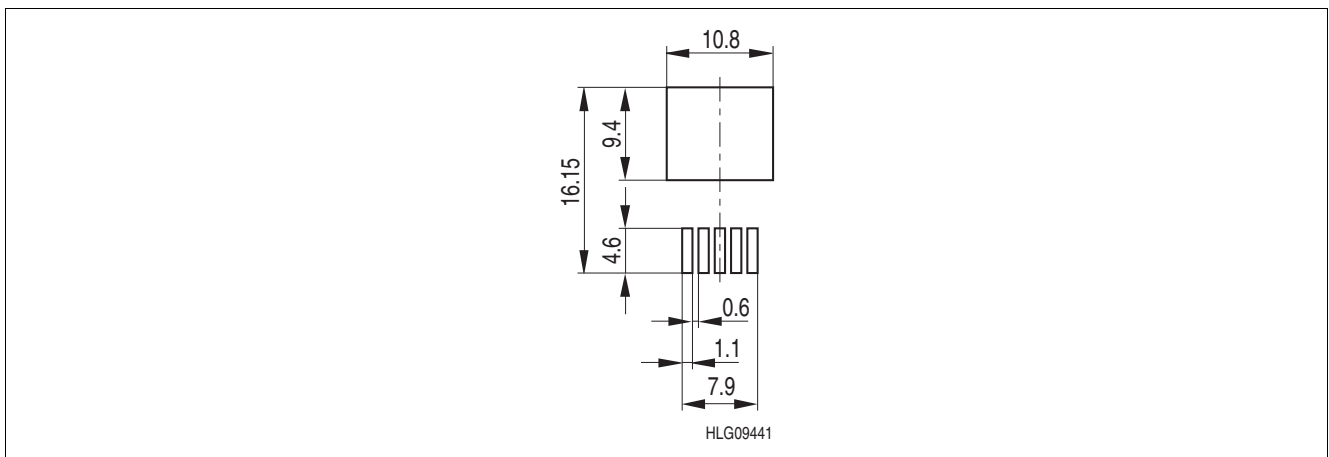

Figure 12 Footprint PG-TO263-5, Reflow Soldering Type

Green Product (RoHS compliant)

To meet the world-wide customer requirements for environmentally friendly products and to be compliant with government regulations the device is available as a green product. Green products are RoHS-Compliant (i.e Pb-free finish on leads and suitable for Pb-free soldering according to IPC/JEDEC J-STD-020).

For further information on packages, please visit our website:  
<http://www.infineon.com/packages>.

Dimensions in mm

## 9 Revision History

Revision	Date	Changes
1.0	2009-09-30	Final Data Sheet



**Edition 2008-09-30**

**Published by  
Infineon Technologies AG  
81726 Munich, Germany**

**© 2008 Infineon Technologies AG  
All Rights Reserved.**

### **Legal Disclaimer**

The information given in this document shall in no event be regarded as a guarantee of conditions or characteristics. With respect to any examples or hints given herein, any typical values stated herein and/or any information regarding the application of the device, Infineon Technologies hereby disclaims any and all warranties and liabilities of any kind, including without limitation, warranties of non-infringement of intellectual property rights of any third party.

### **Information**

For further information on technology, delivery terms and conditions and prices, please contact the nearest Infineon Technologies Office ([www.infineon.com](http://www.infineon.com)).

### **Warnings**

Due to technical requirements, components may contain dangerous substances. For information on the types in question, please contact the nearest Infineon Technologies Office.

Infineon Technologies components may be used in life-support devices or systems only with the express written approval of Infineon Technologies, if a failure of such components can reasonably be expected to cause the failure of that life-support device or system or to affect the safety or effectiveness of that device or system. Life support devices or systems are intended to be implanted in the human body or to support and/or maintain and sustain and/or protect human life. If they fail, it is reasonable to assume that the health of the user or other persons may be endangered.