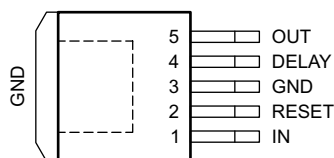
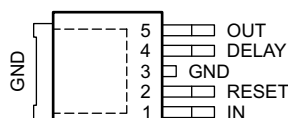
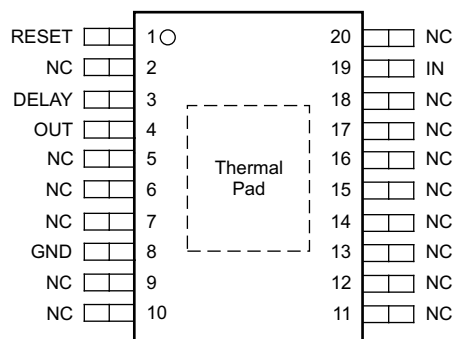

## 5-V LOW-DROPOUT VOLTAGE REGULATOR

 Check for Samples: [TLE4275-Q1](#)

### FEATURES

- Qualified for Automotive Applications
- Output Voltage  $5\text{ V} \pm 2\%$
- Very Low Current Consumption
- Power-On and Undervoltage Reset
- Reset Low-Level Output Voltage  $< 1\text{ V}$
- Very Low Dropout Voltage
- Short-Circuit Proof
- Reverse-Polarity Proof

**KTT (TO-263-5) Package  
(Top View)**

**KVU (TO-252-5) Package  
(Top View)**

**PWP (HTSSOP) Package  
(Top View)**

### DESCRIPTION

The TLE4275 is a monolithic integrated low-dropout voltage regulator offered in a 5-pin TO package. The device regulates an input voltage up to 45 V to  $V_{OUT} = 5\text{ V}$  (typ). The device can drive loads up to 450 mA and is short-circuit proof. At overtemperature, the incorporated temperature protection turns off the TLE4275. The device generates a reset signal for an output voltage,  $V_{OUT,rt}$ , of 4.65 V (typ). By the use of an external delay capacitor, one can program the reset delay time.

The input capacitor,  $C_{IN}$ , compensates for line fluctuation. Using a resistor of approximately  $1\ \Omega$  in series with  $C_{IN}$  dampens the oscillation of input inductance and input capacitance. The output capacitor,  $C_{OUT}$ , stabilizes the regulation circuit. The specification for stability is at  $C_{OUT} \geq 22\ \mu\text{F}$  and  $\text{ESR} \leq 5\ \Omega$ , within the operating temperature range. Stability for electrolytic capacitors specifically is at  $C_{OUT} \geq 68\ \mu\text{F}$  within the operating temperature range. See the application report on low-temperature stability, [SLVA501](#), for further details.

The control amplifier compares a reference voltage to a voltage that is proportional to the output voltage and drives the base of the series transistor via a buffer. Saturation control as a function of the load current prevents any oversaturation of the power element. The device also incorporates a number of internal circuits for protection against:

- Overload
- Overtemperature
- Reverse polarity

### ORDERING INFORMATION

For the most current package and ordering information, see the Package Option Addendum at the end of this document, or see the TI Web site at [www.ti.com](http://www.ti.com).

Package drawings, thermal data, and symbolization are available at [www.ti.com/packaging](http://www.ti.com/packaging).



Please be aware that an important notice concerning availability, standard warranty, and use in critical applications of Texas Instruments semiconductor products and disclaimers thereto appears at the end of this data sheet.

**PIN FUNCTIONS**

NAME	NO.			DESCRIPTION
	KTT	KVU	PWP	
DELAY	4	4	3	Reset delay. Connect to ground with a capacitor to set delay time.
GND	3	3	8	Ground. Internally connected to heatsink
IN	1	1	19	Input. Connect to ground as close to device as possible, through a ceramic capacitor.
NC	–	–	2, 5–7, 9–18, 20	Not connected
OUT	5	5	4	Output. Connect to ground with $\geq 22\text{-}\mu\text{F}$ capacitor, $\text{ESR} < 5\ \Omega$ at 10 kHz.
RESET	2	2	1	Reset output. Open-collector output

**FUNCTIONAL BLOCK DIAGRAM**

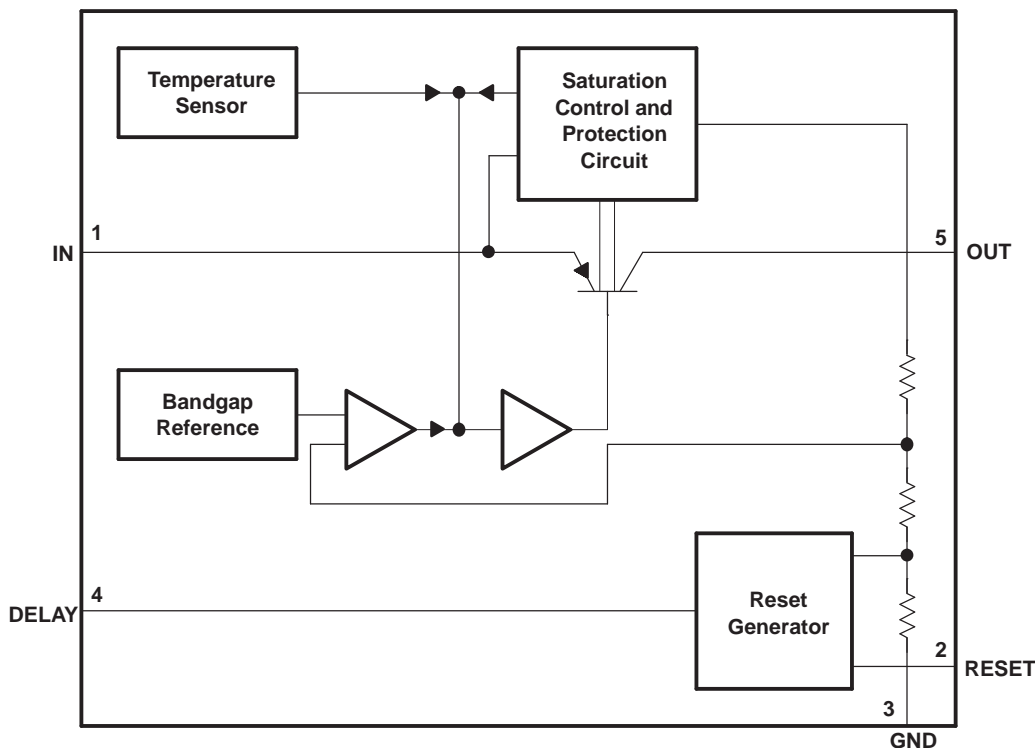

## ABSOLUTE MAXIMUM RATINGS<sup>(1)</sup>

over operating free-air temperature range (unless otherwise noted)

		MIN	MAX	UNIT	
V <sub>I</sub>	Input voltage range <sup>(2)</sup>	IN	-42	45	V
		DELAY	-0.3	7	
V <sub>O</sub>	Output voltage range	OUT	-1	16	V
		RESET	-0.3	25	
I <sub>I</sub>	Input current	DELAY		±2	mA
I <sub>O</sub>	Output current	RESET		±5	mA
T <sub>J</sub>	Operating junction temperature range		-40	150	°C
T <sub>stg</sub>	Storage temperature range		-65	150	°C
ESD	Electrostatic discharge rating	Human-body model (HBM) <sup>(3)</sup>		6000	V
		Machine model (MM) <sup>(4)</sup>		400	

- (1) Stresses beyond those listed under *Absolute Maximum Ratings* may cause permanent damage to the device. These are stress ratings only, and functional operation of the device at these or any other conditions beyond those indicated under *Recommended Operating Conditions* is not implied. Exposure to absolute-maximum-rated conditions for extended periods may affect device reliability.
- (2) All voltage values are with respect to the network ground terminal.
- (3) HBM ESD rating tested per JESD22-A114.
- (4) MM ESD rating tested per JESD22-A115.

## RECOMMENDED OPERATING CONDITIONS

over operating free-air temperature range (unless otherwise noted)

		MIN	MAX	UNIT
V <sub>I</sub>	Input voltage	5.5	42	V
T <sub>J</sub>	Junction temperature	-40	150	°C

## THERMAL INFORMATION

THERMAL METRIC <sup>(1)</sup>	TLE4275-Q1			UNIT	
	KTT	KVU	PWP		
	5 PINS	5 PINS	20 PINS		
θ <sub>JA</sub>	Junction-to-ambient thermal resistance <sup>(2)</sup>	28.8	40.3	39.3	°C/W
θ <sub>JCtop</sub>	Junction-to-case (top) thermal resistance <sup>(3)</sup>	43.1	31.8	22.7	°C/W
θ <sub>JB</sub>	Junction-to-board thermal resistance <sup>(4)</sup>	0.8	17.2	19.1	°C/W
ψ <sub>JT</sub>	Junction-to-top characterization parameter <sup>(5)</sup>	3.7	2.8	0.6	°C/W
ψ <sub>JB</sub>	Junction-to-board characterization parameter <sup>(6)</sup>	0.7	17.1	18.9	°C/W
θ <sub>JCbot</sub>	Junction-to-case (bottom) thermal resistance <sup>(7)</sup>	0.2	0.7	1.5	°C/W

- (1) For more information about traditional and new thermal metrics, see the *IC Package Thermal Metrics* application report, [SPRA953](#).
- (2) The junction-to-ambient thermal resistance under natural convection is obtained in a simulation on a JEDEC-standard, high-K board, as specified in JESD51-7, in an environment described in JESD51-2a.
- (3) The junction-to-case (top) thermal resistance is obtained by simulating a cold plate test on the package top. No specific JEDEC-standard test exists, but a close description can be found in the ANSI SEMI standard G30-88.
- (4) The junction-to-board thermal resistance is obtained by simulating in an environment with a ring cold plate fixture to control the PCB temperature, as described in JESD51-8.
- (5) The junction-to-top characterization parameter, ψ<sub>JT</sub>, estimates the junction temperature of a device in a real system and is extracted from the simulation data for obtaining θ<sub>JA</sub>, using a procedure described in JESD51-2a (sections 6 and 7).
- (6) The junction-to-board characterization parameter, ψ<sub>JB</sub>, estimates the junction temperature of a device in a real system and is extracted from the simulation data for obtaining θ<sub>JA</sub>, using a procedure described in JESD51-2a (sections 6 and 7).
- (7) The junction-to-case (bottom) thermal resistance is obtained by simulating a cold plate test on the exposed (power) pad. No specific JEDEC standard test exists, but a close description can be found in the ANSI SEMI standard G30-88.

## ELECTRICAL CHARACTERISTICS

over recommended operating free-air temperature range,  $V_I = 13.5\text{ V}$ ,  $T_J = -40^\circ\text{C}$  to  $150^\circ\text{C}$  (unless otherwise noted) (see [Figure 1](#))

PARAMETER		TEST CONDITIONS	MIN	TYP	MAX	UNIT
$V_O$	Output voltage	$I_O = 5\text{ mA}$ to $400\text{ mA}$ , $V_I = 6\text{ V}$ to $28\text{ V}$	4.9	5	5.1	V
		$I_O = 5\text{ mA}$ to $200\text{ mA}$ , $V_I = 6\text{ V}$ to $40\text{ V}$	4.9	5	5.1	
$I_O$	Output current limit		450	700	950	mA
$I_q$	Current consumption $I_q = I_I - I_O$	$I_O = 1\text{ mA}$	$T_J = 25^\circ\text{C}$	150	200	$\mu\text{A}$
			$T_J \leq 85^\circ\text{C}$	150	220	
		$I_O = 250\text{ mA}$		5	10	mA
		$I_O = 400\text{ mA}$		12	22	
$V_{DO}$	Dropout voltage <sup>(1)</sup>	$I_O = 300\text{ mA}$ , $V_{do} = V_I - V_O$		250	500	mV
	Load regulation	$I_O = 5\text{ mA}$ to $400\text{ mA}$		15	30	mV
	Line regulation	$\Delta V_I = 8\text{ V}$ to $32\text{ V}$ , $I_O = 5\text{ mA}$	-15	5	15	mV
PSRR	Power-supply ripple rejection	$f_r = 100\text{ Hz}$ , $V_r = 0.5\text{ V}_{pp}$		60		dB
$\frac{\Delta V_O}{\Delta T}$	Temperature output-voltage drift			0.5		mV/K
$V_{O,rt}$	RESET switching threshold		4.5	4.65	4.8	V
$V_{ROL}$	RESET output low voltage	$R_{ext} \geq 5\text{ k}\Omega$ , $V_O > 1\text{ V}$		0.2	0.4	V
$I_{ROH}$	RESET output leakage current	$V_{ROH} = 5\text{ V}$		0	10	$\mu\text{A}$
$I_{D,c}$	RESET charging current	$V_D = 1\text{ V}$	3	5.5	9	$\mu\text{A}$
$V_{DU}$	RESET upper timing threshold		1.5	1.8	2.2	V
$V_{DRL}$	RESET lower timing threshold		0.2	0.4	0.7	V

(1) Measured when the output voltage  $V_O$  has dropped 100 mV from the nominal value obtained at  $V_I = 13.5\text{ V}$

## SWITCHING CHARACTERISTICS

over operating free-air temperature range (unless otherwise noted) (see [Figure 2](#))

PARAMETER		TEST CONDITIONS	MIN	TYP	MAX	UNIT
$t_{rd}$	RESET delay time	$C_D = 47\text{ nF}$	10	16	22	ms
$t_{rr}$	RESET reaction time	$C_D = 47\text{ nF}$		0.5	2	$\mu\text{s}$

TYPICAL CHARACTERISTICS

At  $T_A = 25^\circ\text{C}$

OUTPUT VOLTAGE  
versus  
JUNCTION TEMPERATURE

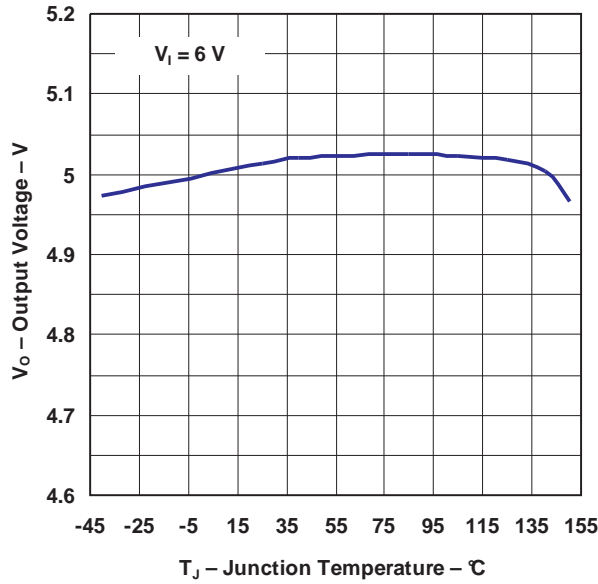

OUTPUT VOLTAGE  
versus  
JUNCTION TEMPERATURE

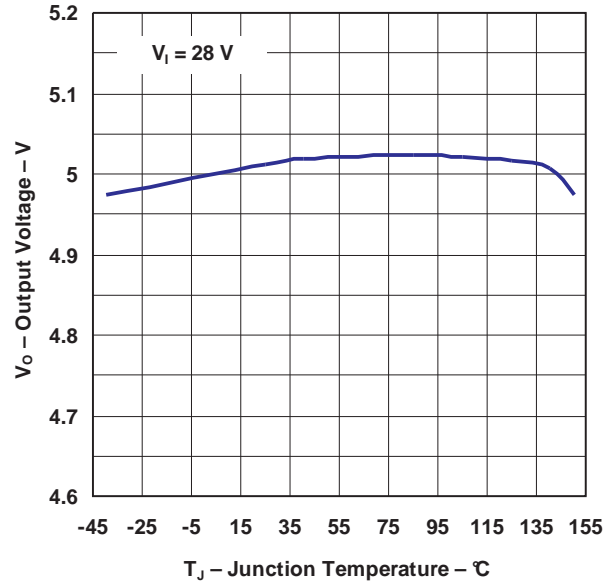

OUTPUT VOLTAGE  
versus  
INPUT VOLTAGE

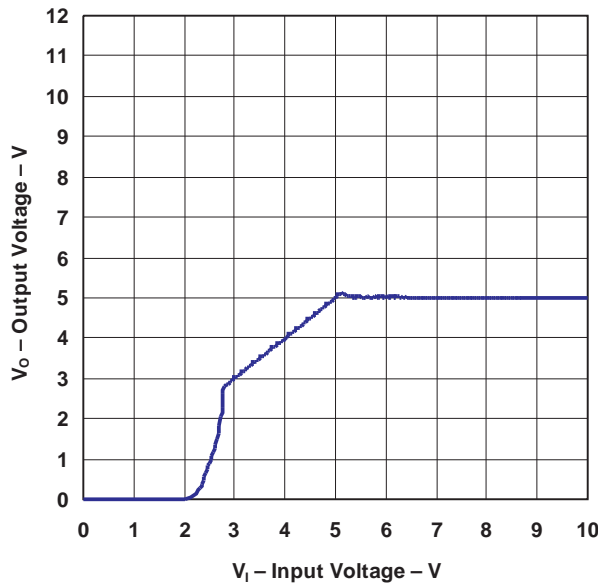

OUTPUT CURRENT  
versus  
JUNCTION TEMPERATURE

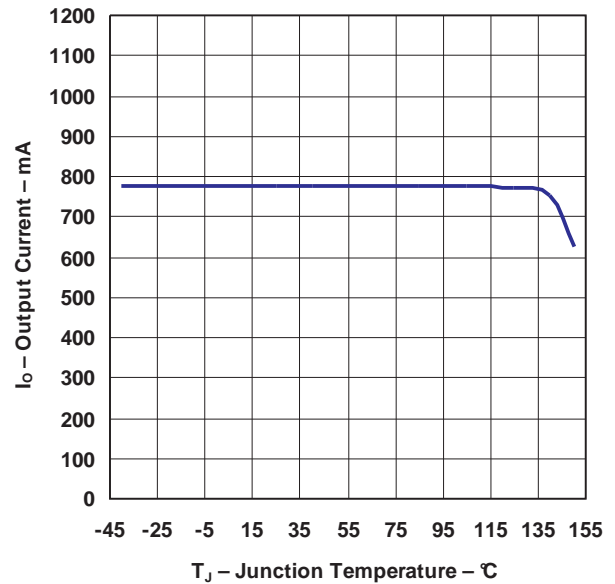

**TYPICAL CHARACTERISTICS (continued)**

At  $T_A = 25^\circ\text{C}$

**CURRENT CONSUMPTION  
versus  
OUTPUT CURRENT**

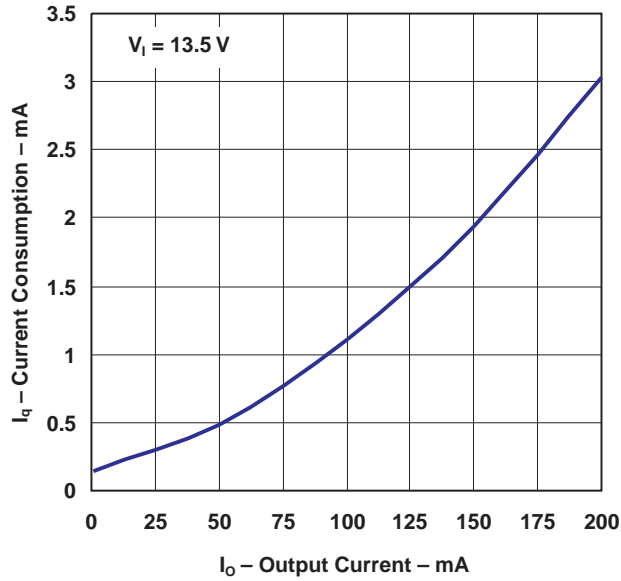

**CURRENT CONSUMPTION  
versus  
OUTPUT CURRENT**

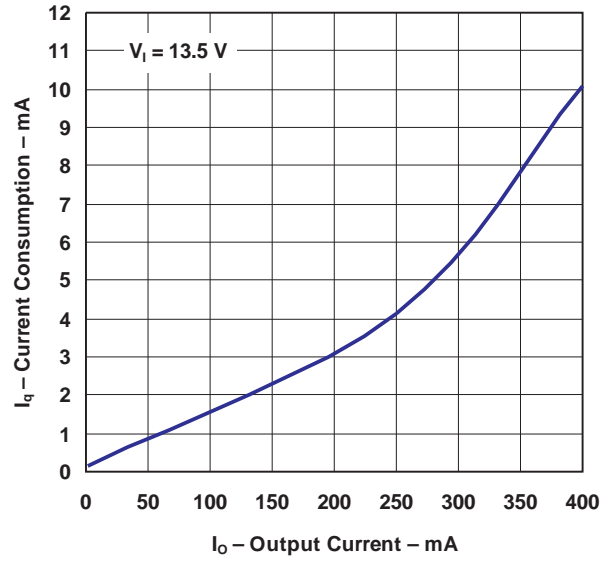

**DROPOUT VOLTAGE  
versus  
OUTPUT CURRENT**

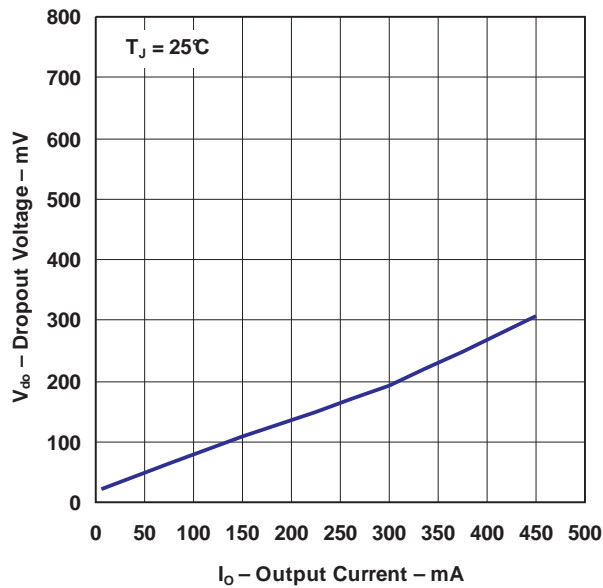

**CHARGE CURRENT  
versus  
JUNCTION TEMPERATURE**

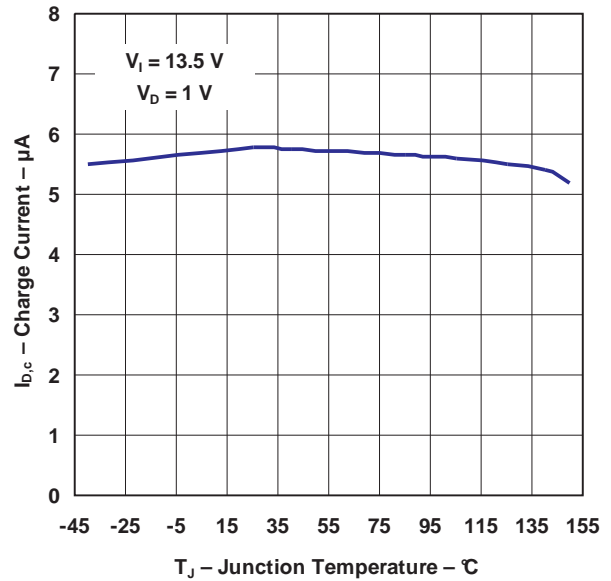

TYPICAL CHARACTERISTICS (continued)

At  $T_A = 25^\circ\text{C}$

DELAY SWITCHING THRESHOLD  
versus  
JUNCTION TEMPERATURE

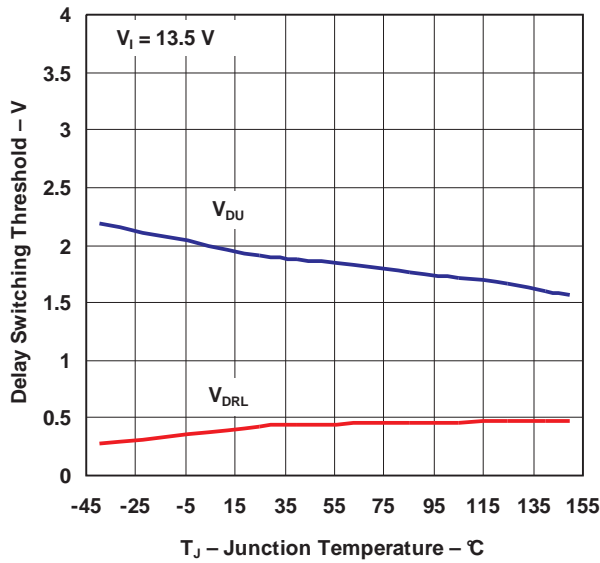

POWER-SUPPLY RIPPLE REJECTION  
versus  
FREQUENCY

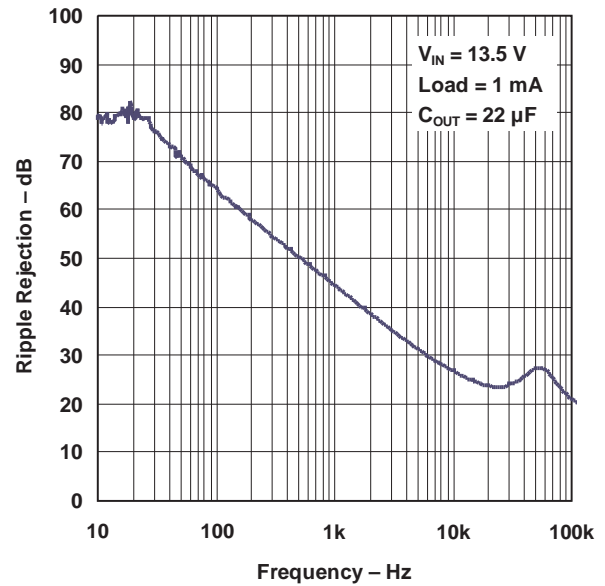

POWER-SUPPLY RIPPLE REJECTION  
versus  
FREQUENCY

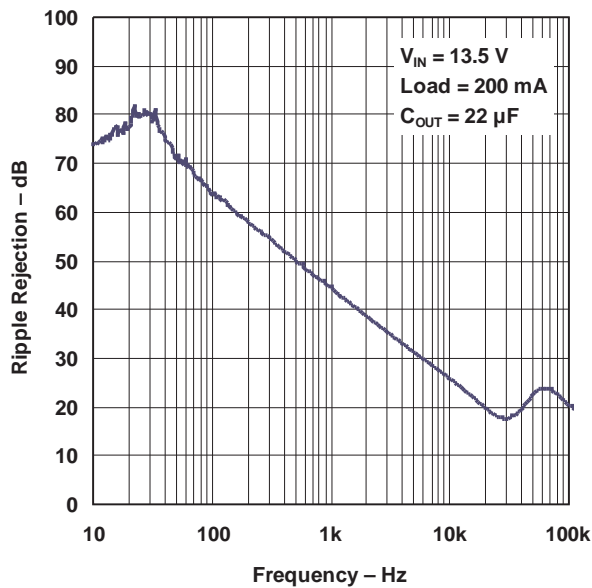

POWER-SUPPLY RIPPLE REJECTION  
versus  
FREQUENCY

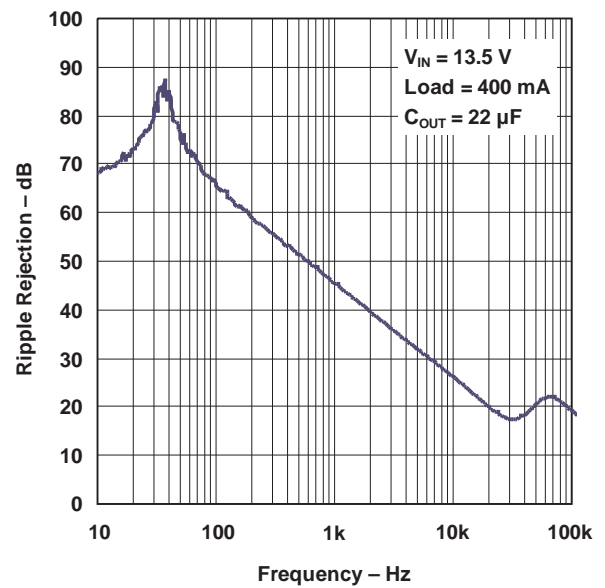

**TYPICAL CHARACTERISTICS (continued)**

At  $T_A = 25^\circ\text{C}$

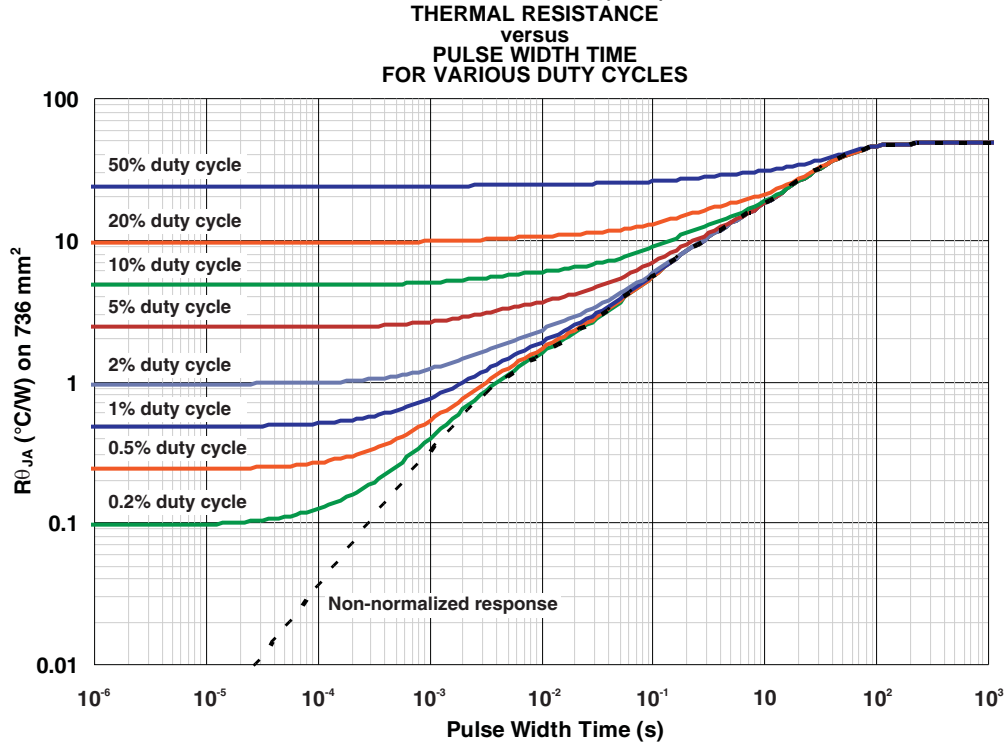
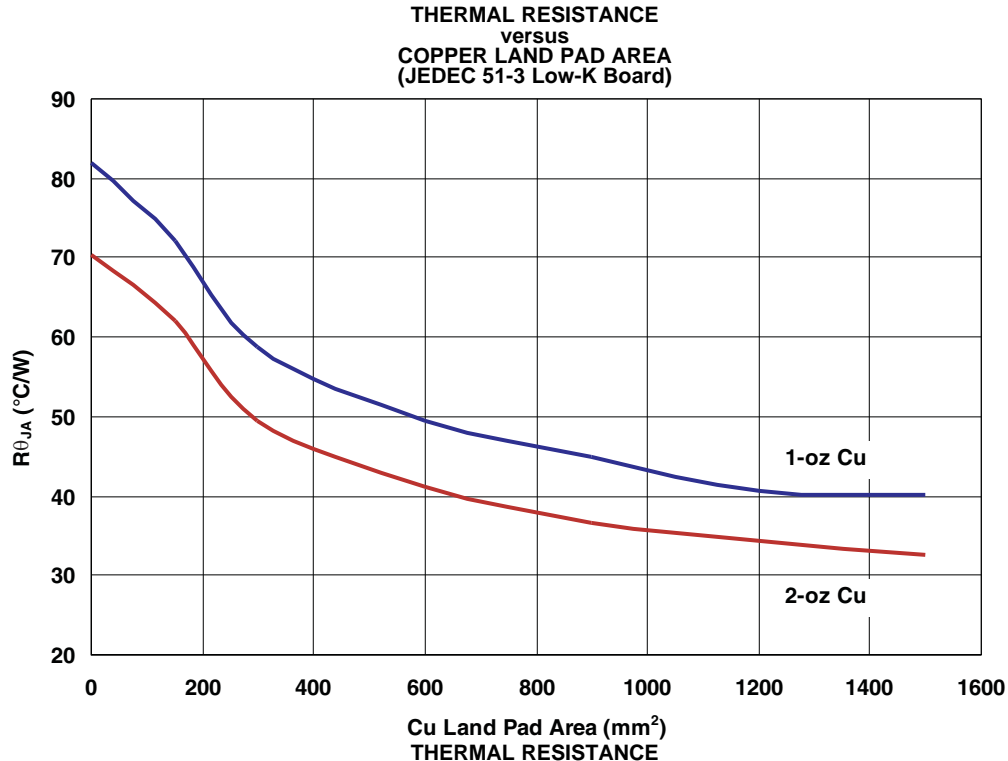



TYPICAL CHARACTERISTICS (continued)

At  $T_A = 25^\circ\text{C}$

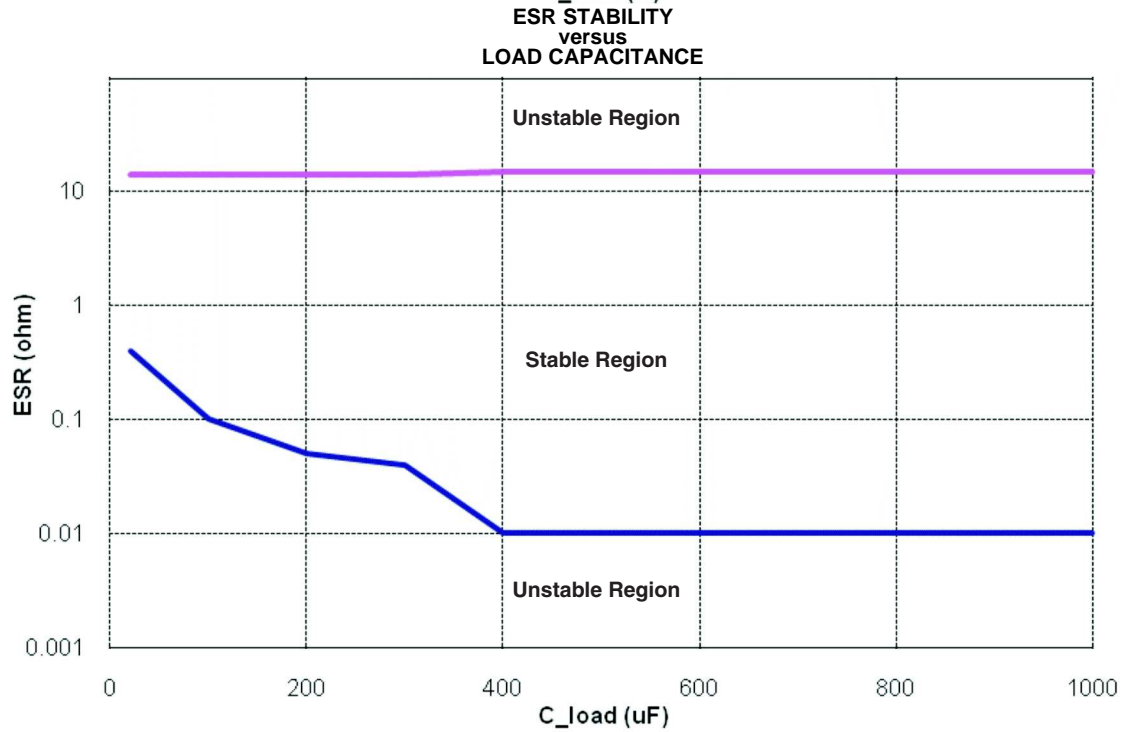
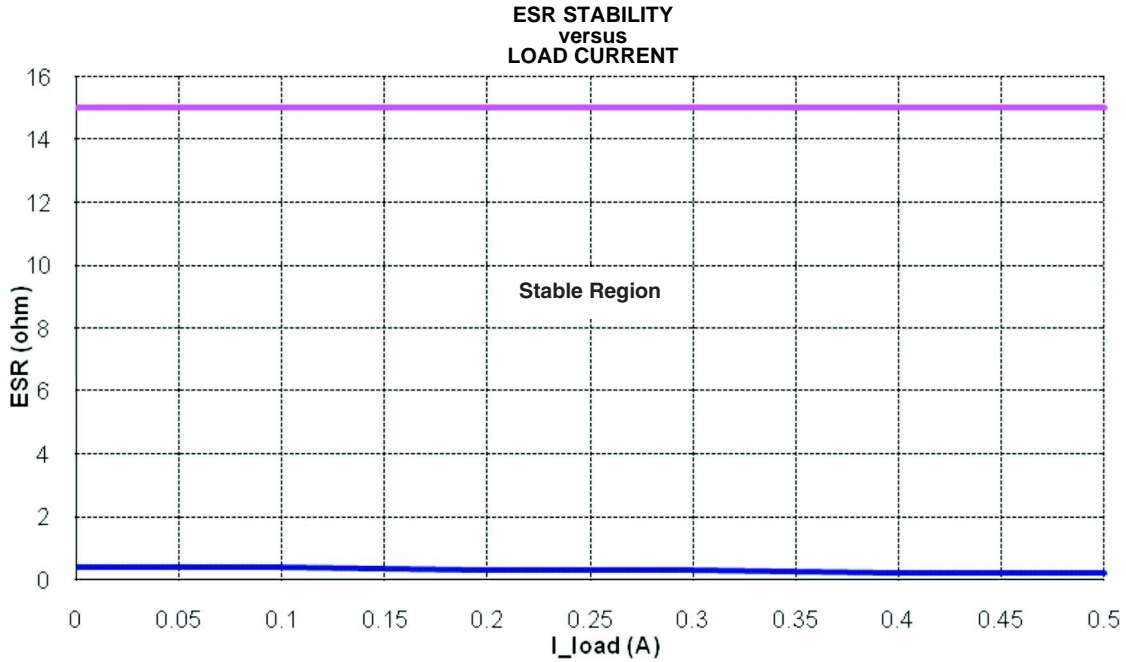

PARAMETER MEASUREMENT INFORMATION

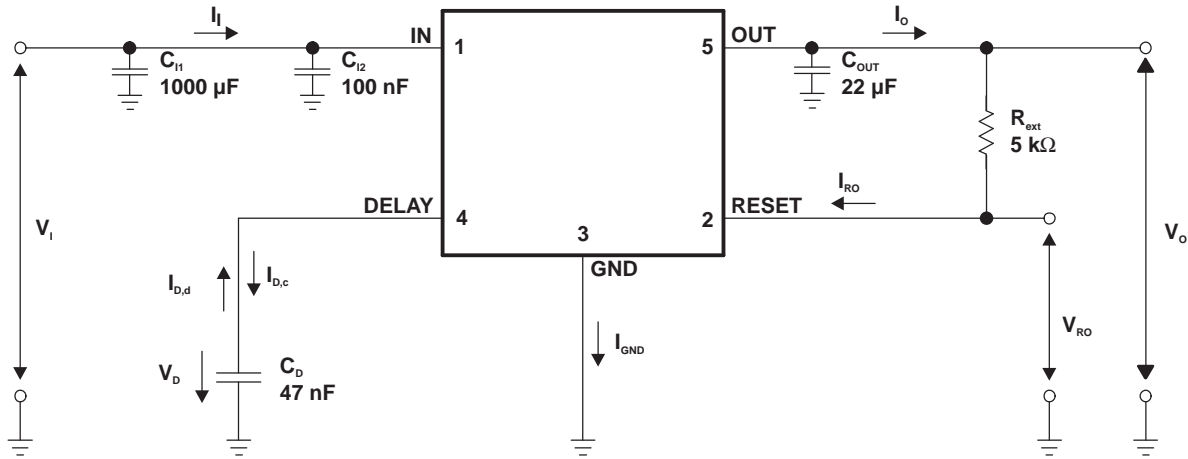

Figure 1. Test Circuit

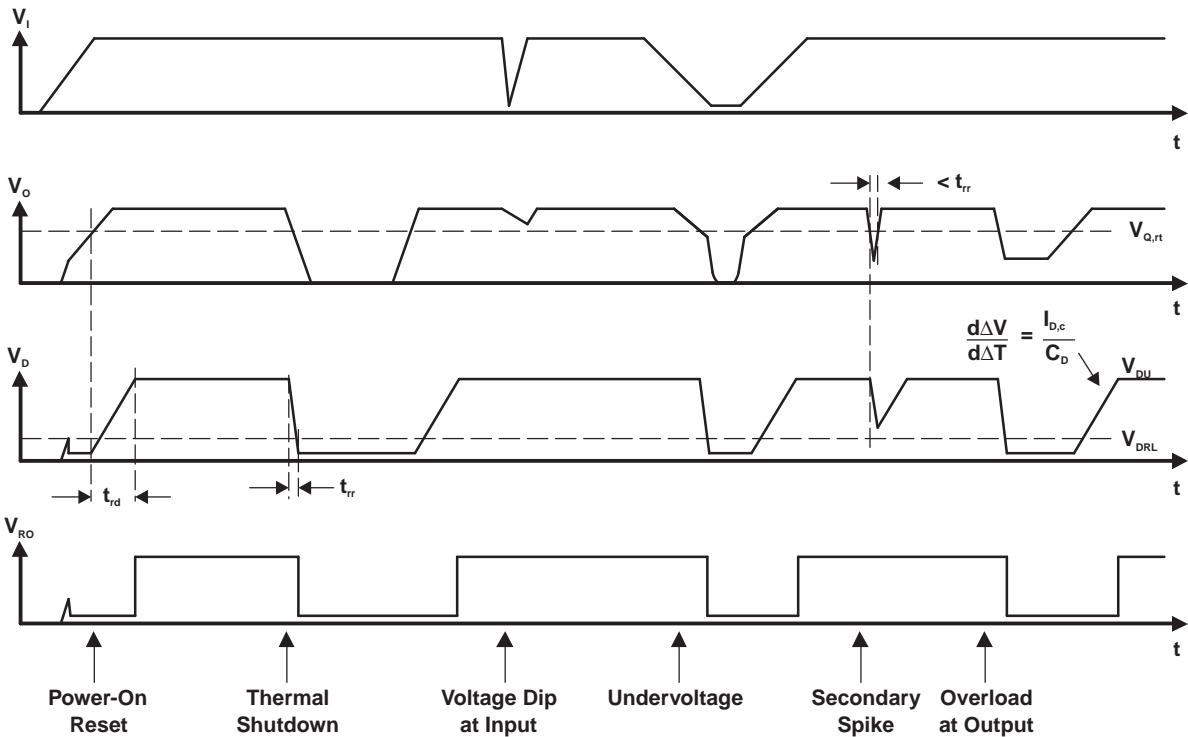

Figure 2. Reset Timing

## REVISION HISTORY

<b>Changes from Revision G (January 2013) to Revision H</b>	<b>Page</b>
• Deleted Ordering Information table .....	1
• Deleted row for $\theta_{JA}$ from Absolute Maximum Ratings table .....	3
• Added Thermal Information table .....	3
<b>Changes from Revision F (May 2011) to Revision G</b>	<b>Page</b>
• Added pin out image for PWP package. ....	1
• Deleted package column from ordering information table, added orderable part number for PWP package and changed top-side marking to preview. ....	1
• Updated pin functions table with PWP package pin information. ....	2

**PACKAGING INFORMATION**

Orderable Device	Status (1)	Package Type	Package Drawing	Pins	Package Qty	Eco Plan (2)	Lead/Ball Finish	MSL Peak Temp (3)	Op Temp (°C)	Device Marking (4/5)	Samples
TLE4275QKTTTRQ1	ACTIVE	DDPAK/ TO-263	KTT	5	500	Green (RoHS & no Sb/Br)	CU SN	Level-3-245C-168 HR	-40 to 125	TLE4275Q	<a href="#">Samples</a>
TLE4275QKVURQ1	ACTIVE	TO-252	KVU	5	2500	Green (RoHS & no Sb/Br)	CU SN	Level-3-260C-168 HR	-40 to 125	TLE4275Q	<a href="#">Samples</a>
TLE4275QPWPRQ1	ACTIVE	HTSSOP	PWP	20	2000	Green (RoHS & no Sb/Br)	CU NIPDAU	Level-3-260C-168 HR	-40 to 125	TLE4275Q	<a href="#">Samples</a>

(1) The marketing status values are defined as follows:

**ACTIVE:** Product device recommended for new designs.

**LIFEBUY:** TI has announced that the device will be discontinued, and a lifetime-buy period is in effect.

**NRND:** Not recommended for new designs. Device is in production to support existing customers, but TI does not recommend using this part in a new design.

**PREVIEW:** Device has been announced but is not in production. Samples may or may not be available.

**OBsolete:** TI has discontinued the production of the device.

(2) Eco Plan - The planned eco-friendly classification: Pb-Free (RoHS), Pb-Free (RoHS Exempt), or Green (RoHS & no Sb/Br) - please check <http://www.ti.com/productcontent> for the latest availability information and additional product content details.

**TBD:** The Pb-Free/Green conversion plan has not been defined.

**Pb-Free (RoHS):** TI's terms "Lead-Free" or "Pb-Free" mean semiconductor products that are compatible with the current RoHS requirements for all 6 substances, including the requirement that lead not exceed 0.1% by weight in homogeneous materials. Where designed to be soldered at high temperatures, TI Pb-Free products are suitable for use in specified lead-free processes.

**Pb-Free (RoHS Exempt):** This component has a RoHS exemption for either 1) lead-based flip-chip solder bumps used between the die and package, or 2) lead-based die adhesive used between the die and leadframe. The component is otherwise considered Pb-Free (RoHS compatible) as defined above.

**Green (RoHS & no Sb/Br):** TI defines "Green" to mean Pb-Free (RoHS compatible), and free of Bromine (Br) and Antimony (Sb) based flame retardants (Br or Sb do not exceed 0.1% by weight in homogeneous material)

(3) MSL, Peak Temp. -- The Moisture Sensitivity Level rating according to the JEDEC industry standard classifications, and peak solder temperature.

(4) There may be additional marking, which relates to the logo, the lot trace code information, or the environmental category on the device.

(5) Multiple Device Markings will be inside parentheses. Only one Device Marking contained in parentheses and separated by a "~" will appear on a device. If a line is indented then it is a continuation of the previous line and the two combined represent the entire Device Marking for that device.

**Important Information and Disclaimer:** The information provided on this page represents TI's knowledge and belief as of the date that it is provided. TI bases its knowledge and belief on information provided by third parties, and makes no representation or warranty as to the accuracy of such information. Efforts are underway to better integrate information from third parties. TI has taken and continues to take reasonable steps to provide representative and accurate information but may not have conducted destructive testing or chemical analysis on incoming materials and chemicals. TI and TI suppliers consider certain information to be proprietary, and thus CAS numbers and other limited information may not be available for release.

In no event shall TI's liability arising out of such information exceed the total purchase price of the TI part(s) at issue in this document sold by TI to Customer on an annual basis.

## TAPE AND REEL INFORMATION



### QUADRANT ASSIGNMENTS FOR PIN 1 ORIENTATION IN TAPE



\*All dimensions are nominal

Device	Package Type	Package Drawing	Pins	SPQ	Reel Diameter (mm)	Reel Width W1 (mm)	A0 (mm)	B0 (mm)	K0 (mm)	P1 (mm)	W (mm)	Pin1 Quadrant
TLE4275QKTTRQ1	DDPAK/ TO-263	KTT	5	500	330.0	24.4	10.6	15.8	4.9	16.0	24.0	Q2
TLE4275QKVURQ1	TO-252	KVU	5	2500	330.0	16.4	6.9	10.5	2.7	8.0	16.0	Q2
TLE4275QPWPRQ1	HTSSOP	PWP	20	2000	330.0	16.4	6.95	7.1	1.6	8.0	16.0	Q1

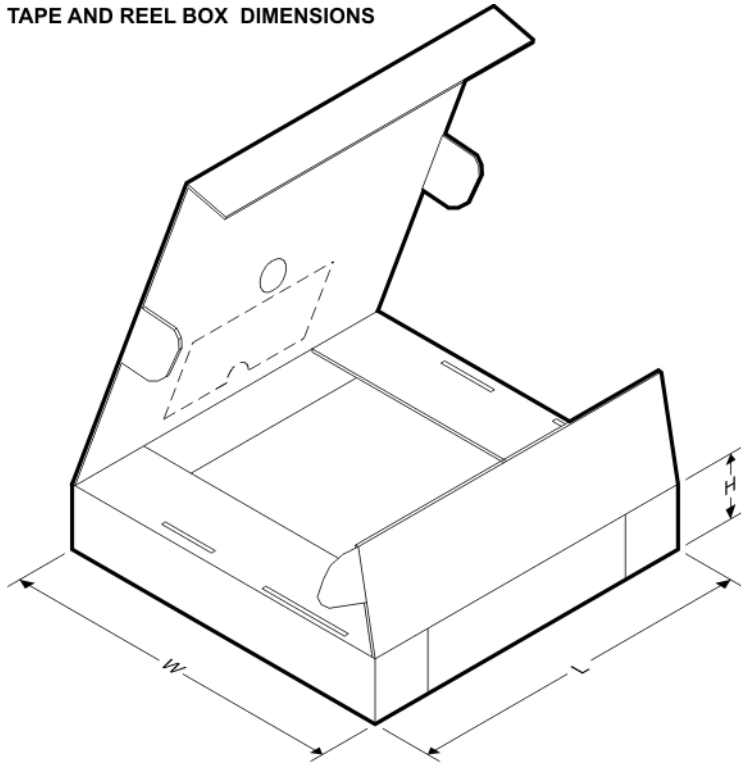
**TAPE AND REEL BOX DIMENSIONS**

\*All dimensions are nominal

Device	Package Type	Package Drawing	Pins	SPQ	Length (mm)	Width (mm)	Height (mm)
TLE4275QKTTRQ1	DDPAK/TO-263	KTT	5	500	340.0	340.0	38.0
TLE4275QKVURQ1	TO-252	KVU	5	2500	340.0	340.0	38.0
TLE4275QPWPRQ1	HTSSOP	PWP	20	2000	367.0	367.0	38.0

# MECHANICAL DATA

PWP (R-PDSO-G20)

PowerPAD™ PLASTIC SMALL OUTLINE

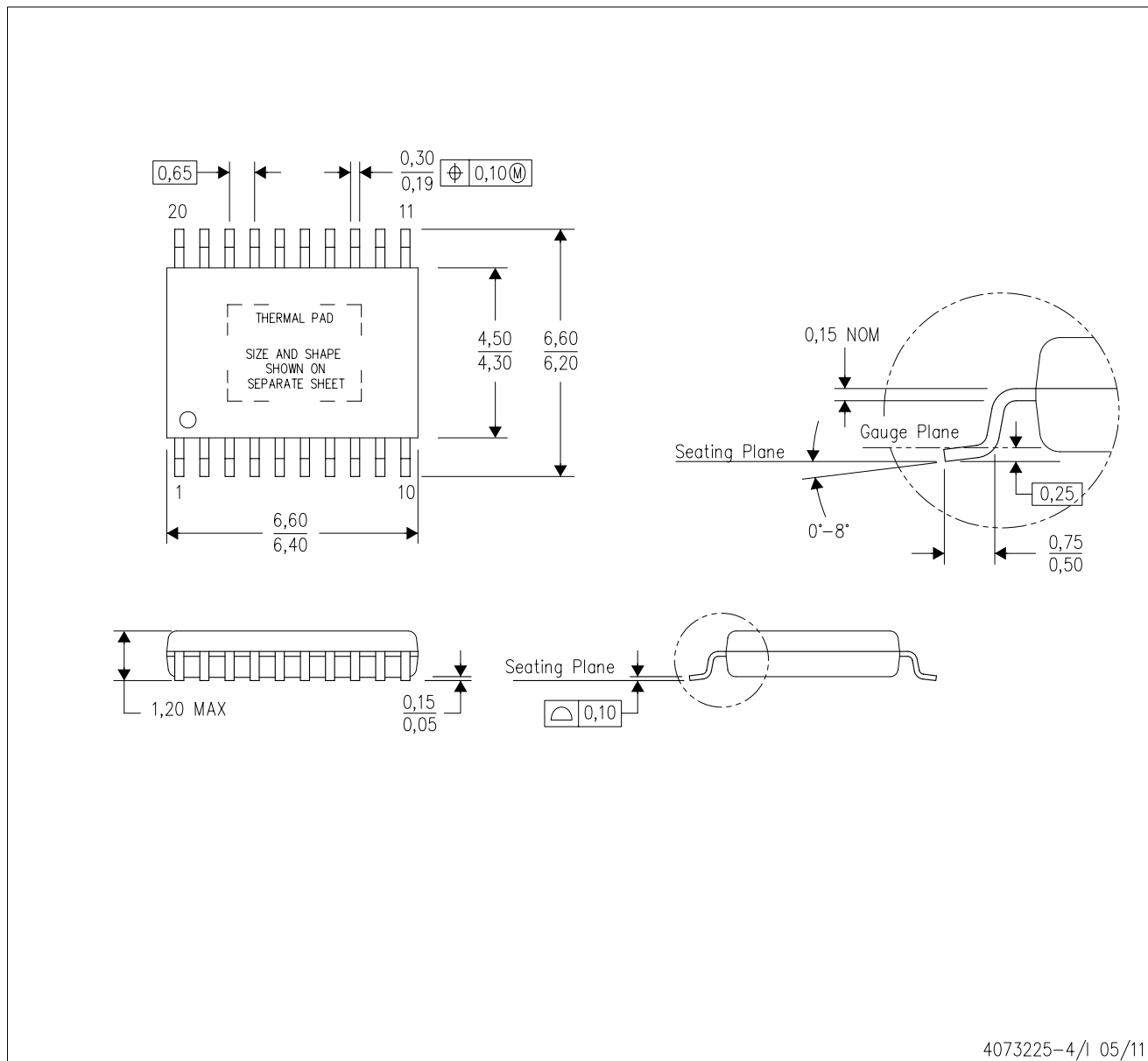

4073225-4/1 05/11

- NOTES:
- All linear dimensions are in millimeters.
  - This drawing is subject to change without notice.
  - Body dimensions do not include mold flash or protrusions. Mold flash and protrusion shall not exceed 0.15 per side.
  - This package is designed to be soldered to a thermal pad on the board. Refer to Technical Brief, PowerPad Thermally Enhanced Package, Texas Instruments Literature No. SLMA002 for information regarding recommended board layout. This document is available at [www.ti.com](http://www.ti.com) <<http://www.ti.com>>.
  - See the additional figure in the Product Data Sheet for details regarding the exposed thermal pad features and dimensions.
  - Falls within JEDEC MO-153

PowerPAD is a trademark of Texas Instruments.



## THERMAL PAD MECHANICAL DATA

### PWP (R-PDSO-G20) PowerPAD™ SMALL PLASTIC OUTLINE

#### THERMAL INFORMATION

This PowerPAD™ package incorporates an exposed thermal pad that is designed to be attached to a printed circuit board (PCB). The thermal pad must be soldered directly to the PCB. After soldering, the PCB can be used as a heatsink. In addition, through the use of thermal vias, the thermal pad can be attached directly to the appropriate copper plane shown in the electrical schematic for the device, or alternatively, can be attached to a special heatsink structure designed into the PCB. This design optimizes the heat transfer from the integrated circuit (IC).

For additional information on the PowerPAD package and how to take advantage of its heat dissipating abilities, refer to Technical Brief, PowerPAD Thermally Enhanced Package, Texas Instruments Literature No. SLMA002 and Application Brief, PowerPAD Made Easy, Texas Instruments Literature No. SLMA004. Both documents are available at [www.ti.com](http://www.ti.com).

The exposed thermal pad dimensions for this package are shown in the following illustration.

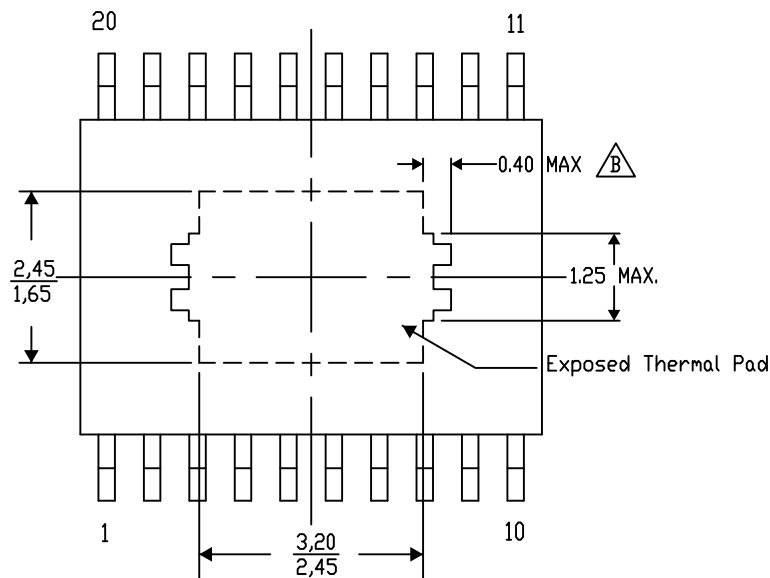

4206332-18/AF 06/13

NOTE: A. All linear dimensions are in millimeters

 Exposed tie strap features may not be present.

PowerPAD is a trademark of Texas Instruments

KTT (R-PSFM-G5)

PLASTIC FLANGE-MOUNT PACKAGE

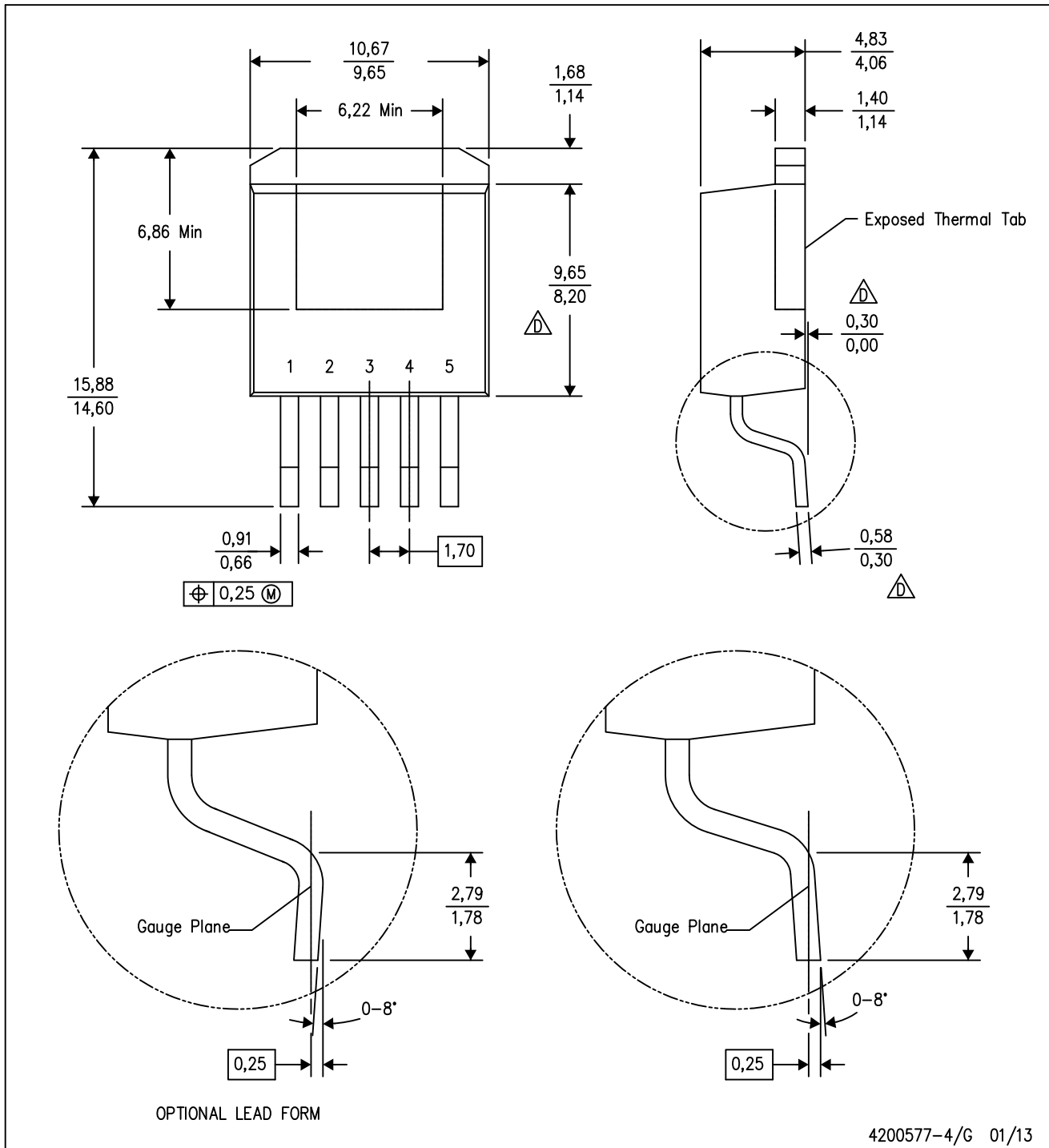

KTT (R-PSFM-G5)

PLASTIC FLANGE-MOUNT PACKAGE

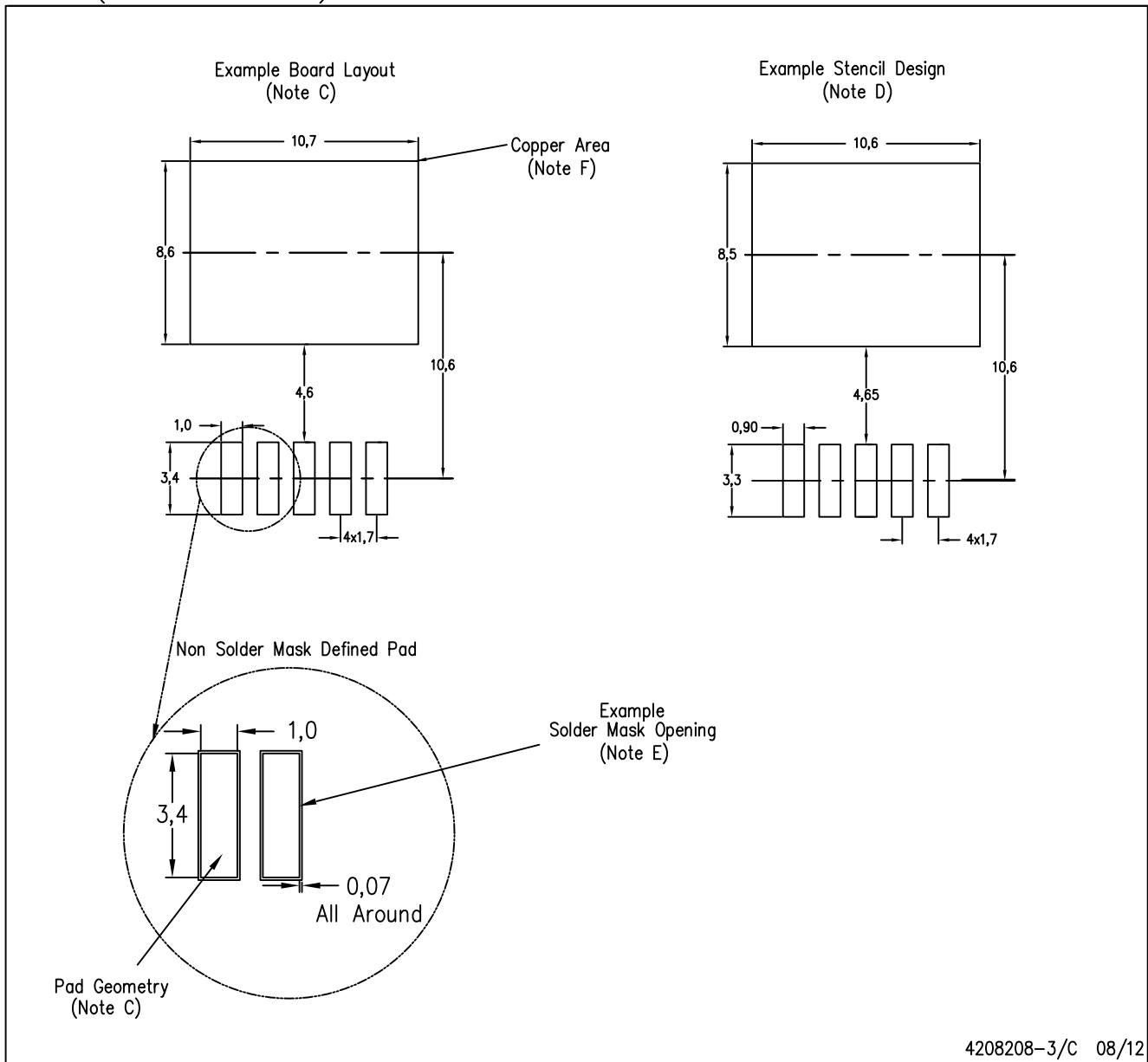

4208208-3/C 08/12

- NOTES:
- All linear dimensions are in millimeters.
  - This drawing is subject to change without notice.
  - Publication IPC-SM-782 is recommended for alternate designs.
  - Laser cutting apertures with trapezoidal walls and also rounding corners will offer better paste release. Customers should contact their board assembly site for stencil design recommendations. Refer to IPC-7525.
  - Customers should contact their board fabrication site for solder mask tolerances between and around signal pads.
  - This package is designed to be soldered to a thermal pad on the board. Refer to the Product Datasheet for specific thermal information, via requirements, and recommended thermal pad size. For thermal pad sizes larger than shown a solder mask defined pad is recommended in order to maintain the solderable pad geometry while increasing copper area.

MECHANICAL DATA

KVU (R-PSFM-G5)

PLASTIC FLANGE-MOUNT PACKAGE

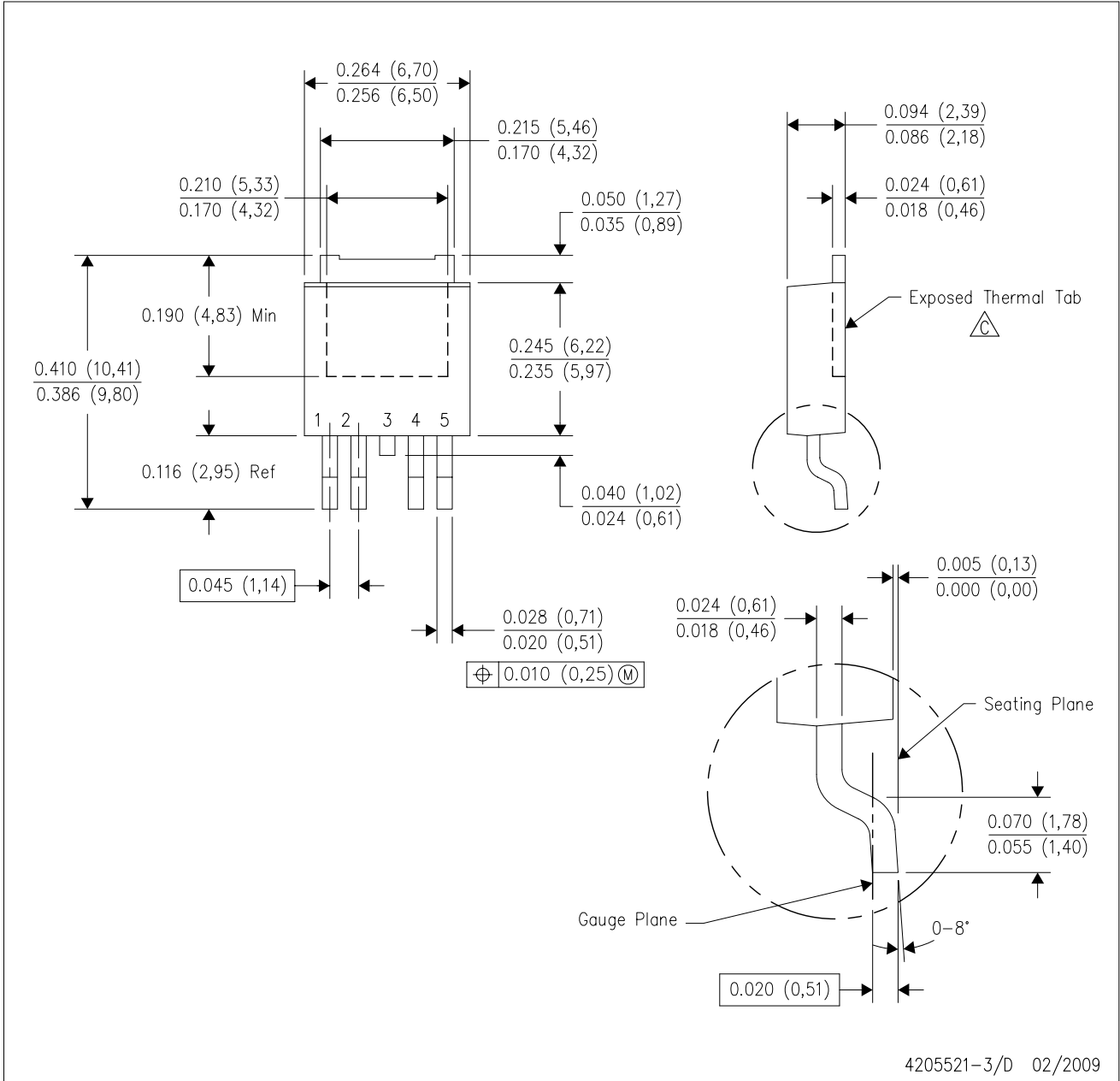

- NOTES:
- A. All linear dimensions are in inches (millimeters).
  - B. This drawing is subject to change without notice.
  - △ The center lead is in electrical contact with the exposed thermal tab.
  - D. Body Dimensions do not include mold flash or protrusions. Mold flash and protrusion shall not exceed 0.006 (0,15) per side.
  - E. Falls within JEDEC TO-252 variation AD.

KVU (R-PSFM-G5)

PLASTIC FLANGE MOUNT PACKAGE

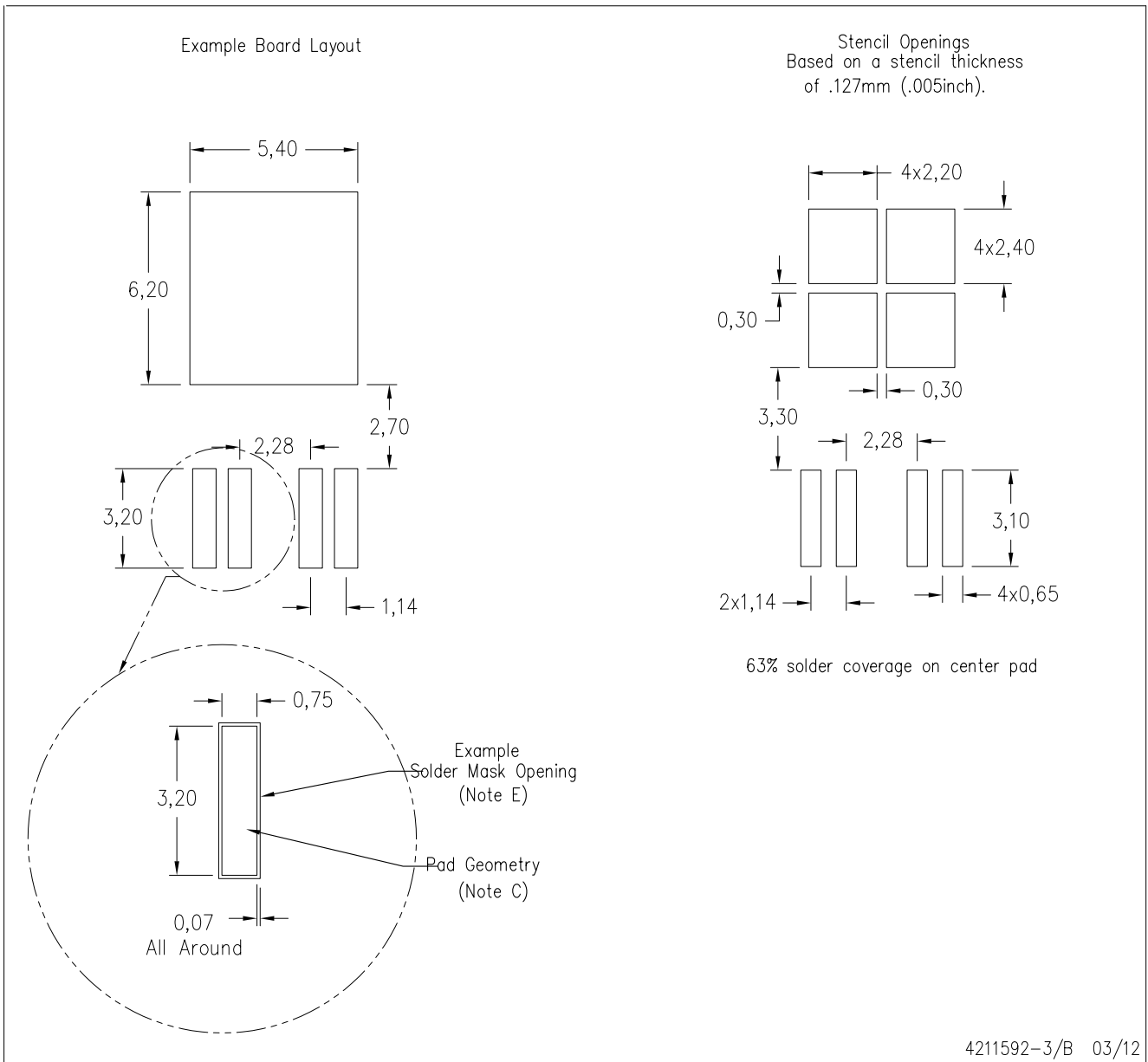

- NOTES:
- A. All linear dimensions are in millimeters.
  - B. This drawing is subject to change without notice.
  - C. Publication IPC-SM-782 is an alternate information source for PCB land pattern designs.
  - D. Laser cutting apertures with trapezoidal walls and also rounding corners will offer better paste release. Customers should contact their board assembly site for stencil design recommendations. Refer to IPC-7525 for other stencil recommendations.
  - E. Customers should contact their board fabrication site for recommended solder mask tolerances and via tenting recommendations for vias placed in thermal pad.

## IMPORTANT NOTICE

Texas Instruments Incorporated and its subsidiaries (TI) reserve the right to make corrections, enhancements, improvements and other changes to its semiconductor products and services per JESD46, latest issue, and to discontinue any product or service per JESD48, latest issue. Buyers should obtain the latest relevant information before placing orders and should verify that such information is current and complete. All semiconductor products (also referred to herein as "components") are sold subject to TI's terms and conditions of sale supplied at the time of order acknowledgment.

TI warrants performance of its components to the specifications applicable at the time of sale, in accordance with the warranty in TI's terms and conditions of sale of semiconductor products. Testing and other quality control techniques are used to the extent TI deems necessary to support this warranty. Except where mandated by applicable law, testing of all parameters of each component is not necessarily performed.

TI assumes no liability for applications assistance or the design of Buyers' products. Buyers are responsible for their products and applications using TI components. To minimize the risks associated with Buyers' products and applications, Buyers should provide adequate design and operating safeguards.

TI does not warrant or represent that any license, either express or implied, is granted under any patent right, copyright, mask work right, or other intellectual property right relating to any combination, machine, or process in which TI components or services are used. Information published by TI regarding third-party products or services does not constitute a license to use such products or services or a warranty or endorsement thereof. Use of such information may require a license from a third party under the patents or other intellectual property of the third party, or a license from TI under the patents or other intellectual property of TI.

Reproduction of significant portions of TI information in TI data books or data sheets is permissible only if reproduction is without alteration and is accompanied by all associated warranties, conditions, limitations, and notices. TI is not responsible or liable for such altered documentation. Information of third parties may be subject to additional restrictions.

Resale of TI components or services with statements different from or beyond the parameters stated by TI for that component or service voids all express and any implied warranties for the associated TI component or service and is an unfair and deceptive business practice. TI is not responsible or liable for any such statements.

Buyer acknowledges and agrees that it is solely responsible for compliance with all legal, regulatory and safety-related requirements concerning its products, and any use of TI components in its applications, notwithstanding any applications-related information or support that may be provided by TI. Buyer represents and agrees that it has all the necessary expertise to create and implement safeguards which anticipate dangerous consequences of failures, monitor failures and their consequences, lessen the likelihood of failures that might cause harm and take appropriate remedial actions. Buyer will fully indemnify TI and its representatives against any damages arising out of the use of any TI components in safety-critical applications.

In some cases, TI components may be promoted specifically to facilitate safety-related applications. With such components, TI's goal is to help enable customers to design and create their own end-product solutions that meet applicable functional safety standards and requirements. Nonetheless, such components are subject to these terms.

No TI components are authorized for use in FDA Class III (or similar life-critical medical equipment) unless authorized officers of the parties have executed a special agreement specifically governing such use.

Only those TI components which TI has specifically designated as military grade or "enhanced plastic" are designed and intended for use in military/aerospace applications or environments. Buyer acknowledges and agrees that any military or aerospace use of TI components which have **not** been so designated is solely at the Buyer's risk, and that Buyer is solely responsible for compliance with all legal and regulatory requirements in connection with such use.

TI has specifically designated certain components as meeting ISO/TS16949 requirements, mainly for automotive use. In any case of use of non-designated products, TI will not be responsible for any failure to meet ISO/TS16949.

### Products

Audio	<a href="http://www.ti.com/audio">www.ti.com/audio</a>
Amplifiers	<a href="http://amplifier.ti.com">amplifier.ti.com</a>
Data Converters	<a href="http://dataconverter.ti.com">dataconverter.ti.com</a>
DLP® Products	<a href="http://www.dlp.com">www.dlp.com</a>
DSP	<a href="http://dsp.ti.com">dsp.ti.com</a>
Clocks and Timers	<a href="http://www.ti.com/clocks">www.ti.com/clocks</a>
Interface	<a href="http://interface.ti.com">interface.ti.com</a>
Logic	<a href="http://logic.ti.com">logic.ti.com</a>
Power Mgmt	<a href="http://power.ti.com">power.ti.com</a>
Microcontrollers	<a href="http://microcontroller.ti.com">microcontroller.ti.com</a>
RFID	<a href="http://www.ti-rfid.com">www.ti-rfid.com</a>
OMAP Applications Processors	<a href="http://www.ti.com/omap">www.ti.com/omap</a>
Wireless Connectivity	<a href="http://www.ti.com/wirelessconnectivity">www.ti.com/wirelessconnectivity</a>

### Applications

Automotive and Transportation	<a href="http://www.ti.com/automotive">www.ti.com/automotive</a>
Communications and Telecom	<a href="http://www.ti.com/communications">www.ti.com/communications</a>
Computers and Peripherals	<a href="http://www.ti.com/computers">www.ti.com/computers</a>
Consumer Electronics	<a href="http://www.ti.com/consumer-apps">www.ti.com/consumer-apps</a>
Energy and Lighting	<a href="http://www.ti.com/energy">www.ti.com/energy</a>
Industrial	<a href="http://www.ti.com/industrial">www.ti.com/industrial</a>
Medical	<a href="http://www.ti.com/medical">www.ti.com/medical</a>
Security	<a href="http://www.ti.com/security">www.ti.com/security</a>
Space, Avionics and Defense	<a href="http://www.ti.com/space-avionics-defense">www.ti.com/space-avionics-defense</a>
Video and Imaging	<a href="http://www.ti.com/video">www.ti.com/video</a>

### TI E2E Community

[e2e.ti.com](http://e2e.ti.com)