

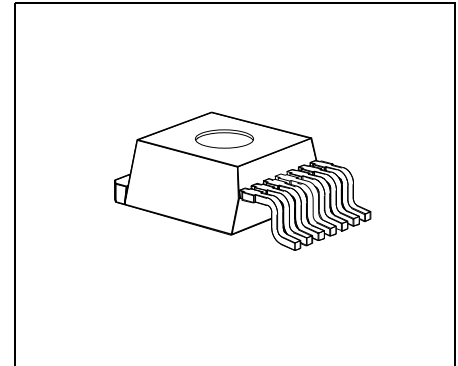

## Features

- Adjustable constant current up to 500 mA ( $\pm 5\%$ )
- Wide input voltage range up to 42 V
- Low drop voltage
- Open load detection
- Overtemperature protection
- Short circuit proof
- Reverse polarity proof
- Wide temperature range:  $-40\text{ }^{\circ}\text{C}$  to  $150\text{ }^{\circ}\text{C}$
- Green Product (RoHS compliant)
- AEC Qualified



## Functional Description

The TLE 4242 G is an integrated adjustable constant current source driving loads up to 500 mA. The output current level can be adjusted via an external resistor. The IC is designed to supply high power LEDs (e.g. Osram Dragon LA W57B) under the severe conditions of automotive applications resulting in constant brightness and extended LED lifetime. It is provided in the surface mounted PG-TO263-7-1 package. Protection circuits prevent damage to the device in case of overload, short circuit, reverse polarity and overheat. The connected LEDs are protected against reverse polarity as well as excess voltages up to 45 V.

The integrated PWM input of the TLE 4242 G permits LED brightness regulation by pulse width modulation. Due to the high input impedance of the PWM input the LED driver can be operated as a protected high side switch.

Type	Package
TLE 4242 G	PG-TO263-7-1

### Circuit Description

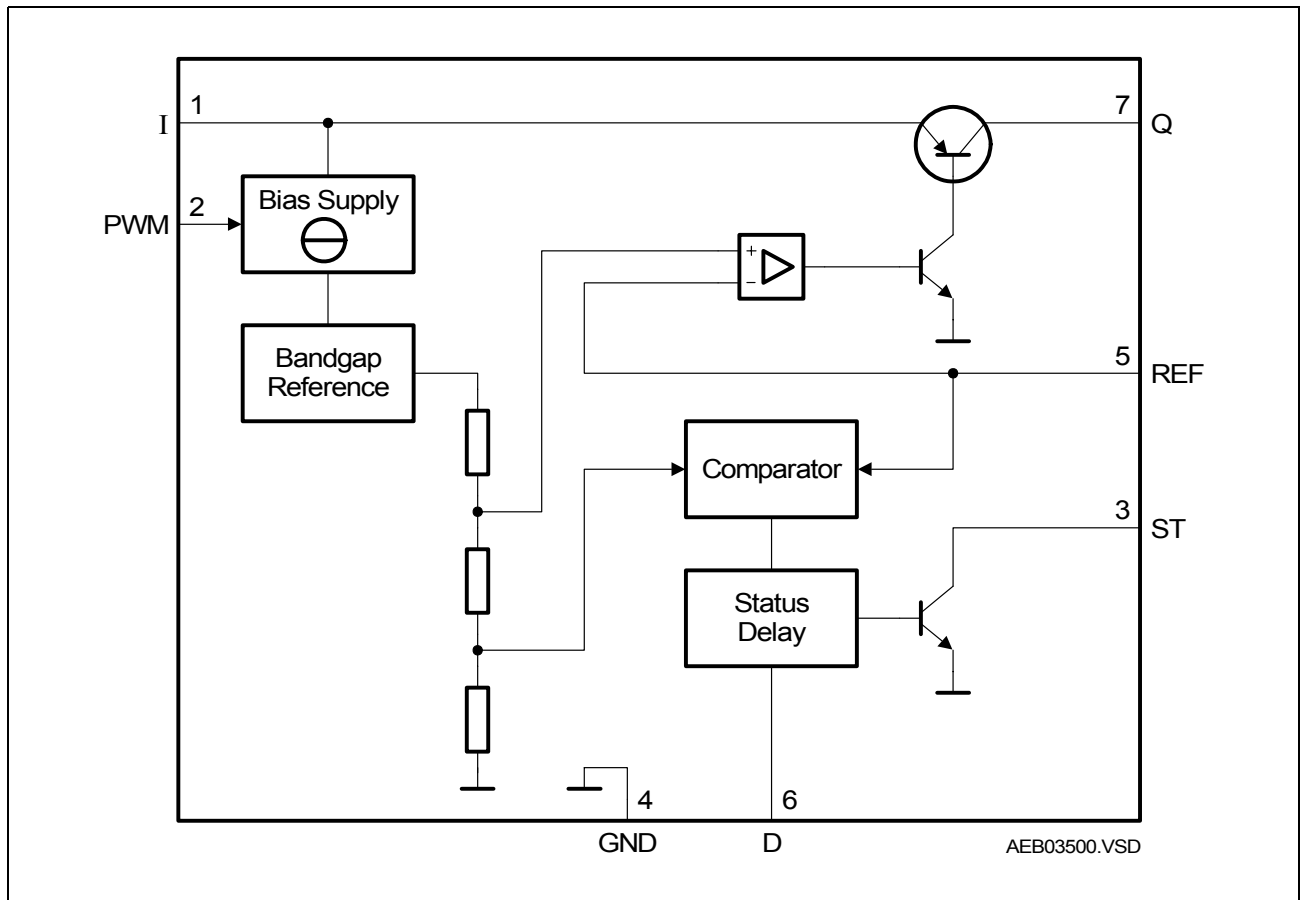

**Figure 1 Block Diagram**

An external shunt resistor in the ground path of the connected LEDs is used to sense the LED current. A regulation loop holds the voltage drop at the shunt resistor on a constant level of typ. 177 mV. Selecting the shunt resistance permits to adjust the appropriate constant current level. The typ. output current calculates

$$I_{Q, \text{typ}} = \frac{V_{\text{REF}}}{R_{\text{REF}}} \tag{1}$$

where  $V_{\text{REF}}$  is the reference voltage with a typical level of 177 mV (see [Page 10](#)). The equation applies in a range of  $0.39 \Omega \leq R_{\text{REF}} \leq 1.8 \Omega$ .

The output current is shown as a function of the reference resistance on [Page 10](#). With the PWM input the LED brightness can be regulated via duty cycle. Also PWM = L sets the TLE 4242 in sleep mode resulting in a very low current consumption of  $\ll 1 \mu\text{A}$  typ. Due to the high impedance of the PWM input (see [“PWM Pin Input Current versus PWM Voltage” on Page 11](#)) the PWM pin can thus also be used as an enable input.

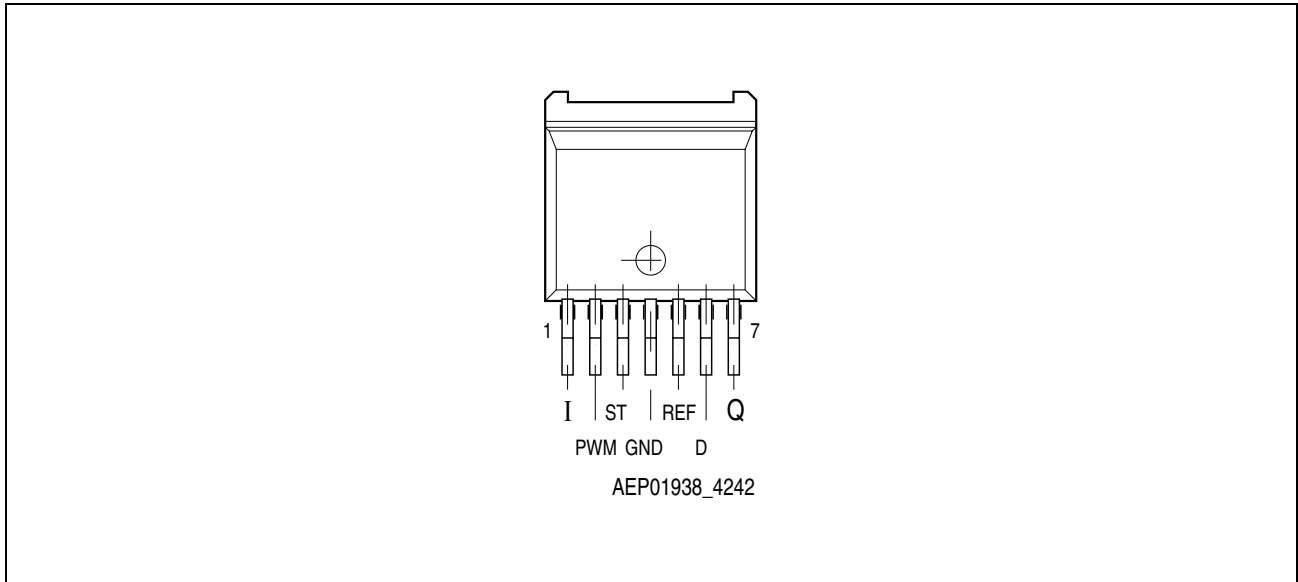
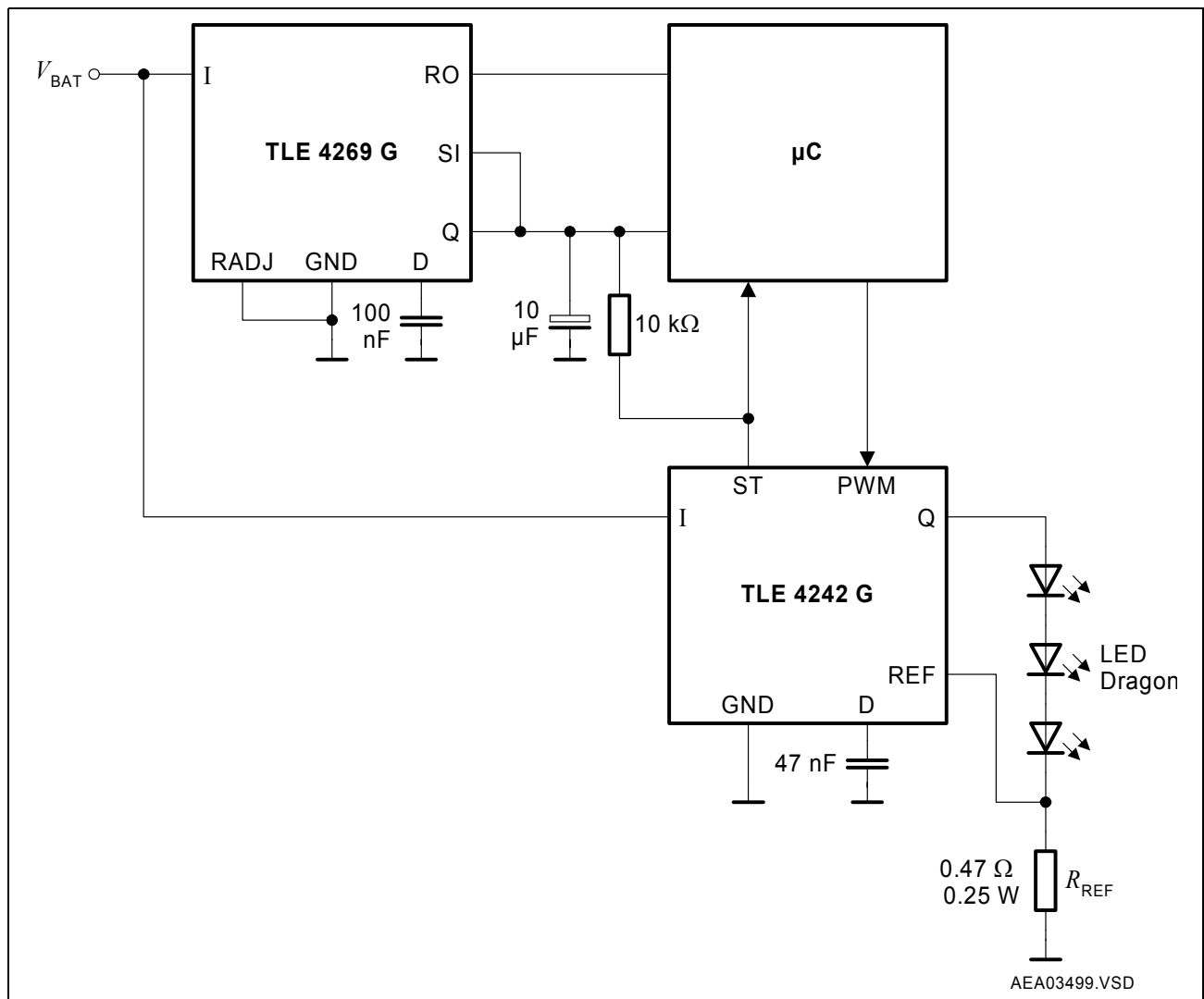

**Figure 2 Pin Configuration (top view)**

**Table 1 Pin Definitions and Functions**

Pin No.	Symbol	Function
1	I	<b>Input</b> ; block to GND directly at the IC with a 100 nF ceramic capacitor.
2	PWM	<b>Pulse Width Modulation Input</b> ; if not needed connect to I
3	ST	<b>Status Output</b> ; open collector output, connect to external pull-up resistor ( $R_{pull-up} \geq 4.7 \text{ k}\Omega$ ).
4	GND	<b>Ground</b>
5	REF	<b>Reference Input</b> ; connect to shunt resistor.
6	D	<b>Status Delay</b> ; connect to GND via an optional capacitor to set status reaction delay. Leave open if no ST delay is needed.
7	Q	<b>Output</b>

### Application Information



**Figure 3 Application Circuit**

**Figure 3** shows a typical application with the TLE 4242 G LED driver. The 3 LEDs are driven with an adequate supply current adjusted by the resistor  $R_{REF}$ . Thus brightness variations due to forward voltage spread of the LEDs are prevented. The luminosity spread arising from the LED production process can be compensated via software by an appropriate duty cycle applied to the PWM pin. Hence selection of the LEDs to forward voltage as well as to luminosity classes can be spared. The minimum supply voltage calculates as the sum of the LED forward voltages, the TLE 4242 G drop voltage (max. 0.7 V at a LED current of 300 mA) and the max. voltage drop at the shunt resistor  $R_{REF}$  of max. 185 mV.

The status output of the LED driver (ST) detects an open load condition enabling to supervise correct LED function. A LED failure is detected if the voltage drop at the shunt resistor  $R_{REF}$  falls below typ. 25 mV. In this case the status output pin ST is set low after a delay time adjustable via an optional capacitor connected to the pin D.

The functionality of the ST and PWM as well as their timings are shown in **Figure 4**. The Status delay can be adjusted via the capacitor connected to the timing Pin D. The delay time scales in linear way with the capacitance  $C_D$ :

$$t_{STHL,typ} = \frac{C_D}{47 \text{ nF}} \times 10 \text{ ms} \quad t_{STLH,typ} = \frac{C_D}{47 \text{ nF}} \times 10 \mu\text{s} \quad (2)$$

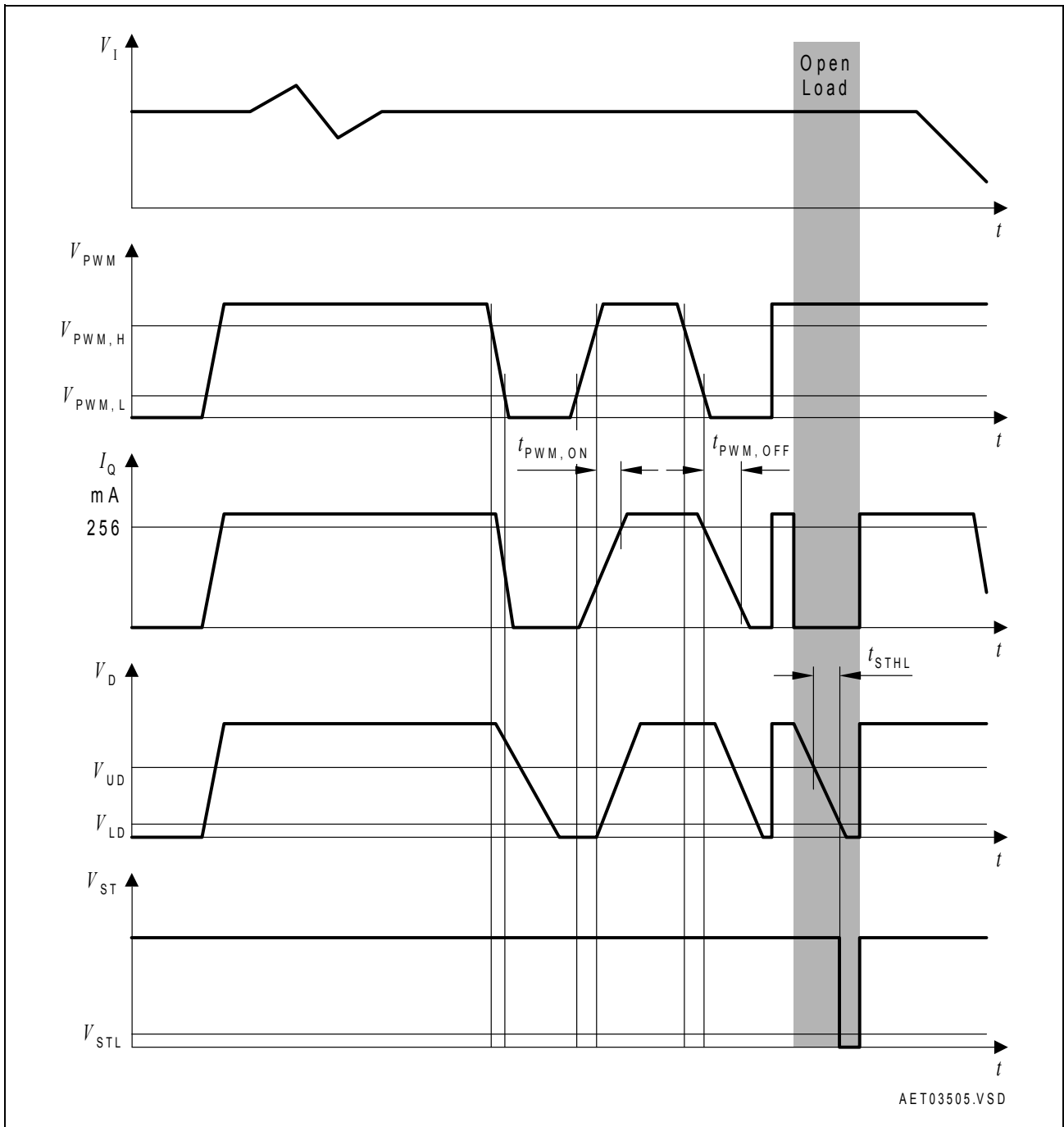

**Figure 4** Function and Timing Diagram

**Table 2 Absolute Maximum Ratings**
 $-40\text{ °C} < T_j < 150\text{ °C}$ 

Parameter	Symbol	Limit Values		Unit	Remarks
		Min.	Max.		
<b>Input</b>					
Voltage	$V_I$	-42	45	V	–
Current	$I_I$	–	–	mA	internally limited
<b>Output</b>					
Voltage	$V_Q$	-1	40	V	–
Current	$I_Q$	–	–	mA	internally limited
<b>Status Output</b>					
Voltage	$V_{ST}$	-0.3	40	V	–
Current	$I_{ST}$	-5	5	mA	–
<b>Status Delay</b>					
Voltage	$V_D$	-0.3	7	V	–
<b>Reference Input</b>					
Voltage	$V_{REF}$	-1	16	V	–
Current	$I_{REF}$	-2	2	mA	–
<b>Pulse Width Modulation Input</b>					
Voltage	$V_{PWM}$	-40	40	V	–
Current	–	-1	1	mA	–
<b>Temperatures</b>					
Junction temperature	$T_j$	-40	150	°C	–
Storage temperature	$T_{stg}$	-50	150	°C	–
<b>Thermal Resistances</b>					
Junction ambient	$R_{thja}$	–	78	K/W	Footprint only <sup>1)</sup>
		–	52	K/W	300mm <sup>2</sup> heat sink area
		–	39	K/W	600mm <sup>2</sup> heat sink area
Junction case	$R_{thjc}$	–	3	K/W	–

1) Worst case regarding peak temperature; mounted on PCB FR4, 80 × 80 × 1.5 mm<sup>3</sup>, 35 μm Cu.

*Note: Maximum ratings are absolute ratings; exceeding any one of these values may cause irreversible damage to the integrated circuit.*

**Table 3      Operating Range**

Parameter	Symbol	Limit Values		Unit	Remarks
		Min.	Max.		
Input voltage	$V_I$	4.5	42	V	–
Status output voltage	$V_{ST}$	–	16	V	–
Status Delay capacitance	$C_D$	0	2.2	$\mu\text{F}$	–
PWM voltage	$V_{PWM}$	0	40	V	–
Junction temperature	$T_j$	-40	150	$^{\circ}\text{C}$	–
Reference resistor	$R_{REF}$	0	1.8	$\Omega$	–

**Table 4 Electrical Characteristics**
 $V_I = 13.5 \text{ V}$ ;  $R_{REF} = 0.47 \text{ } \Omega$ ;  $V_{PWM} \geq V_{PWM,H}$ ;  $-40 \text{ } ^\circ\text{C} < T_j < 150 \text{ } ^\circ\text{C}$ ; all voltages with respect to ground; positive current defined flowing into pin; unless otherwise specified

Parameter	Symbol	Limit Values			Unit	Test Condition
		Min.	Typ.	Max.		
Current consumption off mode	$I_{qOFF}$	–	0.1	2	$\mu\text{A}$	PWM = L, $T_j < 85 \text{ } ^\circ\text{C}$
Current consumption	$I_{qL}$	–	12	22	mA	$V_Q = 6.6 \text{ V}$

**Output**

Output current	$I_Q$	357	376	395	mA	$V_Q - V_{REF}^{1)} = 6.6 \text{ V}$
		168	177	185	mA	$V_Q - V_{REF} = 6.6 \text{ V}$ ; $R_{REF} = 1.0 \text{ } \Omega$
		431	454	476	mA	$V_Q - V_{REF} = 6.6 \text{ V}$ ; $R_{REF} = 0.39 \text{ } \Omega$
		357	376	395	mA	$5.4 \text{ V} \leq V_Q - V_{REF} \leq 7.8 \text{ V}$ ; $9 \text{ V} \leq V_I \leq 16 \text{ V}$
Output current limit	$I_{Qmax}$	–	600	–	mA	$R_{REF} = 0 \text{ } \Omega$
Drop voltage	$V_{dr}$	–	0.35	0.7	V	$I_Q = 300 \text{ mA}$

**PWM Input**

PWM high level	$V_{PWM,H}$	2.6	–	–	V	–
PWM low level	$V_{PWM,L}$	–	–	0.7	V	–
PWM input current high level	$I_{PWM,H}$	–	220	500	$\mu\text{A}$	$V_{PWM} = 5.0 \text{ V}$
PWM input current low level	$I_{PWM,L}$	-1	–	1	$\mu\text{A}$	$V_{PWM} = 0.0 \text{ V}$
Turn on delay time	$t_{PWM,ON}$	0	15	40	$\mu\text{s}$	70% of $I_{Qnom}$ , see <a href="#">Figure 4</a>
Turn off delay time	$t_{PWM,OFF}$	0	15	40	$\mu\text{s}$	30% of $I_{Qnom}$ , see <a href="#">Figure 4</a>



**Table 4 Electrical Characteristics (cont'd)**

$V_I = 13.5\text{ V}$ ;  $R_{REF} = 0.47\ \Omega$ ;  $V_{PWM} \geq V_{PWM,H}$ ;  $-40\text{ }^\circ\text{C} < T_j < 150\text{ }^\circ\text{C}$ ; all voltages with respect to ground; positive current defined flowing into pin; unless otherwise specified

Parameter	Symbol	Limit Values			Unit	Test Condition
		Min.	Typ.	Max.		
<b>Reference</b>						
Reference Voltage	$V_{REF}$	168	177	185	mV	$0.39 < R_{REF} < 1.0\ \Omega$
Reference Input Current	$I_{REF}$	-1	0.1	1	$\mu\text{A}$	$V_{REF} = 180\text{ mV}$
<b>Status Output</b>						
Lower status switching threshold	$V_{IQL}$	15	25	–	mV	ST = L
Upper status switching threshold	$V_{IQH}$	–	30	40	mV	ST = H
Status low voltage	$V_{STL}$	–	–	0.4	V	$I_{ST} = 1.5\text{ mA}$
Leakage current	$I_{STLK}$	–	–	5	$\mu\text{A}$	$V_{ST} = 5.0\text{ V}$
<b>Status Delay</b>						
Status reaction delay	$t_{STHL}$	6	10	14	ms	$C_D = 47\text{ nF}$ , ST H $\rightarrow$ L
Status release delay	$t_{STLH}$	–	10	20	$\mu\text{s}$	$C_D = 47\text{ nF}$ , ST L $\rightarrow$ H

1)  $V_Q - V_{REF}$  equals the forward voltage sum of the connected LEDs, see [Figure 3](#).

### Typical Performance Characteristics

**Output Current versus External Resistor**

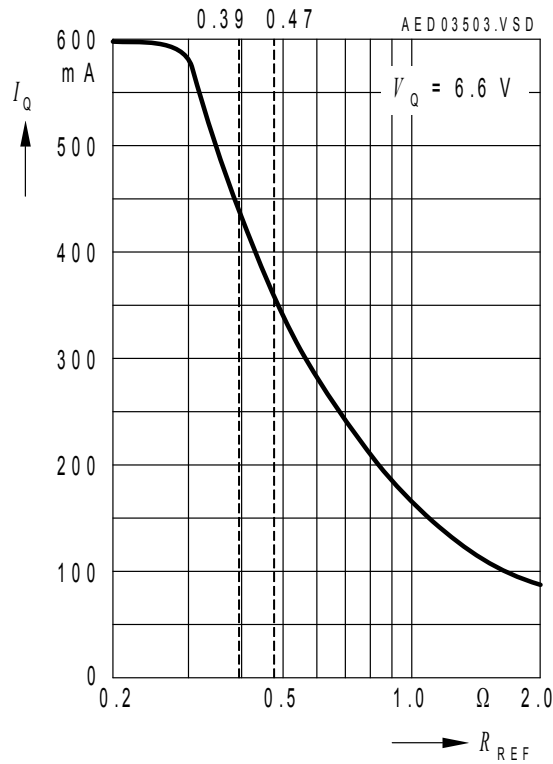

**Reference Voltage versus Junction Temperature**

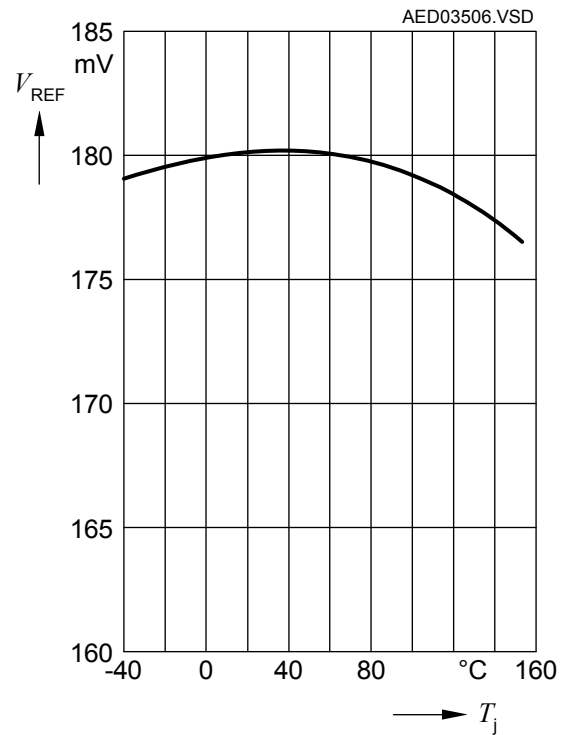

**Output Current versus Supply Voltage**

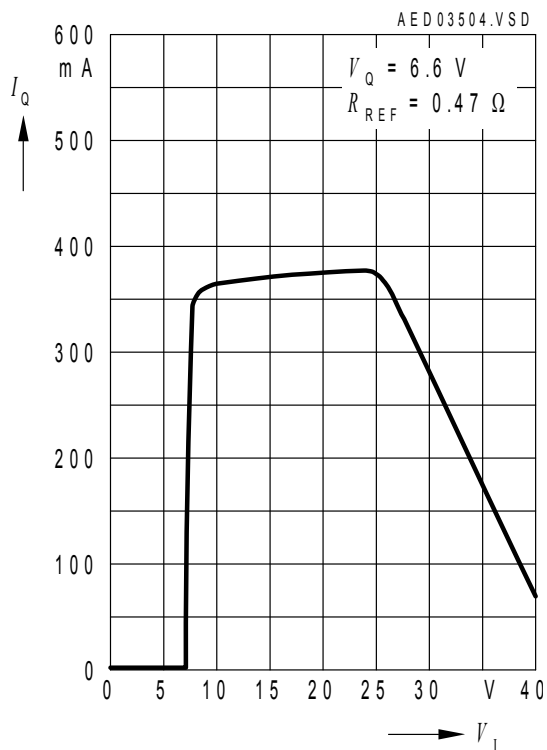

**PWM Pin Input Current versus PWM Voltage**

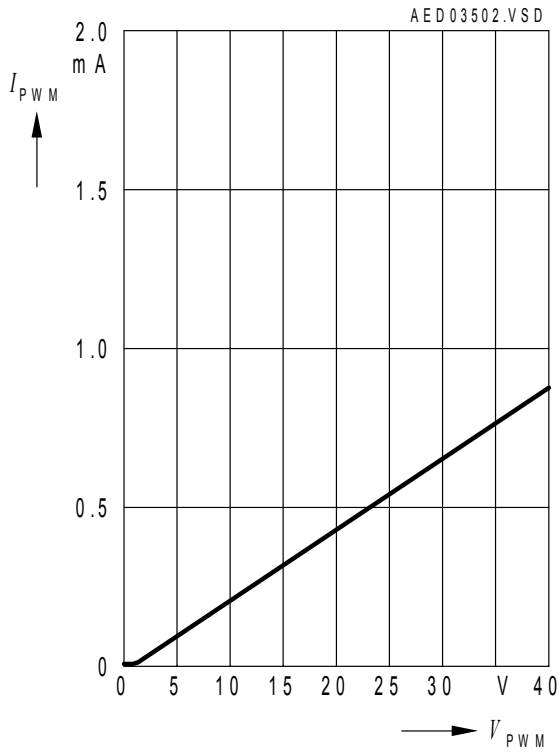

**PWM Pin Input Current versus PWM Voltage**

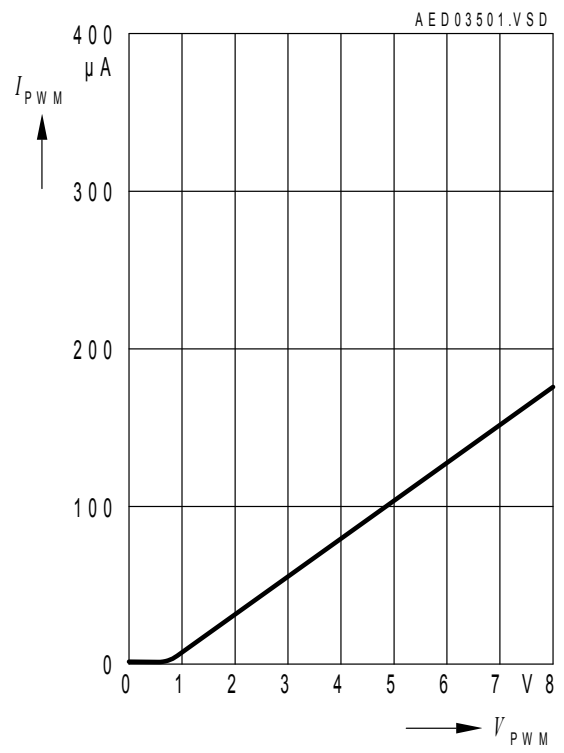

Package Outlines

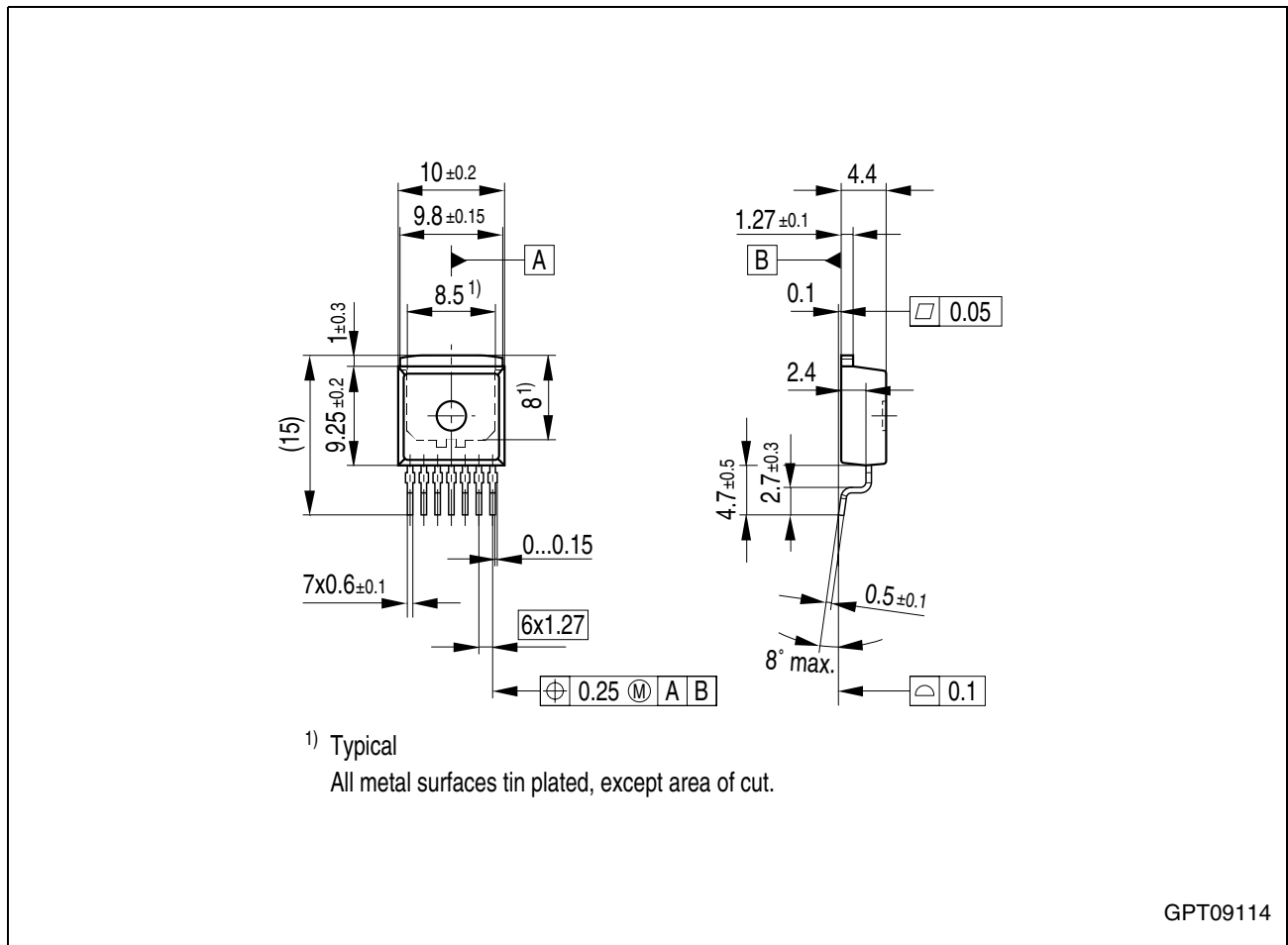

Figure 5 PG-T0263-7-1 (Plastic Transistor Single Outline)

Green Product (RoHS compliant)

To meet the world-wide customer requirements for environmentally friendly products and to be compliant with government regulations the device is available as a green product. Green products are RoHS-Compliant (i.e Pb-free finish on leads and suitable for Pb-free soldering according to IPC/JEDEC J-STD-020).

You can find all of our packages, sorts of packing and others in our Infineon Internet Page “Products”: <http://www.infineon.com/products>.

SMD = Surface Mounted Device

Dimensions in mm

---

**Revision History**

<b>Version</b>	<b>Date</b>	<b>Changes</b>
Rev. 1.0	2004-01-01	Initial version
Rev. 1.1	2007-03-20	Initial version of RoHS-compliant derivate of TLE 4242 G <b>Page 1</b> : AEC certified statement added <b>Page 1</b> and <b>Page 12</b> : RoHS compliance statement and Green product feature added <b>Page 1</b> and <b>Page 12</b> : Package changed to RoHS compliant version Legal Disclaimer updated

**Edition 2007-03-20**

**Published by  
Infineon Technologies AG  
81726 Munich, Germany**

**© 2007 Infineon Technologies AG  
All Rights Reserved.**

#### **Legal Disclaimer**

The information given in this document shall in no event be regarded as a guarantee of conditions or characteristics. With respect to any examples or hints given herein, any typical values stated herein and/or any information regarding the application of the device, Infineon Technologies hereby disclaims any and all warranties and liabilities of any kind, including without limitation, warranties of non-infringement of intellectual property rights of any third party.

#### **Information**

For further information on technology, delivery terms and conditions and prices, please contact the nearest Infineon Technologies Office ([www.infineon.com](http://www.infineon.com)).

#### **Warnings**

Due to technical requirements, components may contain dangerous substances. For information on the types in question, please contact the nearest Infineon Technologies Office.

Infineon Technologies components may be used in life-support devices or systems only with the express written approval of Infineon Technologies, if a failure of such components can reasonably be expected to cause the failure of that life-support device or system or to affect the safety or effectiveness of that device or system. Life support devices or systems are intended to be implanted in the human body or to support and/or maintain and sustain and/or protect human life. If they fail, it is reasonable to assume that the health of the user or other persons may be endangered.