

Infineon[®] LITIX[™] Basic

TLD1314EL

3 Channel High Side Current Source

Data Sheet

Rev. 1.1, 2015-03-24

Automotive

1	Overview	3
2	Block Diagram	5
3	Pin Configuration	6
3.1	Pin Assignment	6
3.2	Pin Definitions and Functions	7
4	General Product Characteristics	8
4.1	Absolute Maximum Ratings	8
4.2	Functional Range	9
4.3	Thermal Resistance	9
5	DEN Pin	10
5.1	Electrical Characteristics Internal Supply / DEN Pin	11
6	IN_SET Pin	13
6.1	Output Current Adjustment via RSET	13
6.2	Smart Input Pin	13
7	ST Pin	16
7.1	Diagnosis Selector	16
7.2	Diagnosis Output	16
7.3	Disable Input	16
8	Load Diagnosis	18
8.1	Open Load	18
8.2	Short Circuit to GND detection	19
8.3	Electrical Characteristics IN_SET Pin and Load Diagnosis	21
9	Power Stage	23
9.1	Protection	23
9.1.1	Over Load Behavior	23
9.1.2	Reverse Battery Protection	23
9.2	Electrical Characteristics Power Stage	24
10	Application Information	26
10.1	Further Application Information	26
11	Package Outlines	27
12	Revision History	28



1 Overview

Features

- 3 Channel device with integrated output stages (current sources), optimized to drive LEDs
- Output current up to 120mA per channel
- Low current consumption
- PWM-operation supported via VS-pin
- Output current adjustable via external low power resistor and possibility to connect PTC resistor for LED protection during over temperature conditions
- Reverse polarity protection
- Overload protection
- Undervoltage detection
- Open load and short circuit to GND diagnosis
- Wide temperature range: $-40\text{ °C} < T_j < 150\text{ °C}$
- PG-SSOP14 package with exposed heatslug
- Green Product (RoHS compliant)
- AEC Qualified



PG-SSOP14

Description

The LITIX™ Basic TLD1314EL is a three channel high side driver IC with integrated output stages. It is designed to control LEDs with a current up to 120 mA. In typical automotive applications the device is capable to drive i.e. 3 red LEDs per chain (total 9 LEDs) with a current up to 60mA, which is limited by thermal cooling aspects. The output current is controlled practically independent of load and supply voltage changes.

Table 1 Product Summary

Operating voltage	$V_{S(nom)}$	5.5 V... 40 V
Maximum voltage	$V_{S(max)}$ $V_{OUTx(max)}$	40 V
Nominal output (load) current	$I_{OUTx(nom)}$	60 mA when using a supply voltage range of 8V - 18V (e.g. Automotive car battery). Currents up to $I_{OUT(max)}$ possible in applications with low thermal resistance R_{thJA}
Maximum output (load) current	$I_{OUTx(max)}$	120 mA; depending on thermal resistance R_{thJA}
Output current accuracy at $R_{SET} = 12\text{ k}\Omega$	k_{LT}	$750 \pm 7\%$

Type	Package	Marking
TLD1314EL	PG-SSOP14	TLD1314EL

Protective functions

- ESD protection
- Under voltage lock out
- Over Load protection
- Over Temperature protection
- Reverse Polarity protection

Diagnostic functions

- Diagnosis enable function
- OL detection
- SC to Vs (indicated by OL diagnosis)
- SC to GND detection

Applications

Designed for exterior LED lighting applications such as tail/brake light, turn indicator, position light, side marker,...

The device is also well suited for interior LED lighting applications such as ambient lighting, interior illumination and dash board lighting.

2 Block Diagram

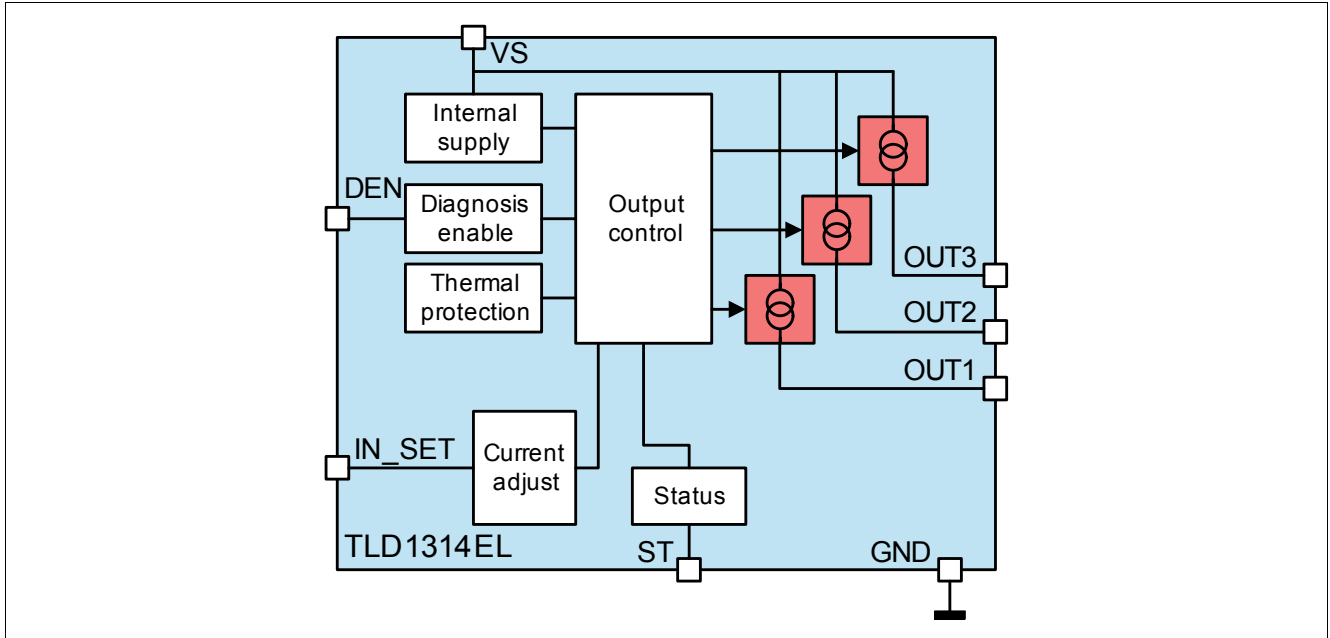

Figure 1 Basic Block Diagram

3 Pin Configuration

3.1 Pin Assignment

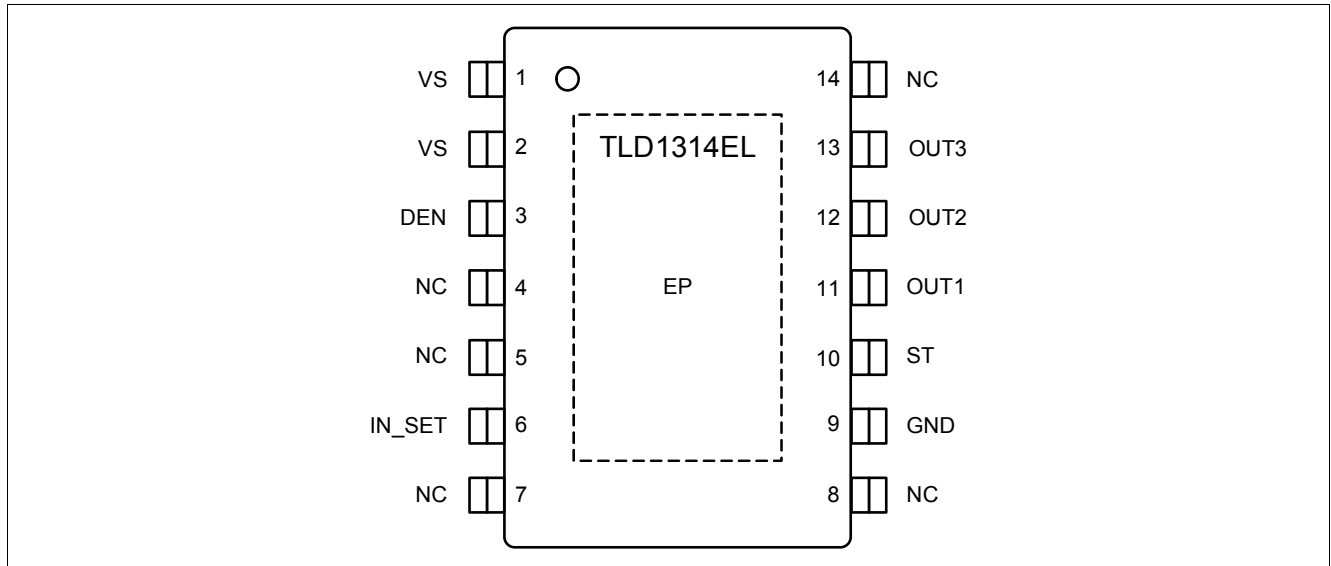

Figure 2 Pin Configuration

3.2 Pin Definitions and Functions

Pin	Symbol	Input/ Output	Function
1, 2	VS	–	Supply Voltage ; battery supply, connect a decoupling capacitor (100 nF - 1 µF) to GND
3	DEN	I	Diagnosis enable pin
4	NC	–	Pin not connected
5	NC	–	Pin not connected
6	IN_SET	I/O	Input / SET pin ; Connect a low power resistor to adjust the output current
8	NC	–	Pin not connected
9	GND	–	¹⁾ Ground
10	ST	I/O	Status pin
11	OUT1	O	Output 1
12	OUT2	O	Output 2
13	OUT3	O	Output 3
14	NC	–	Pin not connected
Exposed Pad	GND	–	¹⁾ Exposed Pad ; connect to GND in application

1) Connect all GND-pins together.

4 General Product Characteristics

4.1 Absolute Maximum Ratings

Absolute Maximum Ratings ¹⁾

$T_j = -40\text{ °C}$ to $+150\text{ °C}$; all voltages with respect to ground, positive current flowing into pin for input pins (I), positive currents flowing out of the I/O and output pins (O) (unless otherwise specified)

Pos.	Parameter	Symbol	Limit Values		Unit	Conditions
			Min.	Max.		
Voltages						
4.1.1	Supply voltage	V_S	-16	40	V	–
4.1.2	Diagnosis enable voltage DEN	V_{DEN}	-16	40	V	–
4.1.3	Diagn. enable voltage DEN related to V_S	$V_{DEN(VS)}$	$V_S - 40$	$V_S + 16$	V	–
4.1.4	Diagn. enable voltage DEN related to V_{OUTx} $V_{DEN} - V_{OUTx}$	$V_{DEN} - V_{OUTx}$	-16	40	V	–
4.1.5	Output voltage	V_{OUTx}	-1	40	V	–
4.1.6	Power stage voltage $V_{PS} = V_S - V_{OUTx}$	V_{PS}	-16	40	V	–
4.1.7	IN_SET voltage	V_{IN_SET}	-0.3	6	V	–
4.1.8	Status voltage	V_{ST}	-0.3	6	V	–
Currents						
4.1.9	IN_SET current	I_{IN_SET}	–	2 8	mA	– Diagnosis output
4.1.10	Output current	I_{OUTx}	–	130	mA	–
Temperatures						
4.1.11	Junction temperature	T_j	-40	150	°C	–
4.1.12	Storage temperature	T_{stg}	-55	150	°C	–
ESD Susceptibility						
4.1.13	ESD resistivity to GND	V_{ESD}	-2	2	kV	Human Body Model (100 pF via 1.5 kΩ) ²⁾
4.1.14	ESD resistivity all pins to GND	V_{ESD}	-500	500	V	CDM ³⁾
4.1.15	ESD resistivity corner pins to GND	V_{ESD}	-750	750	V	CDM ³⁾

1) Not subject to production test, specified by design

2) ESD susceptibility, Human Body Model "HBM" according to ANSI/ESDA/JEDEC JS-001-2011

3) ESD susceptibility, Charged Device Model "CDM" according to JESD22-C101E

Note: Stresses above the ones listed here may cause permanent damage to the device. Exposure to absolute maximum rating conditions for extended periods may affect device reliability.

Note: Integrated protection functions are designed to prevent IC destruction under fault conditions described in the data sheet. Fault conditions are considered as "outside" normal operating range. Protection functions are not designed for continuous repetitive operation.

4.2 Functional Range

Pos.	Parameter	Symbol	Limit Values		Unit	Conditions
			Min.	Max.		
4.2.16	Supply voltage range for normal operation	$V_{S(nom)}$	5.5	40	V	–
4.2.17	Power on reset threshold	$V_{S(POR)}$	–	5	V	$R_{SET} = 12\text{ k}\Omega$ $I_{OUTx} = 80\% I_{OUTx(nom)}$ $V_{OUTx} = 2.5\text{ V}$
4.2.18	Junction temperature	T_j	-40	150	°C	–

Note: Within the functional range the IC operates as described in the circuit description. The electrical characteristics are specified within the conditions given in the related electrical characteristics table.

4.3 Thermal Resistance

Pos.	Parameter	Symbol	Limit Values			Unit	Conditions
			Min.	Typ.	Max.		
4.3.1	Junction to Case	R_{thJC}	–	8	10	K/W	^{1) 2)}
4.3.2	Junction to Ambient 1s0p board	R_{thJA1}	–	61	–	K/W	^{1) 3)} $T_a = 85\text{ °C}$ $T_a = 135\text{ °C}$
			–	56	–		
4.3.3	Junction to Ambient 2s2p board	R_{thJA2}	–	45	–	K/W	^{1) 4)} $T_a = 85\text{ °C}$ $T_a = 135\text{ °C}$
			–	43	–		

- 1) Not subject to production test, specified by design. Based on simulation results.
- 2) Specified R_{thJC} value is simulated at natural convection on a cold plate setup (all pins and the exposed Pad are fixed to ambient temperature). $T_a = 85\text{ °C}$, Total power dissipation 1.5 W.
- 3) The R_{thJA} values are according to Jedec JESD51-3 at natural convection on 1s0p FR4 board. The product (chip + package) was simulated on a 76.2 x 114.3 x 1.5 mm³ board with 70µm Cu, 300 mm² cooling area. Total power dissipation 1.5 W distributed statically and homogeneously over all power stages.
- 4) The R_{thJA} values are according to Jedec JESD51-5,-7 at natural convection on 2s2p FR4 board. The product (chip + package) was simulated on a 76.2 x 114.3 x 1.5 mm³ board with 2 inner copper layers (outside 2 x 70 µm Cu, inner 2 x 35µm Cu). Where applicable, a thermal via array under the exposed pad contacted the first inner copper layer. Total power dissipation 1.5 W distributed statically and homogeneously over all power stages.

5 DEN Pin

The DEN pin is a single function pin:

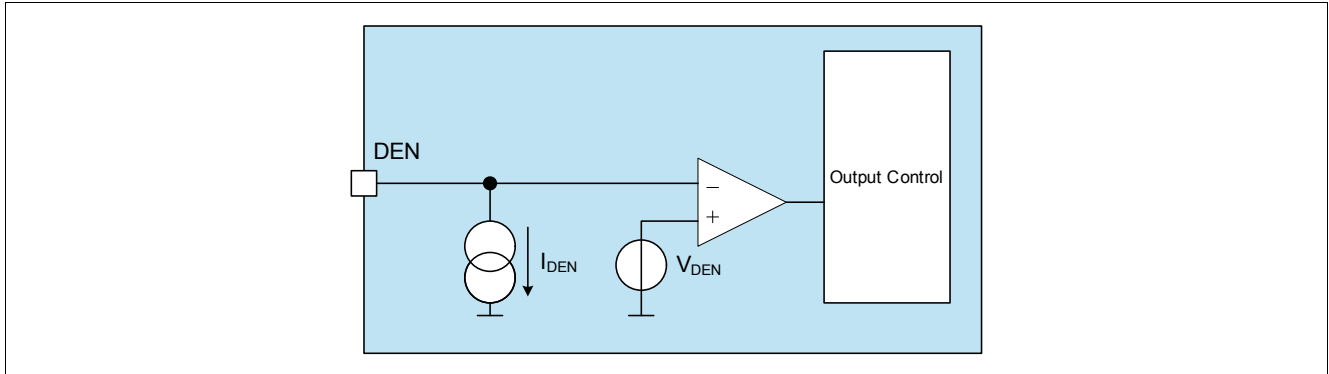

Figure 3 Block Diagram DEN pin

This pin is used to activate or deactivate the device internal diagnosis functions. The diagnostic functions are described in [Chapter 6.2](#), [Chapter 7](#) and [Chapter 8](#). The diagnosis is activated, if the voltage applied at the DEN pin V_{DEN} is higher than $V_{DEN(act)}$. The diagnosis is disabled for voltages below $V_{DEN(dis)}$.

A possibility to use the DEN pin is via a Zener diode, which is connected between V_S and DEN pin. A circuit example is shown in the application information section [Chapter 10](#).

The diagnosis is activated, if the following condition is fulfilled:

$$V_S \geq V_{DEN(act)} + V_{ZD} \tag{1}$$

The current consumption on the DEN pin has to be considered for the total device current consumption. The current is specified in [Pos. 5.1.8](#). The typical current consumption $I_{DEN(H)}$ as a function of the supply voltage V_S for a Zener diode voltage of $V_{ZD} = 6\text{ V}$ is shown in the following diagram.

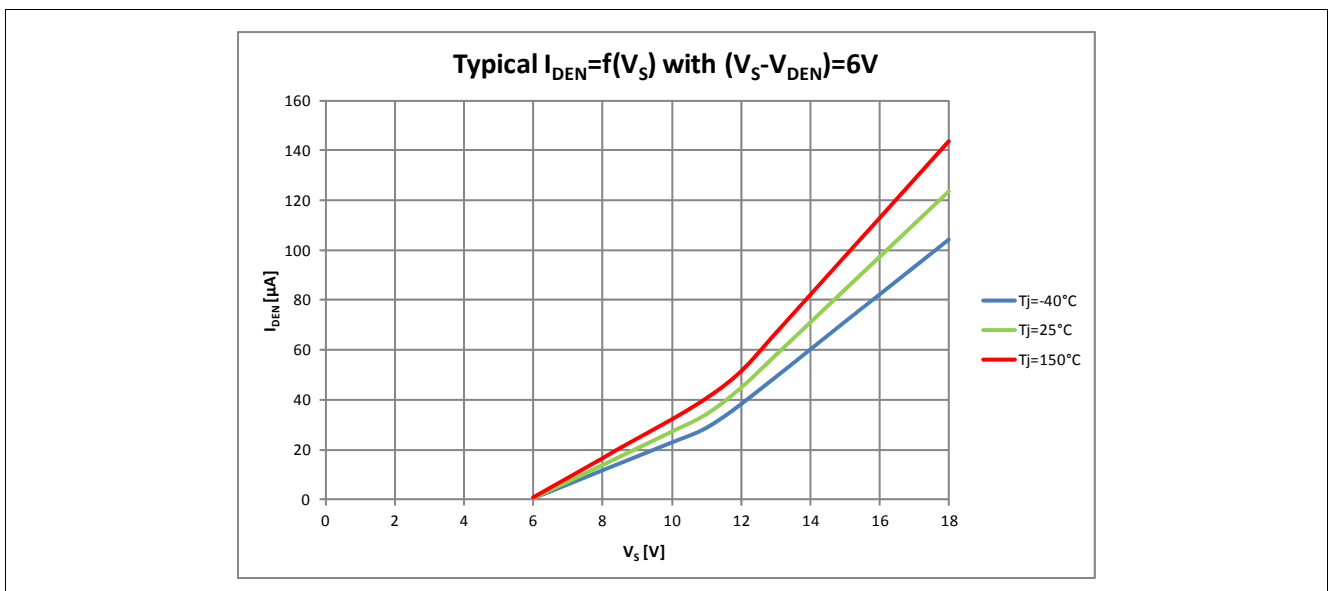
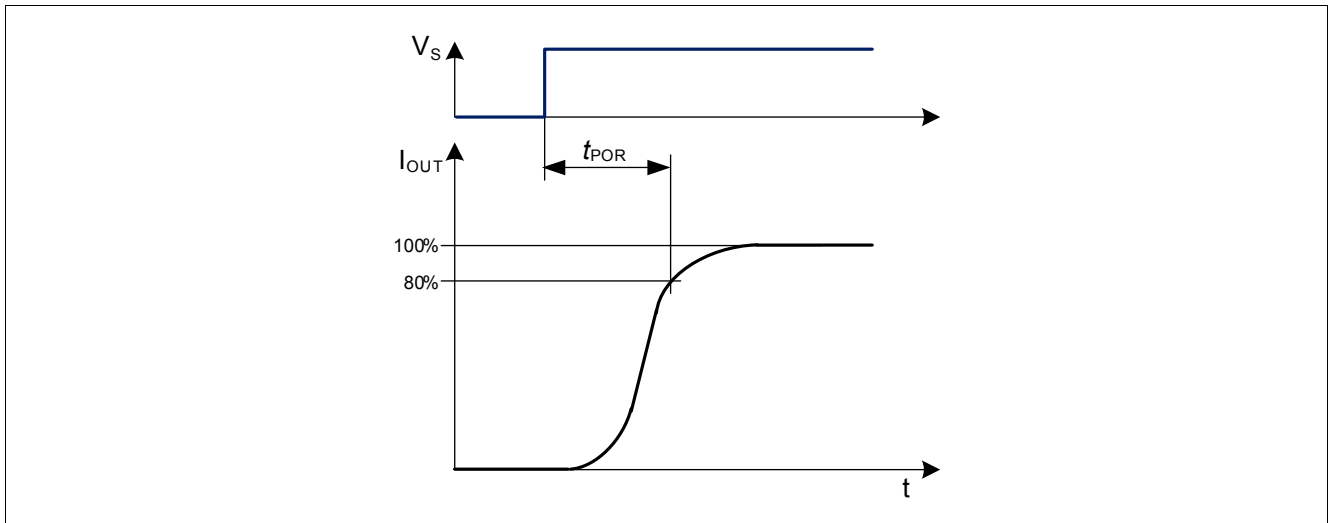

Figure 4 Typical $I_{DEN(H)}$ current for a Zener diode voltage of 6V

The device and channel turn on is independent of the V_{DEN} -voltage. After applying a supply voltage the device is activated after the power on reset time t_{POR} .

Figure 5 Power on reset

The DEN voltage V_{DEN} does not influence the disable function via the ST pin. If $V_{\text{DEN}} < V_{\text{DEN}(\text{dis})}$ the device can still be disabled via the ST pin, if $V_{\text{ST}} > V_{\text{ST}(\text{H})}$. For details, please refer to [Chapter 7.3](#).

5.1 Electrical Characteristics Internal Supply / DEN Pin

Electrical Characteristics Internal Supply / DEN pin

Unless otherwise specified: $V_{\text{S}} = 5.5 \text{ V to } 40 \text{ V}$, $T_{\text{j}} = -40 \text{ }^{\circ}\text{C to } +150 \text{ }^{\circ}\text{C}$, $R_{\text{SET}} = 12 \text{ k}\Omega$ all voltages with respect to ground, positive current flowing into pin for input pins (I), positive currents flowing out of the I/O and output pins (O) (unless otherwise specified)

Pos.	Parameter	Symbol	Limit Values			Unit	Conditions
			Min.	Typ.	Max.		
5.1.1	Current consumption, active mode	$I_{\text{S}(\text{on})}$	–	–	1.9	mA	¹⁾ $I_{\text{IN_SET}} = 0 \mu\text{A}$ $T_{\text{j}} < 105 \text{ }^{\circ}\text{C}$ $V_{\text{S}} = 18 \text{ V}$ $V_{\text{OUTx}} = 3.6\text{V}$
5.1.2	Current consumption, device disabled via ST	$I_{\text{S}(\text{dis,ST})}$	–	–	1.7	mA	¹⁾ $V_{\text{S}} = 18 \text{ V}$ $T_{\text{j}} < 105 \text{ }^{\circ}\text{C}$ $V_{\text{ST}} = 5 \text{ V}$
5.1.3	Current consumption, device disabled via IN_SET	$I_{\text{S}(\text{dis,IN_SET})}$	–	–	1.7	mA	¹⁾ $V_{\text{S}} = 18 \text{ V}$ $T_{\text{j}} < 105 \text{ }^{\circ}\text{C}$ $V_{\text{IN_SET}} = 5 \text{ V}$
5.1.4	Current consumption, active mode in single fault detection condition with ST-pin unconnected	$I_{\text{S}(\text{fault,STu})}$	–	–	2.1	mA	¹⁾ $V_{\text{S}} = 18 \text{ V}$ $T_{\text{j}} < 105 \text{ }^{\circ}\text{C}$ $R_{\text{SET}} = 12 \text{ k}\Omega$ $V_{\text{OUTx}} = 18 \text{ V or } 0 \text{ V}$
5.1.5	Current consumption, active mode in single fault detection condition with ST-pin connected to GND	$I_{\text{S}(\text{fault,STG})}$	–	–	6.2	mA	¹⁾ $V_{\text{S}} = 18 \text{ V}$ $T_{\text{j}} < 105 \text{ }^{\circ}\text{C}$ $R_{\text{SET}} = 12 \text{ k}\Omega$ $V_{\text{OUTx}} = 18 \text{ V or } 0 \text{ V}$ $V_{\text{ST}} = 0 \text{ V}$

Electrical Characteristics Internal Supply / DEN pin (cont'd)

Unless otherwise specified: $V_S = 5.5 \text{ V to } 40 \text{ V}$, $T_j = -40 \text{ }^\circ\text{C to } +150 \text{ }^\circ\text{C}$, $R_{SET} = 12 \text{ k}\Omega$ all voltages with respect to ground, positive current flowing into pin for input pins (I), positive currents flowing out of the I/O and output pins (O) (unless otherwise specified)

Pos.	Parameter	Symbol	Limit Values			Unit	Conditions
			Min.	Typ.	Max.		
5.1.6	Power-on reset delay time ²⁾	t_{POR}	–	–	25	μs	³⁾ $V_S = 0 \rightarrow 13.5 \text{ V}$ $V_{OUTx(nom)} = 3.6 \pm 0.3\text{V}$ $I_{OUTx} = 80\% I_{OUTx(nom)}$
5.1.7	Required supply voltage for current control	$V_{S(CC)}$	–	–	5.5	V	$V_{OUTx} = 3.6 \text{ V}$ $I_{OUTx} \geq 90\% I_{OUTx(nom)}$
5.1.8	DEN high input current	$I_{DEN(H)}$	–	–	0.1	mA	$T_j < 105 \text{ }^\circ\text{C}$ $V_S = 13.5 \text{ V}, V_{DEN} = 5.5 \text{ V}$ $V_S = 18 \text{ V}, V_{DEN} = 5.5 \text{ V}$ $V_S = 18 \text{ V}, V_{DEN} = 12 \text{ V}$ $V_S = V_{DEN} = 18 \text{ V}$
			–	–	0.1		
			–	–	0.2		
			–	–	0.4		
5.1.9	DEN activation threshold (diagnosis enabled above $V_{DEN(act)}$)	$V_{DEN(act)}$	2.45	–	3.2	V	$V_S = 8...18 \text{ V}$
5.1.10	DEN deactivation threshold (diagnosis disabled below $V_{DEN(dis)}$)	$V_{DEN(dis)}$	1.5	–	2.3	V	$V_S = 8...18 \text{ V}$

- 1) The total device current consumption is the sum of the currents I_S and $I_{DEN(H)}$, please refer to [Pos. 5.1.8](#)
- 2) See also [Figure 4](#)
- 3) Not subject to production test, specified by design

6 IN_SET Pin

The IN_SET pin is a multiple function pin for output current definition, input and diagnostics:

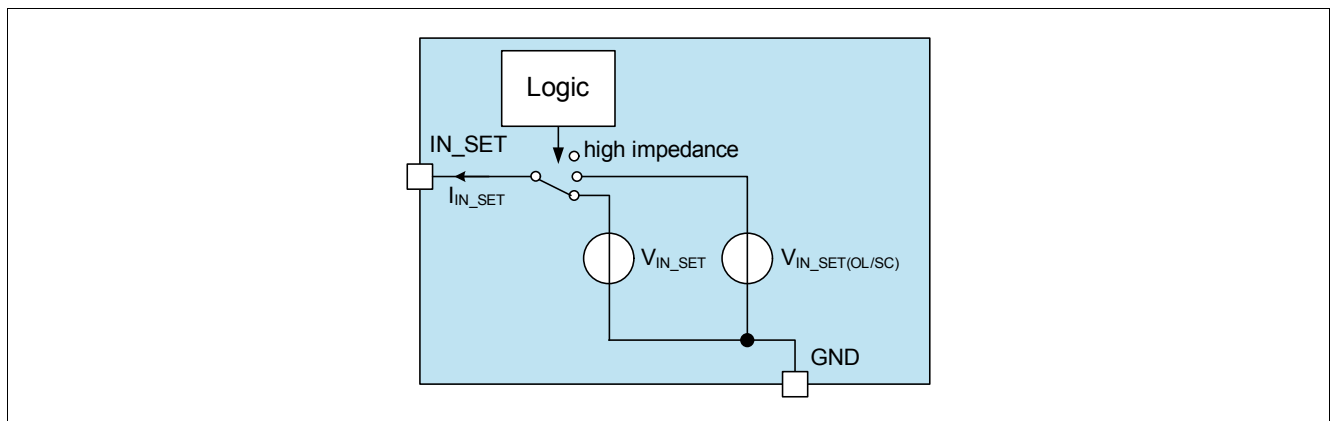

Figure 6 Block Diagram IN_SET pin

6.1 Output Current Adjustment via RSET

The output current for all three channels can only be adjusted simultaneously. The current adjustment can be done by placing a low power resistor (R_{SET}) at the IN_SET pin to ground. The dimensioning of the resistor can be done using the formula below:

$$R_{SET} = \frac{k}{I_{OUT}} \quad (2)$$

The gain factor k (R_{SET} * output current) is specified in [Pos. 9.2.4](#) and [Pos. 9.2.5](#). The current through the R_{SET} is defined by the resistor itself and the reference voltage $V_{IN_SET(ref)}$, which is applied to the IN_SET during supplied device.

6.2 Smart Input Pin

The IN_SET pin can be connected via R_{SET} to the open-drain output of a μC or to an external NMOS transistor as described in [Figure 7](#). This signal can be used to turn off the output stages of the IC. A minimum IN_SET current of $I_{IN_SET(act)}$ is required to turn on the output stages. This feature is implemented to prevent glimming of LEDs caused by leakage currents on the IN_SET pin, see [Figure 10](#) for details. In addition, the IN_SET pin offers the diagnostic feedback information, if the status pin is connected to GND and $V_{DEN} > V_{DEN(act)}$ (refer to [Chapter 5](#)). Another diagnostic possibility is shown in [Figure 8](#), where the diagnosis information is provided via the ST pin (refer to [Chapter 7](#) and [Chapter 8](#)) to a micro controller. In case of a fault event with the ST pin connected to GND the IN_SET voltage is increased to $V_{IN_SET(OL/SC)}$ [Pos. 8.3.2](#). Therefore, the device has two voltage domains at the IN_SET-pin, which is shown in [Figure 11](#).

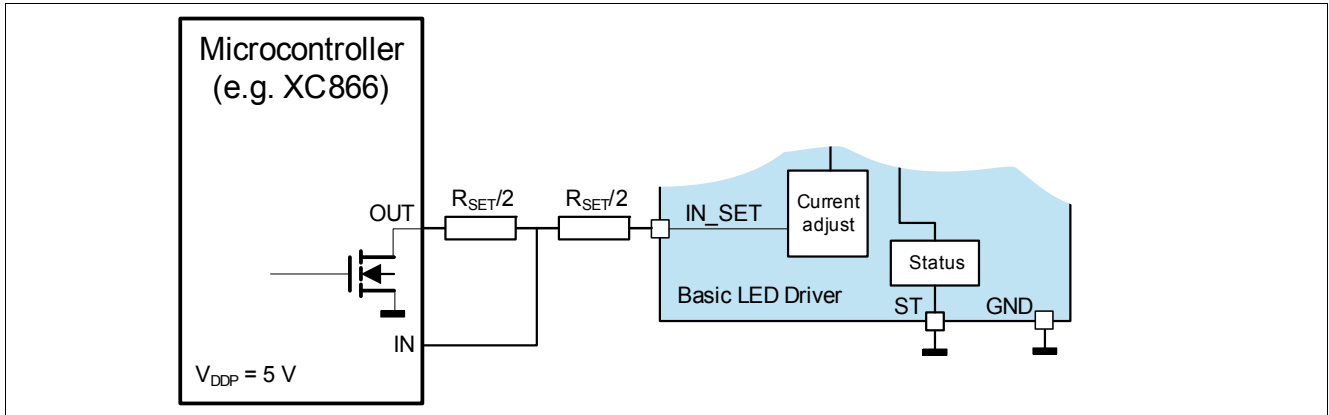

Figure 7 Schematics IN_SET interface to μ C, diagnosis via IN_SET pin

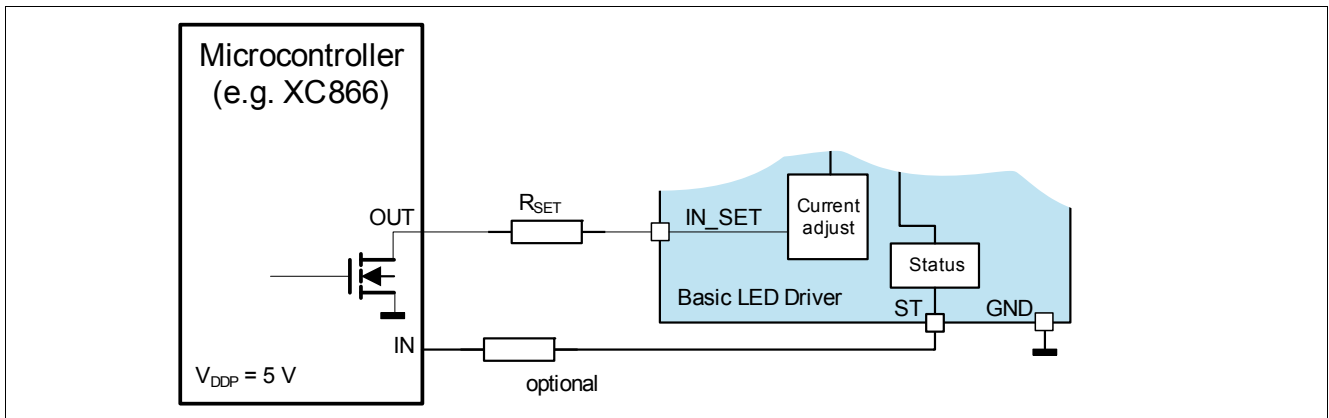

Figure 8 Schematics IN_SET interface to μ C, diagnosis via ST pin

The resulting switching times are shown in [Figure 9](#):

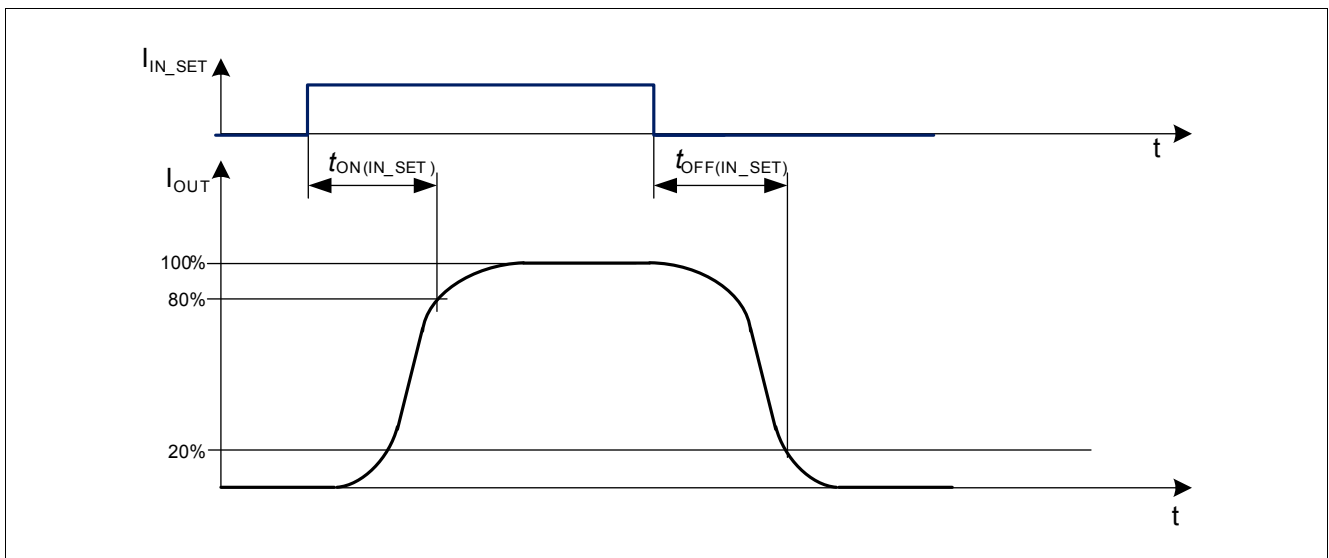

Figure 9 Switching times via IN_SET

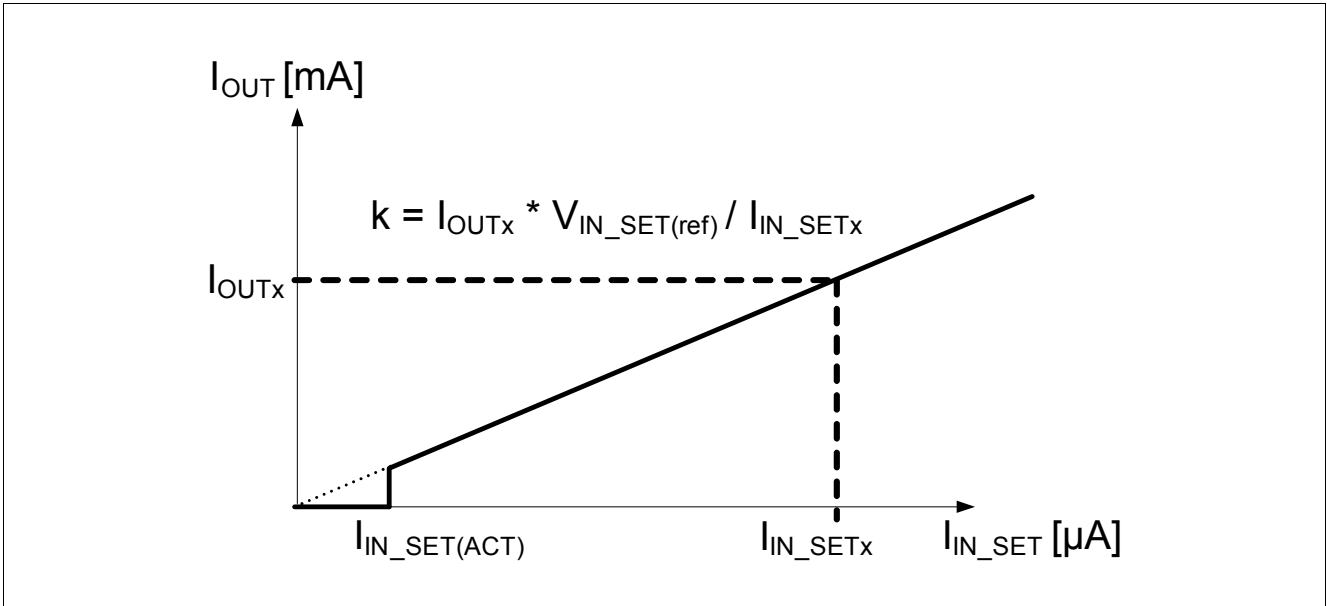

Figure 10 I_{OUT} versus I_{IN_SET}

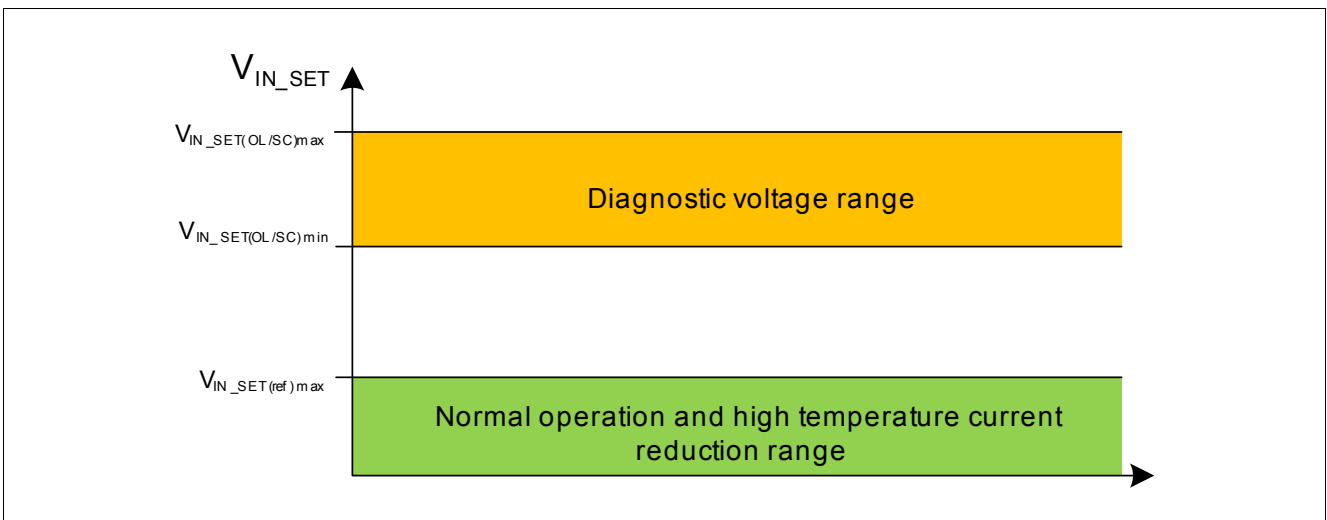

Figure 11 Voltage domains for IN_SET pin, if ST pin is connected to GND

7 ST Pin

The ST pin is a multiple function pin.

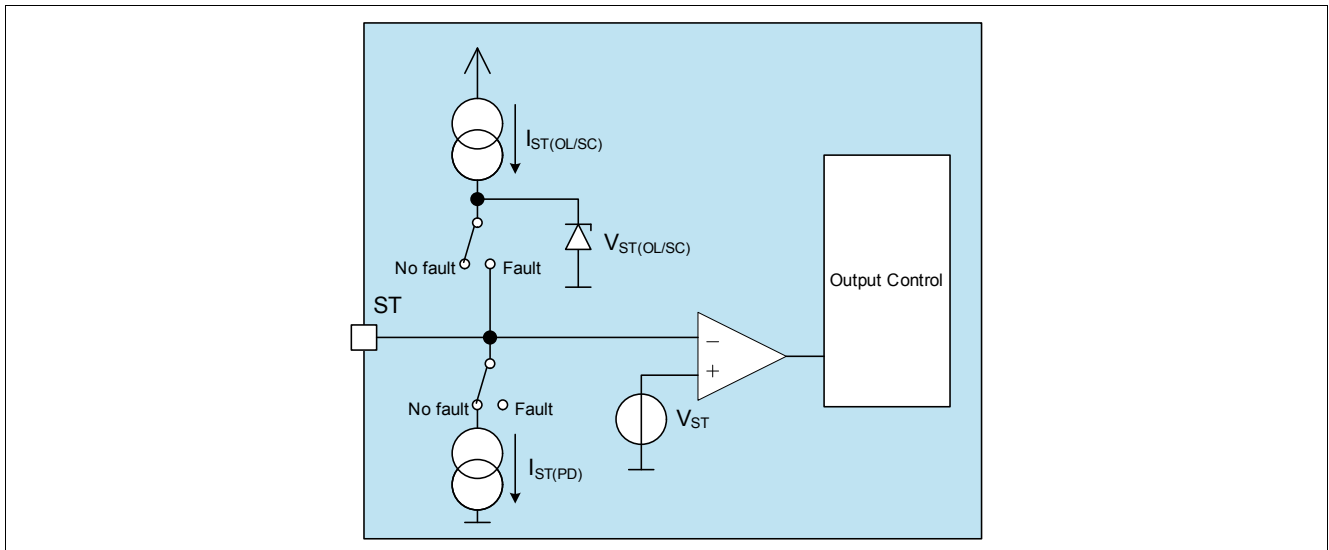

Figure 12 Block Diagram ST pin

7.1 Diagnosis Selector

If the voltage at the DEN pin V_{DEN} is higher than $V_{DEN(Act)}$, the diagnosis is activated. For details, please refer to [Chapter 5](#). If the status pin is unconnected or connected to GND via a high ohmic resistor (V_{ST} to be below $V_{ST(L)}$), the ST pin acts as diagnosis output pin. In normal operation (device is activated) the ST pin is pulled to GND via the internal pull down current $I_{ST(PD)}$. In case of an open load or short circuit to GND condition the ST pin is switched to $V_{ST(OL/SC)}$ after the open load or short circuit detection filter time ([Pos. 8.3.9](#), [Pos. 8.3.12](#)).

If the device is operated in PWM operation via the VS pin the ST pin should be connected to GND via a high ohmic resistor (e.g. 470k Ω) to ensure proper device behavior during fast rising VS slope.

If the ST pin is shorted to GND the diagnostic feedback is performed via the IN_SET-pin, which is shown in [Chapter 6.2](#) and [Chapter 8](#).

7.2 Diagnosis Output

If the status pin is unconnected or connected to GND via a high ohmic resistor (V_{ST} to be below $V_{ST(L)}$), it acts as a diagnostic output, if the voltage at the DEN pin is above $V_{DEN(Act)}$. In case of a fault condition the ST pin rises its voltage to $V_{ST(OL/SC)}$ ([Pos. 8.3.7](#)). Details are shown in [Chapter 8](#).

7.3 Disable Input

If an external voltage higher than $V_{ST(H)}$ ([Pos. 8.3.5](#)) is applied to the ST pin, the device is switched off. This function is working independently of the voltage at the DEN pin. Even if the diagnosis is disabled via $V_{DEN} < V_{DEN(dis)}$ the disable function of the ST pin is working. This function is used for applications, where multiple drivers should be used for one light function. It is possible to combine the drivers' fault diagnosis via the ST pins. If a single LED chain fails, the entire light function is switched off. In this scenario e.g. the diagnostic circuit on the body control module can easily distinguish between the two cases (normal load or load fault), because nearly no current is flowing into the LED module during the fault scenario - the drivers consume a current of $I_{S(fault,STu)}$ ([Pos. 5.1.4](#)) or $I_{S(dis,ST)}$ ([Pos. 5.1.2](#)).

As soon as one LED chain fails, the ST-pin of this device is switched to $V_{ST(OL/SC)}$. The other devices used for the same light function can be connected together via the ST pins. This leads to a switch off of all devices connected together. Application examples are shown in [Chapter 10](#).

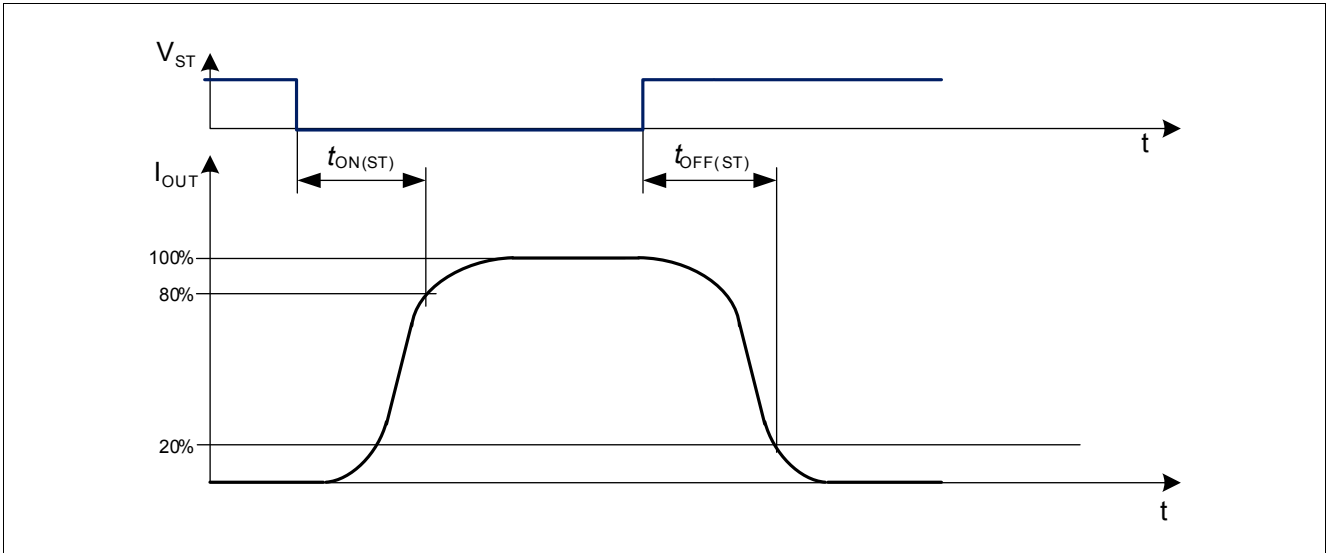

Figure 13 Switching times via ST Pin

8 Load Diagnosis

The diagnosis function is enabled, if the voltage at the DEN pin V_{DEN} is above $V_{DEN(Act)}$ as described in [Chapter 5](#).

8.1 Open Load

An open load diagnosis feature is integrated in the TLD1314EL driver IC. If there is an open load on one of the outputs, the outputs are turned off. The potential on the IN_SET pin rises up to $V_{IN_SET(OL/SC)}$, if the ST is connected to GND. This high voltage can be used as input signal for a μC as shown in [Figure 8](#). If the ST pin is open or connected to GND via a high ohmic resistor, the ST pin rises to a high potential as described in [Chapter 7](#). More details are shown in [Figure 17](#). The open load status is not latched, as soon as the open load condition is no longer present, the output stage will be turned on again. An open load condition is detected, if the voltage drop over the output stage V_{PS} is below the threshold according [Pos. 8.3.10](#) and a filter time of t_{OL} is passed.

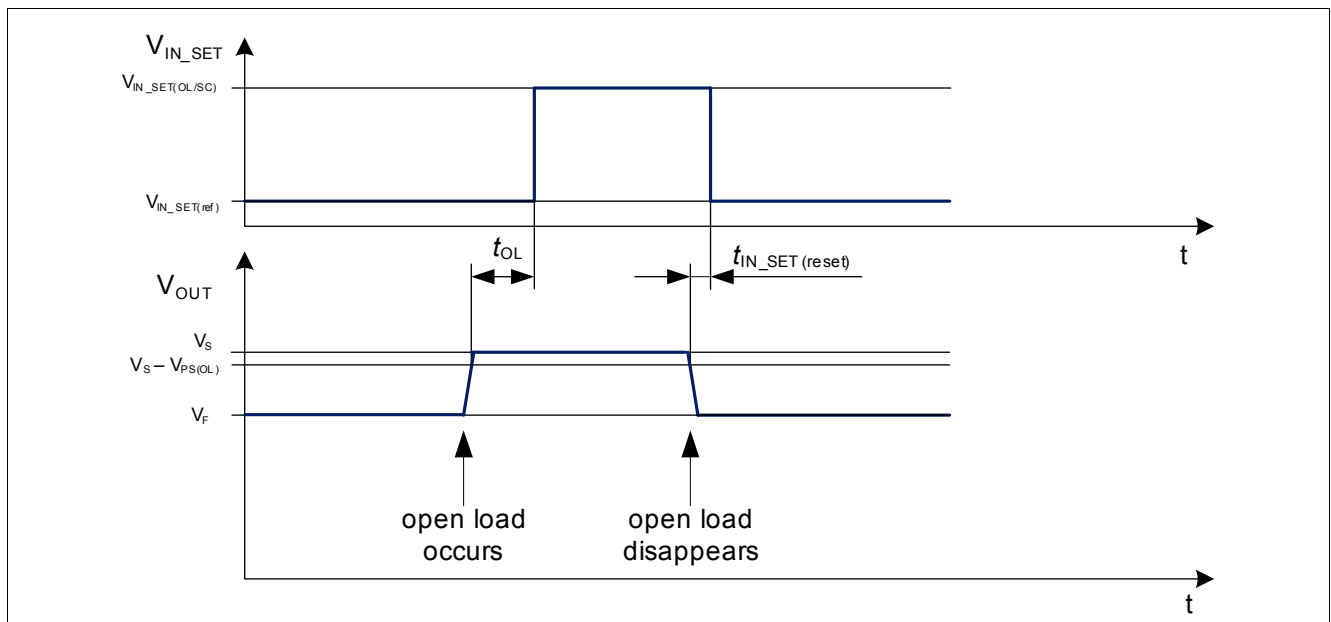

Figure 14 IN_SET behavior during open load condition with ST pin connected to GND and $V_{DEN} > V_{DEN(Act)}$

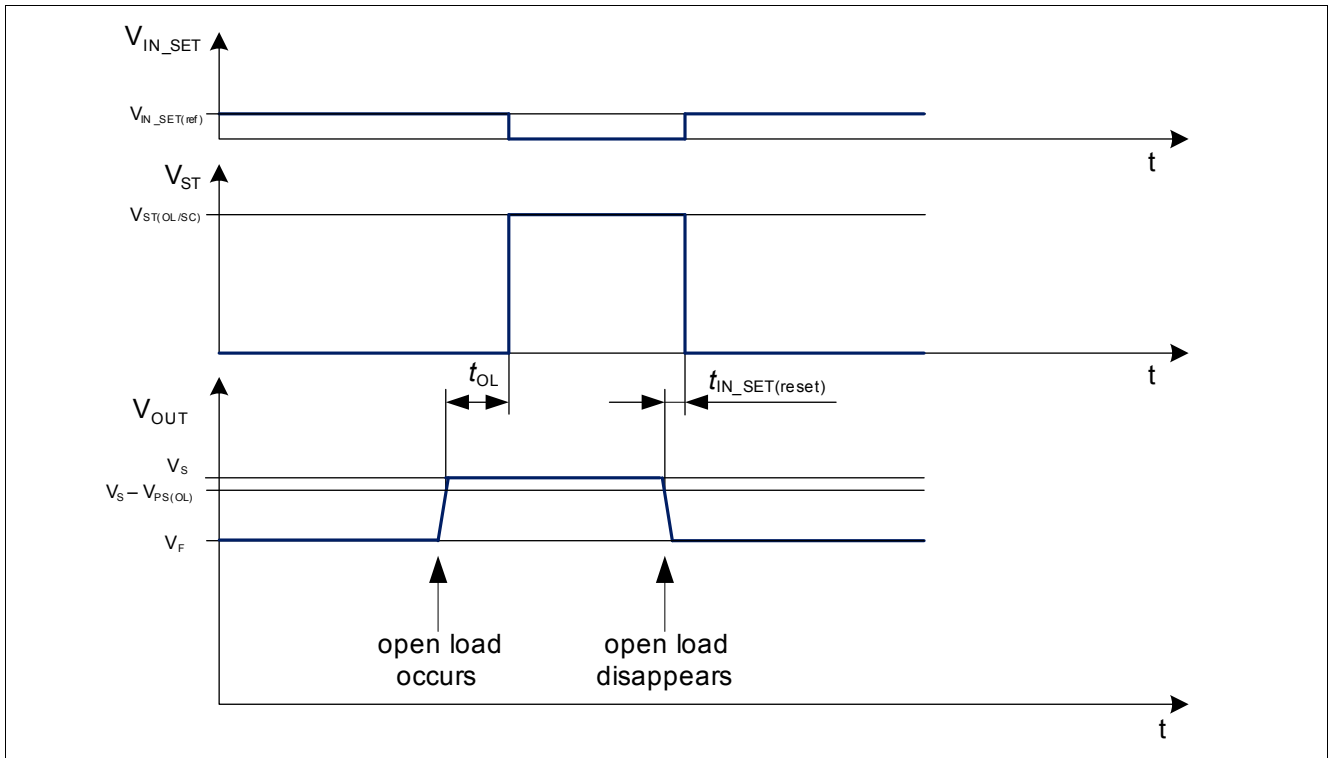

Figure 15 IN_SET and ST behavior during open load condition (ST unconnected) and $V_{DEN} > V_{DEN(act)}$

8.2 Short Circuit to GND detection

The TLD1314EL has an integrated SC to GND detection. If the output stage is turned on and the voltage at the output falls below $V_{OUT(SC)}$ the potential on the IN_SET pin is increased up to $V_{IN_SET(OL/SC)}$ after t_{SC} , if the ST pin is connected to GND. If the ST is open or connected to GND via a high ohmic resistor the fault is indicated on the ST pin according to [Chapter 7](#) after t_{SC} . More details are shown in [Figure 17](#). This condition is not latched. For detecting a normal condition after a short circuit detection an output current according to $I_{OUT(SC)}$ is driven by the channel.

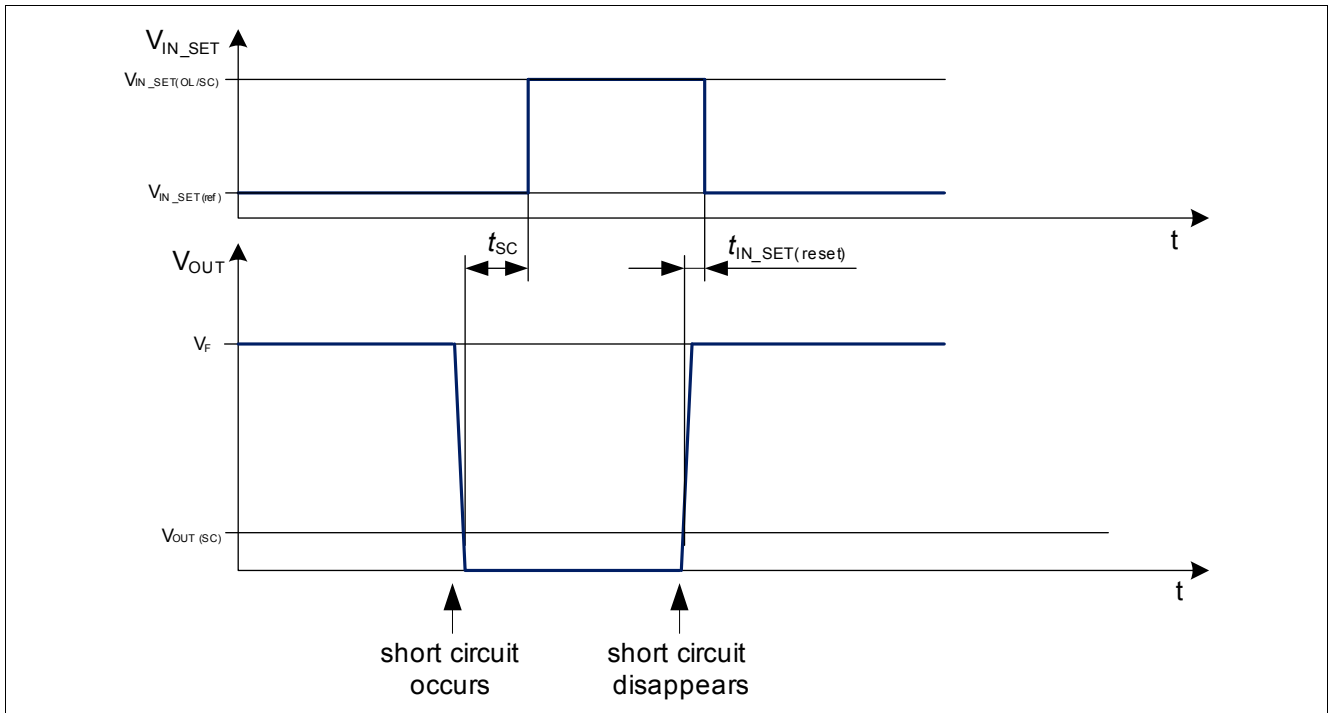

Figure 16 **IN_SET** behavior during short circuit to GND condition with ST connected to GND and $V_{DEN} > V_{DEN(act)}$

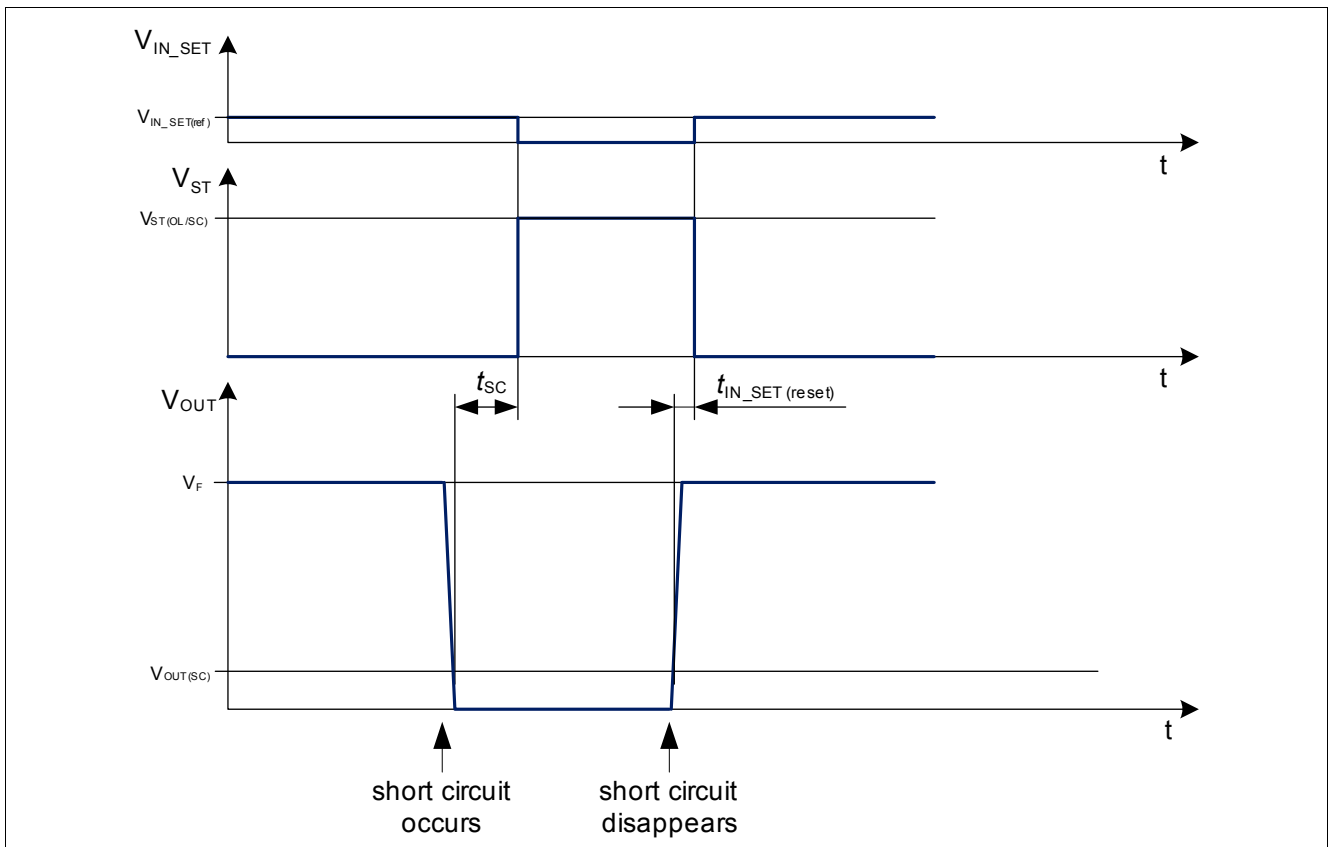

Figure 17 **IN_SET** and **ST** behavior during short circuit to GND condition (ST unconnected) and $V_{DEN} > V_{DEN(act)}$

Note: In applications, where 1 output of the LITIX™ Basic IC is not used, a zener diode can be connected to the output to avoid unintended open load or short circuit conditions. The zener voltage should be in the range of the LEDs' forward voltage.

8.3 Electrical Characteristics IN_SET Pin and Load Diagnosis

Electrical Characteristics IN_SET pin and Load Diagnosis

Unless otherwise specified: $V_S = 5.5 \text{ V to } 40 \text{ V}$, $T_j = -40 \text{ °C to } +150 \text{ °C}$, $R_{SET} = 12 \text{ k}\Omega$, $V_{DEN} = 5.5 \text{ V}$, all voltages with respect to ground, positive current flowing into pin for input pins (I), positive currents flowing out of the I/O and output pins (O) (unless otherwise specified)

Pos.	Parameter	Symbol	Limit Values			Unit	Conditions
			Min.	Typ.	Max.		
8.3.1	IN_SET reference voltage	$V_{IN_SET(ref)}$	1.19	1.23	1.27	V	¹⁾ $V_{OUTx} = 3.6 \text{ V}$ $T_j = 25...115 \text{ °C}$
8.3.2	IN_SET open load/short circuit voltage	$V_{IN_SET(OL/SC)}$	4	–	5.5	V	¹⁾ $V_S > 8 \text{ V}$ $T_j = 25...150 \text{ °C}$ $V_S = V_{OUTx} \text{ (OL) or } V_{OUTx} = 0 \text{ V (SC)}$
8.3.3	IN_SET open load/short circuit current	$I_{IN_SET(OL/SC)}$	1.5	–	7.4	mA	¹⁾ $V_S > 8 \text{ V}$ $T_j = 25...150 \text{ °C}$ $V_{IN_SET} = 4 \text{ V}$ $V_S = V_{OUTx} \text{ (OL) or } V_{OUT} = 0 \text{ V (SC)}$
8.3.4	ST device turn on threshold (active low) in case of voltage applied from external (ST-pin acting as input)	$V_{ST(L)}$	0.8	–	–	V	–
8.3.5	ST device turn off threshold (active low) in case of voltage applied from external (ST-pin acting as input)	$V_{ST(H)}$	–	–	2.5	V	–
8.3.6	ST pull down current	$I_{ST(PD)}$	–	–	15	μA	$V_{ST} = 0.8 \text{ V}$
8.3.7	ST open load/short circuit voltage (ST-pin acting as diagnosis output)	$V_{ST(OL/SC)}$	4	–	5.5	V	¹⁾ $V_S > 8 \text{ V}$ $T_j = 25...150 \text{ °C}$ $R_{ST} = 470 \text{ k}\Omega$ $V_S = V_{OUTx} \text{ (OL) or } V_{OUT} = 0 \text{ V (SC)}$
8.3.8	ST open load/short circuit current (ST-pin acting as diagnosis output)	$I_{ST(OL/SC)}$	100	–	220	μA	¹⁾ $V_S > 8 \text{ V}$ $T_j = 25...150 \text{ °C}$ $V_{ST} = 2.5 \text{ V}$ $V_S = V_{OUTx} \text{ (OL) or } V_{OUT} = 0 \text{ V (SC)}$
8.3.9	OL detection filter time	t_{OL}	10	22	35	μs	¹⁾ $V_S > 8 \text{ V}$
8.3.10	OL detection voltage $V_{PS(OL)} = V_S - V_{OUTx}$	$V_{PS(OL)}$	0.2	–	0.4	V	$V_S > 8 \text{ V}$

Electrical Characteristics IN_SET pin and Load Diagnosis (cont'd)

Unless otherwise specified: $V_S = 5.5 \text{ V to } 40 \text{ V}$, $T_j = -40 \text{ }^\circ\text{C to } +150 \text{ }^\circ\text{C}$, $R_{SET} = 12 \text{ k}\Omega$, $V_{DEN} = 5.5 \text{ V}$, all voltages with respect to ground, positive current flowing into pin for input pins (I), positive currents flowing out of the I/O and output pins (O) (unless otherwise specified)

Pos.	Parameter	Symbol	Limit Values			Unit	Conditions
			Min.	Typ.	Max.		
8.3.11	Short circuit to GND detection threshold	$V_{OUT(SC)}$	0.8	–	1.4	V	$V_S > 8 \text{ V}$
8.3.12	SC detection filter time	t_{SC}	10	22	35	μs	¹⁾ $V_S > 8 \text{ V}$
8.3.13	IN_SET diagnosis reset time	$t_{IN_SET(reset)}$	–	5	20	μs	¹⁾ $V_S > 8 \text{ V}$
8.3.14	SC detection current in case of unconnected ST-pin	$I_{OUT(SC,STu)}$	100	200	300	μA	$V_S > 8 \text{ V}$ $V_{OUTx} = 0 \text{ V}$
8.3.15	SC detection current in case of ST-pin shorted to GND	$I_{OUT(SC,STG)}$	0.1	2	4.75	mA	$V_S > 8 \text{ V}$ $V_{OUTx} = 0 \text{ V}$ $V_{ST} = 0 \text{ V}$
8.3.16	IN_SET activation current without turn on of output stages	$I_{IN_SET(act)}$	2	–	15	μA	See Figure 10

1) Not subject to production test, specified by design

9 Power Stage

The output stages are realized as high side current sources with a current of 120 mA. During off state the leakage current at the output stage is minimized in order to prevent a slightly glowing LED.

The maximum current of each channel is limited by the power dissipation and used PCB cooling areas (which results in the applications R_{thJA}).

For an operating current control loop the supply and output voltages according to the following parameters have to be considered:

- Required supply voltage for current control $V_{S(CC)}$, **Pos. 5.1.7**
- Voltage drop over output stage during current control $V_{PS(CC)}$, **Pos. 9.2.6**
- Required output voltage for current control $V_{OUTx(CC)}$, **Pos. 9.2.7**

9.1 Protection

The device provides embedded protective functions, which are designed to prevent IC destruction under fault conditions described in this data sheet. Fault conditions are considered as “outside” normal operating range. Protective functions are neither designed for continuous nor for repetitive operation.

9.1.1 Over Load Behavior

An over load detection circuit is integrated in the LITIX™ Basic IC. It is realized by a temperature monitoring of the output stages (OUTx).

As soon as the junction temperature exceeds the current reduction temperature threshold $T_{j(CRT)}$ the output current will be reduced by the device by reducing the IN_SET reference voltage $V_{IN_SET(ref)}$. This feature avoids LED's flickering during static output overload conditions. Furthermore, it protects LEDs against over temperature, which are mounted thermally close to the device. If the device temperature still increases, the three output currents decrease close to 0 A. As soon as the device cools down the output currents rise again.

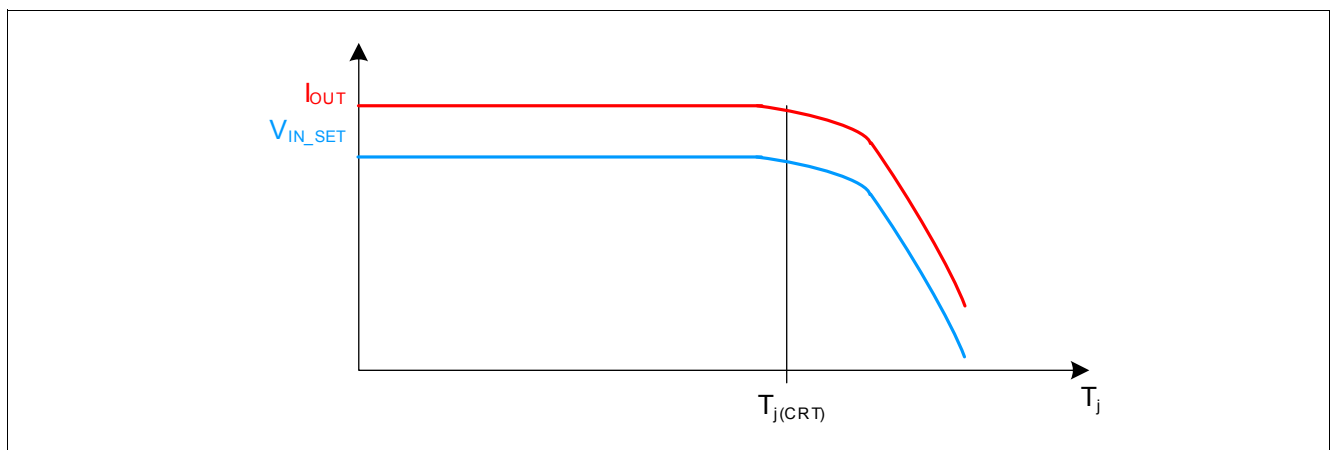

Figure 18 Output current reduction at high temperature

Note: This high temperature output current reduction is realized by reducing the IN_SET reference voltage (Pos. 8.3.1). In case of very high power loss applied to the device and very high junction temperature the output current may drop down to $I_{OUTx} = 0$ mA, after a slight cooling down the current increases again.

9.1.2 Reverse Battery Protection

The TLD1314EL has an integrated reverse battery protection feature. This feature protects the driver IC itself, but also connected LEDs. The output reverse current is limited to $I_{OUTx(rev)}$ by the reverse battery protection.

Note: Due to the reverse battery protection a reverse protection diode for the light module may be obsolete. In case of high ISO-pulse requirements and only minor protecting components like capacitors a reverse protection diode may be reasonable. The external protection circuit needs to be verified in the application.

9.2 Electrical Characteristics Power Stage

Electrical Characteristics Power Stage

Unless otherwise specified: $V_S = 5.5 \text{ V to } 18 \text{ V}$, $T_j = -40 \text{ }^\circ\text{C to } +150 \text{ }^\circ\text{C}$, $V_{OUTx} = 3.6 \text{ V}$, all voltages with respect to ground, positive current flowing into pin for input pins (I), positive currents flowing out of the I/O and output pins (O) (unless otherwise specified)

Pos.	Parameter	Symbol	Limit Values			Unit	Conditions
			Min.	Typ.	Max.		
9.2.1	Output leakage current	$I_{OUTx(Leak)}$	-	-	7 3	μA	$I_{IN_SET} = 0 \mu\text{A}$ $V_{OUTx} = 2.5 \text{ V}$ $T_j = 150 \text{ }^\circ\text{C}$ ¹⁾ $T_j = 85 \text{ }^\circ\text{C}$
9.2.2	Output leakage current in boost over battery setup	- $I_{OUTx(Leak,B2B)}$	-	-	50	μA	¹⁾ $I_{IN_SET} = 0 \mu\text{A}$ $V_{OUTx} = V_S = 40 \text{ V}$
9.2.3	Reverse output current	$-I_{OUTx(rev)}$	-	-	1	μA	¹⁾ $V_S = -16 \text{ V}$ Output load: LED with break down voltage < - 0.6 V
9.2.4	Output current accuracy limited temperature range	k_{LT}	697 645	750 750	803 855		¹⁾ $T_j = 25...115 \text{ }^\circ\text{C}$ $V_S = 8...18 \text{ V}$ $V_{PS} = 2 \text{ V}$ $R_{SET} = 6...12 \text{ k}\Omega$ $R_{SET} = 30 \text{ k}\Omega$
9.2.5	Output current accuracy over temperature	k_{ALL}	697 645	750 750	803 855		¹⁾ $T_j = -40...115 \text{ }^\circ\text{C}$ $V_S = 8...18 \text{ V}$ $V_{PS} = 2 \text{ V}$ $R_{SET} = 6...12 \text{ k}\Omega$ $R_{SET} = 30 \text{ k}\Omega$
9.2.6	Voltage drop over power stage during current control $V_{PS(CC)} = V_S - V_{OUTx}$	$V_{PS(CC)}$	0.75	-	-	V	¹⁾ $V_S = 13.5 \text{ V}$ $R_{SET} = 12 \text{ k}\Omega$ $I_{OUTx} \geq 90\%$ of $(k_{LT(typ)}/R_{SET})$
9.2.7	Required output voltage for current control	$V_{OUTx(CC)}$	2.3	-	-	V	¹⁾ $V_S = 13.5 \text{ V}$ $R_{SET} = 12 \text{ k}\Omega$ $I_{OUTx} \geq 90\%$ of $(k_{LT(typ)}/R_{SET})$
9.2.8	Maximum output current	$I_{OUT(max)}$	120	-	-	mA	$R_{SET} = 4.7 \text{ k}\Omega$ The maximum output current is limited by the thermal conditions. Please refer to Pos. 4.3.1 - Pos. 4.3.3

Electrical Characteristics Power Stage (cont'd)

Unless otherwise specified: $V_S = 5.5 \text{ V to } 18 \text{ V}$, $T_j = -40 \text{ }^\circ\text{C to } +150 \text{ }^\circ\text{C}$, $V_{\text{OUTx}} = 3.6 \text{ V}$, all voltages with respect to ground, positive current flowing into pin for input pins (I), positive currents flowing out of the I/O and output pins (O) (unless otherwise specified)

Pos.	Parameter	Symbol	Limit Values			Unit	Conditions
			Min.	Typ.	Max.		
9.2.9	ST turn on time	$t_{\text{ON(ST)}}$	–	–	15	μs	²⁾ $V_S = 13.5 \text{ V}$ $R_{\text{SET}} = 12 \text{ k}\Omega$ ST \rightarrow L $I_{\text{OUTx}} = 80\%$ of $(k_{\text{LT(typ)}}/R_{\text{SET}})$
9.2.10	ST turn off time	$t_{\text{OFF(ST)}}$	–	–	10	μs	²⁾ $V_S = 13.5 \text{ V}$ $R_{\text{SET}} = 12 \text{ k}\Omega$ ST \rightarrow H $I_{\text{OUTx}} = 20\%$ of $(k_{\text{LT(typ)}}/R_{\text{SET}})$
9.2.11	IN_SET turn on time	$t_{\text{ON(IN_SET)}}$	–	–	15	μs	$V_S = 13.5 \text{ V}$ $I_{\text{IN_SET}} = 0 \rightarrow 100 \mu\text{A}$ $I_{\text{OUTx}} = 80\%$ of $(k_{\text{LT(typ)}}/R_{\text{SET}})$
9.2.12	IN_SET turn off time	$t_{\text{OFF(IN_SET)}}$	–	–	10	μs	$V_S = 13.5 \text{ V}$ $I_{\text{IN_SET}} = 100 \rightarrow 0 \mu\text{A}$ $I_{\text{OUTx}} = 20\%$ of $(k_{\text{LT(typ)}}/R_{\text{SET}})$
9.2.13	Current reduction temperature threshold	$T_{\text{j(CRT)}}$	–	140	–	$^\circ\text{C}$	¹⁾ $I_{\text{OUTx}} = 95\%$ of $(k_{\text{LT(typ)}}/R_{\text{SET}})$
9.2.14	Output current during current reduction at high temperature	$I_{\text{OUT(CRT)}}$	85% of $(k_{\text{LT(typ)}}/R_{\text{SET}})$	–	–	A	¹⁾ $R_{\text{SET}} = 12 \text{ k}\Omega$ $T_j = 150 \text{ }^\circ\text{C}$

1) Not subject to production test, specified by design

2) see also [Figure 13](#)

10 Application Information

Note: The following information is given as a hint for the implementation of the device only and shall not be regarded as a description or warranty of a certain functionality, condition or quality of the device.

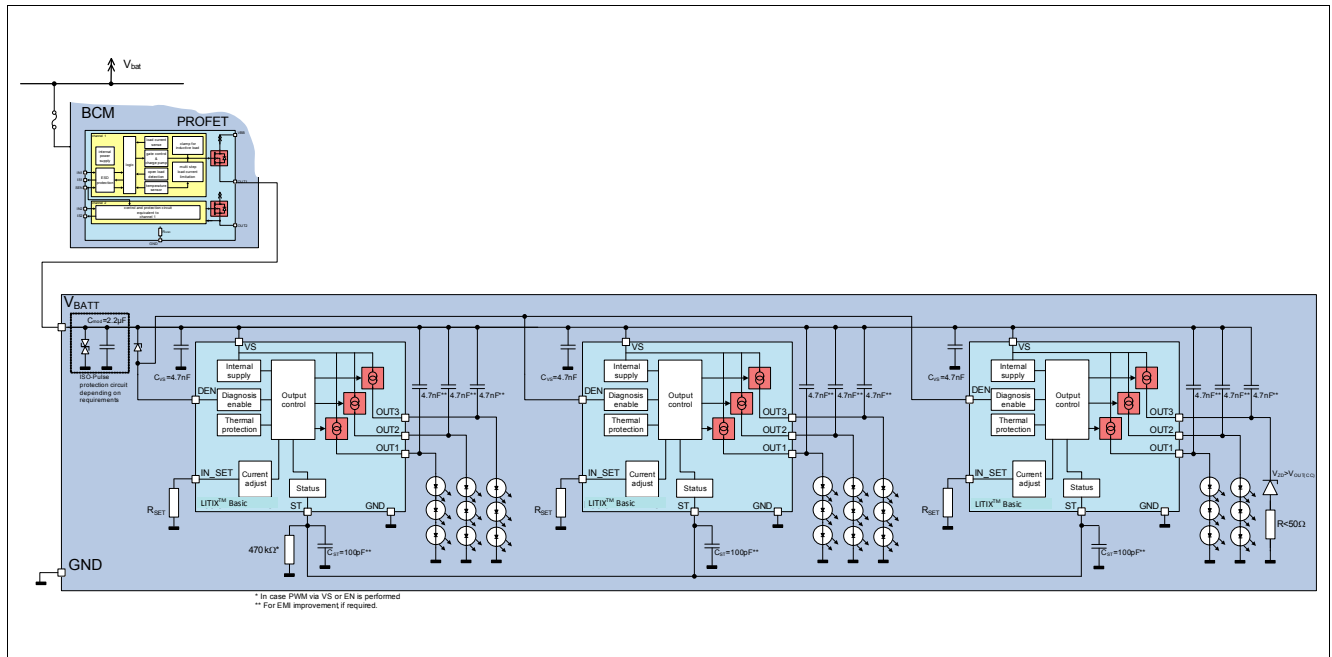

Figure 19 System Diagram TLD1314EL in combination with multiple devices and two channel usage for device at the right side

Note: This is a very simplified example of an application circuit. In case of high ISO-pulse requirements a reverse protection diode may be used for LED protection. The function must be verified in the real application.

10.1 Further Application Information

- For further information you may contact <http://www.infineon.com/>

11 Package Outlines

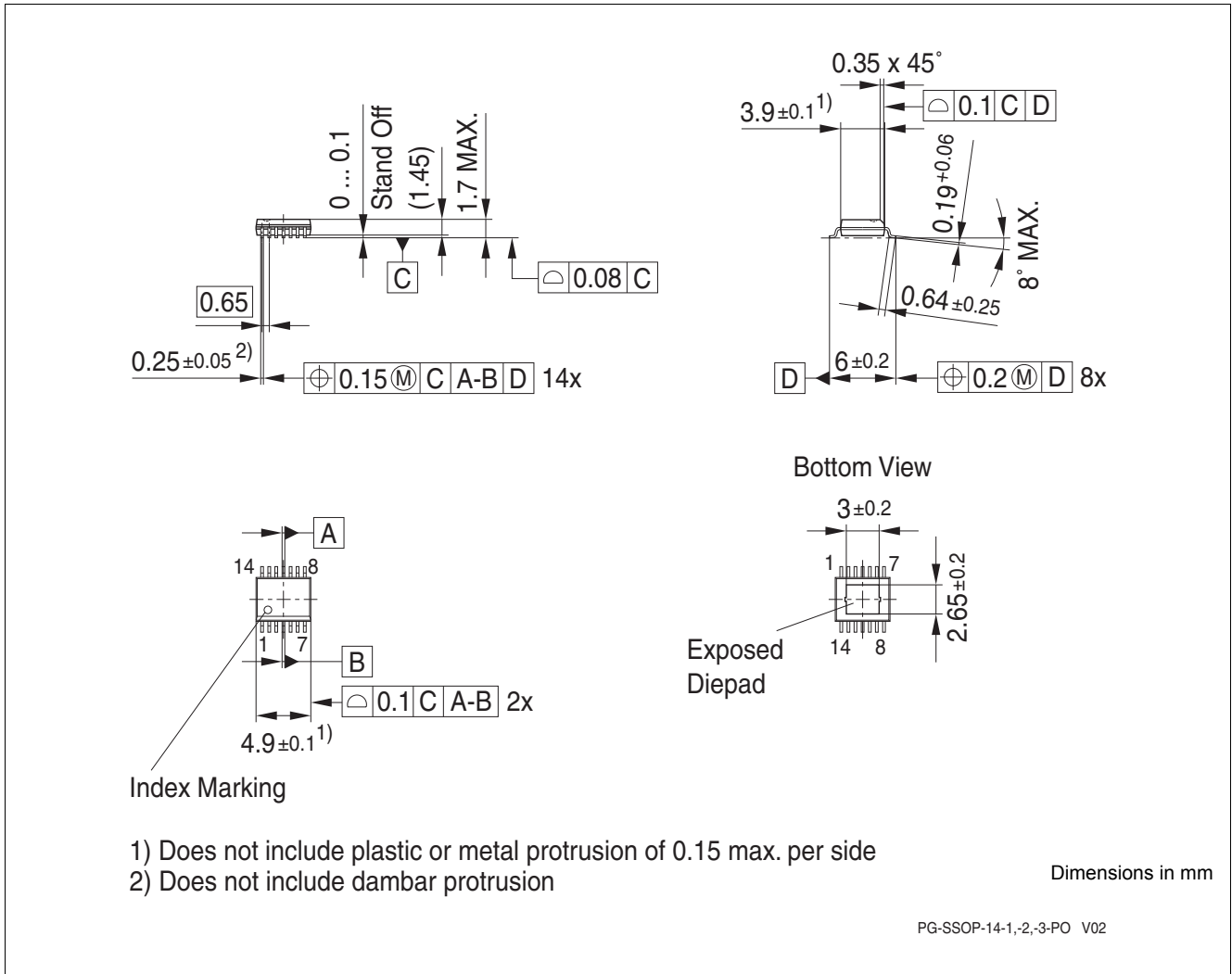

Figure 20 PG-SSOP14

Green Product (RoHS compliant)

To meet the world-wide customer requirements for environmentally friendly products and to be compliant with government regulations the device is available as a green product. Green products are RoHS-Compliant (i.e. Pb-free finish on leads and suitable for Pb-free soldering according to IPC/JEDEC J-STD-020).

For further information on alternative packages, please visit our website:

<http://www.infineon.com/packages>.

12 Revision History

Revision	Date	Changes
1.0	2013-08-08	Initial revision of data sheet
1.1	2015-03-19	Updated parameters K_{LT} and K_{ALL} in the chapter Power Stage.

Edition 2015-03-24

**Published by
Infineon Technologies AG
81726 Munich, Germany**

**© 2015 Infineon Technologies AG
All Rights Reserved.**

Legal Disclaimer

The information given in this document shall in no event be regarded as a guarantee of conditions or characteristics. With respect to any examples or hints given herein, any typical values stated herein and/or any information regarding the application of the device, Infineon Technologies hereby disclaims any and all warranties and liabilities of any kind, including without limitation, warranties of non-infringement of intellectual property rights of any third party.

Information

For further information on technology, delivery terms and conditions and prices, please contact the nearest Infineon Technologies Office (www.infineon.com).

Warnings

Due to technical requirements, components may contain dangerous substances. For information on the types in question, please contact the nearest Infineon Technologies Office.

Infineon Technologies components may be used in life-support devices or systems only with the express written approval of Infineon Technologies, if a failure of such components can reasonably be expected to cause the failure of that life-support device or system or to affect the safety or effectiveness of that device or system. Life support devices or systems are intended to be implanted in the human body or to support and/or maintain and sustain and/or protect human life. If they fail, it is reasonable to assume that the health of the user or other persons may be endangered.