

# TLC5920 16x8 BIT LED DRIVER/CONTROLLER

SLAS264A – MARCH 2000 REVISED SEPTEMBER 2002

- **Drive Capability:**
  - Segment . . . 30 mA × 16 Bits
  - Common . . . 640 mA
- **Constant Current Output . . . 3 mA to 30 mA (Current Value Setting for All Channels Using External Resistor)**
- **Constant Current Accuracy ±6% (Maximum Error Between Bits)**
- **Data Input: Clock Synchronized Serial Input**
- **LED Type Applied Cathode Common**
- **Logic Power Supply Voltage 4.5 V to 5.5 V**
- **LED Power Supply Voltage 4.5 V to 5.5 V**
- **Operating Frequency . . . 10 MHz**
- **Operating Free-Air Temperature Range –20°C to 85°C**
- **48-Pin SSOL Package**

## description

The TLC5920 is an LED driver incorporating a 16-channel shift register, data latch, and constant current circuitry with current value control and 8-channel common driver into a single chip. The constant output current is capable of 30 mA for 16 bits simultaneously, and the current value can be set by one external register. This device also includes a 16-bit segment driver and 8-bit common driver; therefore, the monochrome LED array with 16 × 8 dots can be driven by only one TLC5920, and a two-color LED array with 16 x 16 dots can be driven by two TLC5920s.

DL PACKAGE  
(TOP VIEW)

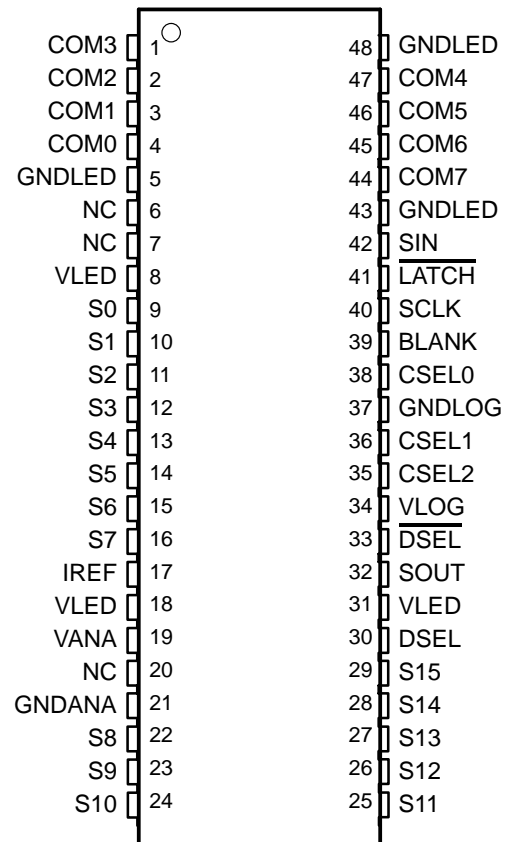

Please be aware that an important notice concerning availability, standard warranty, and use in critical applications of Texas Instruments semiconductor products and disclaimers thereto appears at the end of this data sheet.

PRODUCTION DATA information is current as of publication date. Products conform to specifications per the terms of Texas Instruments standard warranty. Production processing does not necessarily include testing of all parameters.

 **TEXAS  
INSTRUMENTS**

POST OFFICE BOX 655303 • DALLAS, TEXAS 75265

Copyright © 2002, Texas Instruments Incorporated

# TLC5920 16x8 BIT LED DRIVER/CONTROLLER

SLAS264A – MARCH 2000 REVISED SEPTEMBER 2002

## functional block diagram

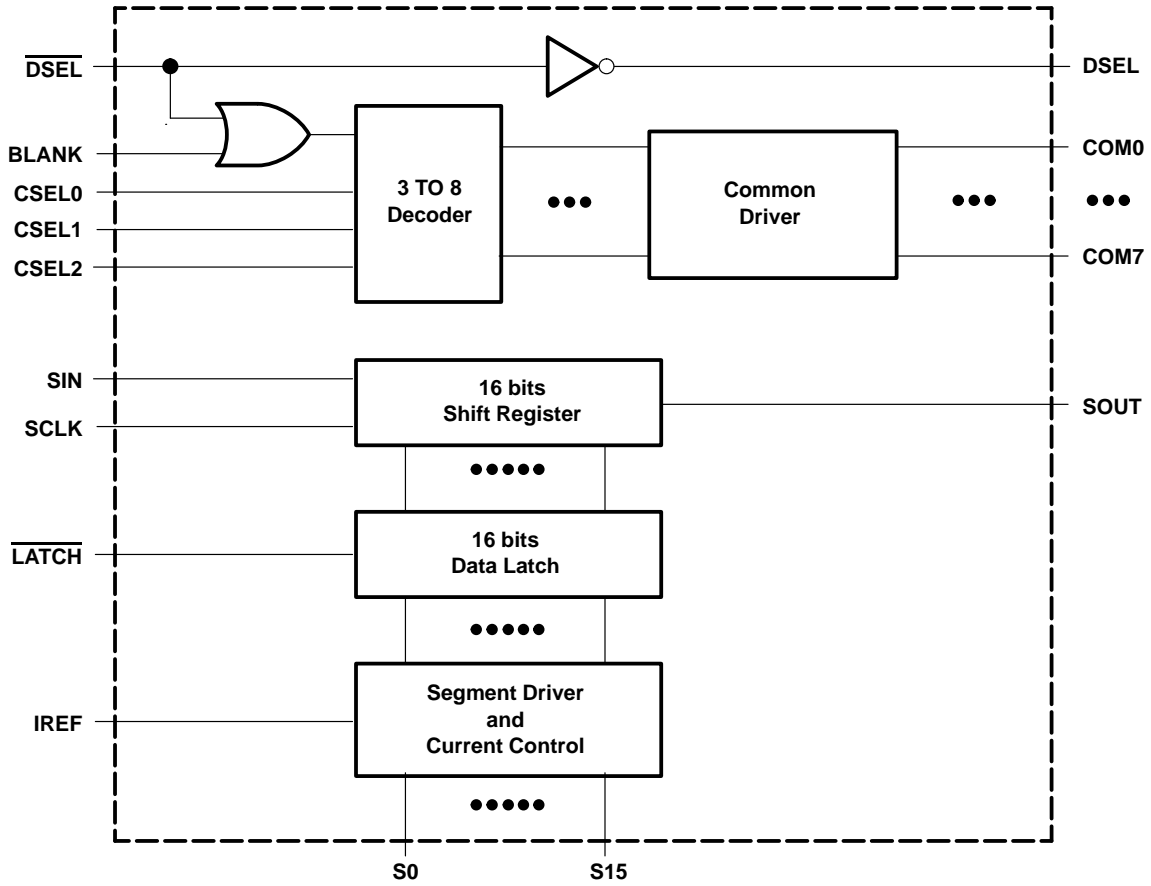

### Terminal Functions

TERMINAL NAME	NO.	I/O	DESCRIPTION																																				
BLANK	39	I	Blank(light off). By turning all the output for the common driver off, the LED is turned off. When BLANK is high, the LED is turned off.																																				
COM0 – COM7	4, 3, 2, 1, 47, 46, 45, 44	O	LED common driver output																																				
CSEL0 – 2	38, 36, 35	I	Common driver select. One terminal out of COM0 through COM7 is selected.  <table style="margin-left: auto; margin-right: auto;"> <tr> <td style="text-align: center;"><b>2</b></td> <td style="text-align: center;"><b>1</b></td> <td style="text-align: center;"><b>0</b></td> <td style="text-align: center;"><b>Common Driver</b></td> </tr> <tr> <td style="text-align: center;">L</td> <td style="text-align: center;">L</td> <td style="text-align: center;">L</td> <td style="text-align: center;">0</td> </tr> <tr> <td style="text-align: center;">L</td> <td style="text-align: center;">L</td> <td style="text-align: center;">H</td> <td style="text-align: center;">1</td> </tr> <tr> <td style="text-align: center;">L</td> <td style="text-align: center;">H</td> <td style="text-align: center;">L</td> <td style="text-align: center;">2</td> </tr> <tr> <td style="text-align: center;">L</td> <td style="text-align: center;">H</td> <td style="text-align: center;">H</td> <td style="text-align: center;">3</td> </tr> <tr> <td style="text-align: center;">H</td> <td style="text-align: center;">L</td> <td style="text-align: center;">L</td> <td style="text-align: center;">4</td> </tr> <tr> <td style="text-align: center;">H</td> <td style="text-align: center;">L</td> <td style="text-align: center;">H</td> <td style="text-align: center;">5</td> </tr> <tr> <td style="text-align: center;">H</td> <td style="text-align: center;">H</td> <td style="text-align: center;">L</td> <td style="text-align: center;">6</td> </tr> <tr> <td style="text-align: center;">H</td> <td style="text-align: center;">H</td> <td style="text-align: center;">H</td> <td style="text-align: center;">7</td> </tr> </table>	<b>2</b>	<b>1</b>	<b>0</b>	<b>Common Driver</b>	L	L	L	0	L	L	H	1	L	H	L	2	L	H	H	3	H	L	L	4	H	L	H	5	H	H	L	6	H	H	H	7
<b>2</b>	<b>1</b>	<b>0</b>	<b>Common Driver</b>																																				
L	L	L	0																																				
L	L	H	1																																				
L	H	L	2																																				
L	H	H	3																																				
H	L	L	4																																				
H	L	H	5																																				
H	H	L	6																																				
H	H	H	7																																				
$\overline{\text{DSEL}}$	33	I	Display select. When $\overline{\text{DSEL}}$ is high, the LED is turned off. Note that, when BLANK is high, the LED is turned off with no regard to the $\overline{\text{DSEL}}$ input.																																				
DSEL	30	O	Display select output. The inverted data of $\overline{\text{DSEL}}$ is clocked out.																																				
GNDANA	21		Analog ground																																				
GNDLED	5, 43, 48		LED driver ground																																				
GNDLOG	37		Logic ground																																				
IREF	17	I	Constant current control setting. The LED current is set to the desired value by connecting an external resistor between IREF and GND.																																				
$\overline{\text{LATCH}}$	41	I	Latch. When $\overline{\text{LATCH}}$ is high, data on the shift register goes through latch. When $\overline{\text{LATCH}}$ is low, data is latched.																																				
SIN	42	I	Serial input for display																																				
SOUT	32	O	Serial output for display																																				
SCLK	40	I	Synchronous clock input for serial data transfer. The input data of SIN is synchronized to the rising edge of SCLK, and transferred to SOUT.																																				
S0 – S15	9, 10, 11, 12, 13, 14, 15, 16, 22, 23, 24, 25, 26, 27, 28, 29	O	LED segment driver output																																				
VANA	19		Analog power supply voltage																																				
VLOG	34		Logic power supply voltage																																				
VLED	8, 18, 31		LED driver power supply voltage																																				

# TLC5920

## 16x8 BIT LED DRIVER/CONTROLLER

SLAS264A – MARCH 2000 REVISED SEPTEMBER 2002

### absolute maximum ratings† (see Note 1)

Logic supply voltage, $V_{(LOG)}$	– 0.3 V to 7 V
LED supply voltage, $V_{(LED)}$	– 0.3 V to 7 V
Analog supply voltage, $V_{(ANA)}$	– 0.3 V to 7 V
Output current, $I_{OH(S)}$	– 32 mA
Output current, $I_{OL(C)}$	650 mA
Input voltage range, $V_I$	– 0.3 V to $V_{(LOG)} + 0.3$ V
Output voltage range, $V_O$	– 0.3 V to $V_{(LOG)} + 0.3$ V
Continuous total power dissipation	1500 mW
Thermal resistance	83°C/W
Operating free-air temperature range (see Note 2), $T_A$	– 20 to 85°C
Storage temperature range, $T_{stg}$	–40°C to 125°C

† Stresses beyond those listed under “absolute maximum ratings” may cause permanent damage to the device. These are stress ratings only, and functional operation of the device at these or any other conditions beyond those indicated under “recommended operating conditions” is not implied. Exposure to absolute-maximum-rated conditions for extended periods may affect device reliability.

- NOTES: 1. All voltage values are with respect to GND terminal.  
2.  $T_J \leq 150^\circ\text{C}$  (refer to appendix thermal condition).

### recommended operating conditions

#### dc characteristics (see Note 3)

PARAMETER	TEST CONDITIONS	MIN	NOM	MAX	UNIT
Logic supply voltage, $V_{(LOG)}$		4.5	5	5.5	V
LED supply voltage, $V_{(LED)}$		4.5	5	5.5	V
Analog power supply, $V_{(ANA)}$		4.5	5	5.5	V
Voltage between GND and $V_{(DEF)}$ , $G_{(DEF)}$	$G_{(DEF)} = GND_{(LOG)} - GND_{(LED)}$	–0.3	0	0.3	V
High-level input voltage, $V_{IH}$		2.0		$V_{(LOG)}$	V
Low-level input voltage, $V_{IL}$		$GND_{(LOG)}$		0.8	V
High-level output current, $I_{OH}$	$V_{(LOG)} = 4.5\text{V}$ , SOUT, DSEL			–1	mA
High-level output current, $I_{OH(S)}$	S0 to S15			–30	
Low-level output current, $I_{OL}$	$V_{(LOG)} = 4.5\text{V}$ , SOUT, DSEL			1.6	mA
Low-level output current, $I_{OL(C)}$	DUTY = 1/16, COM0 to COM7			640	
Operating free-air temperature range, $T_A$ (see Note 2)		–20		85	°C

- NOTES: 2.  $T_J \leq 150^\circ\text{C}$  (refer to appendix thermal condition).  
3.  $V_{ANA}$  must be same as  $V_{LED}$ .

#### ac characteristics ( $T_A = -20^\circ\text{C}$ to $85^\circ\text{C}$ )

PARAMETER	TEST CONDITIONS	MIN	NOM	MAX	UNIT
$f_{(SCLK)}$ Shift clock frequency				10	MHz
$t_{w(H)}/t_{w(L)}$ SCLK pulse duration (high- or low-level)		40			ns
$t_r/t_f$ Rise/fall time				100	ns
$t_{su}$ Setup time	SIN – SCLK	10			ns
	SCLK – LATCH	10			
$t_h$ Hold time	LATCH – SCLK	10			ns
	SIN – SCLK	10			



# TLC5920

## 16x8 BIT LED DRIVER/CONTROLLER

SLAS264A – MARCH 2000 REVISED SEPTEMBER 2002

electrical characteristics (unless otherwise noted),

MIN/MAX:  $V_{(LOG)} = V_{(ANA)} = V_{(LED)} = 4.5\text{ V to }5.5\text{ V}$ ,  $T_A = -20^\circ\text{C to }85^\circ\text{C}$

TYP:  $V_{(LOG)} = V_{(ANA)} = V_{(LED)} = 5\text{ V}$ ,  $T_A = 25^\circ\text{C}$

PARAMETER		TEST CONDITIONS	MIN	TYP	MAX	UNIT
$V_{OH}$	High-level output voltage	$I_{OH} = -1\text{ mA}$ , SOUT, DSEL	3.6			V
$V_{OL}$	Low-level output voltage	$I_{OL} = 1.6\text{ mA}$ , SOUT, DSEL			0.6	V
		$I_{OL} = 640\text{ mA}$ , COM0 to COM7		0.6	0.9	
$I_I$	Input current	$V_I = V_{(LOG)}$ or $GND_{(LOG)}$			$\pm 1$	$\mu\text{A}$
$I_{(LOG)}$	Supply current	Data transfer, SCLK = 10 MHz			0.1	mA
$I_{(LED)}$		LED is turned off		0.8	1.6	
$I_{(ANA)}$		LED is turned off		0.8	1.6	
$I_{OH(S03)}$	Segment current	$V_{(Sn)} = 2.5\text{ V}$ , $R_{(IREF)} = 4200\ \Omega$	-2.1	-3	-3.9	mA
$I_{OH(S10)}$		$V_{(Sn)} = 2.5\text{ V}$ , $R_{(IREF)} = 1260\ \Omega$	-8.5	-10	-11.5	
$I_{OH(S20)}$		$V_{(Sn)} = 2.5\text{ V}$ , $R_{(IREF)} = 630\ \Omega$	-17	-20	-23	
$I_{OH(S30)}$		$V_{(Sn)} = 2.5\text{ V}$ , $R_{(IREF)} = 420\ \Omega$	-25.5	-30	-34.5	
$\Delta I_{OH(S)}$	Segment current error between bits	$V_{(LED)} = 5\text{ V}$ , $R_{(IREF)} = 630\ \Omega$ , $V_{(Sn)} = 2.5\text{ V}$		$\pm 3\%$	$\pm 6\%$	
$V_{REF}$	Voltage reference		1.2	1.26	1.3	V

switching characteristics,  $C_L = 15\text{ pF}$

PARAMETER		TEST CONDITIONS	MIN	TYP	MAX	UNIT
$t_r$	Rise time	SOUT			40	ns
		DSEL			40	
		COMn			80	
		Sn			80	
$t_f$	Fall time	SOUT			40	ns
		DSEL			40	
		COMn			40	
		Sn			40	
$t_d$	Propagation delay time	$\overline{\text{LATCH}} - \text{Sn}$			40	ns
		SCLK - Sn			40	
		SCLK - SOUT			40	
		$\overline{\text{DSEL}} - \text{DSEL}$			40	
$t_{(DLH)}$	Propagation delay time	CSELn - COMn			120	ns
		$\overline{\text{DSEL}} - \text{COMn}$			120	
		BLANK - COMn			120	
$t_{(DHL)}$	Propagation delay time	CSELn - COMn			40	ns
		$\overline{\text{DSEL}} - \text{COMn}$			40	
		BLANK - COMn			40	

# TLC5920 16x8 BIT LED DRIVER/CONTROLLER

SLAS264A – MARCH 2000 REVISED SEPTEMBER 2002

## PARAMETER MEASUREMENT INFORMATION

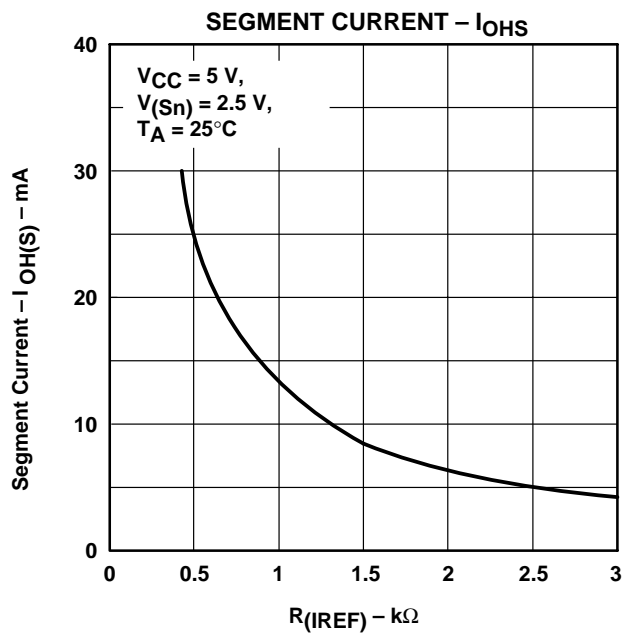
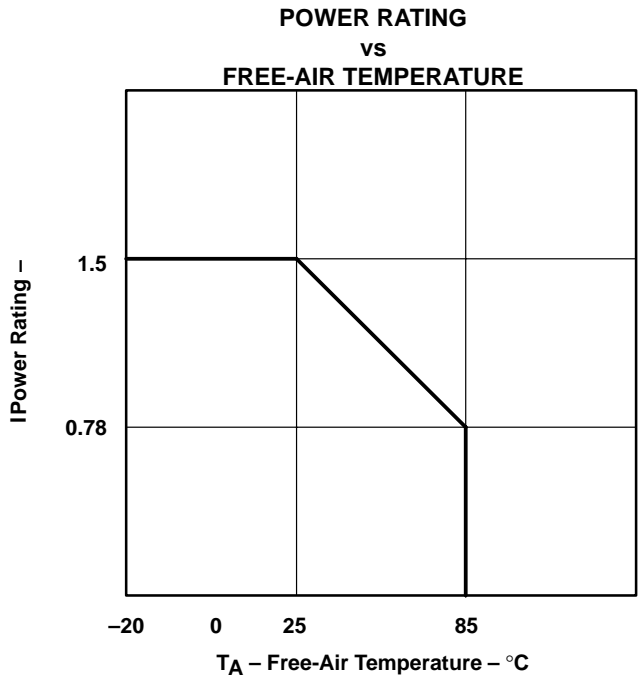

$$I_{OH(S)} = \frac{V_{REF}}{R_{(IREF)}} \times 10$$

timing diagram (common driver)

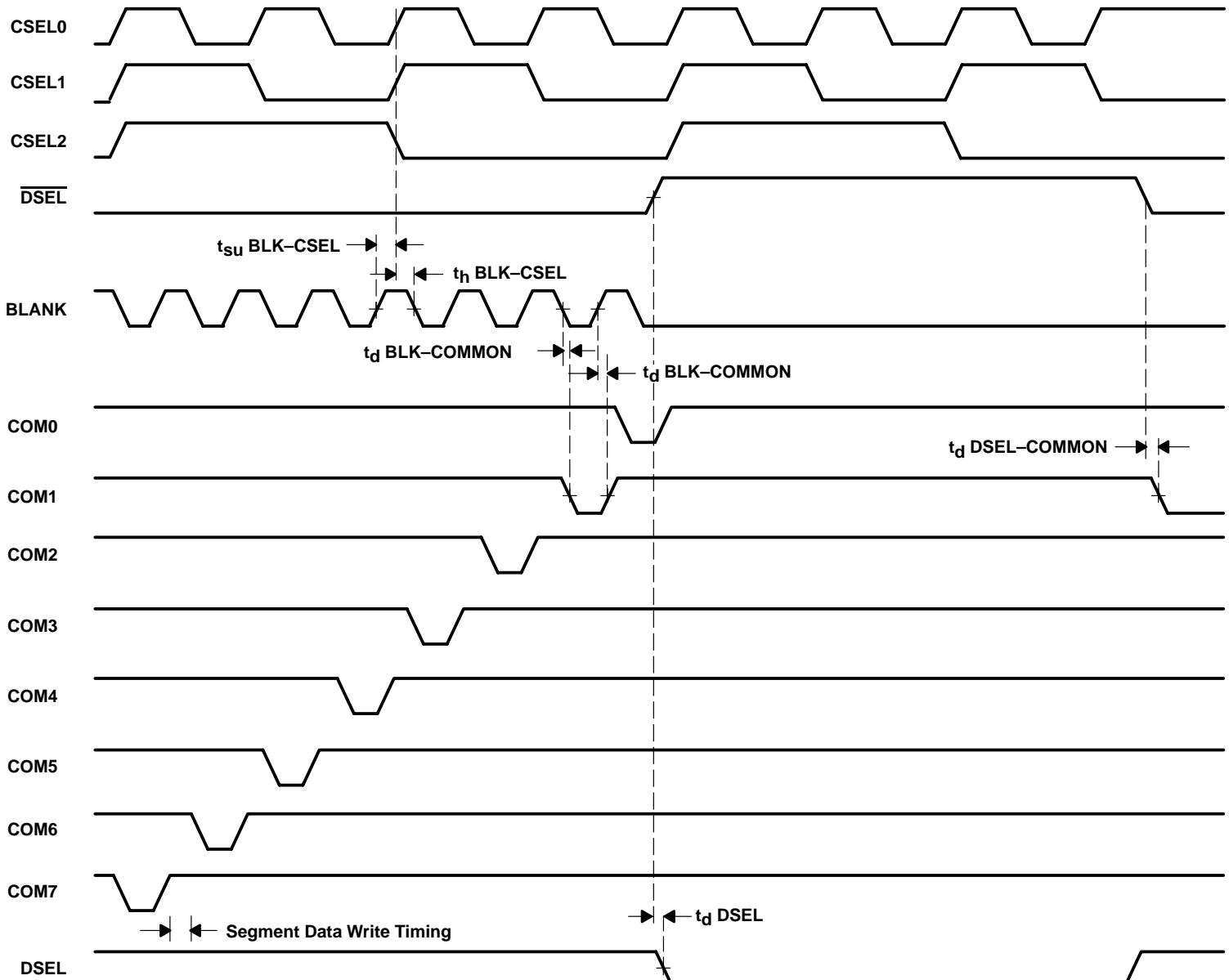

**TLC5920**  
**16x8 BIT LED DRIVER/CONTROLLER**

SLAS264A - MARCH 2000 REVISED SEPTEMBER 2002

timing diagram (segment driver)

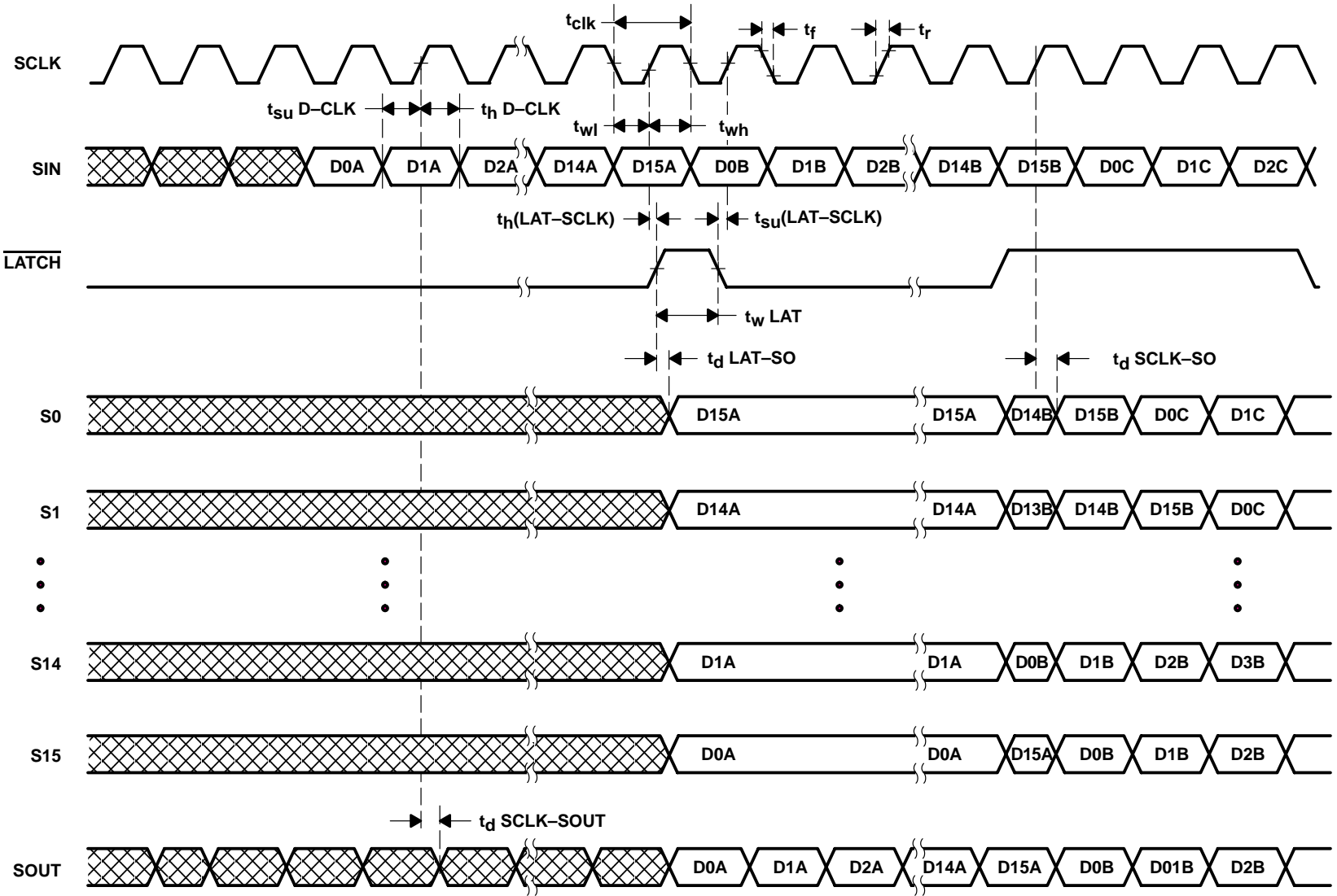



**APPLICATION INFORMATION**

**example 1**

The other remaining terminals used for dot matrix LED drive can be utilized for LED lamp drive and other displays.

**LEDs driven by TLC5920**

**cathode common type**

LED			TLC5920 QUANTITY	DUTY	DRIVE CURRENT (mA)
TYPE	NO. OF COLOR	QUANTITY			
LAMP	Mono	16	1	Static	30
	Two	8	1	Static	30
7 SEGMENT	Mono	16	1	1/8	30
	Two	8	1	1/8	30
5 x 7	Mono	3	1	1/8	30
	Two	1	1	1/8	30
8 x 8	Mono	2	1	1/8	30
	Two	1	1	1/8	30
16 x 16	Mono	2	2	1/16	20
	Two	1	2	1/16	20
	Three	1	3	1/16	13
24 x 24	Mono	2	3	1/24	13
	Two	1	3	1/24	13

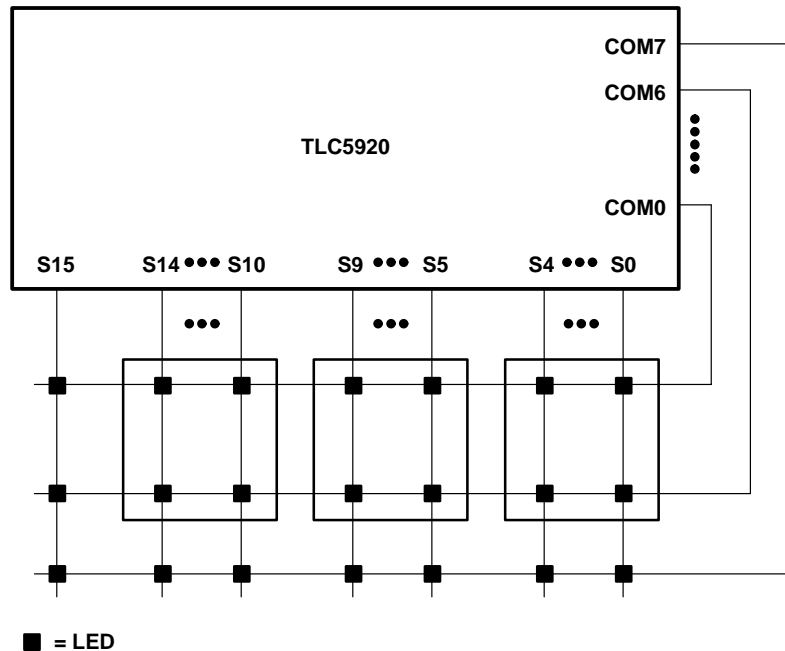

# TLC5920 16x8 BIT LED DRIVER/CONTROLLER

SLAS264A – MARCH 2000 REVISED SEPTEMBER 2002

## APPLICATION INFORMATION

### example 2

Using two TLC5920s, an LED with two colors and 16 x 16 dots can be driven. The number of LED arrays can also be increased by making a cascade connection in the application circuit.

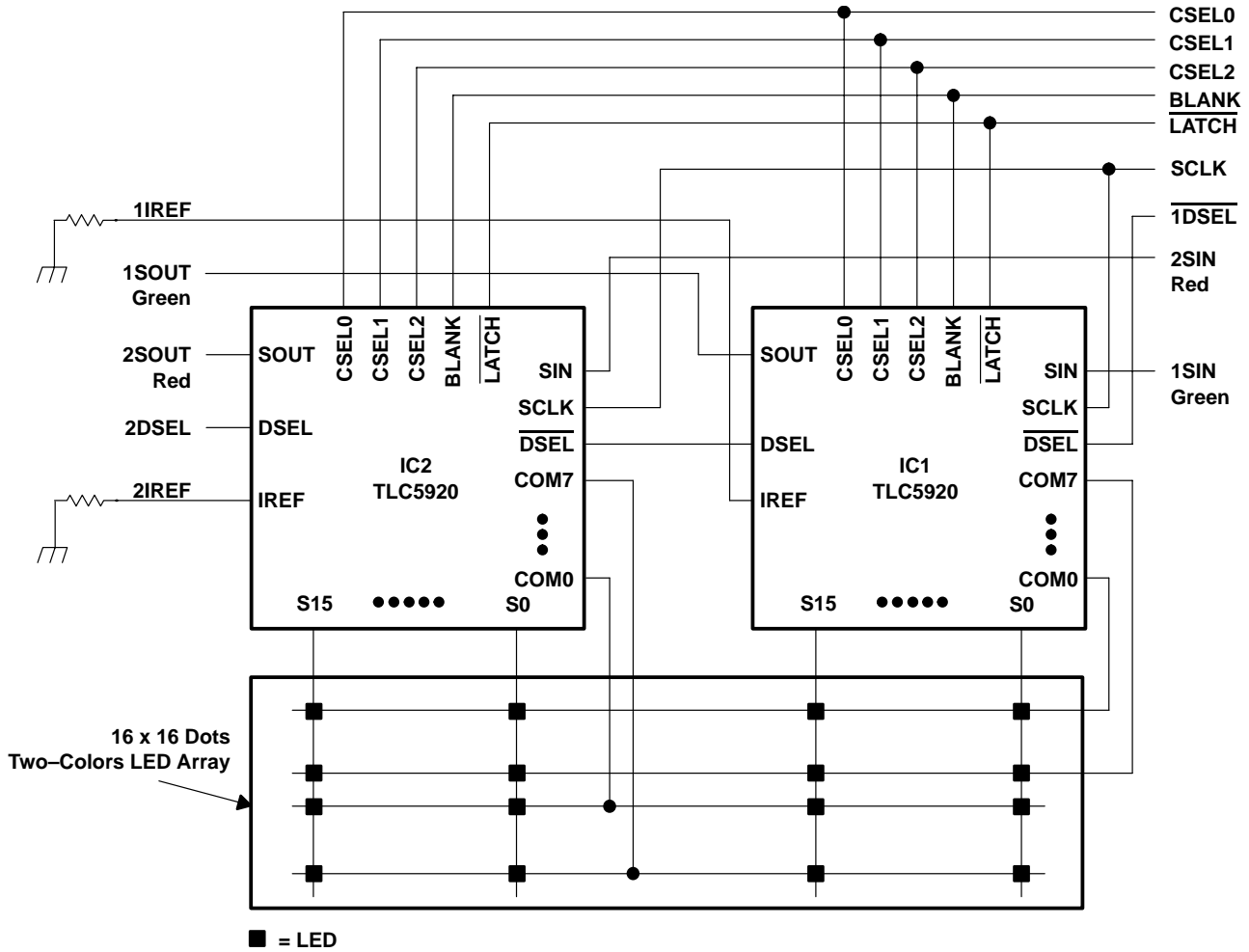

MECHANICAL DATA

DL (R-PDSO-G\*\*)

PLASTIC SMALL-OUTLINE PACKAGE

48 PINS SHOWN

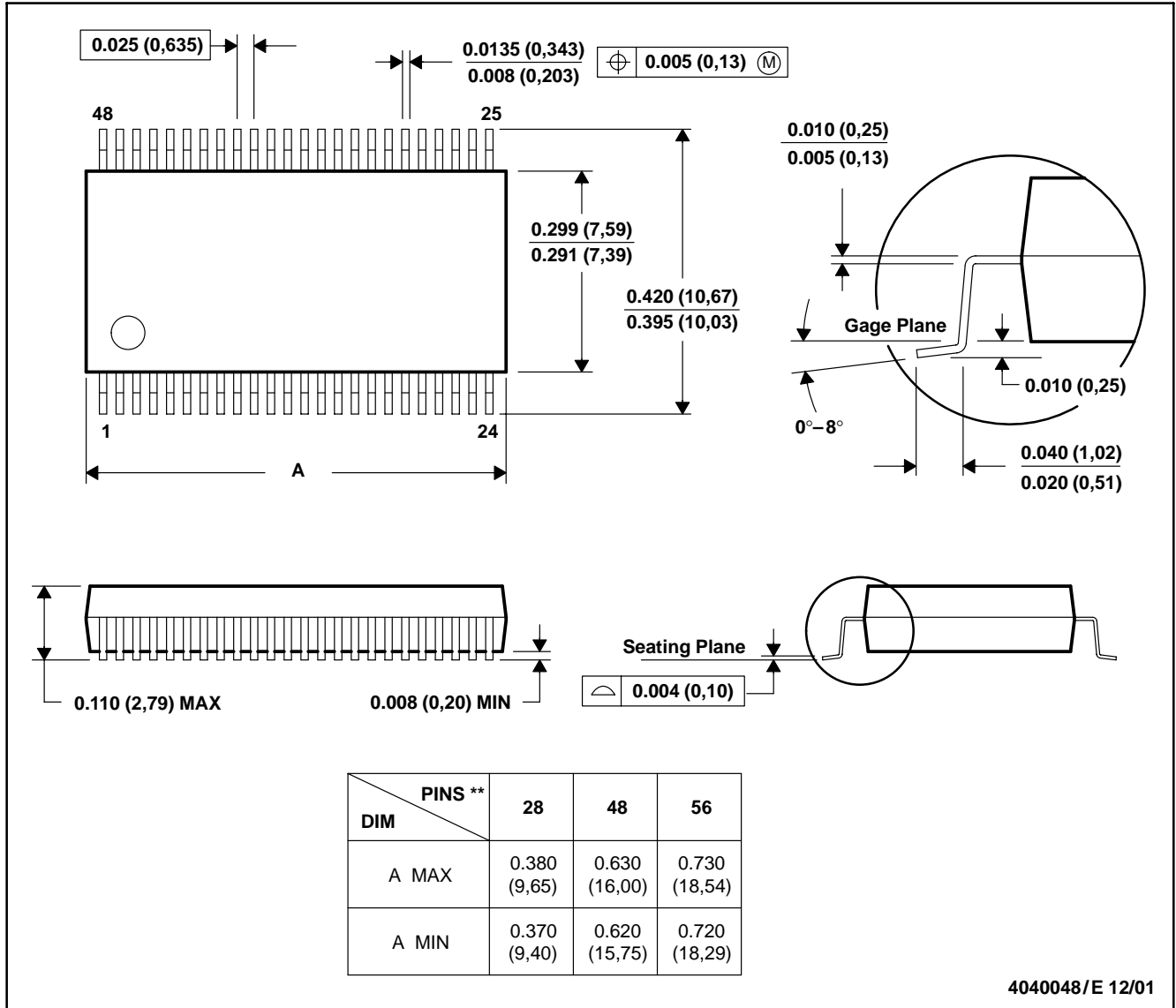

- NOTES: A. All linear dimensions are in inches (millimeters).  
 B. This drawing is subject to change without notice.  
 C. Body dimensions do not include mold flash or protrusion not to exceed 0.006 (0,15).  
 D. Falls within JEDEC MO-118

**PACKAGING INFORMATION**

Orderable Device	Status <sup>(1)</sup>	Package Type	Package Drawing	Pins	Package Qty	Eco Plan <sup>(2)</sup>	Lead/Ball Finish	MSL Peak Temp <sup>(3)</sup>
TLC5920DL	ACTIVE	SSOP	DL	48	25	Green (RoHS & no Sb/Br)	CU NIPDAU	Level-2-260C-1 YEAR
TLC5920DLG4	ACTIVE	SSOP	DL	48	25	Green (RoHS & no Sb/Br)	CU NIPDAU	Level-2-260C-1 YEAR
TLC5920DLR	ACTIVE	SSOP	DL	48	1000	Green (RoHS & no Sb/Br)	CU NIPDAU	Level-2-260C-1 YEAR
TLC5920DLRG4	ACTIVE	SSOP	DL	48	1000	Green (RoHS & no Sb/Br)	CU NIPDAU	Level-2-260C-1 YEAR

<sup>(1)</sup> The marketing status values are defined as follows:

**ACTIVE:** Product device recommended for new designs.

**LIFEBUY:** TI has announced that the device will be discontinued, and a lifetime-buy period is in effect.

**NRND:** Not recommended for new designs. Device is in production to support existing customers, but TI does not recommend using this part in a new design.

**PREVIEW:** Device has been announced but is not in production. Samples may or may not be available.

**OBSOLETE:** TI has discontinued the production of the device.

<sup>(2)</sup> Eco Plan - The planned eco-friendly classification: Pb-Free (RoHS), Pb-Free (RoHS Exempt), or Green (RoHS & no Sb/Br) - please check <http://www.ti.com/productcontent> for the latest availability information and additional product content details.

**TBD:** The Pb-Free/Green conversion plan has not been defined.

**Pb-Free (RoHS):** TI's terms "Lead-Free" or "Pb-Free" mean semiconductor products that are compatible with the current RoHS requirements for all 6 substances, including the requirement that lead not exceed 0.1% by weight in homogeneous materials. Where designed to be soldered at high temperatures, TI Pb-Free products are suitable for use in specified lead-free processes.

**Pb-Free (RoHS Exempt):** This component has a RoHS exemption for either 1) lead-based flip-chip solder bumps used between the die and package, or 2) lead-based die adhesive used between the die and leadframe. The component is otherwise considered Pb-Free (RoHS compatible) as defined above.

**Green (RoHS & no Sb/Br):** TI defines "Green" to mean Pb-Free (RoHS compatible), and free of Bromine (Br) and Antimony (Sb) based flame retardants (Br or Sb do not exceed 0.1% by weight in homogeneous material)

<sup>(3)</sup> MSL, Peak Temp. -- The Moisture Sensitivity Level rating according to the JEDEC industry standard classifications, and peak solder temperature.

**Important Information and Disclaimer:**The information provided on this page represents TI's knowledge and belief as of the date that it is provided. TI bases its knowledge and belief on information provided by third parties, and makes no representation or warranty as to the accuracy of such information. Efforts are underway to better integrate information from third parties. TI has taken and continues to take reasonable steps to provide representative and accurate information but may not have conducted destructive testing or chemical analysis on incoming materials and chemicals. TI and TI suppliers consider certain information to be proprietary, and thus CAS numbers and other limited information may not be available for release.

In no event shall TI's liability arising out of such information exceed the total purchase price of the TI part(s) at issue in this document sold by TI to Customer on an annual basis.

## TAPE AND REEL INFORMATION



### QUADRANT ASSIGNMENTS FOR PIN 1 ORIENTATION IN TAPE



\*All dimensions are nominal

Device	Package Type	Package Drawing	Pins	SPQ	Reel Diameter (mm)	Reel Width W1 (mm)	A0 (mm)	B0 (mm)	K0 (mm)	P1 (mm)	W (mm)	Pin1 Quadrant
TLC5920DLR	SSOP	DL	48	1000	330.0	32.4	11.35	16.2	3.1	16.0	32.0	Q1

TAPE AND REEL BOX DIMENSIONS



\*All dimensions are nominal

Device	Package Type	Package Drawing	Pins	SPQ	Length (mm)	Width (mm)	Height (mm)
TLC5920DLR	SSOP	DL	48	1000	346.0	346.0	49.0

## IMPORTANT NOTICE

Texas Instruments Incorporated and its subsidiaries (TI) reserve the right to make corrections, modifications, enhancements, improvements, and other changes to its products and services at any time and to discontinue any product or service without notice. Customers should obtain the latest relevant information before placing orders and should verify that such information is current and complete. All products are sold subject to TI's terms and conditions of sale supplied at the time of order acknowledgment.

TI warrants performance of its hardware products to the specifications applicable at the time of sale in accordance with TI's standard warranty. Testing and other quality control techniques are used to the extent TI deems necessary to support this warranty. Except where mandated by government requirements, testing of all parameters of each product is not necessarily performed.

TI assumes no liability for applications assistance or customer product design. Customers are responsible for their products and applications using TI components. To minimize the risks associated with customer products and applications, customers should provide adequate design and operating safeguards.

TI does not warrant or represent that any license, either express or implied, is granted under any TI patent right, copyright, mask work right, or other TI intellectual property right relating to any combination, machine, or process in which TI products or services are used. Information published by TI regarding third-party products or services does not constitute a license from TI to use such products or services or a warranty or endorsement thereof. Use of such information may require a license from a third party under the patents or other intellectual property of the third party, or a license from TI under the patents or other intellectual property of TI.

Reproduction of TI information in TI data books or data sheets is permissible only if reproduction is without alteration and is accompanied by all associated warranties, conditions, limitations, and notices. Reproduction of this information with alteration is an unfair and deceptive business practice. TI is not responsible or liable for such altered documentation. Information of third parties may be subject to additional restrictions.

Resale of TI products or services with statements different from or beyond the parameters stated by TI for that product or service voids all express and any implied warranties for the associated TI product or service and is an unfair and deceptive business practice. TI is not responsible or liable for any such statements.

TI products are not authorized for use in safety-critical applications (such as life support) where a failure of the TI product would reasonably be expected to cause severe personal injury or death, unless officers of the parties have executed an agreement specifically governing such use. Buyers represent that they have all necessary expertise in the safety and regulatory ramifications of their applications, and acknowledge and agree that they are solely responsible for all legal, regulatory and safety-related requirements concerning their products and any use of TI products in such safety-critical applications, notwithstanding any applications-related information or support that may be provided by TI. Further, Buyers must fully indemnify TI and its representatives against any damages arising out of the use of TI products in such safety-critical applications.

TI products are neither designed nor intended for use in military/aerospace applications or environments unless the TI products are specifically designated by TI as military-grade or "enhanced plastic." Only products designated by TI as military-grade meet military specifications. Buyers acknowledge and agree that any such use of TI products which TI has not designated as military-grade is solely at the Buyer's risk, and that they are solely responsible for compliance with all legal and regulatory requirements in connection with such use.

TI products are neither designed nor intended for use in automotive applications or environments unless the specific TI products are designated by TI as compliant with ISO/TS 16949 requirements. Buyers acknowledge and agree that, if they use any non-designated products in automotive applications, TI will not be responsible for any failure to meet such requirements.

Following are URLs where you can obtain information on other Texas Instruments products and application solutions:

### Products

Amplifiers	<a href="http://amplifier.ti.com">amplifier.ti.com</a>
Data Converters	<a href="http://dataconverter.ti.com">dataconverter.ti.com</a>
DLP® Products	<a href="http://www.dlp.com">www.dlp.com</a>
DSP	<a href="http://dsp.ti.com">dsp.ti.com</a>
Clocks and Timers	<a href="http://www.ti.com/clocks">www.ti.com/clocks</a>
Interface	<a href="http://interface.ti.com">interface.ti.com</a>
Logic	<a href="http://logic.ti.com">logic.ti.com</a>
Power Mgmt	<a href="http://power.ti.com">power.ti.com</a>
Microcontrollers	<a href="http://microcontroller.ti.com">microcontroller.ti.com</a>
RFID	<a href="http://www.ti-rfid.com">www.ti-rfid.com</a>
RF/IF and ZigBee® Solutions	<a href="http://www.ti.com/lprf">www.ti.com/lprf</a>

### Applications

Audio	<a href="http://www.ti.com/audio">www.ti.com/audio</a>
Automotive	<a href="http://www.ti.com/automotive">www.ti.com/automotive</a>
Broadband	<a href="http://www.ti.com/broadband">www.ti.com/broadband</a>
Digital Control	<a href="http://www.ti.com/digitalcontrol">www.ti.com/digitalcontrol</a>
Medical	<a href="http://www.ti.com/medical">www.ti.com/medical</a>
Military	<a href="http://www.ti.com/military">www.ti.com/military</a>
Optical Networking	<a href="http://www.ti.com/opticalnetwork">www.ti.com/opticalnetwork</a>
Security	<a href="http://www.ti.com/security">www.ti.com/security</a>
Telephony	<a href="http://www.ti.com/telephony">www.ti.com/telephony</a>
Video & Imaging	<a href="http://www.ti.com/video">www.ti.com/video</a>
Wireless	<a href="http://www.ti.com/wireless">www.ti.com/wireless</a>

Mailing Address: Texas Instruments, Post Office Box 655303, Dallas, Texas 75265  
Copyright © 2009, Texas Instruments Incorporated