

Supply voltage Supervisor TL77xx Series

Author: Eilhard Haseloff

Literature Number: SLVAE04
March 1997

IMPORTANT NOTICE

Texas Instruments (TI) reserves the right to make changes to its products or to discontinue any semiconductor product or service without notice, and advises its customers to obtain the latest version of relevant information to verify, before placing orders, that the information being relied on is current.

TI warrants performance of its semiconductor products and related software to the specifications applicable at the time of sale in accordance with TI's standard warranty. Testing and other quality control techniques are utilized to the extent TI deems necessary to support this warranty. Specific testing of all parameters of each device is not necessarily performed, except those mandated by government requirements.

Certain applications using semiconductor products may involve potential risks of death, personal injury, or severe property or environmental damage ("Critical Applications").

TI SEMICONDUCTOR PRODUCTS ARE NOT DESIGNED, INTENDED, AUTHORIZED, OR WARRANTED TO BE SUITABLE FOR USE IN LIFE-SUPPORT APPLICATIONS, DEVICES OR SYSTEMS OR OTHER CRITICAL APPLICATIONS.

Inclusion of TI products in such applications is understood to be fully at the risk of the customer. Use of TI products in such applications requires the written approval of an appropriate TI officer. Questions concerning potential risk applications should be directed to TI through a local SC sales office.

In order to minimize risks associated with the customer's applications, adequate design and operating safeguards should be provided by the customer to minimize inherent or procedural hazards.

TI assumes no liability for applications assistance, customer product design, software performance, or infringement of patents or services described herein. Nor does TI warrant or represent that any license, either express or implied, is granted under any patent right, copyright, mask work right, or other intellectual property right of TI covering or relating to any combination, machine, or process in which such semiconductor products or services might be or are used.

Contents

1. Introduction	1
2. Circuit Description.....	2
3. Application examples.....	5
4. Design Tips.....	12
5. Summary	14

List of Figures

1 Reset circuit	1
2 Functional Diagram.....	3
3 Diagram for Calculation of C_t	3
4 Timing diagram	4
5 TL7705A in 5 Volt Microcomputer Applications	6
6 Voltage Supervision of a multiple power supply	6
7 Typical Trigger Sensitivity at the SENSE input of the voltage monitor TL7705A.....	7
8 Circuit for Reduced Trigger Sensitivity	8
9 Modified Output Circuit	9
10 Circuit Diagram for Data Protection in a battery buffered memory	10
11 Typical Variation of the Reference Voltage V_{ref} versus supply Voltage Variations	10
12 Typical Variation of the Reference Voltage V_{ref} versus Ambient Temperature Variations	11
13 Buffered Circuit for the Reference Voltage	12
14 Printed Circuit Layout for the supply voltage supervisor	13
15 Series Resistor at the C_t input of the TL770xB	14

Supply Voltage Supervisor TL77xx Series

ABSTRACT

After power-on a digital system must be forced into a definite initial state. For microcomputers and microprocessors a Reset input is provided to which, in simple applications, an R/C network is connected. After power-on, this circuitry maintains the logic level at this input high (or low), until the supply voltage has reached its nominal value, and the internal logic of the microcomputer has executed the Reset. However, this simple circuit does not work well under all conditions, or during short drops of the supply voltage. This applications report describes the operation and the application of the supply voltage supervisor circuits series TL77xx, which has been specially designed to solve these applications problems.

1. Introduction

After power-on a digital system must normally be forced into a definite initial state. For microcomputers and microprocessors a reset input is provided to which, in simple applications, an R/C network is connected. After power-on, this circuitry maintains the logic level at this input high (or low), until the supply voltage has reached its nominal value, and the internal logic of the microcomputer has executed the initialization of the system.

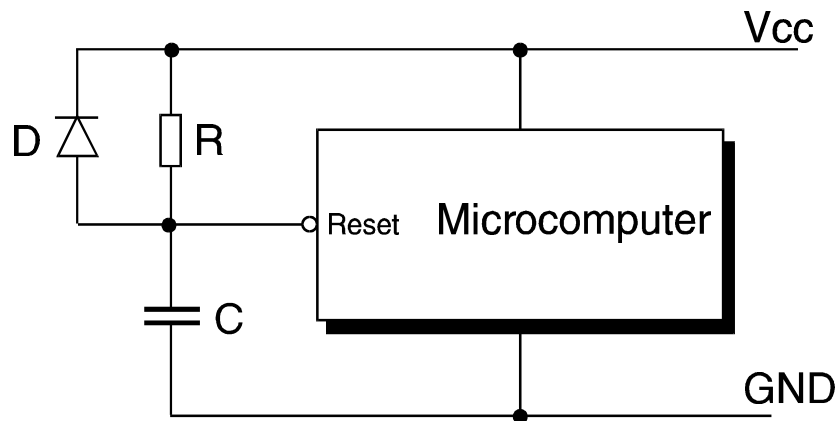

Figure 1. Reset circuit

However, this circuit does not work well during short drops of the supply voltage. In this case, the capacitor C must be quickly discharged via the diode D, which will occur only if the supply voltage V_{cc} goes below the threshold voltage (1 ... 2 Volt) of the Reset input. A small decrease of V_{cc} under the recommended minimum supply voltage can destroy the content of the memory and registers and yet not activate the reset circuit. This may have catastrophic consequences.

The following program example (8080 assembler code) tests an input:

```
WAIT    LXI    B,INPUT    ;load address
LOOP    LDAX  B           ;read input
        ANI   MASK       ;mask bit
        JNZ  LOOP        ;test
```

If, during the execution of the loop, the content of the B/C register is affected by a short voltage drop (causing an incorrect input to be read), an incorrect condition will be tested and an incorrect decision will be the consequence. Alternatively the addressed input will show a value which can never give a positive test result: the execution of the program seems to be stopped.

In larger computers several features are provided to prevent such errors: a power-fail interrupt signals dangerous conditions in time, the content of the memory is protected by a battery back-up, and so on. In small microcomputer systems this amount of effort is too expensive, and in most applications also not required. It is usually sufficient if, after a serious voltage drop, the microcomputer is forced into a defined initial condition. To implement this function, whilst preventing the problems mentioned above, the following circuit features are required:

- Accurate detection of a serious voltage drop.
- Generation of a reset signal while as the supply voltage is not in the operational range, to prevent undefined operations of the microcomputer.
- Maintenance of the reset signal for a certain time after the supply voltage has returned to its nominal value, to ensure proper initialization of the circuit.

For these applications, Texas Instruments has developed a series of integrated circuits which, with a minimum of external components and without additional adjustment, will fulfill the requirements described above.

2. Circuit Description

The main part of this circuit is a reference voltage source, which consists of a very stable, temperature-compensated band gap reference. An external capacitor (typ. 0.1μF) must be connected to the voltage output V_{ref} , to reduce the influence of fast transients in the supply voltage. The voltage at the SENSE input is divided by a resistor divider and compared with the reference voltage by a comparator. To achieve high accuracy, this divider is adjusted at wafer probe. When the input voltage is sensed to be lower than the threshold voltage, the thyristor is triggered, which discharges the timing capacitor C_t . It is also possible to fire the thyristor via the RESIN input by a logic level (TTL level, active low). The thyristor is turned off again when either the voltage at the SENSE input (or RESIN input) increases beyond the threshold, or - during short supply voltage drops - the discharge current of the capacitor becomes lower than the hold current of the thyristor.

Thereafter, the capacitor is recharged by a current source 100μA, the charge time being calculated as follows:

$$t_d = 1.3 \cdot 10^4 \cdot C_t \quad C_t \text{ in F, } t \text{ in s}$$

The magnitude of charge current and therefore also the delay t_d time is determined by the tolerance of the resistors in the integrated circuit. These tolerances, caused by the semiconductor manufacturing process, are not negligible. Therefore the delay time may vary -50% to +100%. However, for the applications discussed here this will not be a restriction. The diagram in figure 3 shows the typical delay time t_d versus the capacitance of the external capacitor C_t .

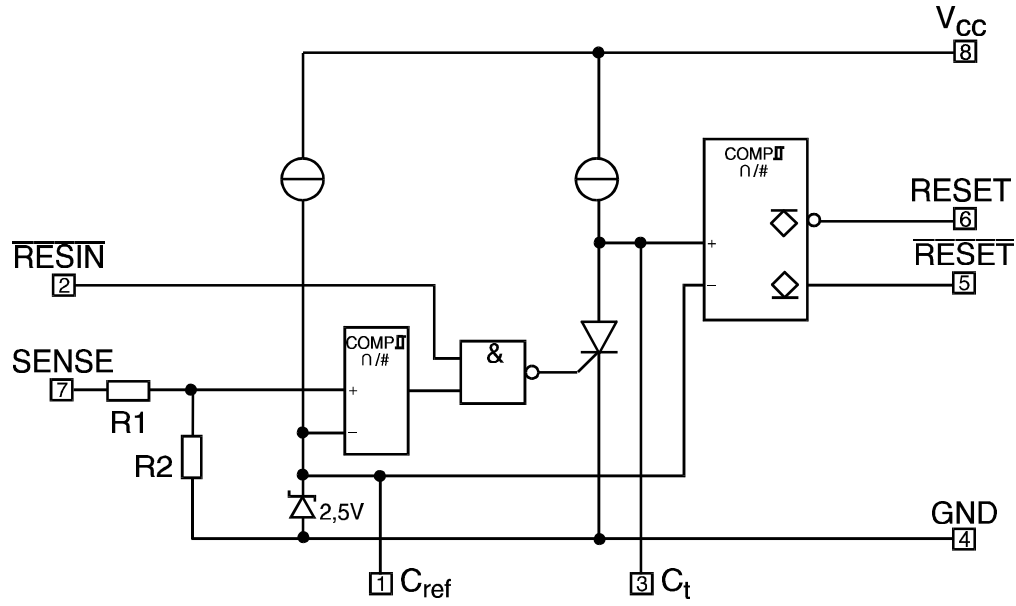

Note:

	R_{1typ}	R_{2typ}
TL7702	0	∞
TL7705	9.0 k Ω	10.0 k Ω
TL7709	20.4 k Ω	10.0 k Ω
TL7712	35.6 k Ω	10.0 k Ω
TL7715	46.8 k Ω	10.0 k Ω

Figure 2. Functional Diagram

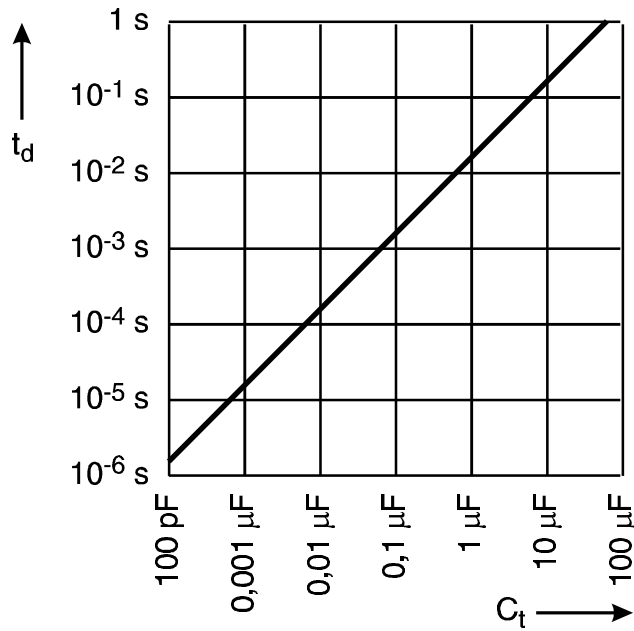
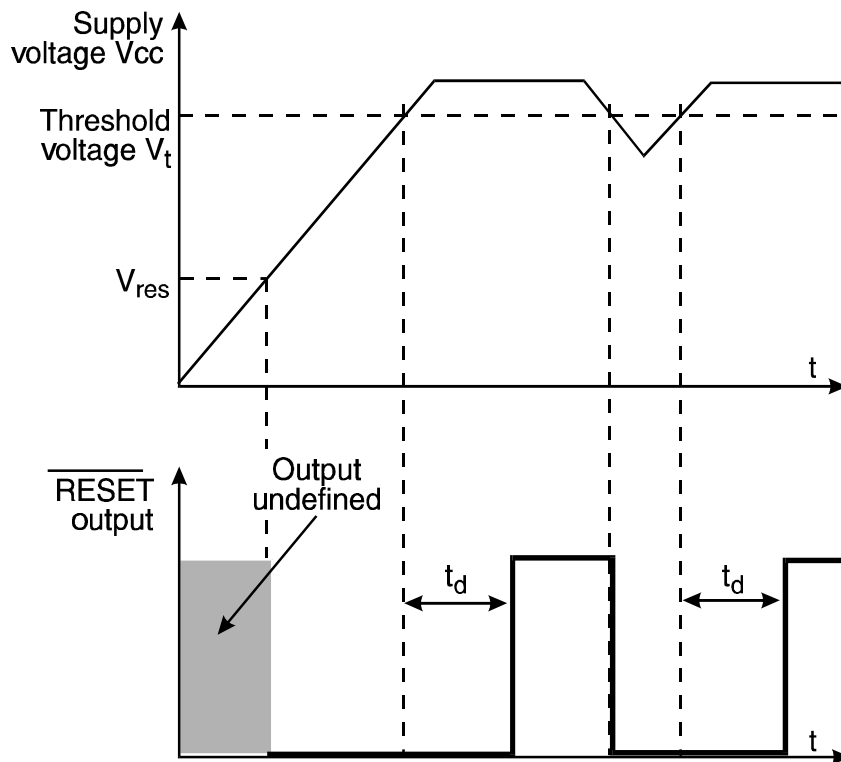

Figure 3. Diagram for Calculation of C_t

An additional comparator compares the voltage at the capacitor with the reference voltage and forces the outputs into the active state as long as the voltage at the capacitor is lower than the reference voltage.

Figure 4 shows the timing of the various signals. In this example the SENSE input is connected to the supply voltage V_{cc} as in typical applications of this device. The minimum supply voltage for which the function of this device is guaranteed is 3.6V. After power-on the outputs are undefined until the minimum supply voltage V_{res} is reached. For the TL77xxA the minimum supply voltage is $V_{res} = 3.0\text{ V}$ (typical 2.5 V), for the TL77xxB is $V_{res} = 1.0\text{ V}$. Also, when using the TL77xxB it has to be noted, that with such low supply voltages the function of the reset input of the following circuit may not be guaranteed.

Beyond the voltage V_{res} the capacitor C_t is first kept discharged, and the outputs stay in the active state (RESET = High, RESET = Low). When the input voltage becomes higher than the threshold voltage V_t , the thyristor is turned off and the capacitor is charged. After a delay, t_d , the voltage at the capacitor passes the trigger level of the output comparator and the outputs become inactive. The circuit to be initialized is now set to a defined state and starts the correct operation.



Note: SENSE Input connected to V_{cc}

Figure 4. Timing diagram

The thyristor is triggered again during voltage drops below the threshold voltage V_t and the reset sequence starts again. Also now the outputs stay in the active state for the time t_d after the return of the supply voltage to its required value. A hysteresis V_h at the input comparator prevents oscillation of the input circuit when the input voltage rises or falls slowly.

The time t_d - and also the capacitor C_t - are determined by the requirements of the following circuitry. In TTL or CMOS logic circuits, theoretically a reset time of 20 to 50ns is sufficient. For proper operation, microcomputers require a reset signal which lasts for several machine cycles and is thus of the order of 10 to 200 μs , according to the type of microcomputer in use. In a practical application, the delay time will be determined by characteristics of the power supply. Care has to be taken, that during and shortly after

power-on, short voltage fluctuations do not repetitively reset the system. Delay times of 10 to 20ms or even up to 500 ms will usually avoid these problems. Owing to an internal limitation of discharge current of the timing capacitor C_t , there is no upper limit for the size of this capacitor.

3. Application examples

Five versions of this circuit are available:

- **TL7705A, TL7705B** ($V_t = 4.55\text{ V}$): Application in TTL-systems and micro-computer systems which require a 5 volt supply (e.g. TMS7000)
- **TL7709A** ($V_t = 7.6\text{ V}$): Application in microcomputer systems using the TMS1XXXNLL.
- **TL7712A** ($V_t = 10.8\text{ V}$): Application in CMOS, microprocessor, and memory circuits with a 12 volt supply.
- **TL7715A** ($V_t = 13.5\text{ V}$): Application in circuits which operate with a supply voltage of 15 V, as is found often in analog circuits.
- **TL7702A, TL7702B** ($V_t = 2.5\text{ V}$): Application in systems where other supply voltages are used. The required trigger level may be adjusted with an external resistor divider at the SENSE input.

Since for most applications the circuits are already adjusted to the appropriate voltage levels, these devices are easy to use. Figure 5 shows the initialization circuit diagrams for TMS7000 microcomputer system with supply voltage $V_{cc} = 5\text{ V}$. The external components required are the decoupling capacitor C_{ref} for the reference voltage and the timing capacitor C_t . The outputs of the TL77xx are open collector outputs. In figure 5 therefore a pull-up resistor is shown at the RESET output to ensure the correct High level.

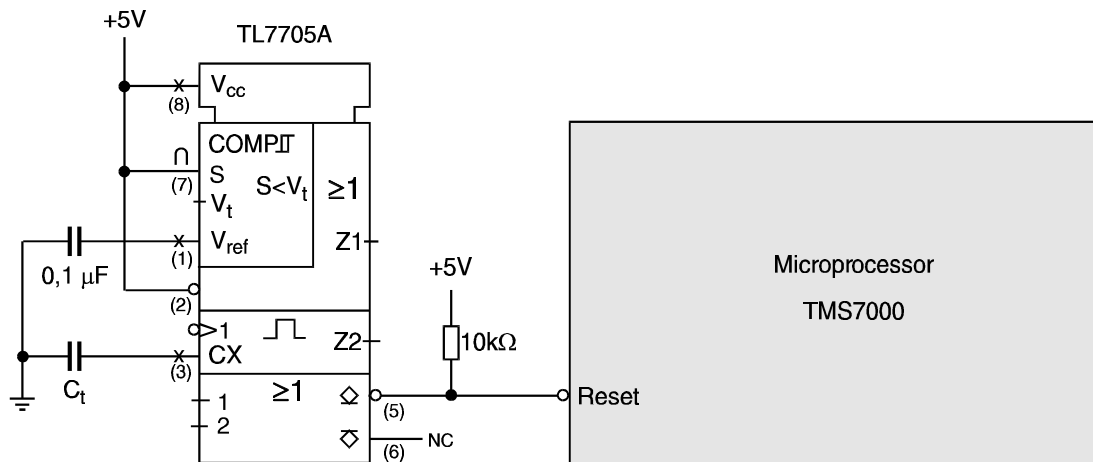

Figure 5. TL7705A in 5 Volt Microcomputer Applications

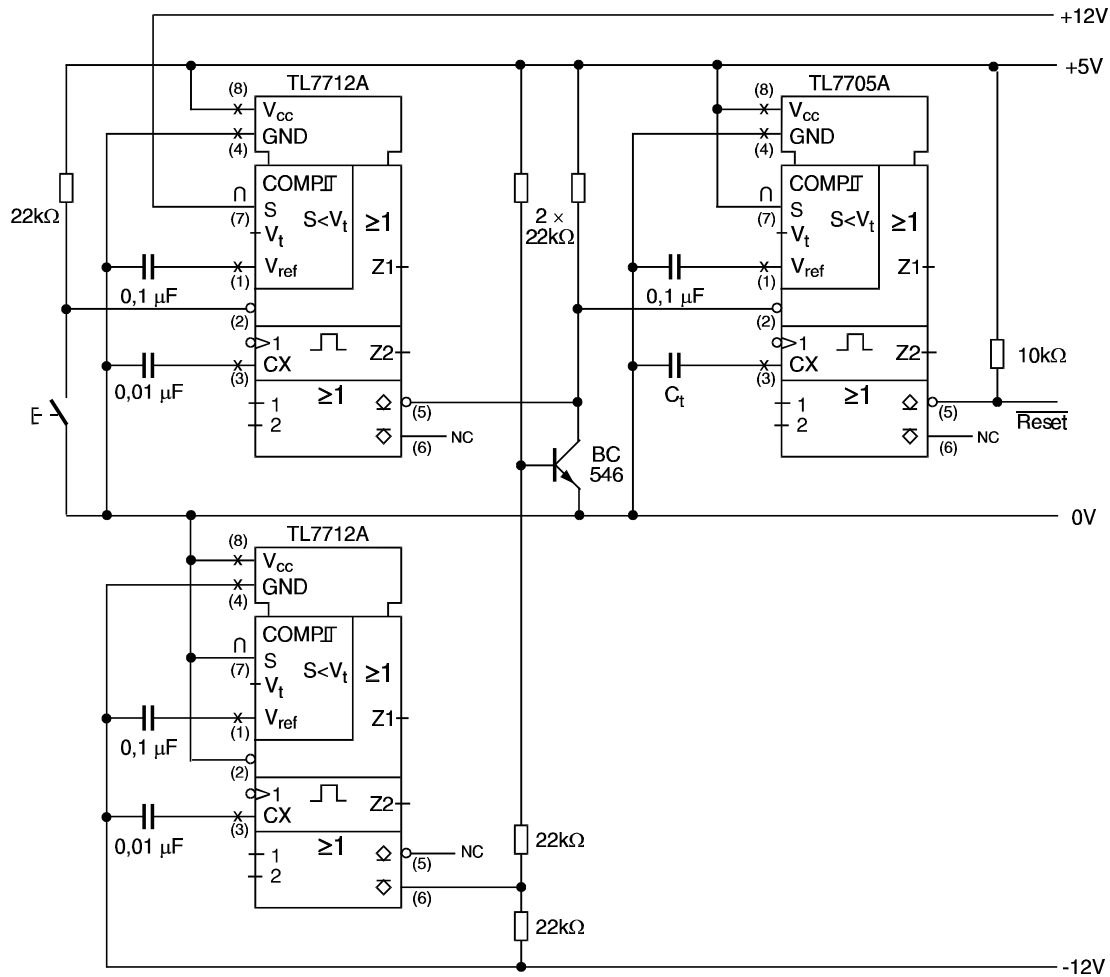

Figure 6. Voltage Supervision of a multiple power supply

In larger systems, where several supply voltages are required, it is necessary to supervise all supply voltages which may cause dangerous conditions in case of power failure. In the circuit diagram of figure 6, two TL7712A's are used to monitor the positive and the negative 12 volt supplies. Their outputs are fed to the RESIN input of the TL7705A, which monitors the 5 volt supply. The output of this device provides a reset signal, which becomes active whenever any one of the three supply voltages fails. A reset signal can be generated manually via a switch which is connected to the voltage monitor of the positive 12V supply.

When designing a supply voltage monitor the designer has to take care, that when only one of the supply voltages becomes marginal or fails, a defined reset signal is generated (at least if the main supply voltage 5 V is still available). Therefore the circuit which monitors the 12V supply voltage is supplied by the 5V supply. The reset signal of the circuit which monitors the negative supply is fed via a resistor divider to the base of the transistor BC546, which controls the RESIN input of the TL7705A. The voltage divider is designed so that a reset is generated even if the negative supply fails totally.

The capacitor which determines the delay of the two circuits which monitors the both 12v supplies, can be chosen short (in the example shown here it is 0.01 μF). The output of these circuits has only to trigger the third monitor TL7705A. The final duration of the reset signal will be determined by the capacitor C_t of the last mentioned circuit.

These supply voltage supervisor circuits were designed to detect supply voltage drops as short as >300 ns. In figure 7 the minimum pulse width t_{\min} at the SENSE input is shown versus the amplitude of the

supply voltage drop ΔV_{cc} which is required to trigger the voltage monitor. The sensitivity of the other circuits (TL7702, TL7712 etc.) can be calculated as proportional to the trigger voltage ratio.

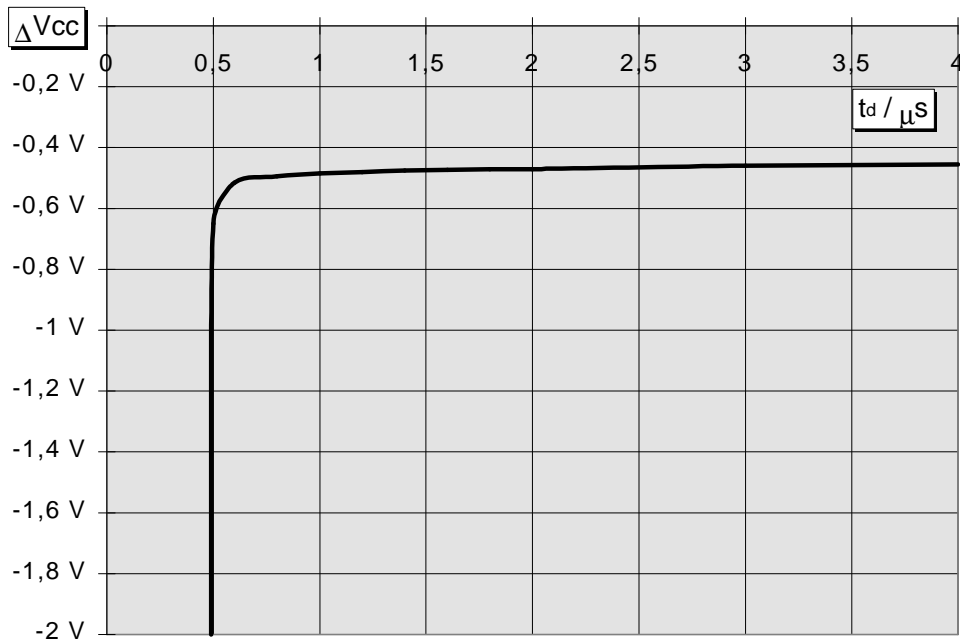

Figure 7. Typical Trigger Sensitivity at the SENSE input of the voltage monitor TL7705A

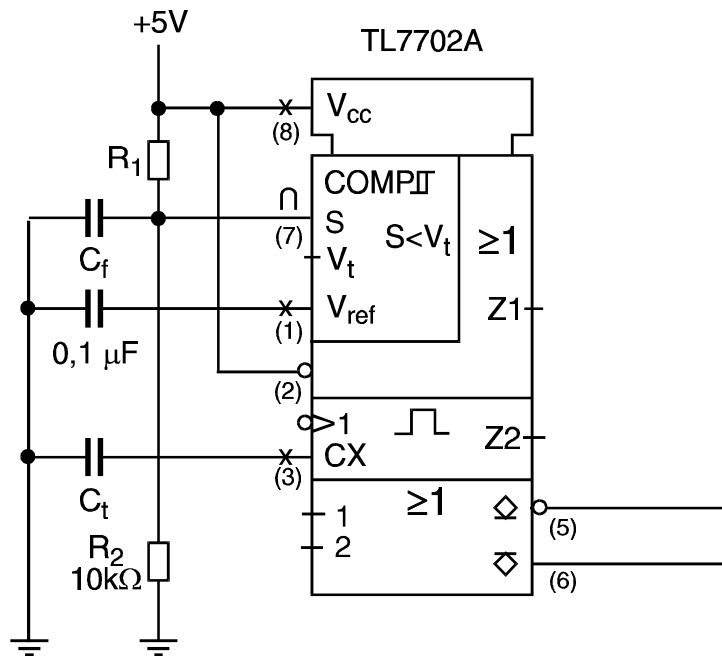

Figure 8. Circuit for Reduced Trigger Sensitivity

In applications where this performance is not required, sensitivity can be reduced by placing an R-C filter in front of SENSE input. To avoid an unacceptable change of the threshold voltage of circuits with a fixed threshold voltage (TL7705, TL7709, TL7712, TL7715) the value of the resistor should be a few 10Ω only. In application like this it may be better to use the TL7702A. With this circuit the threshold voltage can be set to the desired value by a high impedance voltage monitor. A small filter capacitor C_f at the SENSE input reduces the trigger sensitivity (figure 8).

In some applications it is necessary to keep the output of the reset circuit active even if no supply voltage is applied. Under normal conditions the output transistor of the TL77xxA is turned off (inactive state), when the supply voltage is lower than 3V ($V_{cc} > 1V$ for the TL77xxB). In figure 9 a P-channel field effect transistor is connected to the RESET output. This transistor conducts when the supply voltage drops below 3V i.e. at a gate source voltage of -3V or less. To ensure that the transistor is switched off when the supply voltage has reached the nominal value, the gate has to be at least 6V more positive than the source (or the required high level e.g. 2.4V). In figure 9 therefore the voltage monitor is supplied by supply voltage of 12V. Since the requirements for this supply voltage in terms of stability are not high, this supply voltage for example can be taken from the filter capacitor in front of the voltage regulator in the power supply.

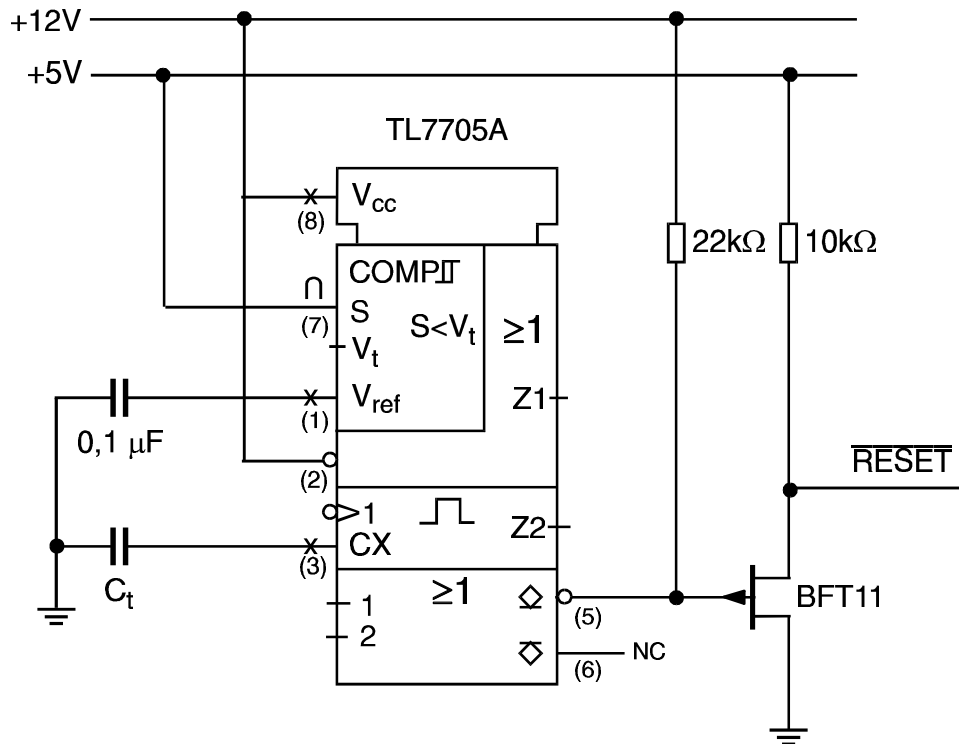

Figure 9. Modified Output Circuit

A further application for these integrated circuits is in battery-buffered memory systems. When the line voltage fails, the content of the memory must not be corrupted by a random write operation of the microcomputer. These uncontrolled write operations may take place at low supply voltage even if a reset signal is applied to the processor. Generally, it is sufficient to switch the chip select line into the inactive state (some memories require that the write line also be disabled). A switch, which consists of transistor Q_1 and diode D_1 , is inserted into the chip select line of the memory. Under normal operation (line voltage present) the output of the TL7705B is turned off (high); the transistor Q_1 draws its base current from transistor Q_2 and resistor R_1 . When the chip select line is switched from high to low by the supervising microprocessor, the transistor conducts and the CS input of the memory goes low and the memory is enabled. Because of the small DC load of the resistor R_2 , the saturation voltage of the transistor (and

therefore the shift of the low level at the CS input) is very small (typ. 40mV). When the chip select line is switched high again by the processor, the transistor Q is turned off (the influence of the inverse current gain is negligible); the diode D₁ conducts and charges the circuit capacitance. In the case of a power-failure the TL7705B is triggered and its RESET output becomes low. The base of transistor Q can no longer draw current. Thus the CS input of the memory is separated from the chip select line.

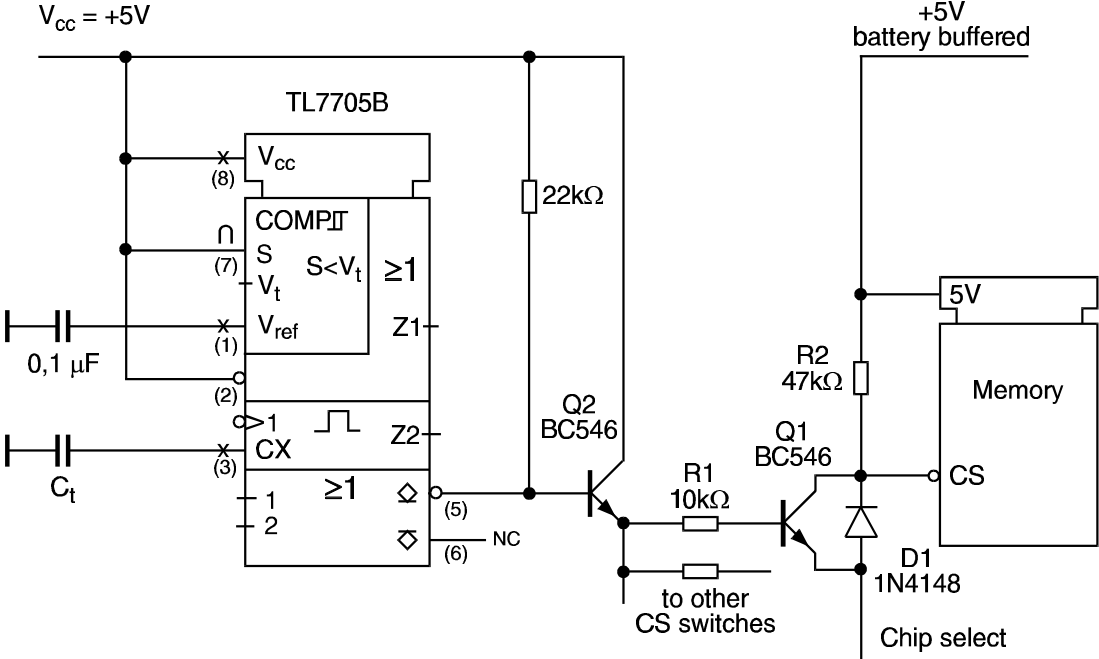

Figure 10. Circuit Diagram for Data Protection in a battery buffered memory

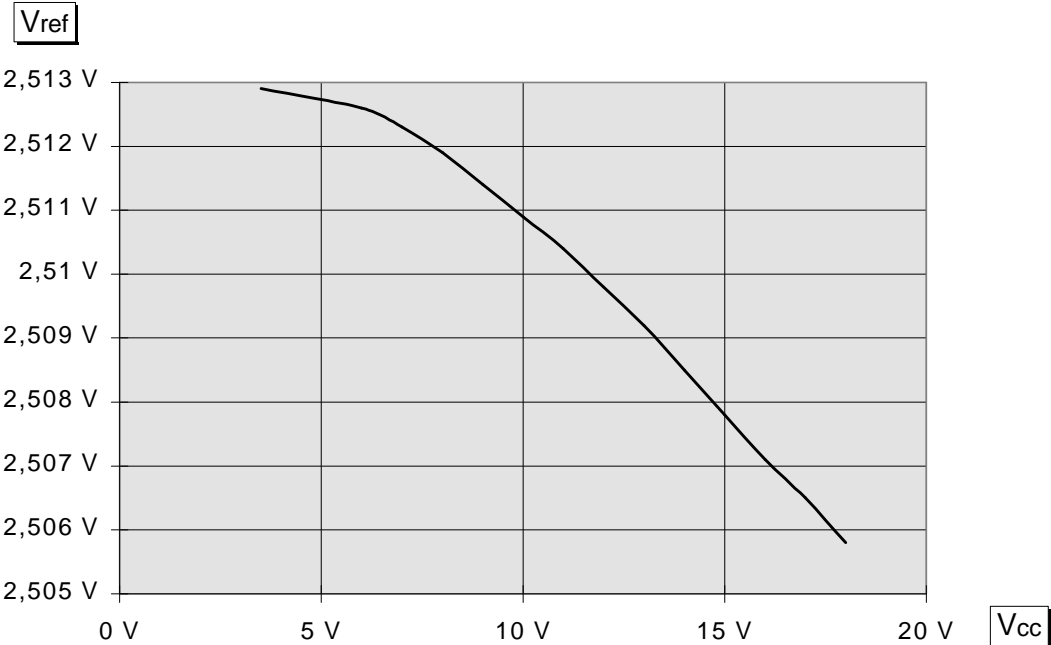

Figure 11. Typical Variation of the Reference Voltage V_{ref} versus supply Voltage Variations

As has already been mentioned the supply voltage supervisors of the series TL77xxA incorporate extremely stable reference voltage source which can be accessed at the V_{ref} terminal. This voltage source can also be used when in other applications a constant voltage source is required. As shown in picture 11, the reference voltage V_{ref} varies less than 10 mV, when the supply voltage is changed from 3.5 ... 18 V.

The same stability of the reference voltage is maintained, when the ambient temperature is changed. Figure 12 shows the typical characteristic. The reference voltage varies only 16mV, when the ambient temperature is changed from -40 ... 85 °C.

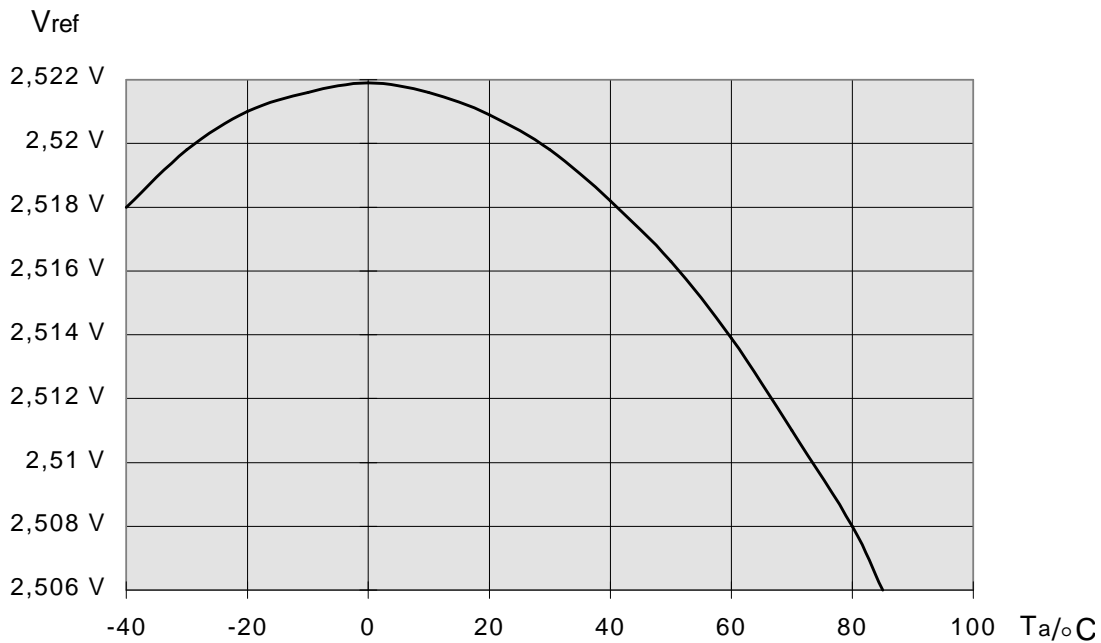

Figure 12. Typical Variation of the Reference Voltage V_{ref} versus Ambient Temperature Variations

When using the integrated reference voltage to supply other circuits, the designer has to consider that maximum current available from this voltage source is in the order of 100 μ A only. With higher loads, the stability of the reference voltage suffers. For higher currents a buffer in the form of an operational amplifier connected as an emitter follower is recommended (figure 13). If the voltage monitor section of the circuit is not used in this application, the capacitor C_i is not required. This terminal may then be left open. The inputs SENSE and RESIN are connected to ground.

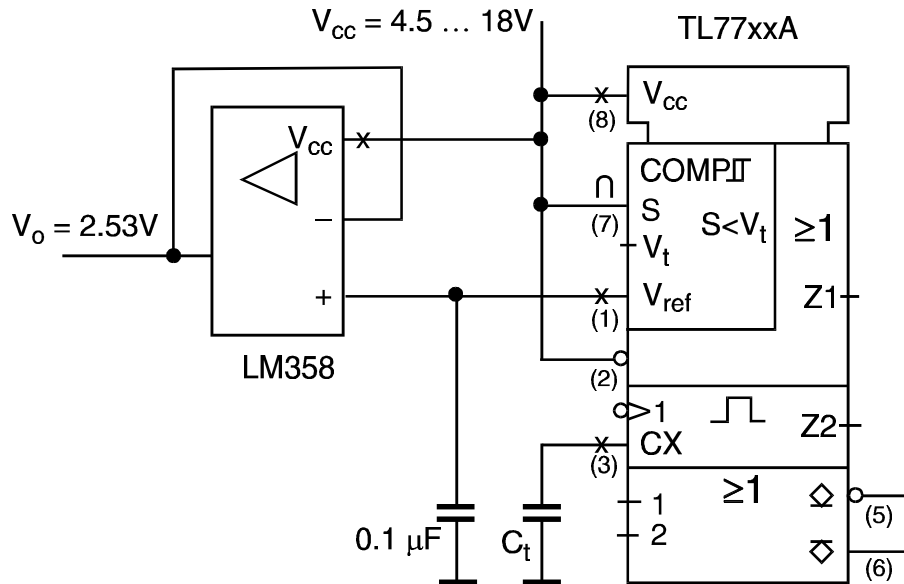

Figure 13. Buffered Circuit for the Reference Voltage

4. Design Tips

The application of the supply voltage supervisors of the series TL77xx is not complicated. However it should be noticed, that this circuit is an analog circuit, whose function and performance - e.g. the stability of the reference voltage - may be negatively influenced by noise in the neighboring circuits. Therefore the voltage monitor should be placed on the printed circuit board, where there are no neighboring circuits in the which switch high currents (like bus interface circuits and power switches). When laying out the layout of the printed circuit board special care should taken with the interconnects which carry analog signals. Beside the SENSE input these are the C_f and V_{ref} terminals. Noise coupled into the C_f input will lead to a reduction of the output pulse width. Noise coupled into the V_{ref} input or into the filter capacitor at this input may lead to undesired triggering of the circuit and by this to an undesired RESET pulse. Practice shows, that this malfunction when high currents flow over the interconnects of these capacitors to the GND terminal of the voltage monitor. To avoid these effects, the GND terminals of these capacitors must be connected by the shortest way to the GND terminal of the voltage monitor in so that no currents caused by other circuits flow over these wires. Figure 14 show a layout proposal for the printed circuit board. Furthermore the resistors of the voltage divider at the SENSE input of the TL7702 (R_2 and R_3 in figure 14) have to be placed in so, that no noise may be coupled into this circuit.

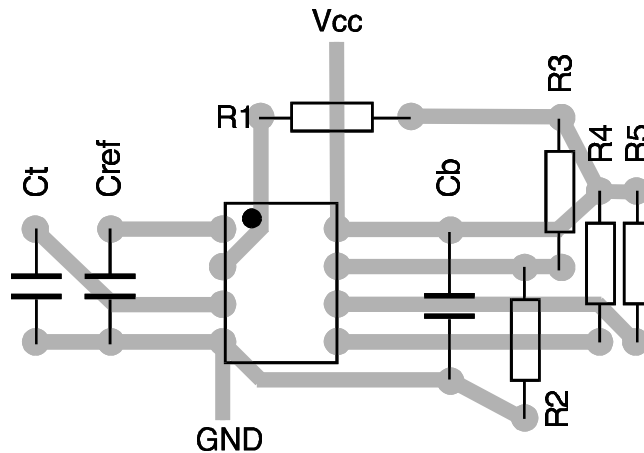

Figure 14. Printed Circuit Layout for the supply voltage supervisor

When using the supply voltage supervisor TL770xB in certain applications a current limiting resistor R_t (figure 15) in series to the capacitor C_t (pin 3) is required. With this circuit the timing capacitor will be charged up to the supply voltage V_{cc} respectively an internal clamping (= 7.1 V), where the smaller of the these two voltages determines the final voltage at the capacitor. When the supply voltage drops quickly down to a voltage which is lower than the current voltage at the capacitor C_t , a parasitic current path may be turned on which in turn erroneously activates the outputs. This effect is avoided when the mentioned parasitic current I_p stays below 1 mA. Considering this the resistor R_t is calculated as follows:

$$R_t = \geq \frac{V_{Ctmax} - V_t}{1mA}$$

where V_t = threshold voltage of the SENSE input

$V_{Ctmax} = V_{ccmax}$ or 7 V, the lower of these values apply

When using the TL7705B ($V_t = 4.55$ V) with a maximum supply voltage $V_{cc} = 5.5$ V, one gets:

$$R_t = \geq \frac{5.5V - 4.55V}{1mA} = 950$$

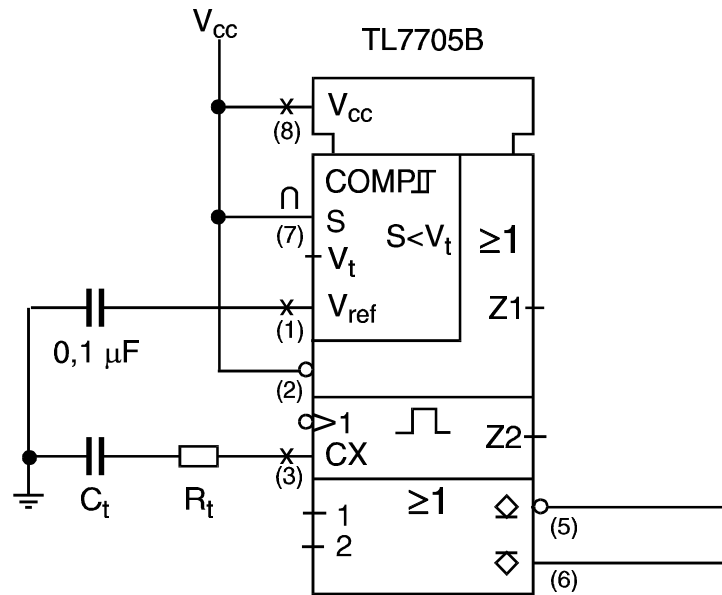

Figure 15. Series Resistor at the C_t input of the TL770xB

To a small degree this resistor influences the delay time t_d . In most applications however this effect can be neglected, because - when determining the length of the reset pulse - a large reserve is taken into account.

When designing a supply voltage supervision circuit often an analysis of the noise on the supply lines is required. The probes of the oscilloscope usually used for this kind of measurement mostly are not capable of performing the measurements correctly. The main reason is the ground wire attached to the probe. This wire often acts as an antenna which receives all the noise generated by the surrounding circuits. This leads to a wrong display on the oscilloscope screen. More accurate results are found, when the signal to be measured is taken via a $0.1 \mu\text{F}$ capacitor (to block the DC voltage) directly soldered to the point of measurement. The other end of the capacitor is connected to a coaxcable, whose shield is connected by the shortest path to the next ground reference point. The coaxcable leads to the input of the oscilloscope, where the cable has to be terminated correctly to avoid line reflections.

5. Summary

Monitoring of the supply voltage is absolutely mandatory to guarantee a correct initialization of the circuit and to detect undefined operating condition e.g. an undervoltage. This report shows several application examples for the supply voltage supervisor circuits of the series TL77xxA. Owing their very accurate threshold voltage, they can be easily designed into systems, replacing expensive discrete circuits .