

TIC10024-Q1 24-Input Multiple Switch Detection Interface (MSDI) Device With Adjustable Wetting Current for Automotive Systems

1 Features

- Qualified for Automotive Applications
- AEC-Q100 Qualified With the Following Results:
 - Device Temperature Grade 1: -40°C to 125°C Ambient Operating Temperature
 - Device HBM ESD Classification Level H2
 - Device CDM ESD Classification Level C4B
- Designed to Support 12-V Automotive Systems with Over-voltage and Under-voltage Warning
- Monitors up to 24 Direct Switch Inputs with 10 Inputs Configurable to Monitor Switches Connected to Either Ground or Battery
- Switch Input Withstands up to 40 V (Load Dump Condition) and down to -24 V (Reverse Polarity Condition)
- 6 Configurable Wetting Current Settings: (0 mA, 1 mA, 2 mA, 5 mA, 10 mA, and 15 mA)
- Integrated Comparator with 4 Programmable Thresholds for Digital Switch Monitoring
- Ultra-low Operating Current in Polling Mode: 68 μA Typical ($t_{\text{POLL}} = 64$ ms, $t_{\text{POLL_ACT}} = 128$ μs , All 24 Inputs Active, Comparator Mode, All Switches Open)
- Interfaces Directly to MCU Using 3.3 V / 5 V Serial Peripheral Interface (SPI) Protocol
- Interrupt Generation to Support Wake-Up Operation on All Inputs
- ± 8 kV Contact Discharge ESD Protection on Input Pins per ISO-10605 With Appropriate External Components
- 38-Pin TSSOP Package

2 Applications

- Body Control Module and Gateway
- Automotive Lighting
- Heating and Cooling
- Power Seats
- Mirrors

3 Description

The TIC10024-Q1 is an advanced Multiple Switch Detection Interface (MSDI) device designed to detect external switch status in a 12-V automotive system. The TIC10024-Q1 features a comparator with adjustable thresholds to monitor digital switches independently of the MCU. The device monitors 24 direct switch inputs, with 10 inputs configurable to monitor switches connected to either ground or battery. 6 unique wetting current settings can be programmed for each input to support different application scenarios. The device supports wake-up operation on all switch inputs to eliminate the need to keep the MCU active continuously, thus reducing power consumption of the system. The TIC10024-Q1 also offers integrated fault detection and ESD protection for improved system robustness. The TIC10024-Q1 supports 2 modes of operations: continuous and polling mode. In continuous mode, wetting current is supplied continuously. In polling mode, wetting current is turned on periodically to sample the input status based on a programmable timer, thus the system power consumption is significantly reduced.

Device Information⁽¹⁾

PART NUMBER	PACKAGE	BODY SIZE (NOM)
TIC10024-Q1	TSSOP (38)	9.70 mm x 4.40 mm

(1) For all available packages, see the orderable addendum at the end of the data sheet.

Simplified Schematic

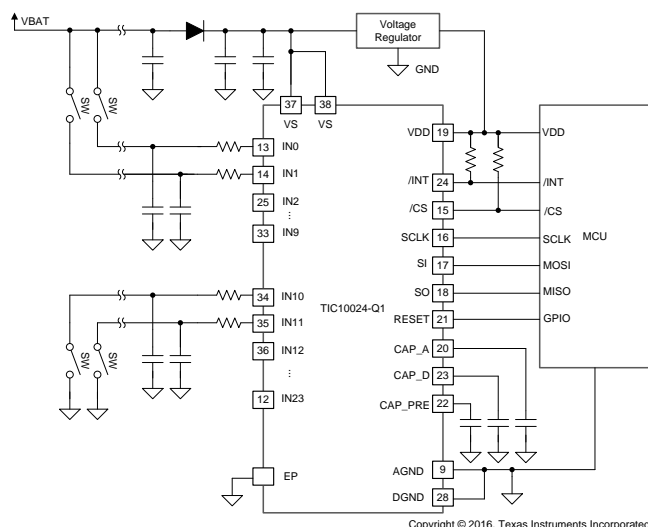

Copyright © 2016, Texas Instruments Incorporated



Table of Contents

<p>1 Features 1</p> <p>2 Applications 1</p> <p>3 Description 1</p> <p>4 Revision History..... 2</p> <p>5 Pin Configuration and Functions 3</p> <p>6 Specifications..... 5</p> <p> 6.1 Absolute Maximum Ratings 5</p> <p> 6.2 ESD Ratings 5</p> <p> 6.3 Recommended Operating Conditions 5</p> <p> 6.4 Thermal Information 6</p> <p> 6.5 Electrical Characteristics 6</p> <p> 6.6 Timing Requirements 9</p> <p> 6.7 Typical Characteristics 10</p> <p>7 Parameter Measurement Information 11</p> <p>8 Detailed Description 12</p> <p> 8.1 Overview 12</p> <p> 8.2 Functional Block Diagram 13</p> <p> 8.3 Feature Description 14</p> <p> 8.4 Device Functional Modes 26</p> <p>9 Programming..... 33</p>	<p> 9.1 SPI Communication Interface Buses 33</p> <p> 9.2 SPI Sequence 34</p> <p> 9.3 Programming Guidelines 36</p> <p> 9.4 Register_Maps 36</p> <p>10 Application and Implementation..... 65</p> <p> 10.1 Application Information 65</p> <p> 10.2 Digital Switch Detection in Automotive Body Control Module 65</p> <p> 10.3 Systems Examples 68</p> <p>11 Power Supply Recommendations 71</p> <p>12 Layout..... 72</p> <p> 12.1 Layout Guidelines 72</p> <p> 12.2 Layout Example 73</p> <p>13 Device and Documentation Support 74</p> <p> 13.1 Receiving Notification of Documentation Updates 74</p> <p> 13.2 Community Resources 74</p> <p> 13.3 Trademarks 74</p> <p> 13.4 Electrostatic Discharge Caution 74</p> <p> 13.5 Glossary 74</p> <p>14 Mechanical, Packaging, and Orderable Information 74</p>
---	---

4 Revision History

DATE	REVISION	NOTES
September 2017	*	Initial release.

5 Pin Configuration and Functions

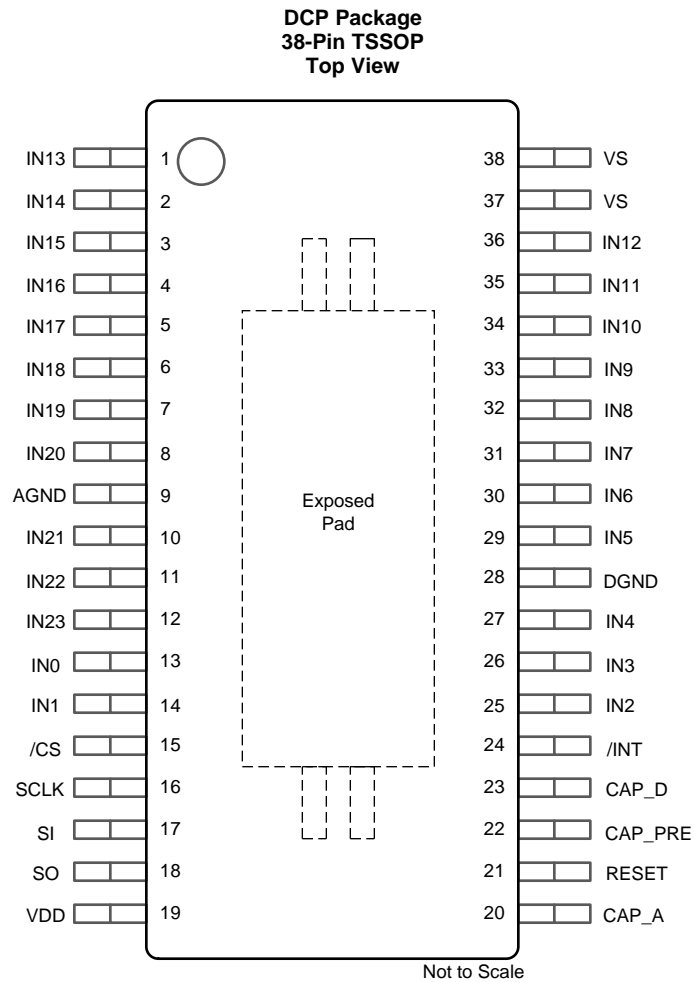

Pin Functions

PIN		TYPE ⁽¹⁾	DESCRIPTION
NO.	NAME		
1	IN13	I/O	Ground switch monitoring input with current source
2	IN14	I/O	Ground switch monitoring input with current source
3	IN15	I/O	Ground switch monitoring input with current source
4	IN16	I/O	Ground switch monitoring input with current source
5	IN17	I/O	Ground switch monitoring input with current source
6	IN18	I/O	Ground switch monitoring input with current source
7	IN19	I/O	Ground switch monitoring input with current source
8	IN20	I/O	Ground switch monitoring input with current source
9	AGND	P	Ground for analog circuitry
10	IN21	I/O	Ground switch monitoring input with current source
11	IN22	I/O	Ground switch monitoring input with current source
12	IN23	I/O	Ground switch monitoring input with current source
13	IN0	I/O	Ground/ V_{BAT} switch monitoring input with configurable current sink or source.
14	IN1	I/O	Ground/ V_{BAT} switch monitoring input with configurable current sink or source.

(1) I = input, O = output, I/O = input and output, P = power.

Pin Functions (continued)

PIN		TYPE ⁽¹⁾	DESCRIPTION
NO.	NAME		
15	$\overline{\text{CS}}$	I	Active-low input. Chip select from the master for the SPI Interface.
16	SCLK	I	Serial clock output from the master for the SPI Interface
17	SI	I	Serial data input for the SPI Interface.
18	SO	O	Serial data output for the SPI Interface
19	V _{DD}	P	3.3 V to 5.0 V logic supply for the SPI communication. The SPI I/Os are not fail-safe protected: V _{DD} needs to be present during any SPI traffic to avoid excessive leakage currents and corrupted SPI I/O logic levels.
20	CAP_A	I/O	External capacitor connection for the analog LDO. Use capacitance value of 100nF.
21	RESET	I	Keep RESET low for normal operation and drive RESET high and release it to perform a hardware reset of the device. The RESET pin is connected to ground via a 1M Ω pull-down resistor. If not used, the RESET pin shall be grounded to avoid any accidental device reset due to coupled noise onto this pin.
22	CAP_Pre	I/O	External capacitor connection for the pre-regulator. Use capacitance value of 1 μ F.
23	CAP_D	I/O	External capacitor connection for the digital LDO. Use capacitance value of 100nF.
24	$\overline{\text{INT}}$	O	Open drain output. Pulled low (internally) upon change of state on the input or occurrence of a special event.
25	IN2	I/O	Ground/V _{BAT} switch monitoring input with configurable current sink or source.
26	IN3	I/O	Ground/V _{BAT} switch monitoring input with configurable current sink or source.
27	IN4	I/O	Ground/V _{BAT} switch monitoring input with configurable current sink or source.
28	DGND	P	Ground for digital circuitry
29	IN5	I/O	Ground/V _{BAT} switch monitoring input with configurable current sink or source.
30	IN6	I/O	Ground/V _{BAT} switch monitoring input with configurable current sink or source.
31	IN7	I/O	Ground/V _{BAT} switch monitoring input with configurable current sink or source.
32	IN8	I/O	Ground/V _{BAT} switch monitoring input with configurable current sink or source.
33	IN9	I/O	Ground/V _{BAT} switch monitoring input with configurable current sink or source.
34	IN10	I/O	Ground switch monitoring input with current source
35	IN11	I/O	Ground switch monitoring input with current source
36	IN12	I/O	Ground switch monitoring input with current source
37	V _S	P	Power supply input pin.
38	V _S	P	Power supply input pin.
---	EP	P	Exposed Pad. The exposed pad is not electrically connected to AGND or DGND. Connect EP to the board ground to achieve rated thermal and ESD performance.

6 Specifications

6.1 Absolute Maximum Ratings

over operating free-air temperature range (unless otherwise noted)⁽¹⁾

		MIN	MAX	UNIT
Input voltage	V_S, \overline{INT}	-0.3	40 ⁽²⁾	V
	$V_{DD}, SCLK, SI, SO, \overline{CS}, RESET$	-0.3	6	V
	IN0- IN23	-24	40 ⁽²⁾	V
	CAP_Pre	-0.3	5.5	V
	CAP_A	-0.3	5.5	V
	CAP_D	-0.3	2	V
Operating junction temperature, T_J		-40	150	°C
Storage temperature, T_{stg}		-55	155	°C

- (1) Stresses beyond those listed under *Absolute Maximum Ratings* may cause permanent damage to the device. These are stress ratings only, which do not imply functional operation of the device at these or any other conditions beyond those indicated under *Recommended Operating Conditions*. Exposure to absolute-maximum-rated conditions for extended periods may affect device reliability.
- (2) Tested for load dump and jump start conditions with nominal operating voltage no greater than 16V for the life of a 12-V automotive system. Refer to [Using TIC10024-Q1 in a 12 V Automotive System](#) for more details.

6.2 ESD Ratings

			VALUE	UNIT	
$V_{(ESD)}$	Electrostatic discharge	Human-body model (HBM), per AEC Q100-002 ⁽¹⁾	All pins	±2000	V
			Pins IN0-IN23 ⁽²⁾	±4000	
		Charged-device model (CDM), per AEC Q100-011	All pins	±500	
			Corner pins (pin 1, 19, 20 and 38)	±750	
		Contact discharge, un-powered, per ISO- 10605 ⁽³⁾⁽⁴⁾	Pins IN0-IN23	±8000	
		Contact discharge, powered-up, per ISO- 10605 ⁽⁵⁾⁽⁶⁾	Pins IN0-IN23	±8000	

- (1) AEC Q100-002 indicates that HBM stressing shall be in accordance with the ANSI/ESDA/JEDEC JS-001 specification.
- (2) ±4kV rating on pins IN0-IN23 are stressed with respect to GND (with AGND, DGND, and EP tied together).
- (3) External components: capacitor = 15 nF; resistor = 10 Ω
- (4) ESD generator parameters: storage capacitance = 150 pF; discharge resistance = 330 Ω or 2000 Ω
- (5) External components: capacitor = 15 nF; resistor = 33 Ω
- (6) ESD generator parameters: storage capacitance = 150 pF or 330pF; discharge resistance = 330 Ω or 2000 Ω

6.3 Recommended Operating Conditions

over operating free-air temperature range and $V_S = 12$ V (unless otherwise noted)

		MIN	NOM	MAX	UNIT
V_S	Power supply voltage	4.5		35 ⁽¹⁾	V
V_{DD}	Logic supply voltage	3.0		5.5	V
$V_{/INT}$	\overline{INT} pin voltage	0		35 ⁽¹⁾	V
V_{INX}	IN0 to IN23 input voltage	0		35 ⁽¹⁾	V
V_{RESET}	RESET pin voltage	0		5.5	V
V_{SPL_IO}	SPI input/output logic level	0		V_{DD}	V
f_{SPI}	SPI communication frequency	20 ⁽²⁾		4M	Hz
T_A	Operating free-air temperature	-40		125	°C

- (1) Tested for load dump and jump start conditions with nominal operating voltage no greater than 16 V for the life of a 12-V automotive system. Refer to [Using TIC10024-Q1 in a 12 V Automotive System](#) for more details.
- (2) Lowest frequency characterized.

6.4 Thermal Information

THERMAL METRIC ⁽¹⁾		TIC10024-Q1	
		DCP (TSSOP)	UNIT
		38 PINS	
R _{θJA}	Junction-to-ambient thermal resistance	33.6	°C/W
R _{θJC(top)}	Junction-to-case (top) thermal resistance	18.4	°C/W
R _{θJB}	Junction-to-board thermal resistance	15.2	°C/W
ψ _{JT}	Junction-to-top characterization parameter	0.5	°C/W
ψ _{JB}	Junction-to-board characterization parameter	15.0	°C/W
R _{θJC(bot)}	Junction-to-case (bottom) thermal resistance	1.2	°C/W

(1) For more information about traditional and new thermal metrics, see the [Semiconductor and IC Package Thermal Metrics](#) application report.

6.5 Electrical Characteristics

over operating free-air temperature range, V_S = 4.5 V to 35 V, and V_{DD} = 3 V to 5.5 V (unless otherwise noted)

PARAMETER		TEST CONDITIONS		MIN	TYP	MAX	UNIT
POWER SUPPLY							
I _{S_CONT}	Continuous mode V _S power supply current	Continuous mode, I _{WETT} = 10 mA, all switches open, no active comparator operation, no unserviced interrupt			5.6	7	mA
I _{S_POLL_COMP_25}	Polling mode V _S power supply average current	T _A = 25°	Polling mode, t _{POLL} = 64 ms, t _{POLL_ACT} = 128 μs, all switches open, I _{WETT} = 10 mA, no unserviced interrupt		68	100	μA
I _{S_POLL_COMP_85}		T _A = -40° to 85°C			68	110	μA
I _{S_POLL_COMP}		T _A = -40° to 125°C			68	170	μA
I _{S_RESET}	Reset mode V _S power supply current	Reset mode, V _{RESET} = V _{DD} . V _S = 12 V, all switches open, T _A = 25°C			12	17	μA
I _{S_IDLE_25}	V _S power supply average current in idle state	TRIGGER bit in CONFIG register = logic 0, T _A = 25°C, no unserviced interrupt			50	75	μA
I _{S_IDLE_85}		TRIGGER bit in CONFIG register = logic 0, T _A = -40°C to 85°C, no unserviced interrupt			50	95	μA
I _{S_IDLE}		TRIGGER bit in CONFIG register = logic 0, T _A = -40°C to 125°C, no unserviced interrupt			50	145	μA
I _{DD}	Logic supply current from V _{DD}	SCLK = SI = 0 V, $\overline{CS} = \overline{INT} = V_{DD}$, no SPI communication			1.5	10	μA
V _{POR_R}	Power on reset (POR) voltage for V _S	Threshold for rising V _S from device OFF condition resulting in \overline{INT} pin assertion and a flagged POR bit in the INT_STAT register		3.85		4.5	V
V _{POR_F}		Threshold for falling V _S from device normal operation to reset mode and loss of SPI communication		1.95		2.8	V
V _{OV_R}	Over-voltage (OV) condition for V _S	Threshold for rising V _S from device normal operation resulting in \overline{INT} pin assertion and a flagged OV bit in the INT_STAT register		35		40	V
V _{OV_HYST}	Over-voltage (OV) condition hysteresis for V _S			1		3.5	V
V _{UV_R}	Under-voltage (UV) condition for V _S	Threshold for rising V _S from under-voltage condition resulting in \overline{INT} pin assertion and a flagged UV bit in the INT_STAT register		3.85		4.5	V
V _{UV_F}		Threshold for falling V _S from under-voltage condition resulting in \overline{INT} pin assertion and a flagged UV bit in the INT_STAT register		3.7		4.4	V
V _{UV_HYST}	Under-voltage (UV) condition hysteresis for V _S ⁽¹⁾			75		275	mV
V _{DD_F}		Threshold for falling V _{DD} resulting in loss of SPI communication		2.5		2.9	V
V _{DD_HYST}	Valid V _{DD} voltage hysteresis			50		150	mV

(1) Specified by design.

Electrical Characteristics (continued)

over operating free-air temperature range, $V_S = 4.5\text{ V to }35\text{ V}$, and $V_{DD} = 3\text{ V to }5.5\text{ V}$ (unless otherwise noted)

PARAMETER		TEST CONDITIONS		MIN	TYP	MAX	UNIT
WETTING CURRENT ACCURACY (DIGITAL SWITCHES, MAXIMUM RESISTANCE VALUE WITH SWITCH CLOSED $\leq 100\Omega$, MINIMUM RESISTANCE VALUE WITH SWITCH OPEN $\geq 5000\Omega$)							
I_{WETT} (CSO)	Wetting current accuracy for CSO (switch closed)	1 mA setting	$4.5\text{ V} \leq V_S \leq 35\text{ V}$	0.84	1	1.14	mA
		2 mA setting		1.71	2	2.32	
		5 mA setting	$4.5\text{ V} \leq V_S < 5\text{ V}$	2.39		5.5	
			$5\text{ V} \leq V_S \leq 35\text{ V}$	4.3	5	5.6	
		10 mA setting	$4.5\text{ V} \leq V_S < 6\text{ V}$	2.4		11	
			$6\text{ V} \leq V_S \leq 35\text{ V}$	8.4	10	11.4	
15 mA setting	$4.5\text{ V} \leq V_S < 6.5\text{ V}$	2.4		16.5			
	$6.5\text{ V} \leq V_S \leq 35\text{ V}$	12.5	15	17			
I_{WETT} (CSI)	Wetting current accuracy for CSI (switch closed)	1 mA setting	$4.5\text{ V} \leq V_S \leq 35\text{ V}$	0.75	1.1	2.05	mA
		2 mA setting		1.6	2.2	3.3	
		5 mA setting		4.3	5.6	7.1	
		10 mA setting		9.2	11.5	13.4	
		15 mA setting	$4.5\text{ V} \leq V_S < 6\text{ V}$	11	16.5	19.2	
$6\text{ V} \leq V_S \leq 35\text{ V}$	13.7		16.5	19.2			
$V_{CSL_DROP_OPEN}$	Voltage drop from IN_x pin to AGND across CSI (switch open)	10 mA setting, $R_{SW} = 5k\Omega$	$4.5\text{ V} \leq V_S \leq 35\text{ V}$			1.7	V
		15 mA setting, $R_{SW} = 5k\Omega$				1.7	
$V_{CSL_DROP_CLOSED}$	Voltage drop from IN_x pin to ground across CSI (switch closed)	2mA setting, $I_{IN} = 1\text{mA}$ ($4.5\text{ V} \leq V_S \leq 35\text{ V}$)	$4.5\text{ V} \leq V_S \leq 35\text{ V}$			1.2	V
		5mA setting, $I_{IN} = 1\text{mA}$ or 2mA				1.3	V
		10mA setting, $I_{IN} = 1\text{mA}$, 2mA, or 5mA				1.5	V
		15mA setting, $I_{IN} = 1\text{mA}$, 2mA, 5mA, or 10mA				2.1	V
LEAKAGE CURRENTS							
$I_{IN_LEAK_OFF}$	Leakage current at input IN_x when channel is disabled	$0\text{ V} \leq V_{INx} \leq V_S$, channel disabled (EN_INx register bit= logic 0)		-4			μA
$I_{IN_LEAK_OFF_25}$		$0\text{ V} \leq V_{INx} \leq V_S$, channel disabled (EN_INx register bit= logic 0), $T_A = 25^\circ\text{C}$		-0.5	0.5		
$I_{IN_LEAK_0mA}$	Leakage current at input IN_x when wetting current setting is 0mA	$0\text{ V} \leq V_{INx} \leq 6\text{ V}$, $6\text{ V} \leq V_S \leq 35\text{ V}$, I_{WETT} setting = 0 mA		-110	110		μA
$I_{IN_LEAK_LOSS_OF_GND}$	Leakage current at input IN_x under loss of GND condition	$V_S = 24\text{ V}$, $0\text{ V} \leq V_{INx} \leq 24\text{ V}$, all grounds (AGND, DGND, and EP) = 24 V, V_{DD} shorted to the grounds ⁽¹⁾		-5			μA
$I_{IN_LEAK_LOSS_OF_VS}$	Leakage current at input IN_x under loss of V_S condition	$0\text{ V} \leq V_{INx} \leq 24\text{ V}$, V_S shorted to the grounds = 0 V, $V_{DD} = 0\text{ V}$				5	μA
LOGIC LEVELS							
V_{INT_L}	\overline{INT} output low voltage	$I_{INT} = 2\text{ mA}$				0.35	V
		$I_{INT} = 4\text{ mA}$				0.6	
V_{SO_L}	SO output low voltage	$I_{SO} = 2\text{ mA}$				$0.2V_{DD}$	V
V_{SO_H}	SO output high voltage	$I_{SO} = -2\text{ mA}$		$0.8V_{DD}$		V	
V_{IN_L}	SI, SCLK, and \overline{CS} input low voltage			$0.3V_{DD}$		V	
V_{IN_H}	SI, SCLK, and \overline{CS} input high voltage			$0.7V_{DD}$		V	
V_{RESET_L}	RESET input low voltage					0.8	V

Electrical Characteristics (continued)

 over operating free-air temperature range, $V_S = 4.5\text{ V to }35\text{ V}$, and $V_{DD} = 3\text{ V to }5.5\text{ V}$ (unless otherwise noted)

PARAMETER		TEST CONDITIONS	MIN	TYP	MAX	UNIT
$V_{\text{RESET_H}}$	RESET input high voltage		1.6			V
$R_{\text{RESET_25}}$	RESET pin internal pull-down resistor	$V_{\text{RESET}} = 0\text{ to }5.5\text{ V}$, $T_A = 25^\circ\text{C}$	0.85	1.25	1.7	M Ω
R_{RESET}		$V_{\text{RESET}} = 0\text{ to }5.5\text{ V}$, $T_A = -40^\circ\text{ to }125^\circ\text{C}$	0.2		2.1	
COMPARATOR PARAMETERS						
$V_{\text{TH_COMP_2V}}$	Comparator threshold for 2 V	THRES_COMP = 2 V	1.85		2.25	V
$V_{\text{TH_COMP_2p7V}}$	Comparator threshold for 2.7 V	THRES_COMP = 2.7 V	2.4		2.9	V
$V_{\text{TH_COMP_3V}}$	Comparator threshold for 3 V	THRES_COMP = 3 V	2.85		3.3	V
$V_{\text{TH_COMP_4V}}$	Comparator threshold for 4 V	THRES_COMP = 4 V	3.7		4.35	V
$V_{\text{S_COMP}}$	Minimum V_S requirement for proper detection	THRES_COMP = 2 V	4.5			V
		THRES_COMP = 2.7 V	5			
		THRES_COMP = 3 V	5.5			
		THRES_COMP = 4 V	6.5			
$R_{\text{IN_COMP}}$	Comparator equivalent input resistance	THRES_COMP = 2 V	30	130		k Ω
		THRES_COMP = 2.7 V	35	130		
		THRES_COMP = 3 V	35	105		
		THRES_COMP = 4 V	43	95		

6.6 Timing Requirements

$V_S = 4.5\text{ V to }35\text{ V}$, $V_{DD} = 3\text{ V to }5.5\text{ V}$, and 10 pF capacitive load on SO unless otherwise noted; verified by design and characterization

		MIN	NOM	MAX	UNIT	
SWITCH MONITORING, INTERRUPT, STARTUP AND RESET						
$t_{\text{POLL_ACT}}$	Polling active time accuracy	Polling mode		-12%	12%	
t_{POLL}	Polling time accuracy	Polling mode		-12%	12%	
t_{COMP}	Comparator detection time	18			μs	
$t_{\text{CCP_TRAN}}$	Transition time between last input sampling and start of clean current	20			μs	
$t_{\text{CCP_ACT}}$	Clean current active time	-12%		12%		
t_{STARTUP}	Polling startup time	200	300	400	μs	
$t_{\text{INT_ACTIV E}}$	Active $\overline{\text{INT}}$ assertion duration	1.5	2	2.5	ms	
$t_{\text{INT_INACT IVE}}$	$\overline{\text{INT}}$ de-assertion duration during a pending interrupt	3	4	5	ms	
$t_{\text{INT_IDLE}}$	Interrupt idle time	80	100	120	μs	
t_{RESET}	Time required to keep the RESET pin high to successfully reset the device (no pending interrupt) ⁽¹⁾	2			μs	
t_{REACT}	Delay between a fault event (OV, UV, TW, or TSD) to a high to low transition on the $\overline{\text{INT}}$ pin	See Figure 5 for OV example.		20	μs	
SPI INTERFACE						
t_{LEAD}	Falling edge of $\overline{\text{CS}}$ to rising edge of SCLK setup time	100			ns	
t_{LAG}	Falling edge of SCLK to rising edge of $\overline{\text{CS}}$ setup time	100			ns	
t_{SU}	SI to SCLK falling edge setup time	30			ns	
t_{HOLD}	SI hold time after falling edge of SCLK	20			ns	
t_{VALID}	Time from rising edge of SCLK to valid SO data	70			ns	
$t_{\text{SO(EN)}}$	Time from falling edge of $\overline{\text{CS}}$ to SO low-impedance	60			ns	
$t_{\text{SO(DIS)}}$	Time from rising edge of $\overline{\text{CS}}$ to SO high-impedance	Loading of 1 k Ω to GND. See Figure 6.		60	ns	
t_{R}	SI, $\overline{\text{CS}}$, and SCLK signals rise time	5			30	ns
t_{F}	SI, $\overline{\text{CS}}$, and SCLK signals fall time	5			30	ns
$t_{\text{INTER_FR AME}}$	Delay between two SPI communication ($\overline{\text{CS}}$ low) sequences	1.5			μs	
t_{CKH}	SCLK High time	120			ns	
t_{CKL}	SCLK Low time	120			ns	
$t_{\text{INITIATION}}$	Delay between valid V_{DD} voltage and initial SPI communication	45			μs	

(1) If there is a pending interrupt ($\overline{\text{INT}}$ pin asserted low), it can take up to 1ms for the device to complete the reset.

6.7 Typical Characteristics

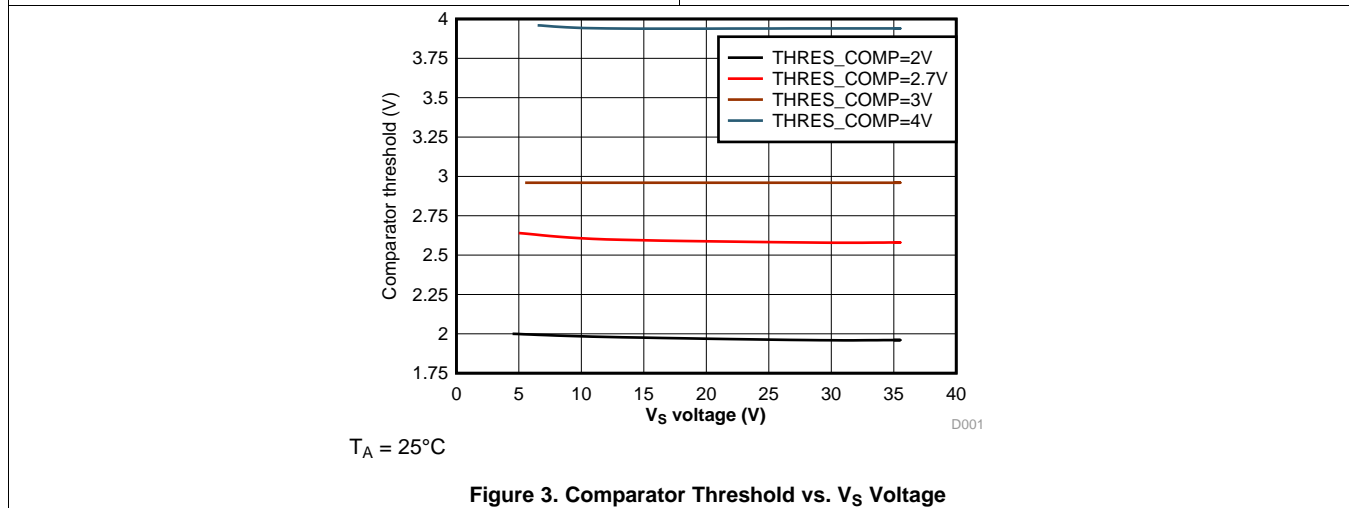
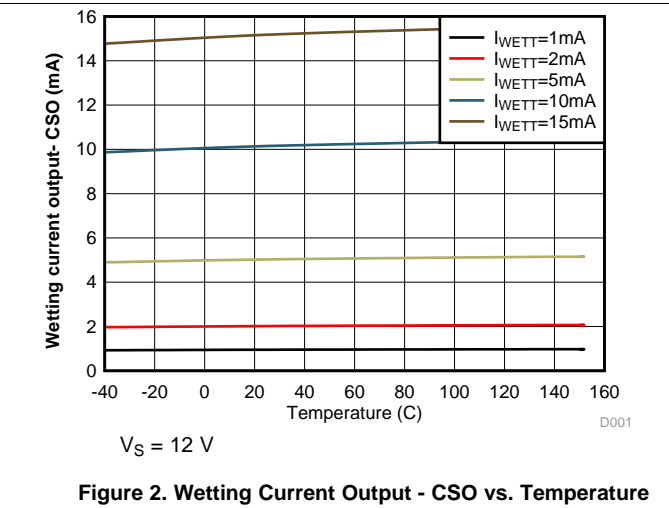
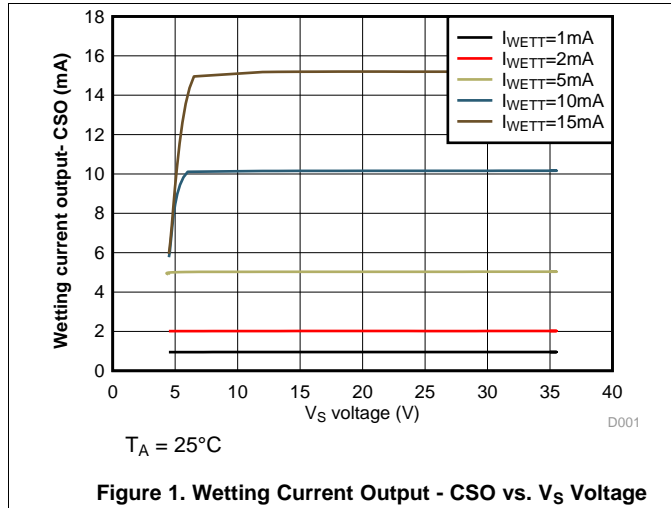

7 Parameter Measurement Information

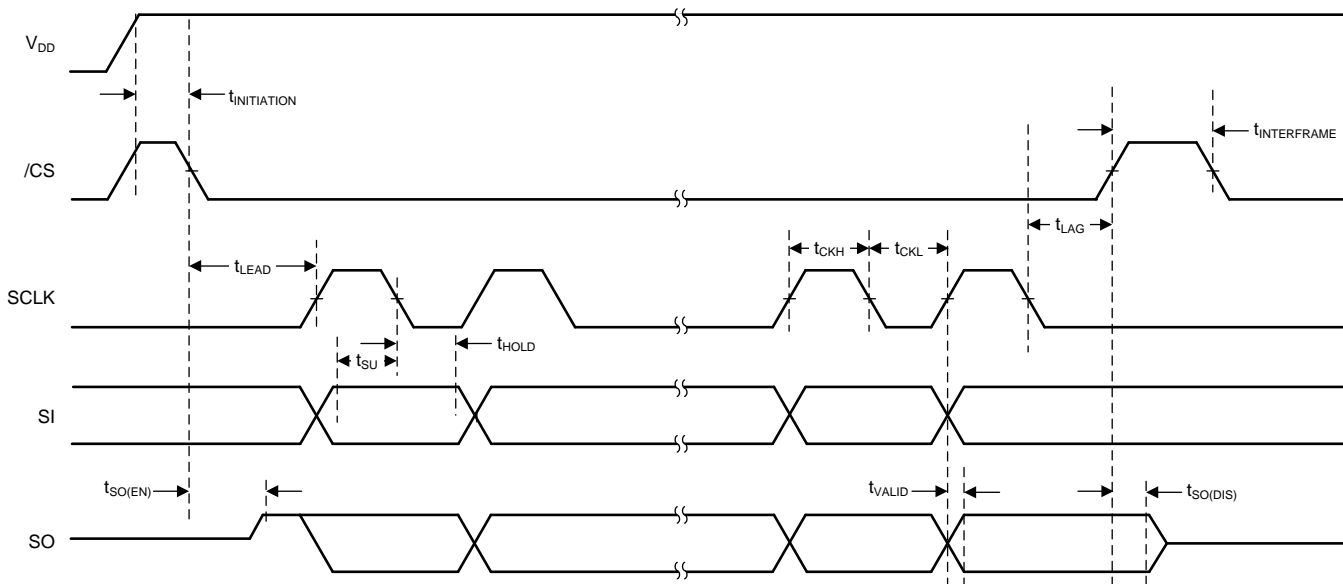

Figure 4. SPI Timing Parameters

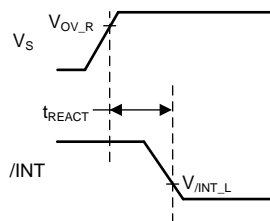

Figure 5. t_{REACT} Timing Parameters

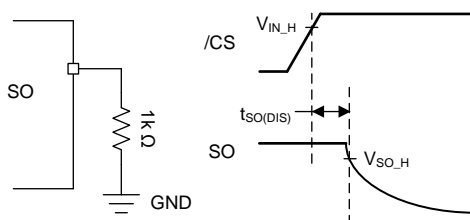

Figure 6. $t_{SO(DIS)}$ Timing Parameters

8 Detailed Description

8.1 Overview

The TIC10024-Q1 is an advanced 24-input Multiple Switch Detection Interface (MSDI) device designed to detect external mechanical switch status in a 12-V automotive system by acting as an interface between the switches and the low-voltage microcontroller. The TIC10024-Q1 is an integrated solution that replaces many discrete components and provides integrated protection, input serialization, and system wake-up capability.

The device monitors 14 switches to GND and 10 additional switches that can be programmed to be connected to either GND or V_{BAT} . It features SPI interface to report individual switch status and provides programmability to control the device operation. The TIC10024-Q1 features an integrated comparator that can be used to monitor external digital switch input status. The device has 2 modes of operation: continuous mode and polling mode. The polling mode is a low-power mode that can be activated to reduce current drawn in the system by only turning on the wetting current for a small duty cycle to detect switch status changes. An interrupt is generated upon detection of switch status change and it can be used to wake up the microcontroller to bring the entire system back to operation.

8.2 Functional Block Diagram

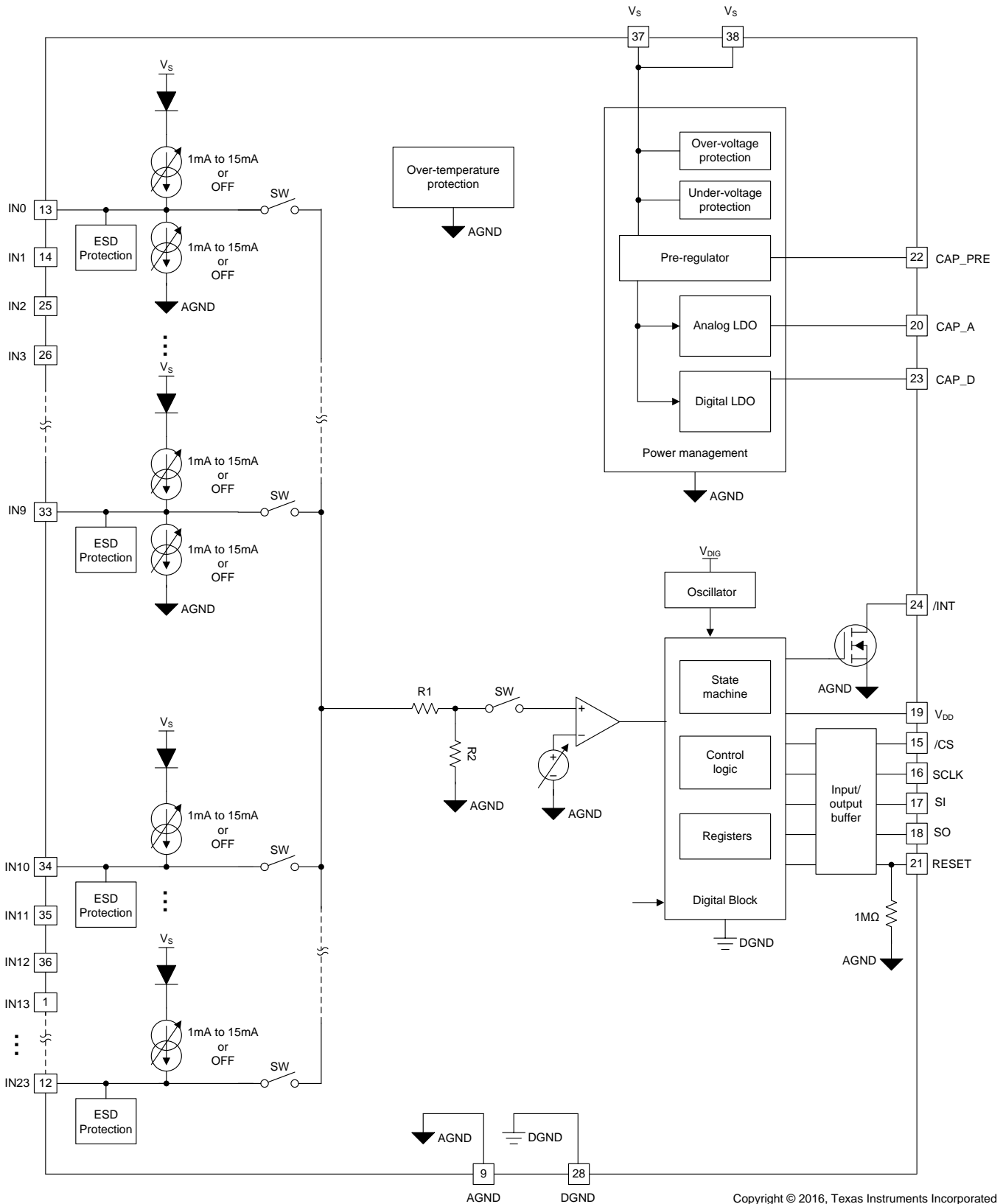

Copyright © 2016, Texas Instruments Incorporated

8.3 Feature Description

8.3.1 V_S Pin

The V_S supply provides power to the entire chip and it is designed to be connected directly to a 12-V automotive battery via a reverse-polarity blocking diode.

8.3.2 V_{DD} Pin

The V_{DD} supply is used to determine the logic level on the SPI communication interface, source the current for the SO driver, and sets the pull-up voltage for the \overline{CS} pin. It can also be used as a possible external pull-up supply for the INT pin in addition to the V_S and it shall be connected to a 3 V to 5.5-V logic supply. Removing V_{DD} from the device disables SPI communications but does not reset the register configurations.

8.3.3 Device Initialization

When the device is powered up for the first time, the condition is called Power-On Reset (POR), which sets the registers to their default values and initializes the device state machine. The internal POR controller holds the device in a reset condition until V_S has reached V_{POR_R} , at which the reset condition is released with the device registers and state machine initialized to their default values. After the initialization process is completed, the INT pin is asserted low to notify the microcontroller, and the register bit POR in the INT_STAT register is asserted to logic 1. The SPI flag bit POR is also asserted at the SPI output (SO).

During device initialization, factory settings are programmed into the device to allow accurate device operation. The device performs a self-check after the device is programmed to ensure correct settings are loaded. If the self-check returns an error, the CHK_FAIL bit in the INT_STAT register will be flagged to logic 1 along with the POR bit. If this event occurs the microcontroller is recommended to initiate software reset (see section [Software Reset](#)) to re-initialize the device to allow the correct settings to be re-programmed.

8.3.4 Device Trigger

After device initialization, the TIC10024-Q1 is ready to be configured. The microcontroller can use SPI commands to program desired settings to the configuration registers. Once the device configuration is completed, the microcontroller is required to set the bit TRIGGER in the CONFIG register to logic 1 in order to activate wetting current and start external switch monitoring.

After switch monitoring initiates, the configuration registers turn into read-only registers (with the exception of the TRIGGER, CRC_T, and RESET bits in the CONFIG register and all bits in the CCP_CFG1 register). If at any time the device setting needs to be re-configured, the microcontroller is required to first set the bit TRIGGER in the CONFIG register to logic 0 to stop wetting current and switch monitoring. The microcontroller can then program configuration registers to the desired settings. Once the re-configuration is completed the microcontroller can set the TRIGGER bit back to logic 1 to re-start switch monitoring.

Note the cyclic redundancy check (CRC) feature stays accessible when TRIGGER bit is in logic 1, allowing the microcontroller to verify device settings at all time. Refer to section [Cyclic Redundancy Check \(CRC\)](#) for more details of the CRC feature.

8.3.5 Device Reset

There are 3 ways to reset the TIC10024-Q1 and re-initialize all registers to their default values:

8.3.5.1 V_S Supply POR

The device is turned off and all register contents are lost if the V_S voltage drops below V_{POR_F} . To turn the device back on, the V_S voltage must be raised back above V_{POR_R} , as illustrated in [Figure 7](#). The device then starts the initialization process as described in section [Device Initialization](#).

Feature Description (continued)

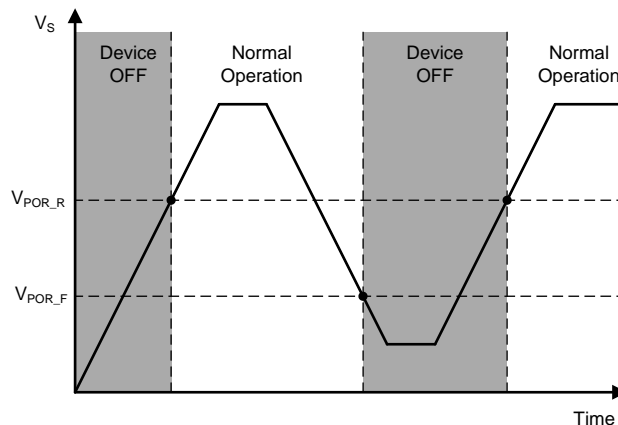

Figure 7. V_S is Lowered Below The POR threshold, Then Ramped Back Up To Complete A POR Cycle

8.3.5.2 Hardware Reset

Microcontroller can toggle the RESET pin to perform a hardware reset to the device. The RESET pin is internally pulled-down via a resistor (1.25M Ω typical) and must be kept low for normal operation. When the RESET pin is toggled high, the device enters the reset state with most of the internal blocks turned off and consumes very little current of I_{S_RESET} . Switch monitoring and SPI communications are stopped in the reset state, and all register contents are cleared. When RESET pin is toggled back low, all the registers are set to their default values and the device state machine is re-initialized, similar to a POR event. When the re-initialization process is completed the \overline{INT} pin is asserted low, and the interrupt register bit POR and the SPI status flag POR are both asserted to notify the microcontroller that the device has completed the reset process.

Note in order to successfully reset the device, the RESET pin needs to be kept high for a minimum duration of t_{RESET} . The pin is required to be driven with a stable input (below V_{RESET_L} for logic low or above V_{RESET_H} for logic H) to prevent the device from accidental reset.

8.3.5.3 Software Reset

In addition to hardware reset the microcontroller can also issue a SPI command to initiate software reset. Software reset is triggered by setting the RESET bit in the register CONFIG to logic 1, which re-initializes the device with all registers set to their default values. Once the re-initialization process is completed, the \overline{INT} pin is asserted low, and the interrupt register bit POR and the SPI status flag POR are both asserted to notify the microcontroller that the device has completed the reset process.

8.3.6 V_S Under-Voltage (UV) Condition

During normal operation of a typical 12V automotive system, the V_S voltage is usually quite stable and stays well above 11 V. However, the V_S voltage might drop temporarily during certain vehicle operations, such as cold cranking. If the V_S voltage drops below V_{UV_F} , the TIC10024-Q1 enters the under-voltage (UV) condition since there is not enough voltage headroom for the device to accurately generate wetting currents. The following describes the behavior of the TIC10024-Q1 under UV condition:

1. All current sources/sinks de-activate and switch monitoring stops.
2. Interrupt is generated by asserting the \overline{INT} pin low and the bit UV in the interrupt register (INT_STAT) is flagged to logic 1. The bit UV_STAT is asserted to logic 1 in the register IN_STAT_MISC. The OI SPI flag is asserted during any SPI transactions. The \overline{INT} pin is released and the interrupt register (INT_STAT) is cleared on the rising edge of \overline{CS} provided that the interrupt register has been read during the SPI transaction.
3. SPI communication stays active, and all register settings stay intact without resetting. Previous switch status, if needed, can be retrieved without interruption.
4. The device continues to monitor the V_S voltage, and the UV condition sustains if the V_S voltage continues to stay below V_{UV_R} . No further interrupt is generated once cleared.

Feature Description (continued)

Note the device resets as described in section [VS Supply POR](#) if the V_S voltage drops below V_{POR_F} .

When the V_S voltage rises above V_{UV_R} , the \overline{INT} pin is asserted low to notify the microcontroller that the UV condition no longer exists. The UV bit in the register INT_STAT is flagged to logic 1 and the bit UV_STAT bit is de-asserted to logic 0 in the register IN_STAT_MISC to reflect the clearance of the UV condition. The device resumes operation using current register settings (regardless of the \overline{INT} pin and SPI communication status) with polling restarted from the first enabled channel. The Switch State Change (SSC) interrupt is generated at the end of the first polling cycle and the detected switch status becomes the baseline switch status for subsequent polling cycles. The content of the INT_STAT register, once read by the microcontroller, is cleared, and the \overline{INT} pin is released afterwards.

The following diagram describes the TIC10024-Q1 operation at various different V_S voltages. If the V_S voltage stays above V_{UV_F} (Case 1), the device stays in normal operation. If the V_S voltage drops below V_{UV_F} but stays above V_{POR_F} (Case 2), the device enters the UV condition. If V_S voltage drops below V_{POR_F} (Case 3), the device resets and all register settings are cleared. The microcontroller is then required to re-program all the configuration registers in order to resume normal operation after the V_S voltage recovers.

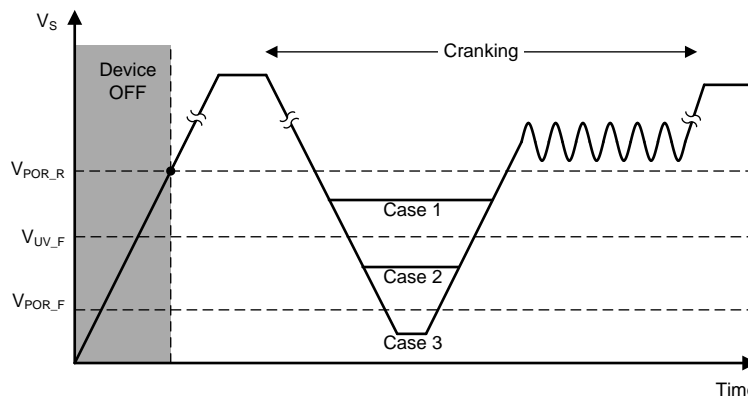

Figure 8. TIC10024-Q1 Operation At Various V_S Voltage Levels

8.3.7 V_S Over-Voltage (OV) Condition

If V_S voltage rises above V_{OV_R} , the TIC10024-Q1 enters the over-voltage (OV) condition to prevent damage to internal structures of the device on the V_S and INx (for battery-connected switches) pins. The following describes the behavior of the TIC10024-Q1 under OV condition:

1. All current sources/sinks de-activate and switch monitoring stops.
2. Interrupt is generated by asserting the \overline{INT} pin low and the bit OV in the interrupt register (INT_STAT) is flagged to logic 1. The bit OV_STAT is asserted to logic 1 in the register IN_STAT_MISC. The OI SPI flag is asserted during any SPI transactions. The \overline{INT} pin is released and the interrupt register (INT_STAT) is cleared on the rising edge of \overline{CS} provided that the interrupt register has been read during the SPI transaction.
3. SPI communication stays active, and all register settings stay intact without resetting. Previous switch status, if needed, can be retrieved without any interruption.
4. The device continues to monitor the V_S voltage, and the OV condition sustains if the V_S voltage continues to stay above $V_{OV_R} - V_{OV_HYST}$. No further interrupt is generated once cleared.

When the V_S voltage drops below $V_{OV_R} - V_{OV_HYST}$, the \overline{INT} pin is asserted low to notify the microcontroller that the over-voltage condition no longer exists. The OV bit in the register INT_STAT is flagged to logic 1 and the bit OV_STAT bit is de-asserted to logic 0 in the register IN_STAT_MISC to reflect the clearance of the OV condition. The device resumes operation using current register settings (regardless of the \overline{INT} pin and SPI communication status) with polling restarted from the first enabled channel. The Switch State Change (SSC) interrupt is generated at the end of the first polling cycle and the detected switch status becomes the baseline status for subsequent polling cycles. The content of the INT_STAT register, once read by the microcontroller, is cleared and the \overline{INT} pin is released afterwards.

Feature Description (continued)

8.3.8 Switch Inputs Settings

IN0 to IN23 are inputs connected to external mechanical switches. The switch status of each input, whether open or closed, is indicated by the status registers. [Table 1](#) below describes various settings that can be configured for each input. Note some settings are shared between multiple inputs. It is required to first stop device operation by setting the TRIGGER bit low in the register CONFIG before making any configuration changes, as described in [Device Trigger](#).

Table 1. TIC10024-Q1 Wetting Current and Threshold Setting Details

Input	Threshold	Wetting Current	Current Source (CSO) / Current Sink (CSI)	Supported Switch Type
IN0	THRES_COMP_IN0_IN3	WC_IN0_IN1	CSO	Switch to GND
IN1			CSI	Switch to VBAT
IN2		WC_IN2_IN3	CSO	Switch to GND
IN3			CSI	Switch to VBAT
IN4	THRES_COMP_IN4_IN7	WC_IN4	CSO	Switch to GND
IN5		CSI	Switch to VBAT	
IN6		WC_IN6_IN7	CSO	Switch to GND
IN7			CSI	Switch to VBAT
IN8	THRES_COMP_IN8_IN11	WC_IN8_IN9	CSO	Switch to GND
IN9			CSI	Switch to VBAT
IN10		WC_IN10	CSO	Switch to GND
IN11		WC_IN11	CSO	Switch to GND
IN12	THRES_COMP_IN12_IN15	WC_IN12_13	CSO	Switch to GND
IN13			CSO	Switch to GND
IN14		WC_IN14_15	CSO	Switch to GND
IN15			CSO	Switch to GND
IN16	THRES_COMP_IN16_IN19	WC_IN16_17	CSO	Switch to GND
IN17			CSO	Switch to GND
IN18		WC_IN18_19	CSO	Switch to GND
IN19			CSO	Switch to GND
IN20	THRES_COMP_IN20_IN23	WC_IN20_21	CSO	Switch to GND
IN21			CSO	Switch to GND
IN22		WC_IN22	CSO	Switch to GND
IN23		WC_IN23	CSO	Switch to GND

8.3.8.1 Input Current Source/Sink Selection

Among the 24 inputs, IN10 to IN23 are intended for monitoring only ground-connected switches and are connected to current sources. IN0 to IN9 can be programmed to monitor either ground-connected switches or battery-connected switches by configuring the [CS_SELECT](#) register. The default configuration of the IN0-IN9 inputs after POR is to monitor ground-connected switches (current sources are selected). To set an input to monitor battery-connected switches, set the corresponding bit to logic 1.

8.3.8.2 Input Enable Selection

The TIC10024-Q1 provides switch status monitoring for up to 24 inputs, but there might be circumstances in which not all inputs need to be constantly monitored. The microcontroller may choose to enable/disable monitoring of certain inputs by configuring the `IN_EN` register. Setting the corresponding bit to logic 0 deactivates the wetting current source/sink and stops switch status monitoring for the input. Disabling monitoring of unused inputs reduces overall power consumption of the device.

All inputs are disabled by default upon device reset.

8.3.8.3 Thresholds Adjustment

The threshold level for interrupt generation can be programmed by setting the `THRES_COMP` register. The threshold level settings can be set for each individual input groups and each group consists of 4 inputs. Four threshold levels are available: 2V, 2.7V, 3V, and 4V.

Caution should be used when setting up the threshold for switches that are connected externally to the battery as there is a finite voltage drop (as high as $V_{CSL_DROP_OPEN}$ for 10mA and 15mA settings) across the current sinks. Therefore, even for an open switch, then voltage on the IN_x pin can be as high as $V_{CSL_DROP_OPEN}$ and the detection threshold shall be configured above it. It shall also be noted that a lower wetting current sink setting might not be strong enough to pull the IN_x pin close to ground in the presence of a leaky open external switch, as illustrated in the diagram below (see Figure 9). In this example, the external switch, although in the open state, has large leakage current and can be modelled as an equivalent resistor (R_{DIRT}) of 5k Ω . The 2mA current sink is only able to pull the IN_x pin voltage down to 4V, even if the switch is in the open state.

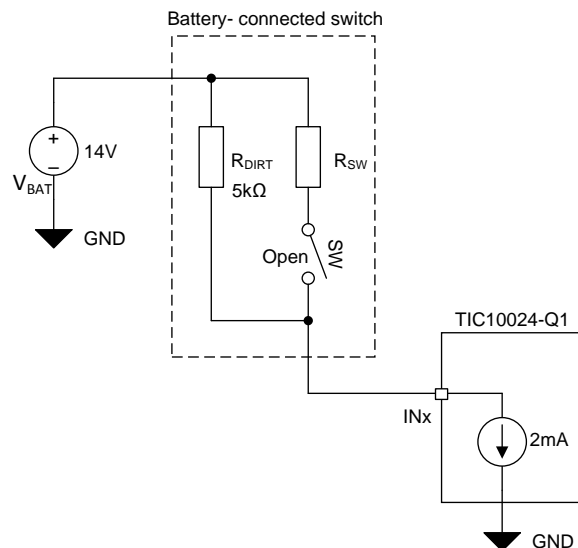

Copyright © 2016, Texas Instruments Incorporated

Figure 9. Example Showing The Calculation of The IN_x Pin Voltage For A Leaky Battery-Connected Switch

8.3.8.4 Wetting Current Configuration

There are 6 different wetting current settings (0 mA, 1 mA, 2 mA, 5 mA, 10 mA, and 15mA) that can be programmed by configuring the `WC_CFG0` and `WC_CFG1` registers. 0 mA is selected by default upon device reset.

The accuracy of the wetting current has stronger dependency on the V_S voltage when V_S voltage is low. The lower the V_S voltage falls, the more deviation on the wetting currents from their nominal values. Refer to $I_{WETT(CSO)}$ and $I_{WETT(CSI)}$ specifications for more details.

8.3.9 Interrupt Generation and $\overline{\text{INT}}$ Assertion

The $\overline{\text{INT}}$ pin is an active-low, open-drain output that asserts low when an event (switch input state change, temperature warning, over-voltage shutdown...etc) is detected by the TIC10024-Q1. An external pull-up resistor to V_{DD} is needed on the $\overline{\text{INT}}$ pin (see Figure 10). The $\overline{\text{INT}}$ pin can also be connected directly to a 12-V automotive battery to support the microcontroller wake-up feature, as describe in section [Microcontroller Wake-Up](#).

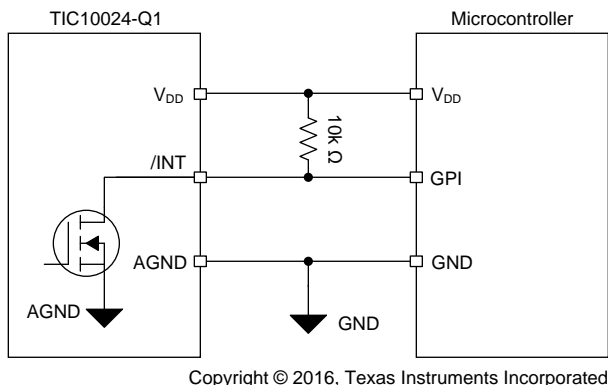

Figure 10. $\overline{\text{INT}}$ Connection Example #1

8.3.9.1 $\overline{\text{INT}}$ Pin Assertion Scheme

TIC10024-Q1 supports two configurable schemes for $\overline{\text{INT}}$ assertion: static and dynamic. The scheme can be adjusted by configuring the INT_CONFIG bit in the CONFIG register.

If the static $\overline{\text{INT}}$ assertion scheme is used (INT_CONFIG = 0 in the CONFIG register), the $\overline{\text{INT}}$ pin is asserted low upon occurrence of an event. The $\overline{\text{INT}}$ pin is released on the rising edge of $\overline{\text{CS}}$ only if a READ command has been issued to read the INT_STAT register while $\overline{\text{CS}}$ is low, otherwise the $\overline{\text{INT}}$ will be kept low indefinitely. The content of the INT_STAT interrupt register is latched on the first rising edge of SCLK after $\overline{\text{CS}}$ goes low for every SPI transaction, and the content is cleared upon a READ command issued to the INT_STAT register, as illustrated in Figure 11.

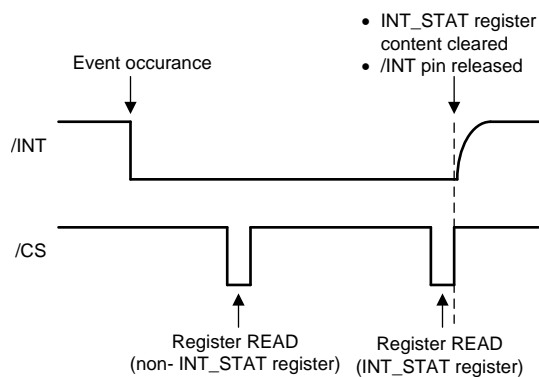

Figure 11. Static $\overline{\text{INT}}$ Assertion Scheme

In some system implementations an edge-triggered based microcontroller might potentially miss the $\overline{\text{INT}}$ assertion if it is configured to the static scheme, especially when the microcontroller is in the process of waking up. To prevent missed $\overline{\text{INT}}$ assertion and improve robustness of the interrupt behavior, the TIC10024-Q1 provides the option to use the dynamic assertion scheme for the $\overline{\text{INT}}$ pin. When the dynamic scheme is used (INT_CONFIG= 1 in the CONFIG register), the $\overline{\text{INT}}$ pin is asserted low for a duration of $t_{\text{INT_ACTIVE}}$ and is de-asserted back to high if the INT_STAT register has not been read after $t_{\text{INT_ACTIVE}}$ has elapsed. The $\overline{\text{INT}}$ is kept high for a duration of $t_{\text{INT_INACTIVE}}$, and is re-asserted low after $t_{\text{INT_INACTIVE}}$ has elapsed. The $\overline{\text{INT}}$ pin continues to toggle until the INT_STAT register is read.

If the INT_STAT register is read when $\overline{\text{INT}}$ pin is asserted low, the $\overline{\text{INT}}$ pin is released on the READ command's $\overline{\text{CS}}$ rising edge and the content of the INT_STAT register is also cleared, as shown in Figure 12. If the INT_STAT register is read when $\overline{\text{INT}}$ pin is de-asserted, the content of the INT_STAT register is cleared on the READ command's $\overline{\text{CS}}$ rising edge, and the $\overline{\text{INT}}$ pin is not re-asserted back low, as shown in Figure 13.

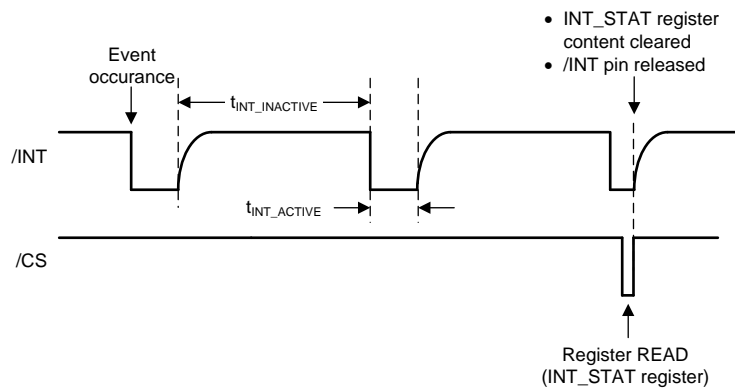

Figure 12. Dynamic $\overline{\text{INT}}$ Assertion Scheme With INT_STAT Register Read During $t_{\text{INT_ACTIVE}}$

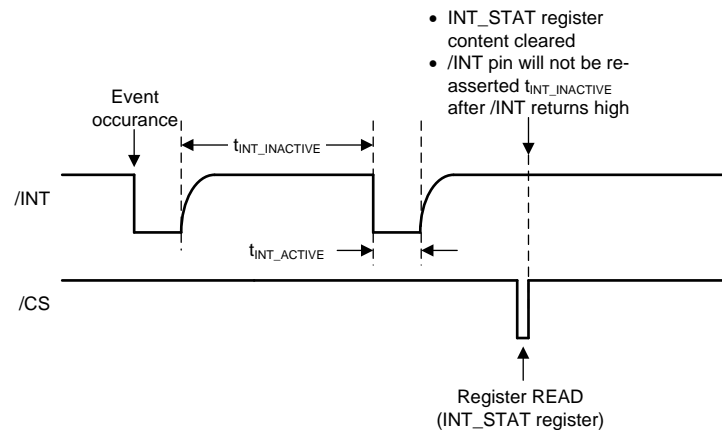

Figure 13. Dynamic $\overline{\text{INT}}$ Assertion Scheme With INT_STAT Register Read During $t_{\text{INT_INACTIVE}}$

The static $\overline{\text{INT}}$ assertion scheme is selected by default upon device reset. The $\overline{\text{INT}}$ pin assertion scheme can only be changed when bit TRIGGER is logic 0 in the CONFIG register.

8.3.9.2 Interrupt Idle Time ($t_{\text{INT_IDLE}}$) Time

Interrupt idle time ($t_{\text{INT_IDLE}}$) is implemented in TIC10024-Q1 to:

- Allow the $\overline{\text{INT}}$ pin enough time to be pulled back high by the external pull-up resistor and allow the next assertion to be detectable by an edge-triggered microcontroller.
- Minimize the chance of glitching on the $\overline{\text{INT}}$ pin if back-to-back events occur.

When there is a pending interrupt event and the interrupt event is not masked, $t_{\text{INT_IDLE}}$ is applied after the READ command is issued to the INT_STAT register. If another event occurs during the interrupt idle time the INT_STAT register content is updated instantly but the $\overline{\text{INT}}$ pin is not asserted low until $t_{\text{INT_IDLE}}$ has elapsed. If another READ command is issued to the INT_STAT register during $t_{\text{INT_IDLE}}$, the INT_STAT register content is cleared immediately, but the $\overline{\text{INT}}$ pin is not re-asserted back low after $t_{\text{INT_IDLE}}$ has elapsed. An example of the interrupt idle time is given below to illustrate the $\overline{\text{INT}}$ pin behavior under the static $\overline{\text{INT}}$ assertion schemes:

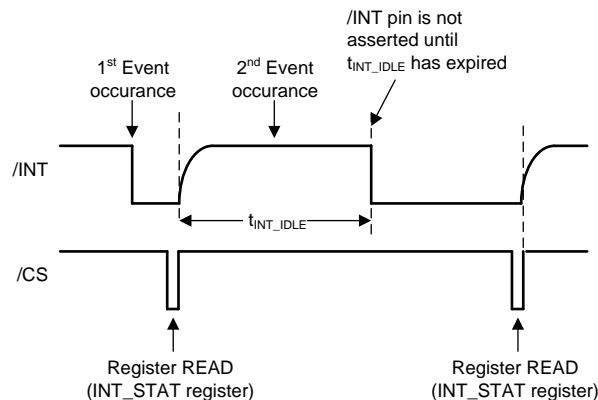

Figure 14. $\overline{\text{INT}}$ Assertion Scheme With $t_{\text{INT_IDLE}}$

8.3.9.3 Microcontroller Wake-Up

Using a few external components, the $\overline{\text{INT}}$ pin can be used for wake-up purpose to activate a voltage regulator via its inhibit inputs. An implementation example is shown in Figure 15. This implementation is especially useful for waking up a microcontroller in sleep mode to allow significant system-level power savings.

Before the wake-up event, the $\overline{\text{INT}}$ pin is in high impedance state on the TIC10024-Q1. The microcontroller can be kept in sleep state with all its GPIOs in logic low. Hence, Q2 remains off with its base in logic low state and the base of Q1 is weakly pulled-high to the V_S level. This causes Q1 to remain off, and the LDO_EN signal is pulled-down to logic low to disable the regulator's output. V_{DD} is therefore unavailable to both the TIC10024-Q1 device and the microcontroller and SPI communication is not supported. Switch status monitoring, however, is still active in the TIC10024-Q1.

When an event, such as switch status change, temperature warning, or overvoltage, occurs, the $\overline{\text{INT}}$ pin is asserted low by TIC10024-Q1, causing Q1 to turn on to activate the voltage regulator. The microcontroller is then reactivated, and the communication between the microcontroller and the TIC10024-Q1 is reestablished. The microcontroller can then access stored event information using SPI communication. Note since the $\overline{\text{INT}}$ pin is deasserted after the INT_STAT register is read, the microcontroller is required to keep the regulator on by driving the $\mu\text{C_LDO_EN}$ signal high. This allows V_{DD} to stay high to provide power to the microcontroller and support SPI communications.

The wake-up implementation is applicable only when the device is configured to use the static $\overline{\text{INT}}$ assertion scheme.

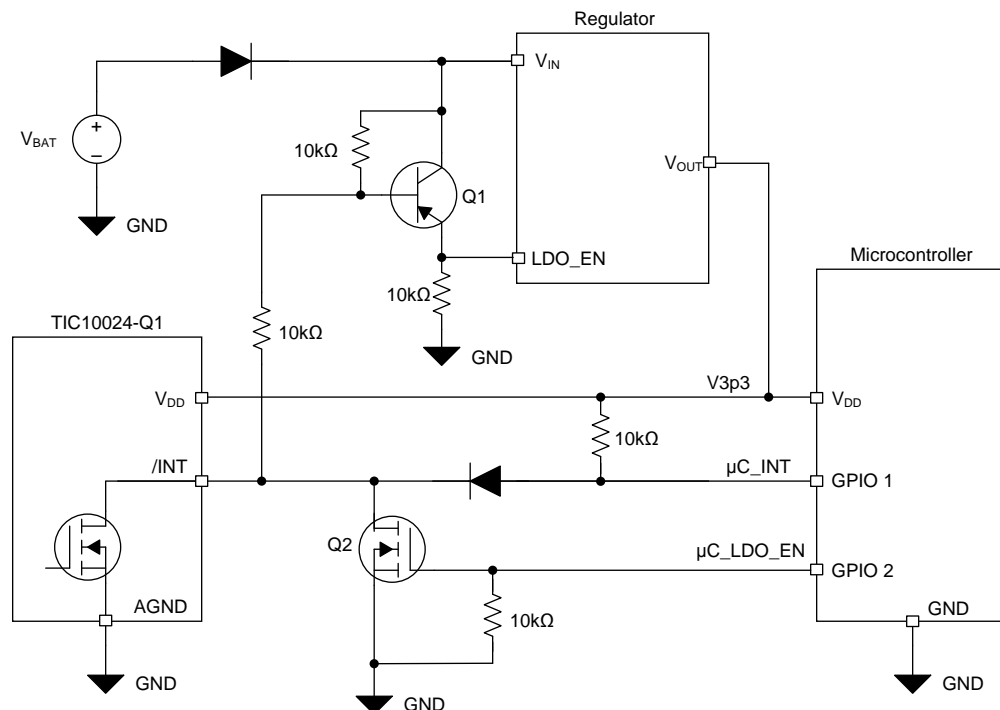

Figure 15. $\overline{\text{INT}}$ Connection to Support Microcontroller Wake-Up

8.3.9.4 Interrupt Enable / Disable And Interrupt Generation Conditions

Each switch input can be programmed to enable or disable interrupt generation upon status change by configuring registers [INT_EN_COMP1](#) to [INT_EN_COMP2](#).

The abovementioned registers can also be used to control interrupt generation condition based on the following settings:

1. **Rising edge:** an interrupt is generated if the current input measurement is above the corresponding threshold and the previous measurement was below.
2. **Falling edge:** an interrupt is generated if the current input measurement is below the corresponding threshold and the previous measurement was above.
3. **Both edges:** changes of the input voltage in either direction results in an interrupt generation.

Note interrupt generation from switch status change is disabled for all inputs by default upon device reset.

8.3.9.5 Detection Filter

When monitoring the switch input status a detection filter can be configured by setting the DET_FILTER bits in the CONFIG register to generate Switch Status Change (SSC) interrupt only if the same input status (w.r.t the threshold) is sampled consecutively. This detection filter can be useful to debounce inputs during a switch toggle events. Four different filtering schemes are available:

1. Generate an SSC interrupt if the voltage level at an input crossed its threshold
2. Generate an SSC interrupt if the voltage level at an input crossed its threshold and the status is stable (w.r.t. the threshold) for at least 2 consecutive polling cycles
3. Generate an SSC interrupt if the voltage level at an input crossed its threshold and the status is stable (w.r.t. the threshold) for at least 3 consecutive polling cycles
4. Generate an SSC interrupt if the voltage level at an input crossed its threshold and the status is stable (w.r.t. the threshold) for at least 4 consecutive polling cycles

The default value of switch status is stored internally after the 1st detection cycle, even if detection filter (by configure the DET_FILTER in the CONFIG register) is used. An example is illustrated below with the assumption that DET_FILTER in register CONFIG is set to 11 (SSC interrupt is generated if the input crosses the threshold and the status is stable w.r.t. the threshold for at least 4 consecutive detection cycles). Assume switch status change is detected in the 3rd detection cycle and stays the same for the next 3 cycles.

DETECTION CYCLE	1	2	3	4	5	6
Event	<ul style="list-style-type: none"> • Default Switch status stored • $\overline{\text{INT}}$ asserted • SSC flagged 	—	Switch status change detected	—	—	<ul style="list-style-type: none"> • $\overline{\text{INT}}$ asserted • SSC flagged

The detection filter counter is reset to 0 when the TRIGGER bit in the CONFIG register is de-asserted to logic 0. Upon device reset, the default setting for the detection filter is set to generating an SSC interrupt at every threshold crossing.

8.3.10 Temperature Monitor

With multiple switch inputs are closed and high wetting current setting is enabled, considerable power could be dissipated by the device and raise the device temperature. TIC10024-Q1 has integrated temperature monitoring and protection circuitry to put the device in low power mode to prevent damage due to overheating. Two types of temperature protection mechanisms are integrated in the device: Temperature Warning (TW) and Temperature Shutdown (TSD). The triggering temperatures and hysteresis are specified in Table 2 below:

Table 2. Temperature Monitoring Characteristics of TIC10024-Q1

PARAMETER	MIN	TYP	MAX	UNIT
Temperature warning trigger temperature (T_{TW})	130	140	155	°C
Temperature shutdown trigger temperature (T_{TSD})	150	160	175	°C
Temperature hysteresis (T_{HYS}) for T_{TW} and T_{TSD}		15		°C

8.3.10.1 Temperature Warning (TW)

When the device temperature goes above the temperature warning trigger temperature (T_{TW}), the TIC10024-Q1 performs the following operations:

1. Generate an interrupt by asserting the $\overline{\text{INT}}$ pin low and flag the TW bit in INT_STAT register to logic 1. The TEMP bit in the SPI flag is also flagged to logic 1 for all SPI transactions.
2. The TW_STAT bit of the IN_STAT_MISC register is flagged to logic 1.
3. If the TW_CUR_DIS_CSO or TW_CUR_DIS_CSO bit in CONFIG register is set to logic 0 (default), the wetting current is adjusted down to 2 mA for 10 mA or 15 mA settings. The wetting current stays at its pre-configured value if 0 mA, 1 mA, 2 mA, or 5 mA setting is used.
4. Maintain the low wetting current as long as the device junction temperature stays above $T_{TW} - T_{HYS}$.

The $\overline{\text{INT}}$ pin is released and the INT_STAT register content is cleared on the rising edge of $\overline{\text{CS}}$ provided the INT_STAT register has been read during $\overline{\text{CS}}$ low. The TIC10024-Q1 continues to monitor the temperature, but does not issue further interrupts if the temperature continues to stay above $T_{\text{TW}} - T_{\text{HYS}}$. The status bit TW_STAT in register IN_STAT_MISC continues to stay at logic 1 as long as the temperature warning condition exists.

If desired, the reduction of wetting current down to 2mA setting (from 10 mA or 15 mA) can be disabled by setting the TW_CUR_DIS_CSO or TW_CUR_DIS_CSI bit in the [CONFIG](#) register to 1. The interrupt is still generated ($\overline{\text{INT}}$ asserted low and INT_STAT interrupt register is updated) when the temperature warning event occurs but the wetting current is not reduced. This setting applies to both the polling and continuous mode operation. Note if the feature is enabled, switch detection result might be impacted upon T_{TW} event if the wetting current is reduced to 2mA from 10mA or 15mA.

When the temperature drops below $T_{\text{TW}} - T_{\text{HYS}}$, the $\overline{\text{INT}}$ pin is asserted low (if released previously) to notify the microcontroller that the temperature warning condition no longer exists. The TW bit of the interrupt register INT_STAT is flagged logic 1. The TW_STAT bit in the IN_STAT_MISC register is de-asserted back to logic 0. The device resumes operation using the current programmed settings (regardless of the $\overline{\text{INT}}$ and $\overline{\text{CS}}$ status).

8.3.10.2 Temperature Shutdown (TSD)

After the device enters TW condition, if the junction temperature continues to rise and goes above the temperature shutdown threshold (T_{TSD}), the TIC10024-Q1 enters the Temperature Shutdown (TSD) condition and performs the following operations:

1. Opens all the switches connected to the current sources/sinks to prevent any further heating due to excessive current flow.
2. Generate an interrupt by asserting the $\overline{\text{INT}}$ pin (if not already asserted) low and flag the TSD bit in the INT_STAT register to logic 1. The TEMP bit in the SPI flag is also flagged to logic 1 for all SPI transactions.
3. The TSD_STAT bit of the IN_STAT_MISC register is flagged to logic 1. The TW_STAT bit also stays at logic 1.
4. SPI communication stays on and all register settings stay intact without resetting. Previous switch status, if needed, can be retrieved without any interruption.
5. Maintain the setting as long as the junction temperature stays above $T_{\text{TSD}} - T_{\text{HYS}}$.

The $\overline{\text{INT}}$ pin is released and the INT_STAT register content is cleared on the rising edge of $\overline{\text{CS}}$ provided the INT_STAT register has been read during $\overline{\text{CS}}$ low. The TIC10024-Q1 continues to monitor the temperature, but does not issue further interrupts if the temperature continues to stay above $T_{\text{TSD}} - T_{\text{HYS}}$. The status bit TSD_STAT in register IN_STAT_MISC continues to stay at logic 1 as long as the temperature shutdown condition exists.

When the temperature drops below $T_{\text{TSD}} - T_{\text{HYS}}$, the $\overline{\text{INT}}$ pin is asserted low (if released previously) to notify the microcontroller that the temperature shutdown condition no longer exists. The TSD bit of the interrupt register INT_STAT is flagged logic 1. In the IN_STAT_MISC register, the TSD_STAT bit is de-asserted back to logic 0, while the TW_STAT bit stays at logic 1. The device resumes operation using the wetting current setting described in section [Temperature Warning](#) if the temperature stays above $T_{\text{TW}} - T_{\text{HYS}}$. Note the polling restarts from the first enabled channel and the SSC interrupt is generated at the end of the first polling cycle. The detected switch status from the first polling cycle becomes the default switch status for subsequent polling.

8.3.11 Parity Check And Parity Generation

The TIC10024-Q1 uses parity bit check to ensure error-free data transmission from/to the SPI master.

The device uses odd parity, for which the parity bit is set so that the total number of ones in the transmitted data on SO (including the parity bit) is an odd number (i.e. $\text{Bit0} \oplus \text{Bit1} \oplus \dots \oplus \text{Bit30} \oplus \text{Bit31} \oplus \text{Parity} = 1$).

The device also uses odd parity check after receiving data on SI from the SPI master. If the total number of ones in the received data (including the parity bit) is an even number the received data is discarded. The $\overline{\text{INT}}$ will be asserted low and the PRTY_FAIL bit in the interrupt register (INT_STAT) is flagged to logic 1 to notify the host that transmission error occurred. The PRTY_FAIL flag is also asserted during SPI communications.

8.3.12 Cyclic Redundancy Check (CRC)

The TIC10024-Q1 includes a CRC module to support redundancy checks on the configuration registers to ensure the integrity of data. The CRC calculation is based on the ITU-T X.25 implementation, and the CRC polynomial (0x1021) used is popularly known as CRC-CCITT-16 since it was initially proposed by the ITU-T (formerly CCITT) committee. The CRC calculation rule is defined in [Table 3](#):

Table 3. CRC Calculation Rule

CRC RULE	VALUE
CRC result width	16 bits
Polynomial	$x^{16} + x^{12} + x^5 + 1$ (1021h)
Initial (seed) value	FFFFh
Input data reflected	No
Result data reflected	No
XOR value	0000h

The CRC calculation is done on all the configuration registers starting from register [CONFIG](#) and ending at the last reserved register at address 32h. The device substitutes a “zero” for each reserved configuration register bit during the CRC calculation. The CRC calculation can be triggered by asserting the CRC_T bit in the CONFIG register. Once completed, the CRC_CALC interrupt bit in the INT_STAT register is asserted and an interrupt is issued. The 16-bit CRC calculation result is stored in the register CRC. This interrupt can be disabled by de-asserting the CRC_CALC_EN bit in the INT_EN_CFG0 register. It is important to avoid writing data to the configuration registers when the device is undergoing CRC calculations to prevent false calculation results.

[Figure 16](#) shows the block diagram of the CRC module. The module consists of 16 shift-registers and 3 exclusive-OR gates. The registers start with 1111-1111-1111-1111 (or FFFFh) and the module performs an XOR function and shifts its content until the last bit of the register string is used. The final register's content after the last data bit is the calculated CRC value of the data set and the content is stored in the CRC register.

Note the CRC_T bit self-clears after the CRC calculation is completed. Logic 1 is used for CRC_T bit during CRC calculation.

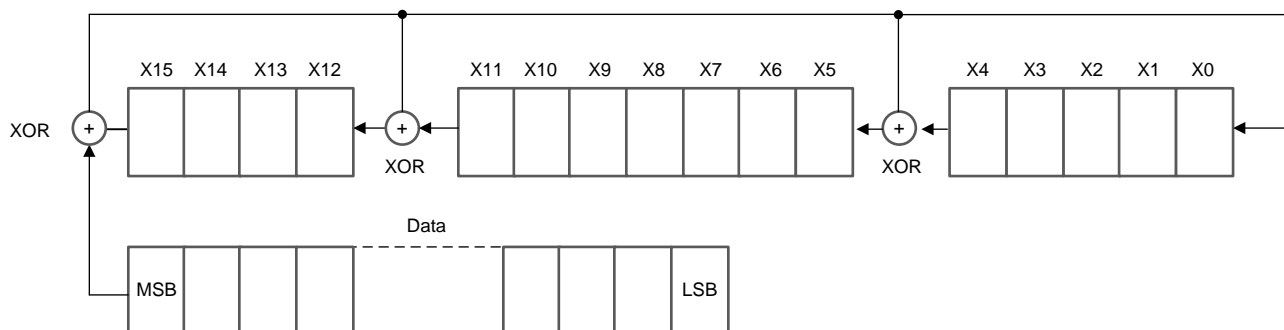

Figure 16. CCITT-16 CRC Module Block Diagram

8.4 Device Functional Modes

The TIC10024-Q1 has 2 modes of operation: continuous mode and polling mode. The following sections describe the two operation modes in details as well as some of the advanced features that could be activated during normal operations.

8.4.1 Continuous Mode

In continuous mode, wetting current is continuously applied to each enabled input channel, and the status of each channel is sampled sequentially (starting from the IN0 to IN23). The TIC10024-Q1 monitors enabled inputs and issues an interrupt (if enabled) if a switch status change event is detected. The wetting current setting for each input can be individually adjusted by configuring the *WC_CFG0* and *WC_CFG1* to the 0mA, 1mA, 2mA, 5mA, 10mA, or 15mA setting.

Figure 17 below illustrates an example of the timing diagram of the detection sequence in continuous mode. After the TRIGGER bit in register *CONFIG* is set to logic 1, it takes $t_{STARTUP}$ to activate the wetting current for all enabled inputs. The wetting currents stay on continuously, while each input is routed to the comparator for sampling in a sequential fashion. After detection is done for an input, the switch status (below or above detection threshold) is stored in the register (*IN_STAT_COMP*) to be used as the default state for subsequent detection cycles. After the end of the first polling cycle, the \overline{INT} pin is asserted low to notify the microcontroller that the default switch status is ready to be read. The SSC bit in INT_STAT register and the SPI status flag SSC are also asserted to logic 1. The polling cycle time (t_{POLL}) determines how frequently each input is sampled and can be configured in the register *CONFIG*.

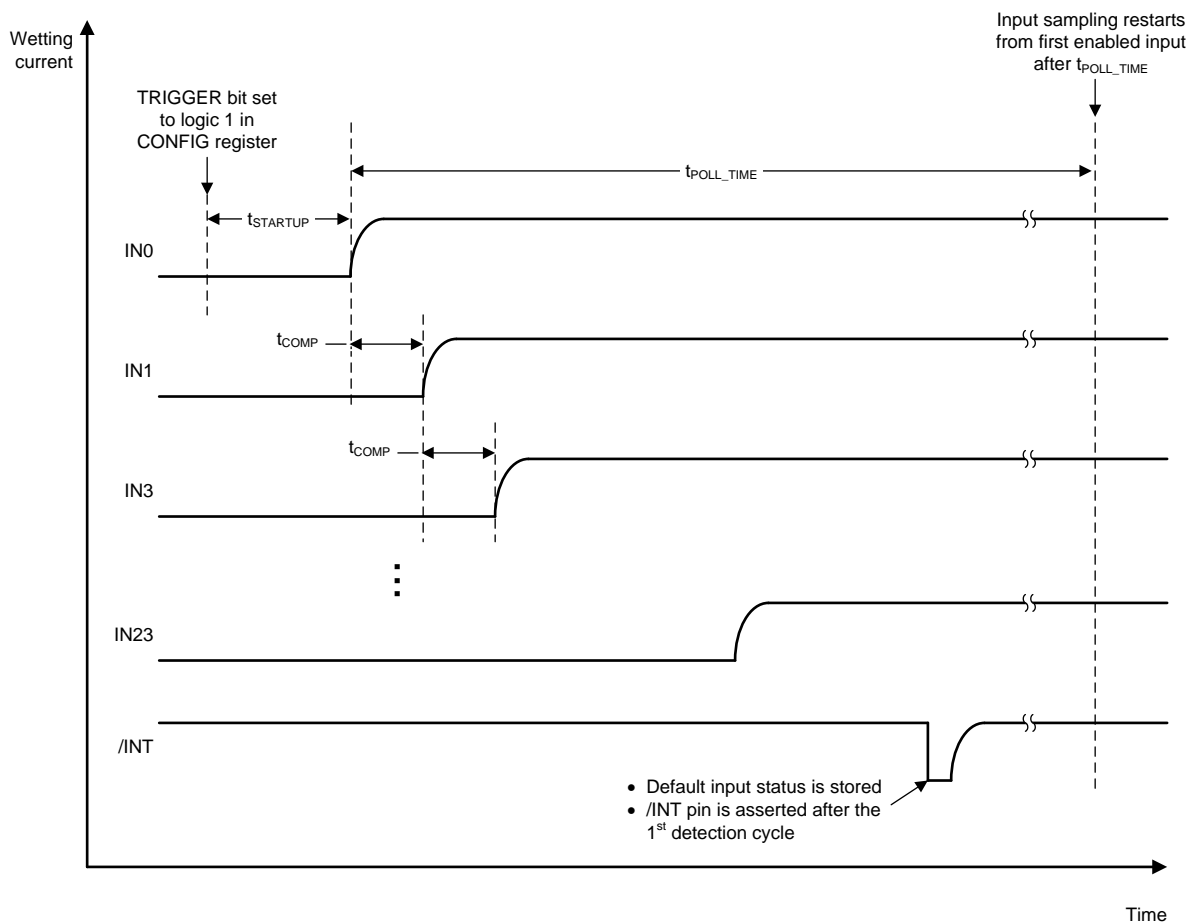

Figure 17. An Example Of The Detection Sequence In Continuous Mode

The *INT_STAT* register is cleared and \overline{INT} pin de-asserted if a SPI READ command is issued to the register. Note the interrupt is always generated after the 1st detection cycle (after the TRIGGER bit in register *CONFIG* is set to logic 1). In subsequent detection cycles, the interrupt is generated only if switch status change is detected.

Device Functional Modes (continued)

No wetting currents are applied to 0mA- configured inputs, although some biasing current (as specified by $I_{IN_LEAK_0mA}$) may still flow in and out of the input. Threshold crossing monitoring is still performed for the input using the defined threshold(s). The 0mA setting is useful to utilize the integrated comparator to measure applied voltage on a specific input without being affected by the device wetting current.

8.4.2 Polling Mode

The polling mode can be activated to reduce current drawn in ignition-off condition to conserve battery charge. Unlike the continuous mode, the current sources/sinks do not stay on continuously in the polling mode. Instead, they are turned on/off sequentially from IN0 to IN23 and cycled through each individual input channel. The microcontroller can be put to sleep to reduce overall system power. If a switch status change (SSC) is detected by the TIC10024-Q1, the \overline{INT} pin (if enabled for the input channel) is asserted low (and the SSC bit in INT_STAT register and the SPI status flag SSC are also asserted to logic 1). The \overline{INT} pin assertion can be used to wake up the system regulator which, in turn, wakes up the microcontroller as described in section [Microcontroller Wake-Up](#). The microcontroller can then use SPI communication to read the switch status information.

The polling is activated when the TRIGGER bit in the [CONFIG](#) register is set to logic 1.

In polling mode, wetting current is applied to each input for a pre-programmed polling active time between 64 μ s and 2048 μ s, set by the POLL_ACT_TIME bits in the [CONFIG](#) register. At the end of the wetting current application, the input voltage is sampled by the comparator. Each input is cycled through in sequential order from IN0 to IN23. Sampling is repeated at a frequency from 2 ms to 4096 ms, set by the POLL_TIME bits in the [CONFIG](#) register. Wetting currents are applied to closed switches only during the polling active time; hence the overall system current consumption can be greatly reduced.

Similar to continuous mode, after the first polling cycle, the switch status of each input (below or above detection threshold) is stored in the register ([IN_STAT_COMP](#)) to be used as the default state for subsequent polling cycles. The \overline{INT} pin is asserted low to notify the microcontroller that the default switch status is ready to be read. The SSC bit in INT_STAT register and the SPI status flag SSC are also asserted to logic 1. The [INT_STAT](#) register is cleared and \overline{INT} pin de-asserted if a SPI READ command is issued to the register. Note the interrupt is always generated after the 1st polling cycle (after the TRIGGER bit in register [CONFIG](#) is set to logic 1). In subsequent polling cycles the interrupt is generated only if switch status change is detected.

An example of the timing diagram of the polling mode operation is shown in [Figure 18](#).

Device Functional Modes (continued)

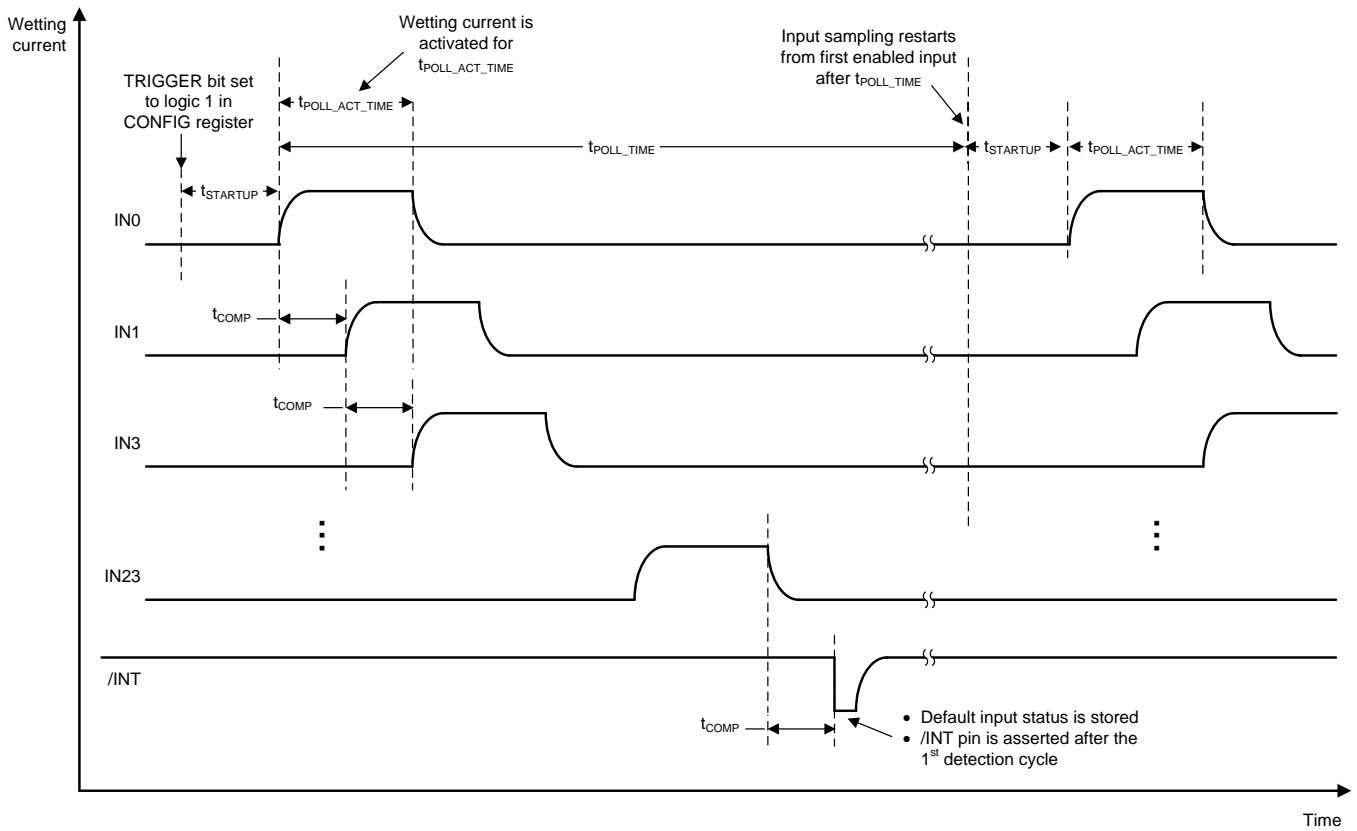

Figure 18. An Example Of The Polling Sequence In Standard Polling Mode

Device Functional Modes (continued)

If the switch position changes between two active polling times, no interrupt will be generated and the status register (*IN_STAT_COMP*) will not reflect such a change. An example is shown in [Figure 19](#).

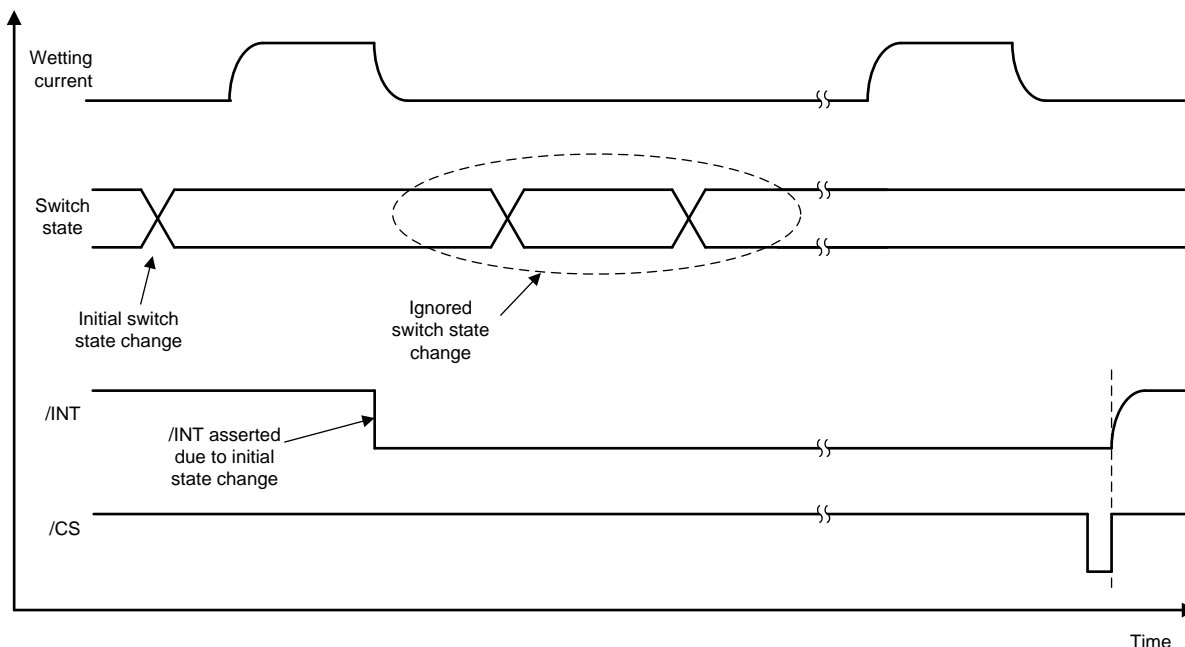

Figure 19. Example For Ignored Switch Position Change Between 2 Wetting Current Cycles

8.4.3 Additional Features

There are additional features that can be enabled during continuous and polling mode to increase robustness of device operation or provide more system information. These features are described in detail in the following sections.

8.4.3.1 Clean Current Polling (CCP)

In real automotive system, lower wetting current is generally desired to reduce the system's overall power consumption. However, certain system design requires 10 mA or higher cleaning current to clear oxide build-up on the mechanical switch contact surface when the current is applied to closed switches. A special type of polling, called the Clean Current Polling (CCP), can be used for this application.

If CCP is enabled each polling cycle consists of two wetting current activation steps. The first step uses the wetting current setting configured in the *WC_CFG0* and *WC_CFG1* registers as in the continuous mode or polling mode. The second step (cleaning cycle) is activated simultaneously for all CCP enabled inputs at a time t_{CCP_TRAN} after the normal polling step of the last enabled input. Interrupt generation and *INT* pin assertion is not impacted by the clean current pulses.

The wetting current and its active time for the cleaning cycle can be configured in the *CCP_CFG0* register. The cleaning cycle can be disabled, if desired, for each individual input by programming the *CCP_CFG1* register. CCP is available for both continuous mode and polling mode. To use the CCP feature, at least one input has to be enabled.

Device Functional Modes (continued)

Figure 20 illustrates the operation of the CCP when the device is configured to the polling mode.

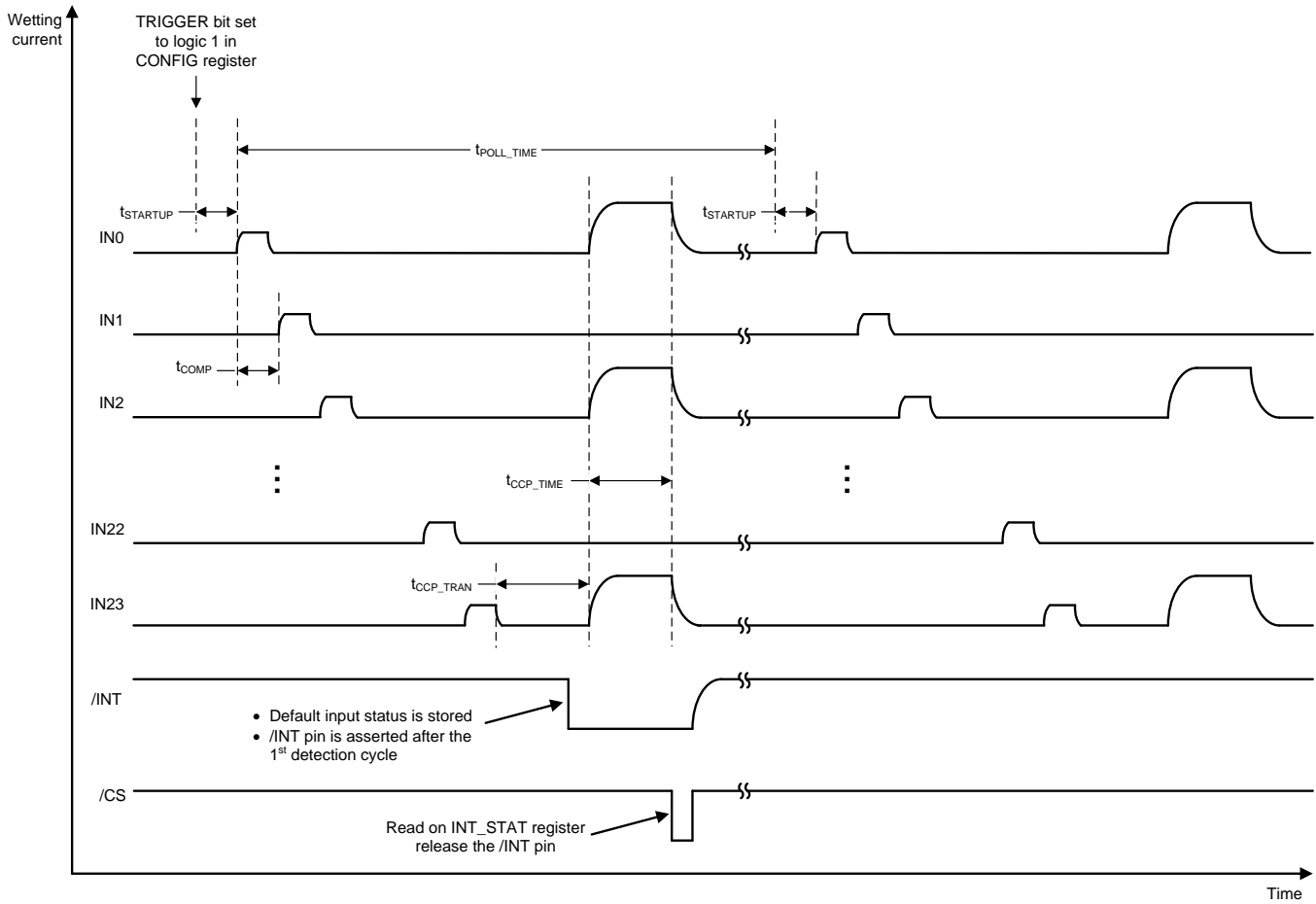

Figure 20. Polling With CCP Enabled

Device Functional Modes (continued)

Figure 21 illustrates the operation of the CCP when the device is configured to the continuous mode:

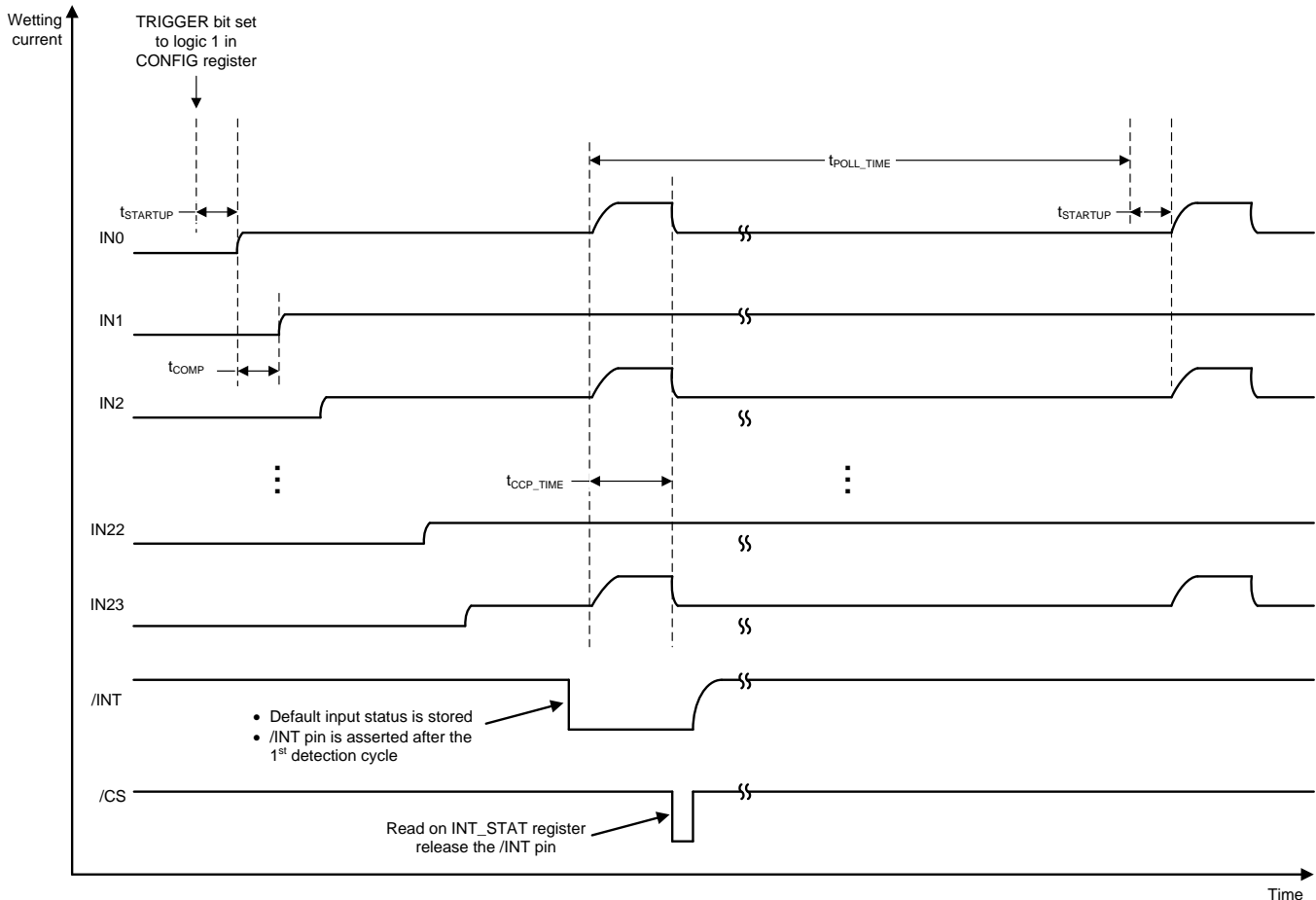

Figure 21. Continue Mode With CCP Enabled

8.4.3.2 Wetting Current Auto-Scaling

The 10 mA and 15 mA wetting current settings are useful to clean oxide build-up on the mechanical switch contact surface when the switch changes state from open to close. After the switch is closed, it is undesirable to keep the wetting current level at high level if only digital switches are monitored since it results in high current consumption and could potentially heat up the device quickly if multiple inputs are monitored. The wetting current auto-scaling feature helps mitigate this issue.

When enabled (AUTO_SCALE_DIS_CSO or AUTO_SCALE_DIS_CSI bit = logic 0 in the [WC_CFG1](#) register), wetting current is reduced to 2 mA from 10 mA or 15 mA setting after switch closure is detected. The threshold used to determine a switch closure is the threshold configured in the [THRES_COMP](#) register.

The current reduction takes place N cycles after switch closure is detected on an input, where N depends on the setting of the DET_FILTER bits in the [CONFIG](#) register:

- DET_FILTER= 00: wetting current is reduced immediately in the next detection cycle after a closed switch is detected.
- DET_FILTER= 01: wetting current is reduced when a closed switch is detected and the switch status is stable for at least 2 consecutive detection cycles.
- DET_FILTER= 10: wetting current is reduced when a closed switch is detected and the switch status is stable for at least 3 consecutive detection cycles.
- DET_FILTER= 11: wetting current is reduced when a closed switch is detected and the switch status is stable for at least 4 consecutive detection cycles.

Device Functional Modes (continued)

The wetting current is adjusted back to the original setting of 10 mA or 15 mA at a time of N cycles after an open switch is detected, where N again depends on the DET_FILTER bit setting in the [CONFIG](#) register. [Figure 22](#) depicts the behavior of the wetting current auto-scaling feature.

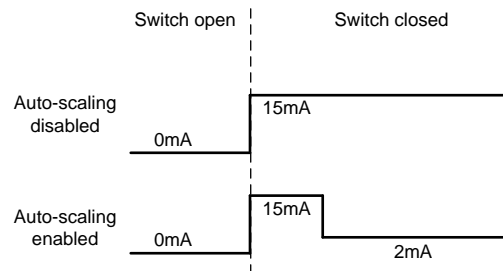

Figure 22. Wetting Current Auto-scaling Behavior

The wetting current auto-scaling only applies to 10 mA and 15 mA settings and is only available in continuous mode. If AUTO_SCALE_DIS_CSO or AUTO_SCALE_DIS_CSI bit is set to logic 1 in the [WC_CFG1](#) registers, the wetting current stays at its original setting when a closed switch is detected. Power dissipation needs to be closely monitored when wetting current auto-scaling is disabled for multiple inputs as the device could heat up quickly when high wetting current settings are used. If the auto-scaling feature is disabled in continuous mode, the total power dissipation can be approximated using [Equation 1](#).

$$P_{TOTAL} = V_S \times (I_{S_CONT} + I_{WETT(TOTAL)}) \quad (1)$$

where $I_{WETT(TOTAL)}$ is the sum of all wetting currents from all input channels. Increase in device junction temperature can be calculated based on $P \times R_{\theta JA}$. The junction temperature must be below T_{TSD} for proper device operation. An interrupt will be issued when the junction temperature exceeds T_{TW} or T_{TSD} . For detailed description of the temperature monitoring, please refer to sections [Temperature Warning \(TW\)](#) and [Temperature Shutdown \(TSD\)](#).

9 Programming

The SPI interface communication consists of the 4 pins: \overline{CS} , SCLK, SI, and SO. The interface can work with SCLK frequency up to 4 MHz.

9.1 SPI Communication Interface Buses

9.1.1 Chip Select (\overline{CS})

The system microcontroller selects the TIC10024-Q1 to receive communication using the \overline{CS} pin. With the \overline{CS} pin in a logic LOW state, command words may be sent to the TIC10024-Q1 via the serial input (SI) pin, and the device information can be retrieved by the microcontroller via the serial output (SO) pin. The falling edge of the \overline{CS} enables the SO output and latches the content of the interrupt register INT_STAT. The microcontroller may issue a READ command to retrieve information stored in the registers. Rising edge on the \overline{CS} pin initiates the following operations:

1. Disable the output driver and makes SO high-impedance.
2. \overline{INT} pin is reset to logic HIGH if a READ command to the INT_STAT register was issued during $\overline{CS} = \text{LOW}$.

To avoid corrupted data, it is essential the HIGH-to-LOW and LOW-to-HIGH transitions of the \overline{CS} signal occur only when SCLK is in a logic LOW state. A clean \overline{CS} signal is needed to ensure no incomplete SPI words are sent to the device. The \overline{CS} pin should be externally pulled up to VDD by a 10 k Ω resistor.

9.1.2 System Clock (SCLK)

The system clock (SCLK) input is used to clock the internal shift register of the TIC10024-Q1. The SI data is latched into the input shift register on the falling edge of the SCLK signal. The SO pin shifts the device stored information out on the rising edge of SCLK. The SO data is available for the microcontroller to read on the falling edge of SCLK.

False clocking of the shift register must be avoided to ensure validity of data and it is essential the SCLK pin be in a logic LOW state whenever \overline{CS} makes any transition. Therefore, it is recommended that the SCLK pin gets pulled to a logic LOW state as long as the device is not accessed and \overline{CS} is in a logic HIGH state. When the \overline{CS} is in a logic HIGH state, any signal on the SCLK and SI pins will be ignored and the SO pin remains as a high impedance output. Refer to [Figure 23](#) and [Figure 24](#) for examples of typical SPI read and write sequence.

9.1.3 Slave In (SI)

The SI pin is used for serial instruction data input. SI information is latched into the input register on the falling edge of the SCLK. To program a complete word, 32 bits of information must be entered into the device. The SPI logic counts the number of bits clocked into the IC and enables data latching only if exactly 32 bits have been clocked in. In case the word length exceeds or does not meet the required length, the SPI_FAIL bit of the INT_STAT register is asserted to logic 1 and the \overline{INT} pin will be asserted low. The data received is considered invalid. Note the SPI_FAIL bit is not flagged if SCLK is not present.

9.1.4 Slave Out (SO)

The SO pin is the output from the internal shift register. The SO pin remains high-impedance until the \overline{CS} pin transitions to a logic LOW state. The negative transition of \overline{CS} enables the SO output driver and drives the SO output to the HIGH state (by default). The first positive transition of SCLK makes the status data bit 31 available on the SO pin. Each successive positive clock makes the next status data bit available for the microcontroller to read on the falling edge of SCLK. The SI/SO shifting of the data follows a first-in, first-out scheme, with both input and output words transferring the most significant bit (MSB) first.

9.2 SPI Sequence

Figure 23 and Figure 24 depict the SPI communication sequence during read and write operations for the TIC10024-Q1.

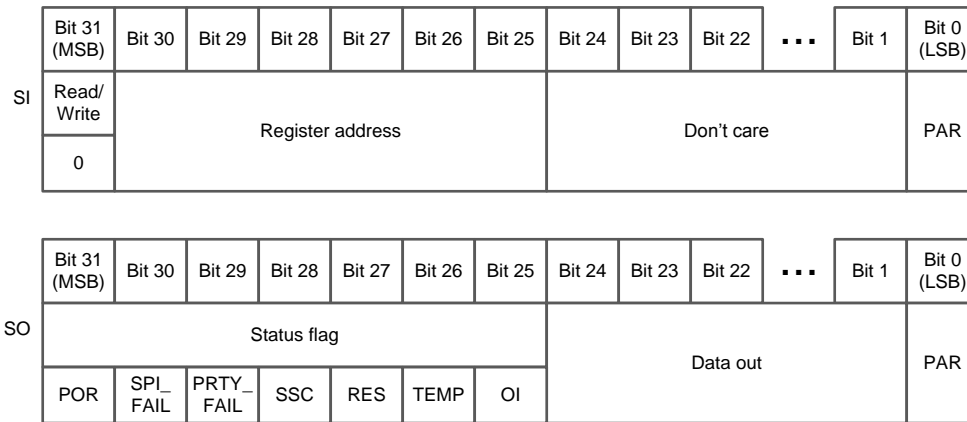

Figure 23. TIC10024-Q1 Read SPI Sequence

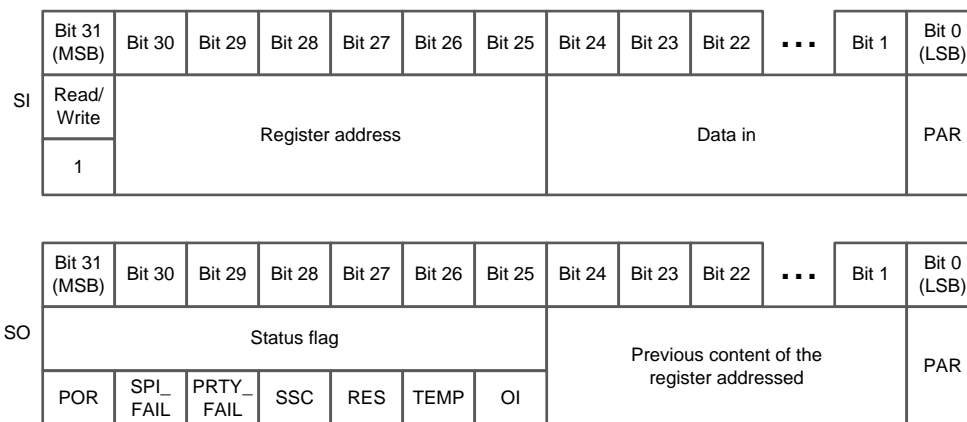

Figure 24. TIC10024-Q1 Write SPI Sequence

9.2.1 Read Operation

The Read/Write bit (bit 31) of the SI bus needs to be set to logic 0 for a READ operation. The 6-bits address of the register to be accessed follows next on the SI bus. The content from bit 24 to bit 1 does not represent a valid command for a read operation and will be ignored. The LSB (bit 0) is the parity bit used to detect communication errors.

On the SO bus, the status flags will be outputted from the TIC10024-Q1, followed by the data content in the register that was requested. The LSB is the parity bit used to detect communication errors.

Note there are several test mode registers used in the TIC10024-Q1 in addition to the normal functional registers, and a READ command to these test registers returns the register content. If a READ command is issued to an invalid register address, the TIC10024-Q1 returns all 0's.

9.2.2 Write Operation

The Read/Write bit (bit 31) on the SI bus needs to be set to 1 for a write operation. The 6-bits address of the register to be accessed follows next on the SI bus. Note the register needs to be a writable configuration register, or otherwise the command will be ignored. The content from bit 24 to bit 1 represents the data to be written to the register. The LSB (bit 0) is the parity bit used to detect communication errors.

SPI Sequence (continued)

On the SO bus, the status flags will be output from the TIC10024-Q1, followed by the previous data content of the written register. The previous content of the register is latched after the full register address is decoded in the SI command (after bit 25 is transmitted). The new data will replace the previous data content at the end of the SPI transaction if the SI write is a valid command (valid register address and no SPI/parity error). If the write command is invalid, the new data will be ignored and the register content will remain unchanged. The LSB is the parity bit used to detect communication errors.

Note there are several test mode registers used in the TIC10024-Q1 in addition to the normal functional registers. A WRITE command to these test registers has no effect on the register content, even though the register content is returned on the SO output. If a WRITE command is issued to an invalid register address, the SO output returns all 0's.

9.2.3 Status Flag

The status flags are output from SO during every READ or WRITE SPI transaction to indicate system conditions. These bits do not belong to an actual register, but their content is mirrored from the interrupt register INT_STAT. A READ command executed on the INT_STAT would clear both the bits inside the register and the status flag. The following table describes the information that can be obtained from each SPI status flag:

Table 4. TIC10024-Q1 SPI Status Flag Description

SYMBOL	NAME	DESCRIPTION
POR	Power-on Reset	This flag mirrors the POR bit in the interrupt register INT_STAT, and it indicates, if set to 1, that a reset event has occurred. This bit is asserted after a successful power-on-reset, hardware reset, or software reset. Refer to section Device Reset for more details.
SPI_FAIL	SPI Error	This flag mirrors the SPI_FAIL bit in the interrupt register INT_STAT and it indicates, if set to 1, that the last SPI Slave In (SI) transaction is invalid. To program a complete word, 32 bits of information must be entered into the device. The SPI logic counts the number of bits clocked into the IC and enables data latching only if exactly 32 bits have been clocked in. In case the word length exceeds or does not meet the required size, the SPI_FAIL bit, which mirrors its value to this SPI_FAIL status flag, of the interrupt register INT_STAT will be set to 1 and the INT pin will be asserted low. The data received will be considered invalid. Once the INT_STAT register is read, its content will be cleared on the rising edge of CS. The SPI_FAIL status flag, which mirrors the SPI_FAIL bit in the INT_STAT register, will also be de-asserted. Note the SPI_FAIL bit is not flagged if SCLK is not present.
PRTY_FAIL	Parity Fail	This flag mirrors the PRTY_FAIL bit in the interrupt register INT_STAT and it indicates, if set to 1, that the last SPI Slave In (SI) transaction has a parity error. The device uses odd parity. If the total number of ones in the received data (including the parity bit) is an even number, the received data is discarded. The INT will be asserted low and the PRTY_FAIL bit in the interrupt register (INT_STAT) is flagged to logic 1, and the PRTY_FAIL status flag, which mirrors the PRTY_FAIL bit in the INT_STAT register, is also set to 1. Once the INT_STAT register is read, its content will be cleared on the rising edge of CS. The PRTY_FAIL status flag, which mirrors the PRTY_FAIL bit in the INT_STAT register, will also be de-asserted.
SSC	Switch State Change	This flag mirrors the SSC bit in the interrupt register INT_STAT and it indicates, if set to 1, that one or more switch inputs crossed a threshold. To determine the origin of the state change, the microcontroller can read the content of the register IN_STAT_COMP. Once the interrupt register (INT_STAT) is read, its content will be cleared on the rising edge of CS. The SSC status flag, which mirrors the SSC bit in the INT_STAT register, will also be de-asserted.
RES	Reserved	This flag is reserved and is always at logic 0.
TEMP	Temperature Event	This flag is set to 1 if either Temperature Warning (TW) or Temperature Shutdown (TSD) bit in the interrupt register INT_STAT is flagged to 1. It indicates a TW event or a TSD event has occurred. It is also flagged to 1 if a TW event or a TSD event is cleared. The interrupt register INT_STAT should be read to determine which event occurred. The SPI master can also read the IN_STAT_MISC register to get information on the temperature status of the device. Once the interrupt register (INT_STAT) is read, its content will be cleared on the rising edge of CS, and the TEMP status flag will also be de-asserted.
OI	Other Interrupt	Other interrupt include interrupts such as OV, UV, CRC_CALC and CHK_FAIL. This flag will be asserted 1 when any of the abovementioned bits is flagged in the interrupt register INT_STAT. The interrupt register INT_STAT should be read to determine which event(s) occurred. The SPI master can also read the IN_STAT_MISC register to get information on the latest status of the device. Once the INT_STAT register is read, its content will be cleared on the rising edge of CS, and the OI status flag will also be de-asserted.

9.3 Programming Guidelines

When configuring the TIC10024-Q1, it is critical to follow the programming guideline summarized below (see [Table 5](#)) to ensure proper behavior of the device:

Table 5. TIC10024-Q1 Programming Guidelines

Category	Programming Requirement
Clean Current Polling (if CCP_INx = 1 in the CCP_CFG1 register)	At least one input has to be enabled: IN_EN_x = 1 in the IN_EN register
Wetting current auto-scaling (if WC_CFG1 [22:21] != 2b'11)	<ul style="list-style-type: none"> The wetting current auto-scaling feature is only activated in the continuous mode: POLL_EN = 0 ⁽¹⁾ The wetting current auto-scaling only applies to 10mA or 15mA wetting currents: WC_INx bits = 3'b100, 3'b101, 3'b110, or 3'b111 in the WC_CFG0 and WC_CFG1 registers. ⁽¹⁾
Continuous mode Polling mode	t_{POLL_TIME} and $t_{POLL_ACT_TIME}$ settings have to meet the below requirement: $t_{POLL_TIME} \geq 1.3 \times [t_{POLL_ACT_TIME} + n \times 24 \mu s + 10 \mu s]$ ⁽²⁾ <ul style="list-style-type: none"> n: the number of enabled channels configured in register IN_EN t_{POLL_TIME}: timing setting configured in CONFIG[4:1] $t_{POLL_ACT_TIME}$: timing setting configured in CONFIG[8:5]

(1) These are soft requirements to take advantage of the wetting current auto-scaling feature. The feature takes no effect otherwise.

(2) If CCP is enabled, add $t_{CCP_TRAN} + t_{CCP_TIME}$, where t_{CCP_TIME} is the timing setting configured in CCP_CFG0[6:4]

9.4 Register Maps

[Table 6](#) lists the memory-mapped registers for the TIC10024-Q1. All register offset addresses not listed in [Table 6](#) should be considered as reserved locations and the register contents should not be modified.

Table 6. TIC10024-Q1 Registers

OFFSET	TYPE	RESET	ACRONYM	REGISTER NAME	SECTION
1h	R	120h	DEVICE_ID	Device ID Register	Go
2h	RC	1h	INT_STAT	Interrupt Status Register	Go
3h	R	FFFFh	CRC	CRC Result Register	Go
4h	R	0h	IN_STAT_MISC	Miscellaneous Status Register	Go
5h	R	0h	IN_STAT_COMP	Comparator Status Register	Go
6h-19h	—	—	RESERVED	RESERVED	—
1Ah	R/W	0h	CONFIG	Device Global Configuration Register	Go
1Bh	R/W	0h	IN_EN	Input Enable Register	Go
1Ch	R/W	0h	CS_SELECT	Current Source/Sink Selection Register	Go
1Dh-1Eh	R/W	0h	WC_CFG0, WC_CFG1	Wetting Current Configuration Register	Go
1Fh-20h	R/W	0h	CCP_CFG0, CCP_CFG1	Clean Current Polling Register	Go
21h	R/W	0h	THRES_COMP	Comparator Threshold Control Register	Go
22h-23h	R/W	0h	INT_EN_COMP1, INT_EN_COMP2	Comparator Input Interrupt Generation Control Register	Go
24h	R/W	0h	INT_EN_CFG0	Global Interrupt Generation Control Register	Go
25h-32h	—	—	RESERVED	RESERVED	—

9.4.1 DEVICE_ID register (Offset = 1h) [reset = 20h]

DEVICE_ID is shown in [Figure 25](#) and described in [Table 7](#).

Return to [Summary Table](#).

This register represents the device ID of the TIC10024-Q1.

Figure 25. DEVICE_ID Register

23	22	21	20	19	18	17	16	15	14	13	12
RESERVED											
R-0h											
11	10	9	8	7	6	5	4	3	2	1	0
RESERVED	MAJOR						MINOR				
R-0h				R-12h				R-0h			

LEGEND: R = Read only

Table 7. DEVICE_ID Register Field Descriptions

Bit	Field	Type	Reset	Description
23-11	RESERVED	R	0h	RESERVED
10-4	MAJOR	R	12h	These 7 bits represents major revision ID. For TIC10024-Q1 the major revision ID is 12h.
3-0	MINOR	R	0h	These 4 bits represents minor revision ID. For TIC10024-Q1 the minor revision ID is 0h.

9.4.2 INT_STAT Register (Offset = 2h) [reset = 1h]

INT_STAT is shown in [Figure 26](#) and described in [Table 8](#).

Return to [Summary Table](#).

This register records the information of the event as it occurs in the device. A READ command executed on this register clears its content and resets the register to its default value. The $\overline{\text{INT}}$ pin is released at the rising edge of the $\overline{\text{CS}}$ pin from the READ command.

Figure 26. INT_STAT Register

23	22	21	20	19	18	17	16
RESERVED							
R-0h							
15	14	13	12	11	10	9	8
RESERVED		CHK_FAIL	RESERVED				CRC_CALC
R-0h		RC-0h	R-0h				RC-0h
7	6	5	4	3	2	1	0
UV	OV	TW	TSD	SSC	PRTY_FAIL	SPI_FAIL	POR
RC-0h	RC-0h	RC-0h	RC-0h	RC-0h	RC-0h	RC-0h	RC-1h

LEGEND: R = Read only; RC = Read to clear

Table 8. INT_STAT Register Field Descriptions

Bit	Field	Type	Reset	Description
23-14	RESERVED	R	0h	RESERVED
13	CHK_FAIL	RC	0h	<p>0h = Default factory setting is successfully loaded upon device initialization or the event status got cleared after a READ command was executed on the INT_STAT register.</p> <p>1h = An error is detected when loading factory settings into the device upon device initialization.</p> <p>During device initialization, factory settings are programmed into the device to allow proper device operation. The device performs a self-check after the device is programmed to diagnose whether correct settings are loaded. If the self-check returns an error, the CHK_FAIL bit is flagged to logic 1 along with the POR bit. The host controller is then recommended to initiate a software reset (see section Software Reset) to re-initialize the device and allow correct settings to be re-programmed.</p>
12-9	RESERVED	R	0h	RESERVED
8	CRC_CALC	RC	0h	<p>0h = CRC calculation is running, not started, or was acknowledged after a READ command was executed on the INT_STAT register.</p> <p>1h = CRC calculation is finished.</p> <p>CRC calculation (see section Cyclic Redundancy Check (CRC)) can be triggered to make sure correct register values are programmed into the device. Once the calculation is completed, the CRC_CALC bit is flagged to logic 1 to indicate completion of the calculation, and the result can then be accessed from the CRC (offset = 3h) register.</p>
7	UV	RC	0h	<p>0h = No under-voltage condition occurred or cleared on the V_S pin, or the event status got cleared after a READ command was executed on the INT_STAT register.</p> <p>1h = Under-voltage condition occurred or cleared on the V_S pin.</p> <p>When the UV bit is flagged to logic 1, it indicates the Under-Voltage (UV) event has occurred. The bit is also flagged to logic 1 when the event clears. For more details about the UV operation, please refer to section VS under-voltage (UV) condition.</p>

Table 8. INT_STAT Register Field Descriptions (continued)

Bit	Field	Type	Reset	Description
6	OV	RC	0h	<p>0h = No over-voltage condition occurred or cleared on the V_S pin, or the event status got cleared after a READ command was executed on the INT_STAT register.</p> <p>1h = Over-voltage condition occurred or cleared on the V_S pin.</p> <p>When the OV bit is flagged to logic 1, it indicates the Over-Voltage (OV) event has occurred. The bit is also flagged to logic 1 when the event clears. For more details about the OV operation, please refer to section VS over-voltage (OV) condition.</p>
5	TW	RC	0h	<p>0h = No temperature warning event occurred or the event status got cleared after a READ command was executed on the INT_STAT register.</p> <p>1h = Temperature warning event occurred or cleared.</p> <p>When the TW bit is flagged to logic 1, it indicates the temperature warning event has occurred. The bit is also flagged to logic 1 when the event clears. For more details about the temperature warning operation, please refer to section Temperature Warning (TW)</p>
4	TSD	RC	0h	<p>0h = No temperature Shutdown event occurred or the event status got cleared after a READ command was executed on the INT_STAT register.</p> <p>1h = Temperature Shutdown event occurred or cleared.</p> <p>When the TSD bit is flagged to logic 1, it indicates the temperature shutdown event has occurred. The bit is also flagged to logic 1 when the event clears. For more details about the temperature shutdown operation, please refer to section Temperature shutdown (TSD)</p>
3	SSC	RC	0h	<p>0h = No switch state change occurred or the status got cleared after a READ command was executed on the INT_STAT register.</p> <p>1h = Switch state change occurred.</p> <p>The Switch State Change (SSC) bit indicates whether input threshold crossing has occurred from switch inputs IN0 to IN23. This bit is also flagged to logic 1 after the first polling cycle is completed after device polling is triggered.</p>
2	PRTY_FAIL	RC	0h	<p>0h = No parity error occurred in the last received SI stream or the error status got cleared after a READ command was executed on the INT_STAT register.</p> <p>1h = Parity error occurred.</p> <p>When the PRTY_FAIL bit is flagged to logic 1, it indicates the last SPI Slave In (SI) transaction has a parity error. The device uses odd parity. If the total number of ones in the received data (including the parity bit) is an even number, the received data is discarded. The value of this register bit is mirrored to the PRTY_FLAG SPI status flag.</p>
1	SPI_FAIL	RC	0h	<p>0h = 32 clock pulse during a \overline{CS} = low sequence was detected or the error status got cleared after a READ command was executed on the INT_STAT register.</p> <p>1h = SPI error occurred</p> <p>When the SPI_FAIL bit is flagged to logic 1, it indicates the last SPI Slave In (SI) transaction is invalid. To program a complete word, 32 bits of information must be entered into the device. The SPI logic counts the number of bits clocked into the IC and enables data latching only if exactly 32 bits have been clocked in. In case the word length exceeds or does not meet the required length, the SPI_FAIL bit is flagged to logic 1, and the data received is considered invalid. The value of this register bit is mirrored to the SPI_FLAG SPI status flag. Note the SPI_FAIL bit is not flagged if SCLK is not present.</p>

Table 8. INT_STAT Register Field Descriptions (continued)

Bit	Field	Type	Reset	Description
0	POR	RC	1h	<p>0h = no Power-On-Reset (POR) event occurred or the status got cleared after a READ command was executed on the INT_STAT register.</p> <p>1h = Power-On-Reset (POR) event occurred.</p> <p>The Power-On-Reset (POR) interrupt bit indicates whether a reset event has occurred. A reset event sets the registers to their default values and re-initializes the device state machine. This bit is asserted after a successful power-on-reset, hardware reset, or software reset. The value of this register bit is mirrored to the POR SPI status flag.</p>

9.4.3 CRC Register (Offset = 3h) [reset = FFFFh]

CRC is shown in [Figure 27](#) and described in [Table 9](#).

Return to [Summary Table](#).

This register returns the CRC-16-CCCIT calculation result. The microcontroller can compare this value with its own calculated value to ensure correct register settings are programmed to the device.

Figure 27. CRC Register

23	22	21	20	19	18	17	16	15	14	13	12	11	10	9	8	7	6	5	4	3	2	1	0
RESERVED								CRC															
R-0h								R-FFFFh															

LEGEND: R = Read only

Table 9. CRC Register Field Descriptions

Bit	Field	Type	Reset	Description
23-16	RESERVED	R	0h	Reserved
15-0	CRC	R	FFFFh	CRC-16-CCITT calculation result: Bit1: LSB of CRC Bit16: MSB of CRC

9.4.4 IN_STAT_MISC Register (Offset = 4h) [reset = 0h]

 IN_STAT_MISC is shown in [Figure 28](#) and described in [Table 10](#).

 Return to [Summary Table](#).

This register indicates current device status unrelated to switch input monitoring.

Figure 28. IN_STAT_MISC Register

23	22	21	20	19	18	17	16
RESERVED							
R-0h							
15	14	13	12	11	10	9	8
RESERVED							
R-0h							
7	6	5	4	3	2	1	0
RESERVED				UV_STAT	OV_STAT	TW_STAT	TSD_STAT
R-0h				R-0h	R-0h	R-0h	R-0h

Table 10. IN_STAT_MISC Register Field Descriptions

Bit	Field	Type	Reset	Description
23-4	RESERVED	R	0h	Reserved
3	UV_STAT	R	0h	0h = V_S voltage is above the under-voltage condition threshold. 1h = V_S voltage is below the under-voltage condition threshold.
2	OV_STAT	R	0h	0h = V_S voltage is below the over-voltage condition threshold. 1h = V_S voltage is above the over-voltage condition threshold.
1	TW_STAT	R	0h	0h = Device junction temperature is below the temperature warning threshold T_{TW} . 1h = Device junction temperature is above the temperature warning threshold T_{TW} .
0	TSD_STAT	R	0h	0h = Device junction temperature is below the temperature shutdown threshold T_{TSD} . 1h = Device junction temperature is above the temperature shutdown threshold T_{TSD} .

9.4.5 IN_STAT_COMP Register (Offset = 5h) [reset = 0h]

IN_STAT_COMP is shown in [Figure 29](#) and described in [Table 11](#).

Return to [Summary Table](#).

This register indicates whether an input is below or above the comparator threshold.

Figure 29. IN_STAT_COMP Register

23		22		21		20		19		18		17		16	
INC_23	INC_22	INC_21	INC_20	INC_19	INC_18	INC_17	INC_16	INC_15	INC_14	INC_13	INC_12	INC_11	INC_10	INC_9	INC_8
R-0h	R-0h	R-0h	R-0h	R-0h	R-0h	R-0h	R-0h	R-0h	R-0h	R-0h	R-0h	R-0h	R-0h	R-0h	R-0h
15		14		13		12		11		10		9		8	
INC_15	INC_14	INC_13	INC_12	INC_11	INC_10	INC_9	INC_8	INC_7	INC_6	INC_5	INC_4	INC_3	INC_2	INC_1	INC_0
R-0h	R-0h	R-0h	R-0h	R-0h	R-0h	R-0h	R-0h	R-0h	R-0h	R-0h	R-0h	R-0h	R-0h	R-0h	R-0h
7		6		5		4		3		2		1		0	
INC_7	INC_6	INC_5	INC_4	INC_3	INC_2	INC_1	INC_0	INC_7	INC_6	INC_5	INC_4	INC_3	INC_2	INC_1	INC_0
R-0h	R-0h	R-0h	R-0h	R-0h	R-0h	R-0h	R-0h	R-0h	R-0h	R-0h	R-0h	R-0h	R-0h	R-0h	R-0h

LEGEND: R = Read only

Table 11. IN_STAT_COMP Register Field Descriptions

Bit	Field	Type	Reset	Description
23	INC_23	R	0h	0h = Input IN23 is below the comparator threshold. 1h = Input IN23 is above the comparator threshold.
22	INC_22	R	0h	0h = Input IN22 is below the comparator threshold. 1h = Input IN22 is above the comparator threshold.
21	INC_21	R	0h	0h = Input IN21 is below the comparator threshold. 1h = Input IN21 is above the comparator threshold.
20	INC_20	R	0h	0h = Input IN20 is below the comparator threshold. 1h = Input IN20 is above the comparator threshold.
19	INC_19	R	0h	0h = Input IN19 is below the comparator threshold. 1h = Input IN19 is above the comparator threshold.
18	INC_18	R	0h	0h = Input IN18 is below the comparator threshold. 1h = Input IN18 is above the comparator threshold.
17	INC_17	R	0h	0h = Input IN17 is below the comparator threshold. 1h = Input IN17 is above the comparator threshold.
16	INC_16	R	0h	0h = Input IN16 is below the comparator threshold. 1h = Input IN16 is above the comparator threshold.
15	INC_15	R	0h	0h = Input IN15 is below the comparator threshold. 1h = Input IN15 is above the comparator threshold.
14	INC_14	R	0h	0h = Input IN14 is below the comparator threshold. 1h = Input IN14 is above the comparator threshold.
13	INC_13	R	0h	0h = Input IN13 is below the comparator threshold. 1h = Input IN13 is above the comparator threshold.
12	INC_12	R	0h	0h = Input IN12 is below the comparator threshold. 1h = Input IN12 is above the comparator threshold.
11	INC_11	R	0h	0h = Input IN11 is below the comparator threshold. 1h = Input IN11 is above the comparator threshold.
10	INC_10	R	0h	0h = Input IN10 is below the comparator threshold. 1h = Input IN10 is above the comparator threshold.

Table 11. IN_STAT_COMP Register Field Descriptions (continued)

Bit	Field	Type	Reset	Description
9	INC_9	R	0h	0h = Input IN9 is below the comparator threshold. 1h = Input IN9 is above the comparator threshold.
8	INC_8	R	0h	0h = Input IN8 is below the comparator threshold. 1h = Input IN8 is above the comparator threshold.
7	INC_7	R	0h	0h = Input IN7 is below the comparator threshold. 1h = Input IN7 is above the comparator threshold.
6	INC_6	R	0h	0h = Input IN6 is below the comparator threshold. 1h = Input IN6 is above the comparator threshold.
5	INC_5	R	0h	0h = Input IN5 is below the comparator threshold. 1h = Input IN5 is above the comparator threshold.
4	INC_4	R	0h	0h = Input IN4 is below the comparator threshold. 1h = Input IN4 is above the comparator threshold.
3	INC_3	R	0h	0h = Input IN3 is below the comparator threshold. 1h = Input IN3 is above the comparator threshold.
2	INC_2	R	0h	0h = Input IN2 is below the comparator threshold. 1h = Input IN2 is above the comparator threshold.
1	INC_1	R	0h	0h = Input IN1 is below the comparator threshold. 1h = Input IN1 is above the comparator threshold.
0	INC_0	R	0h	0h = Input IN0 is below the comparator threshold. 1h = Input IN0 is above the comparator threshold.

9.4.6 CONFIG Register (Offset = 1Ah) [reset = 0h]

CONFIG is shown in [Figure 30](#) and described in [Table 12](#).

Return to [Summary Table](#).

Figure 30. CONFIG Register

23	22	21	20	19	18	17	16
RESERVED							TW_CUR_DIS_CSI
R-0h							R/W-0h
15	14	13	12	11	10	9	8
DET_FILTER		TW_CUR_DIS_CSO	INT_CONFIG	TRIGGER	POLL_EN	CRC_T	POLL_ACT_TIME
R/W-0h		R/W-0h	R/W-0h	R/W-0h	R/W-0h	R/W-0h	R/W-0h
7	6	5	4	3	2	1	0
POLL_ACT_TIME			POLL_TIME				RESET
R/W-0h			R/W-0h				R/W-0h

LEGEND: R/W = Read/Write

Table 12. CONFIG Register Field Descriptions

Bit	Field	Type	Reset	Description
23-17	RESERVED	R	0h	Reserved
16	TW_CUR_DIS_CSI	R/W	0h	0h = Enable wetting current reduction (to 2 mA) for 10mA and 15mA settings upon TW event for all inputs enabled with CSI. 1h = Disable wetting current reduction (to 2 mA) for 10mA and 15mA settings upon TW event for all inputs enabled with CSI.
15-14	DET_FILTER	R/W	0h	For detailed descriptions for the detection filter, refer to section Detection Filter . 0h = every sample is valid and taken for threshold evaluation 1h = 2 consecutive and equal samples required to be valid data 2h = 3 consecutive and equal samples required to be valid data 3h = 4 consecutive and equal samples required to be valid data
13	TW_CUR_DIS_CSO	R/W	0h	0h = Enable wetting current reduction (to 2mA) for 10mA and 15mA settings upon TW event for all inputs enabled with CSO. 1h = Disable wetting current reduction (to 2mA) for 10mA and 15mA settings upon TW event for all inputs enabled with CSO.
12	INT_CONFIG	R/W	0h	For detailed descriptions for the $\overline{\text{INT}}$ pin assertion scheme, refer to section Interrupt Generation and /INT Assertion . 0h = $\overline{\text{INT}}$ pin assertion scheme set to static 1h = $\overline{\text{INT}}$ pin assertion scheme set to dynamic

Table 12. CONFIG Register Field Descriptions (continued)

Bit	Field	Type	Reset	Description
11	TRIGGER	R/W	0h	<p>When the TRIGGER bit is set to logic 1, normal device operation (wetting current activation and polling) starts. To stop device operation and keep the device in an idle state, de-assert this bit to 0. After device normal operation is triggered, if at any time the device setting needs to be re-configured, the microcontroller is required to first set the bit TRIGGER to logic 0 to stop device operation. Once the re-configuration is completed, the microcontroller can set the TRIGGER bit back to logic 1 to re-start device operation. If re-configuration is done on the fly without first stopping the device operation, false switch status could be reported and accidental interrupt might be issued. The following register bits are the exception and can be configured when TRIGGER bit is set to logic 1:</p> <ul style="list-style-type: none"> – TRIGGER (bit 11 of the CONFIG register) – CRC_T (bit 9 of the CONFIG register) – RESET (bit 0 of the CONFIG register) – The CCP_CFG1 register <p>0h = Stop TIC10024-Q1 from normal operation. 1h = Trigger TIC10024-Q1 normal operation</p>
10	POLL_EN	R/W	0h	<p>0h = Polling disabled. Device operates in continuous mode. 1h = Polling enabled and the device operates in one of the polling modes.</p>
9	CRC_T	R/W	0h	<p>Set this bit to 1 to trigger a CRC calculation on all the configuration register bits. Once triggered, it is strongly recommended the SPI master does not change the content of the configuration registers until the CRC calculation is completed to avoid erroneous CRC calculation result. The TIC10024-Q1 sets the CRC_CALC interrupt bit and asserts the $\overline{\text{INT}}$ pin low when the CRC calculation is completed. The calculated result will be available in the CRC register. This bit self-clears back to 0 after CRC calculation is executed.</p> <p>0h = no CRC calculation triggered 1h = trigger CRC calculation</p>
8-5	POLL_ACT_TIME	R/W	0h	<p>0h = 64μs 1h = 128μs 2h = 192μs 3h = 256μs 4h = 320μs 5h = 384μs 6h = 448μs 7h = 512μs 8h = 640μs 9h = 768μs Ah = 896μs Bh = 1024μs Ch = 2048μs Dh-15h = 512μs (most frequently-used setting)</p>

Table 12. CONFIG Register Field Descriptions (continued)

Bit	Field	Type	Reset	Description
4-1	POLL_TIME	R/W	0h	0h = 2ms 1h = 4ms 2h = 8ms 3h = 16ms 4h = 32ms 5h = 48ms 6h = 64ms 7h = 128ms 8h = 256ms 9h = 512ms Ah = 1024ms Bh = 2048ms Ch = 4096ms Dh-15h = 8ms (most frequently-used setting)
0	RESET	R/W	0h	0h = No reset 1h = Trigger software reset of the device.

9.4.7 IN_EN Register (Offset = 1Bh) [reset = 0h]

 IN_EN is shown in [Figure 31](#) and described in [Table 13](#).

 Return to [Summary Table](#).

Figure 31. IN_EN Register

23	22	21	20	19	18	17	16
IN_EN_23	IN_EN_22	IN_EN_21	IN_EN_20	IN_EN_19	IN_EN_18	IN_EN_17	IN_EN_16
R/W-0h	R/W-0h	R/W-0h	R/W-0h	R/W-0h	R/W-0h	R/W-0h	R/W-0h
15	14	13	12	11	10	9	8
IN_EN_15	IN_EN_14	IN_EN_13	IN_EN_12	IN_EN_11	IN_EN_10	IN_EN_9	IN_EN_8
R/W-0h	R/W-0h	R/W-0h	R/W-0h	R/W-0h	R/W-0h	R/W-0h	R/W-0h
7	6	5	4	3	2	1	0
IN_EN_7	IN_EN_6	IN_EN_5	IN_EN_4	IN_EN_3	IN_EN_2	IN_EN_1	IN_EN_0
R/W-0h	R/W-0h	R/W-0h	R/W-0h	R/W-0h	R/W-0h	R/W-0h	R/W-0h

LEGEND: R/W = Read/Write

Table 13. IN_EN Register Field Descriptions

Bit	Field	Type	Reset	Description
23	IN_EN_23	R/W	0h	0h = Input channel IN23 disabled. Polling sequence skips this channel 1h = Input channel IN23 enabled.
22	IN_EN_22	R/W	0h	0h = Input channel IN22 disabled. Polling sequence skips this channel 1h = Input channel IN22 enabled.
21	IN_EN_21	R/W	0h	0h = Input channel IN21 disabled. Polling sequence skips this channel 1h = Input channel IN21 enabled.
20	IN_EN_20	R/W	0h	0h = Input channel IN20 disabled. Polling sequence skips this channel 1h = Input channel IN20 enabled.
19	IN_EN_19	R/W	0h	0h = Input channel IN19 disabled. Polling sequence skips this channel 1h = Input channel IN19 enabled.
18	IN_EN_18	R/W	0h	0h = Input channel IN18 disabled. Polling sequence skips this channel 1h = Input channel IN18 enabled.
17	IN_EN_17	R/W	0h	0h = Input channel IN17 disabled. Polling sequence skips this channel 1h = Input channel IN17 enabled.
16	IN_EN_16	R/W	0h	0h = Input channel IN16 disabled. Polling sequence skips this channel 1h = Input channel IN16 enabled.
15	IN_EN_15	R/W	0h	0h = Input channel IN15 disabled. Polling sequence skips this channel 1h = Input channel IN15 enabled.
14	IN_EN_14	R/W	0h	0h = Input channel IN14 disabled. Polling sequence skips this channel 1h = Input channel IN14 enabled.
13	IN_EN_13	R/W	0h	0h = Input channel IN13 disabled. Polling sequence skips this channel 1h = Input channel IN13 enabled.

Table 13. IN_EN Register Field Descriptions (continued)

Bit	Field	Type	Reset	Description
12	IN_EN_12	R/W	0h	0h = Input channel IN12 disabled. Polling sequence skips this channel 1h = Input channel IN12 enabled.
11	IN_EN_11	R/W	0h	0h = Input channel IN11 disabled. Polling sequence skips this channel 1h = Input channel IN11 enabled.
10	IN_EN_10	R/W	0h	0h = Input channel IN10 disabled. Polling sequence skips this channel 1h = Input channel IN10 enabled.
9	IN_EN_9	R/W	0h	0h = Input channel IN9 disabled. Polling sequence skips this channel 1h = Input channel IN9 enabled.
8	IN_EN_8	R/W	0h	0h = Input channel IN8 disabled. Polling sequence skips this channel 1h = Input channel IN8 enabled.
7	IN_EN_7	R/W	0h	0h = Input channel IN7 disabled. Polling sequence skips this channel 1h = Input channel IN7 enabled.
6	IN_EN_6	R/W	0h	0h = Input channel IN6 disabled. Polling sequence skips this channel 1h = Input channel IN6 enabled.
5	IN_EN_5	R/W	0h	0h = Input channel IN5 disabled. Polling sequence skips this channel 1h = Input channel IN5 enabled.
4	IN_EN_4	R/W	0h	0h = Input channel IN4 disabled. Polling sequence skips this channel 1h = Input channel IN4 enabled.
3	IN_EN_3	R/W	0h	0h = Input channel IN3 disabled. Polling sequence skips this channel 1h = Input channel IN3 enabled.
2	IN_EN_2	R/W	0h	0h = Input channel IN2 disabled. Polling sequence skips this channel 1h = Input channel IN2 enabled.
1	IN_EN_1	R/W	0h	0h = Input channel IN1 disabled. Polling sequence skips this channel 1h = Input channel IN1 enabled.
0	IN_EN_0	R/W	0h	0h = Input channel IN0 disabled. Polling sequence skips this channel 1h = Input channel IN0 enabled.

9.4.8 CS_SELECT Register (Offset = 1Ch) [reset = 0h]

CS_SELECT is shown in [Figure 32](#) and described in [Table 14](#).

Return to [Summary Table](#).

Figure 32. CS_SELECT Register

23	22	21	20	19	18	17	16	15	14	13	12
RESERVED											
R-0h											
11	10	9	8	7	6	5	4	3	2	1	0
RESERVED	CS_IN9	CS_IN8	CS_IN7	CS_IN6	CS_IN5	CS_IN4	CS_IN3	CS_IN2	CS_IN1	CS_IN0	
R-0h	R/W-0h	R/W-0h	R/W-0h	R/W-0h	R/W-0h	R/W-0h	R/W-0h	R/W-0h	R/W-0h	R/W-0h	R/W-0h

LEGEND: R/W = Read/Write; R = Read only

Table 14. CS_SELECT Register Field Descriptions

Bit	Field	Type	Reset	Description
23-10	RESERVED	R	0h	Reserved
9	CS_IN9	R/W	0h	0h = Current Source (CSO) selected 1h = Current Sink (CSI) selected
8	CS_IN8	R/W	0h	0h = Current Source (CSO) selected 1h = Current Sink (CSI) selected
7	CS_IN7	R/W	0h	0h = Current Source (CSO) selected 1h = Current Sink (CSI) selected
6	CS_IN6	R/W	0h	0h = Current Source (CSO) selected 1h = Current Sink (CSI) selected
5	CS_IN5	R/W	0h	0h = Current Source (CSO) selected 1h = Current Sink (CSI) selected
4	CS_IN4	R/W	0h	0h = Current Source (CSO) selected 1h = Current Sink (CSI) selected
3	CS_IN3	R/W	0h	0h = Current Source (CSO) selected 1h = Current Sink (CSI) selected
2	CS_IN2	R/W	0h	0h = Current Source (CSO) selected 1h = Current Sink (CSI) selected
1	CS_IN1	R/W	0h	0h = Current Source (CSO) selected 1h = Current Sink (CSI) selected
0	CS_IN0	R/W	0h	0h = Current Source (CSO) selected 1h = Current Sink (CSI) selected

9.4.9 WC_CFG0 Register (Offset = 1Dh) [reset = 0h]

WC_CFG0 is shown in [Figure 33](#) and described in [Table 15](#).

Return to [Summary Table](#).

Figure 33. WC_CFG0 Register

23	22	21	20	19	18	17	16	15	14	13	12
WC_IN11			WC_IN10			WC_IN8_IN9			WC_IN6_IN7		
R/W-0h			R/W-0h			R/W-0h			R/W-0h		
11	10	9	8	7	6	5	4	3	2	1	0
WC_IN5			WC_IN4			WC_IN2_IN3			WC_IN0_IN1		
R/W-0h			R/W-0h			R/W-0h			R/W-0h		

LEGEND: R/W = Read/Write

Table 15. WC_CFG0 Register Field Descriptions

Bit	Field	Type	Reset	Description
23-21	WC_IN11	R/W	0h	0h = no wetting current 1h = 1mA (typ.) wetting current 2h = 2mA (typ.) wetting current 3h = 5mA (typ.) wetting current 4h = 10mA (typ.) wetting current 5h-7h = 15mA (typ.) wetting current
20-18	WC_IN10	R/W	0h	0h = no wetting current 1h = 1mA (typ.) wetting current 2h = 2mA (typ.) wetting current 3h = 5mA (typ.) wetting current 4h = 10mA (typ.) wetting current 5h-7h = 15mA (typ.) wetting current
17-15	WC_IN8_IN9	R/W	0h	0h = no wetting current 1h = 1mA (typ.) wetting current 2h = 2mA (typ.) wetting current 3h = 5mA (typ.) wetting current 4h = 10mA (typ.) wetting current 5h-7h = 15mA (typ.) wetting current
14-12	WC_IN6_IN7	R/W	0h	0h = no wetting current 1h = 1mA (typ.) wetting current 2h = 2mA (typ.) wetting current 3h = 5mA (typ.) wetting current 4h = 10mA (typ.) wetting current 5h-7h = 15mA (typ.) wetting current
11-9	WC_IN5	R/W	0h	0h = no wetting current 1h = 1mA (typ.) wetting current 2h = 2mA (typ.) wetting current 3h = 5mA (typ.) wetting current 4h = 10mA (typ.) wetting current 5h-7h = 15mA (typ.) wetting current
8-6	WC_IN4	R/W	0h	0h = no wetting current 1h = 1mA (typ.) wetting current 2h = 2mA (typ.) wetting current 3h = 5mA (typ.) wetting current 4h = 10mA (typ.) wetting current 5h-7h = 15mA (typ.) wetting current

Table 15. WC_CFG0 Register Field Descriptions (continued)

Bit	Field	Type	Reset	Description
5-3	WC_IN2_IN3	R/W	0h	0h = no wetting current 1h = 1mA (typ.) wetting current 2h = 2mA (typ.) wetting current 3h = 5mA (typ.) wetting current 4h = 10mA (typ.) wetting current 5h-7h = 15mA (typ.) wetting current
2-0	WC_IN0_IN1	R/W	0h	0h = no wetting current 1h = 1mA (typ.) wetting current 2h = 2mA (typ.) wetting current 3h = 5mA (typ.) wetting current 4h = 10mA (typ.) wetting current 5h-7h = 15mA (typ.) wetting current

9.4.10 WC_CFG1 Register (Offset = 1Eh) [reset = 0h]

WC_CFG1 is shown in Figure 34 and described in Table 16.

Return to [Summary Table](#).

Figure 34. WC_CFG1 Register

23	22	21	20	19	18	17	16	15	14	13	12
RESERVED	AUTO_SCALE_DIS_CSI	AUTO_SCALE_DIS_CSO	WC_IN23			WC_IN22			WC_IN20_IN21		
R-0h	R/W-0h	R/W-0h	R/W-0h			R/W-0h			R/W-0h		
11	10	9	8	7	6	5	4	3	2	1	0
WC_IN18_IN19			WC_IN16_IN17			WC_IN14_IN15			WC_IN12_IN13		
R/W-0h			R/W-0h			R/W-0h			R/W-0h		

LEGEND: R/W = Read/Write; R = Read only

Table 16. WC_CFG1 Register Field Descriptions

Bit	Field	Type	Reset	Description
24-23	RESERVED	R	0h	Reserved
22	AUTO_SCALE_DIS_CSI	R/W	0h	0h = Enable wetting current auto-scaling (to 2mA) in continuous mode for 10mA and 15mA settings upon switch closure for all inputs enabled with CSI 1h = Disable wetting current auto-scaling (to 2mA) in continuous mode for 10mA and 15mA settings upon switch closure for all inputs enabled with CS For detailed descriptions for the wetting current auto-scaling, refer to section Wetting Current Auto-Scaling .
21	AUTO_SCALE_DIS_CSO	R/W	0h	0h = Enable wetting current auto-scaling (to 2mA) in continuous mode for 10mA and 15mA settings upon switch closure for all inputs enabled with CSO 1h = Disable wetting current auto-scaling (to 2mA) in continuous mode for 10mA and 15mA settings upon switch closure for all inputs enabled with CSO For detailed descriptions for the wetting current auto-scaling, refer to section Wetting Current Auto-Scaling .
20-18	WC_IN23	R/W	0h	0h = no wetting current 1h = 1mA (typ.) wetting current 2h = 2mA (typ.) wetting current 3h = 5mA (typ.) wetting current 4h = 10mA (typ.) wetting current 5h-7h = 15mA (typ.) wetting current
17-15	WC_IN22	R/W	0h	0h = no wetting current 1h = 1mA (typ.) wetting current 2h = 2mA (typ.) wetting current 3h = 5mA (typ.) wetting current 4h = 10mA (typ.) wetting current 5h-7h = 15mA (typ.) wetting current
14-12	WC_IN20_IN21	R/W	0h	0h = no wetting current 1h = 1mA (typ.) wetting current 2h = 2mA (typ.) wetting current 3h = 5mA (typ.) wetting current 4h = 10mA (typ.) wetting current 5h-7h = 15mA (typ.) wetting current

Table 16. WC_CFG1 Register Field Descriptions (continued)

Bit	Field	Type	Reset	Description
11-9	WC_IN18_IN19	R/W	0h	0h = no wetting current 1h = 1mA (typ.) wetting current 2h = 2mA (typ.) wetting current 3h = 5mA (typ.) wetting current 4h = 10mA (typ.) wetting current 5h-7h = 15mA (typ.) wetting current
8-6	WC_IN16_IN17	R/W	0h	0h = no wetting current 1h = 1mA (typ.) wetting current 2h = 2mA (typ.) wetting current 3h = 5mA (typ.) wetting current 4h = 10mA (typ.) wetting current 5h-7h = 15mA (typ.) wetting current
5-3	WC_IN14_IN15	R/W	0h	0h = no wetting current 1h = 1mA (typ.) wetting current 2h = 2mA (typ.) wetting current 3h = 5mA (typ.) wetting current 4h = 10mA (typ.) wetting current 5h-7h = 15mA (typ.) wetting current
2-0	WC_IN12_IN13	R/W	0h	0h = no wetting current 1h = 1mA (typ.) wetting current 2h = 2mA (typ.) wetting current 3h = 5mA (typ.) wetting current 4h = 10mA (typ.) wetting current 5h-7h = 15mA (typ.) wetting current

9.4.11 CCP_CFG0 Register (Offset = 1Fh) [reset = 0h]

CCP_CFG0 is shown in [Figure 35](#) and described in [Table 17](#).

Return to [Summary Table](#).

Figure 35. CCP_CFG0 Register

23	22	21	20	19	18	17	16	15	14	13	12
RESERVED											
R-0h											
11	10	9	8	7	6	5	4	3	2	1	0
RESERVED				CCP_TIME				WC_CCP 3	WC_CCP 2	WC_CCP 1	WC_CCP 0
R-0h				R-0h				R-0h	R-0h	R-0h	R-0h

LEGEND: R/W = Read/Write; R = Read only

Table 17. CCP_CFG0 Register Field Descriptions

Bit	Field	Type	Reset	Description
23-7	RESERVED	R	0h	Reserved
6-4	CCP_TIME	R/W	0h	Wetting current activation time in CCP mode 0h = 64µs 1h = 128µs 2h = 192µs 3h = 256µs 4h = 320µs 5h = 384µs 6h = 448µs 7h = 512µs
3	WC_CCP3	R/W	0h	Wetting current setting for IN18 to IN23 in CCP mode 0h = 10mA (typ.) wetting current 1h = 15mA (typ.) wetting current
2	WC_CCP2	R/W	0h	Wetting current setting for IN12 to IN17 in CCP mode 0h = 10mA (typ.) wetting current 1h = 15mA (typ.) wetting current
1	WC_CCP1	R/W	0h	Wetting current setting for IN6 to IN11 in CCP mode 0h = 10mA (typ.) wetting current 1h = 15mA (typ.) wetting current
0	WC_CCP0	R/W	0h	Wetting current setting for IN0 to IN5 in CCP mode 0h = 10mA (typ.) wetting current 1h = 15mA (typ.) wetting current

9.4.12 CCP_CFG1 Register (Offset = 20h) [reset = 0h]

 CCP_CFG1 is shown in [Figure 36](#) and described in [Table 18](#).

 Return to [Summary Table](#).

Figure 36. CCP_CFG1 Register

23		22		21		20		19		18		17		16	
CCP_IN23	CCP_IN22	CCP_IN21	CCP_IN20	CCP_IN19	CCP_IN18	CCP_IN17	CCP_IN16	CCP_IN15	CCP_IN14	CCP_IN13	CCP_IN12	CCP_IN11	CCP_IN10	CCP_IN9	CCP_IN8
R/W-0h	R/W-0h	R/W-0h	R/W-0h	R/W-0h	R/W-0h	R/W-0h	R/W-0h	R/W-0h	R/W-0h	R/W-0h	R/W-0h	R/W-0h	R/W-0h	R/W-0h	R/W-0h
15		14		13		12		11		10		9		8	
CCP_IN15	CCP_IN14	CCP_IN13	CCP_IN12	CCP_IN11	CCP_IN10	CCP_IN9	CCP_IN8	CCP_IN7	CCP_IN6	CCP_IN5	CCP_IN4	CCP_IN3	CCP_IN2	CCP_IN1	CCP_IN0
R/W-0h	R/W-0h	R/W-0h	R/W-0h	R/W-0h	R/W-0h	R/W-0h	R/W-0h	R/W-0h	R/W-0h	R/W-0h	R/W-0h	R/W-0h	R/W-0h	R/W-0h	R/W-0h
7		6		5		4		3		2		1		0	
CCP_IN7	CCP_IN6	CCP_IN5	CCP_IN4	CCP_IN3	CCP_IN2	CCP_IN1	CCP_IN0	CCP_IN0	CCP_IN0	CCP_IN0	CCP_IN0	CCP_IN0	CCP_IN0	CCP_IN0	CCP_IN0
R/W-0h	R/W-0h	R/W-0h	R/W-0h	R/W-0h	R/W-0h	R/W-0h	R/W-0h	R/W-0h	R/W-0h	R/W-0h	R/W-0h	R/W-0h	R/W-0h	R/W-0h	R/W-0h

LEGEND: R/W = Read/Write

Table 18. CCP_CFG1 Register Field Descriptions

Bit	Field	Type	Reset	Description
23	CCP_IN23	R/W	0h	0h = no CCP wetting current 1h = CCP wetting current activated
22	CCP_IN22	R/W	0h	0h = no CCP wetting current 1h = CCP wetting current activated
21	CCP_IN21	R/W	0h	0h = no CCP wetting current 1h = CCP wetting current activated
20	CCP_IN20	R/W	0h	0h = no CCP wetting current 1h = CCP wetting current activated
19	CCP_IN19	R/W	0h	0h = no CCP wetting current 1h = CCP wetting current activated
18	CCP_IN18	R/W	0h	0h = no CCP wetting current 1h = CCP wetting current activated
17	CCP_IN17	R/W	0h	0h = no CCP wetting current 1h = CCP wetting current activated
16	CCP_IN16	R/W	0h	0h = no CCP wetting current 1h = CCP wetting current activated
15	CCP_IN15	R/W	0h	0h = no CCP wetting current 1h = CCP wetting current activated
14	CCP_IN14	R/W	0h	0h = no CCP wetting current 1h = CCP wetting current activated
13	CCP_IN13	R/W	0h	0h = no CCP wetting current 1h = CCP wetting current activated
12	CCP_IN12	R/W	0h	0h = no CCP wetting current 1h = CCP wetting current activated
11	CCP_IN11	R/W	0h	0h = no CCP wetting current 1h = CCP wetting current activated
10	CCP_IN10	R/W	0h	0h = no CCP wetting current 1h = CCP wetting current activated

Table 18. CCP_CFG1 Register Field Descriptions (continued)

Bit	Field	Type	Reset	Description
9	CCP_IN9	R/W	0h	0h = no CCP wetting current 1h = CCP wetting current activated
8	CCP_IN8	R/W	0h	0h = no CCP wetting current 1h = CCP wetting current activated
7	CCP_IN7	R/W	0h	0h = no CCP wetting current 1h = CCP wetting current activated
6	CCP_IN6	R/W	0h	0h = no CCP wetting current 1h = CCP wetting current activated
5	CCP_IN5	R/W	0h	0h = no CCP wetting current 1h = CCP wetting current activated
4	CCP_IN4	R/W	0h	0h = no CCP wetting current 1h = CCP wetting current activated
3	CCP_IN3	R/W	0h	0h = no CCP wetting current 1h = CCP wetting current activated
2	CCP_IN2	R/W	0h	0h = no CCP wetting current 1h = CCP wetting current activated
1	CCP_IN1	R/W	0h	0h = no CCP wetting current 1h = CCP wetting current activated
0	CCP_IN0	R/W	0h	0h = no CCP wetting current 1h = CCP wetting current activated

9.4.13 THRES_COMP Register (Offset = 21h) [reset = 0h]

 THRES_COMP is shown in [Figure 37](#) and described in [Table 19](#).

 Return to [Summary Table](#).

Figure 37. THRES_COMP Register

23	22	21	20	19	18	17	16
RESERVED							
R-0h							
15	14	13	12	11	10	9	8
RESERVED				THRES_COMP_IN20_IN23		THRES_COMP_IN16_IN19	
R-0h				R/W-0h		R/W-0h	
7	6	5	4	3	2	1	0
THRES_COMP_IN12_IN15		THRES_COMP_IN8_IN11		THRES_COMP_IN4_IN7		THRES_COMP_IN0_IN3	
R/W-0h		R/W-0h		R/W-0h		R/W-0h	

LEGEND: R/W = Read/Write; R = Read only

Table 19. THRES_COMP Register Field Descriptions

Bit	Field	Type	Reset	Description
31-12	RESERVED	R	0h	Reserved
11-10	THRES_COMP_IN20_IN23	R/W	0h	These 2 bits configures the comparator thresholds for input channels IN20 to IN23 0h = comparator threshold set to 2V 1h = comparator threshold set to 2.7V 2h = comparator threshold set to 3V 3h = comparator threshold set to 4V
9-8	THRES_COMP_IN16_IN19	R/W	0h	These 2 bits configures the comparator thresholds for input channels IN16 to IN19 0h = comparator threshold set to 2V 1h = comparator threshold set to 2.7V 2h = comparator threshold set to 3V 3h = comparator threshold set to 4V
7-6	THRES_COMP_IN12_IN15	R/W	0h	These 2 bits configures the comparator thresholds for input channels IN12 to IN15 0h = comparator threshold set to 2V 1h = comparator threshold set to 2.7V 2h = comparator threshold set to 3V 3h = comparator threshold set to 4V
5-4	THRES_COMP_IN8_IN11	R/W	0h	These 2 bits configures the comparator thresholds for input channels IN8 to IN11 0h = comparator threshold set to 2V 1h = comparator threshold set to 2.7V 2h = comparator threshold set to 3V 3h = comparator threshold set to 4V
3-2	THRES_COMP_IN4_IN7	R/W	0h	These 2 bits configures the comparator thresholds for input channels IN4 to IN7 0h = comparator threshold set to 2V 1h = comparator threshold set to 2.7V 2h = comparator threshold set to 3V 3h = comparator threshold set to 4V

Table 19. THRES_COMP Register Field Descriptions (continued)

Bit	Field	Type	Reset	Description
1-0	THRES_COMP_IN0_IN3	R/W	0h	These 2 bits configures the comparator thresholds for input channels IN0 to IN3 0h = comparator threshold set to 2V 1h = comparator threshold set to 2.7V 2h = comparator threshold set to 3V 3h = comparator threshold set to 4V

9.4.14 INT_EN_COMP1 Register (Offset = 22h) [reset = 0h]

 INT_EN_COMP1 is shown in [Figure 38](#) and described in [Table 20](#).

 Return to [Summary Table](#).

Figure 38. INT_EN_COMP1 Register

23	22	21	20	19	18	17	16	15	14	13	12
INC_EN_11		INC_EN_10		INC_EN_9		INC_EN_8		INC_EN_7		INC_EN_6	
R/W-0h		R/W-0h		R/W-0h		R/W-0h		R/W-0h		R/W-0h	
11	10	9	8	7	6	5	4	3	2	1	0
INC_EN_5		INC_EN_4		INC_EN_3		INC_EN_2		INC_EN_1		INC_EN_0	
R/W-0h		R/W-0h		R/W-0h		R/W-0h		R/W-0h		R/W-0h	

LEGEND: R/W = Read/Write

Table 20. INT_EN_COMP1 Register Field Descriptions

Bit	Field	Type	Reset	Description
23-22	INC_EN_11	R/W	0h	0h = no interrupt generation for IN11 1h = interrupt generation on rising edge above THRES_COMP_IN8_IN11 for IN11 2h = interrupt generation on falling edge below THRES_COMP_IN8_IN11 for IN11 3h = interrupt generation on falling and rising edge of THRES_COMP_IN8_IN11 for IN11
21-20	INC_EN_10	R/W	0h	0h = no interrupt generation for IN10 1h = interrupt generation on rising edge above THRES_COMP_IN8_IN11 for IN10 2h = interrupt generation on falling edge below THRES_COMP_IN8_IN11 for IN10 3h = interrupt generation on falling and rising edge of THRES_COMP_IN8_IN11 for IN10
19-18	INC_EN_9	R/W	0h	0h = no interrupt generation for IN9 1h = interrupt generation on rising edge above THRES_COMP_IN8_IN11 for IN9 2h = interrupt generation on falling edge below THRES_COMP_IN8_IN11 for IN9 3h = interrupt generation on falling and rising edge of THRES_COMP_IN8_IN11 for IN9
17-16	INC_EN_8	R/W	0h	0h = no interrupt generation for IN8 1h = interrupt generation on rising edge above THRES_COMP_IN8_IN11 for IN8 2h = interrupt generation on falling edge below THRES_COMP_IN8_IN11 for IN8 3h = interrupt generation on falling and rising edge of THRES_COMP_IN8_IN11 for IN8
15-14	INC_EN_7	R/W	0h	0h = no interrupt generation for IN7 1h = interrupt generation on rising edge above THRES_COMP_IN4_IN7 for IN7 2h = interrupt generation on falling edge below THRES_COMP_IN4_IN7 for IN7 3h = interrupt generation on falling and rising edge of THRES_COMP_IN4_IN7 for IN7

Table 20. INT_EN_COMP1 Register Field Descriptions (continued)

Bit	Field	Type	Reset	Description
13-12	INC_EN_6	R/W	0h	0h = no interrupt generation for IN6 1h = interrupt generation on rising edge above THRES_COMP_IN4_IN7 for IN6 2h = interrupt generation on falling edge below THRES_COMP_IN4_IN7 for IN6 3h = interrupt generation on falling and rising edge of THRES_COMP_IN4_IN7 for IN6
11-10	INC_EN_5	R/W	0h	0h = no interrupt generation for IN5 1h = interrupt generation on rising edge above THRES_COMP_IN4_IN7 for IN5 2h = interrupt generation on falling edge below THRES_COMP_IN4_IN7 for IN5 3h = interrupt generation on falling and rising edge of THRES_COMP_IN4_IN7 for IN5
9-8	INC_EN_4	R/W	0h	0h = no interrupt generation for IN4 1h = interrupt generation on rising edge above THRES_COMP_IN4_IN7 for IN4 2h = interrupt generation on falling edge below THRES_COMP_IN4_IN7 for IN4 3h = interrupt generation on falling and rising edge of THRES_COMP_IN4_IN7 for IN4
7-6	INC_EN_3	R/W	0h	0h = no interrupt generation for IN3 1h = interrupt generation on rising edge above THRES_COMP_IN0_IN3 for IN3 2h = interrupt generation on falling edge below THRES_COMP_IN0_IN3 for IN3 3h = interrupt generation on falling and rising edge of THRES_COMP_IN0_IN3 for IN3
5-4	INC_EN_2	R/W	0h	0h = no interrupt generation for IN2 1h = interrupt generation on rising edge above THRES_COMP_IN0_IN3 for IN2 2h = interrupt generation on falling edge below THRES_COMP_IN0_IN3 for IN2 3h = interrupt generation on falling and rising edge of THRES_COMP_IN0_IN3 for IN2
3-2	INC_EN_1	R/W	0h	0h = no interrupt generation for IN1 1h = interrupt generation on rising edge above THRES_COMP_IN0_IN3 for IN1 2h = interrupt generation on falling edge below THRES_COMP_IN0_IN3 for IN1 3h = interrupt generation on falling and rising edge of THRES_COMP_IN0_IN3 for IN1
1-0	INC_EN_0	R/W	0h	0h = no interrupt generation for IN0 1h = interrupt generation on rising edge above THRES_COMP_IN0_IN3 for IN0 2h = interrupt generation on falling edge below THRES_COMP_IN0_IN3 for IN0 3h = interrupt generation on falling and rising edge of THRES_COMP_IN0_IN3 for IN0

9.4.15 INT_EN_COMP2 Register (Offset = 23h) [reset = 0h]

 INT_EN_COMP2 is shown in [Figure 39](#) and described in [Table 21](#).

 Return to [Summary Table](#).

Figure 39. INT_EN_COMP2 Register

23	22	21	20	19	18	17	16	15	14	13	12
INC_EN_23		INC_EN_22		INC_EN_21		INC_EN_20		INC_EN_19		INC_EN_18	
R/W-0h		R/W-0h		R/W-0h		R/W-0h		R/W-0h		R/W-0h	
11	10	9	8	7	6	5	4	3	2	1	0
INC_EN_17		INC_EN_16		INC_EN_15		INC_EN_14		INC_EN_13		INC_EN_12	
R/W-0h		R/W-0h		R/W-0h		R/W-0h		R/W-0h		R/W-0h	

LEGEND: R/W = Read/Write

Table 21. INT_EN_COMP2 Register Field Descriptions

Bit	Field	Type	Reset	Description
23-22	INC_EN_23	R/W	0h	0h = no interrupt generation for IN23 1h = interrupt generation on rising edge above THRES_COMP_IN20_IN23 for IN23 2h = interrupt generation on falling edge below THRES_COMP_IN20_IN23 for IN23 3h = interrupt generation on falling and rising edge of THRES_COMP_IN20_IN23 for IN23
21-20	INC_EN_22	R/W	0h	0h = no interrupt generation for IN22 1h = interrupt generation on rising edge above THRES_COMP_IN20_IN23 for IN22 2h = interrupt generation on falling edge below THRES_COMP_IN20_IN23 for IN22 3h = interrupt generation on falling and rising edge of THRES_COMP_IN20_IN23 for IN22
19-18	INC_EN_21	R/W	0h	0h = no interrupt generation for IN21 1h = interrupt generation on rising edge above THRES_COMP_IN20_IN23 for IN21 2h = interrupt generation on falling edge below THRES_COMP_IN20_IN23 for IN21 3h = interrupt generation on falling and rising edge of THRES_COMP_IN20_IN23 for IN21
17-16	INC_EN_20	R/W	0h	0h = no interrupt generation for IN20 1h = interrupt generation on rising edge above THRES_COMP_IN20_IN23 for IN20 2h = interrupt generation on falling edge below THRES_COMP_IN20_IN23 for IN20 3h = interrupt generation on falling and rising edge of THRES_COMP_IN20_IN23 for IN20
15-14	INC_EN_19	R/W	0h	0h = no interrupt generation for IN19 1h = interrupt generation on rising edge above THRES_COMP_IN16_IN19 for IN19 2h = interrupt generation on falling edge below THRES_COMP_IN16_IN19 for IN19 3h = interrupt generation on falling and rising edge of THRES_COMP_IN16_IN19 for IN19

Table 21. INT_EN_COMP2 Register Field Descriptions (continued)

Bit	Field	Type	Reset	Description
13-12	INC_EN_18	R/W	0h	0h = no interrupt generation for IN18 1h = interrupt generation on rising edge above THRES_COMP_IN16_IN19 for IN18 2h = interrupt generation on falling edge below THRES_COMP_IN16_IN19 for IN18 3h = interrupt generation on falling and rising edge of THRES_COMP_IN16_IN19 for IN18
11-10	INC_EN_17	R/W	0h	0h = no interrupt generation for IN17 1h = interrupt generation on rising edge above THRES_COMP_IN16_IN19 for IN17 2h = interrupt generation on falling edge below THRES_COMP_IN16_IN19 for IN17 3h = interrupt generation on falling and rising edge of THRES_COMP_IN16_IN19 for IN17
9-8	INC_EN_16	R/W	0h	0h = no interrupt generation for IN16 1h = interrupt generation on rising edge above THRES_COMP_IN16_IN19 for IN16 2h = interrupt generation on falling edge below THRES_COMP_IN16_IN19 for IN16 3h = interrupt generation on falling and rising edge of THRES_COMP_IN16_IN19 for IN16
7-6	INC_EN_15	R/W	0h	0h = no interrupt generation for IN15 1h = interrupt generation on rising edge above THRES_COMP_IN12_IN15 for IN15 2h = interrupt generation on falling edge below THRES_COMP_IN12_IN15 for IN15 3h = interrupt generation on falling and rising edge of THRES_COMP_IN12_IN15 for IN15
5-4	INC_EN_14	R/W	0h	0h = no interrupt generation for IN14 1h = interrupt generation on rising edge above THRES_COMP_IN12_IN15 for IN14 2h = interrupt generation on falling edge below THRES_COMP_IN12_IN15 for IN14 3h = interrupt generation on falling and rising edge of THRES_COMP_IN12_IN15 for IN14
3-2	INC_EN_13	R/W	0h	0h = no interrupt generation for IN13 1h = interrupt generation on rising edge above THRES_COMP_IN12_IN15 for IN13 2h = interrupt generation on falling edge below THRES_COMP_IN12_IN15 for IN13 3h = interrupt generation on falling and rising edge of THRES_COMP_IN12_IN15 for IN13
1-0	INC_EN_12	R/W	0h	0h = no interrupt generation for IN12 1h = interrupt generation on rising edge above THRES_COMP_IN12_IN15 for IN12 2h = interrupt generation on falling edge below THRES_COMP_IN12_IN15 for IN12 3h = interrupt generation on falling and rising edge of THRES_COMP_IN12_IN15 for IN12

9.4.16 INT_EN_CFG0 Register (Offset = 24h) [reset = 0h]

 INT_EN_CFG0 is shown in [Figure 40](#) and described in [Table 22](#).

 Return to [Summary Table](#).

Figure 40. INT_EN_CFG0 Register

23	22	21	20	19	18	17	16
RESERVED							
R-0h							
15	14	13	12	11	10	9	8
RESERVED							
R-0h							
7	6	5	4	3	2	1	0
CRC_CALC_EN	UV_EN	OV_EN	TW_EN	TSD_EN	SSC_EN	PRTY_FAIL_EN	SPI_FAIL_EN
R/W-0h	R/W-0h	R/W-0h	R/W-0h	R/W-0h	R/W-0h	R/W-0h	R/W-0h

LEGEND: R/W = Read/Write; R = Read only

Table 22. INT_EN_CFG0 Register Field Descriptions

Bit	Field	Type	Reset	Description
23-8	RESERVED	R	0h	Reserved
7	CRC_CALC_EN	R/W	0h	0h = $\overline{\text{INT}}$ pin assertion due to CRC calculation completion disabled. 1h = $\overline{\text{INT}}$ pin assertion due to CRC calculation completion enabled.
6	UV_EN	R/W	0h	0h = $\overline{\text{INT}}$ pin assertion due to UV event disabled. 1h = $\overline{\text{INT}}$ pin assertion due to UV event enabled.
5	OV_EN	R/W	0h	0h = $\overline{\text{INT}}$ pin assertion due to OV event disabled. 1h = $\overline{\text{INT}}$ pin assertion due to OV event enabled.
4	TW_EN	R/W	0h	0h = $\overline{\text{INT}}$ pin assertion due to TW event disabled. 1h = $\overline{\text{INT}}$ pin assertion due to TW event enabled.
3	TSD_EN	R/W	0h	0h = $\overline{\text{INT}}$ pin assertion due to TSD event disabled. 1h = $\overline{\text{INT}}$ pin assertion due to TSD event enabled.
2	SSC_EN	R/W	0h	0h = $\overline{\text{INT}}$ pin assertion due to SSC event disabled. 1h = $\overline{\text{INT}}$ pin assertion due to SSC event enabled.
1	PRTY_FAIL_EN	R/W	0h	0h = $\overline{\text{INT}}$ pin assertion due to parity fail event disabled. 1h = $\overline{\text{INT}}$ pin assertion due to parity fail event enabled.
0	SPI_FAIL_EN	R/W	0h	0h = $\overline{\text{INT}}$ pin assertion due to SPI fail event disabled. 1h = $\overline{\text{INT}}$ pin assertion due to SPI fail event enabled.

10 Application and Implementation

NOTE

Information in the following applications sections is not part of the TI component specification, and TI does not warrant its accuracy or completeness. TI's customers are responsible for determining suitability of components for their purposes. Customers should validate and test their design implementation to confirm system functionality.

10.1 Application Information

The TIC10024-Q1 is an advanced 24-input Multiple Switch Detection Interface (MSDI) device designed to detect external mechanical switch status in a 12-V automotive system by acting as an interface between the switches and the low-voltage microcontroller. The device offers a number of unique features to replace systems implemented with discrete components, saving board space and reducing the bill of materials (BOM). The device can also be configured into low-power polling mode, which provides significant savings on system power consumption.

10.2 Digital Switch Detection in Automotive Body Control Module

The body control module (BCM) is an electronic control unit responsible for monitoring and controlling various electronic accessories in a vehicle body. Detection of various mechanical switches status in a vehicle is one important task handled by the BCM. Most switches inside the BCM are digital in nature, meaning they have either an ON or an OFF state. The TIC10024-Q1 can detect up to 24 digital switches. The following application diagram depicts how the TIC10024-Q1 is used in a BCM to detect an external digital switch and a detailed design example is shown in the following sections.

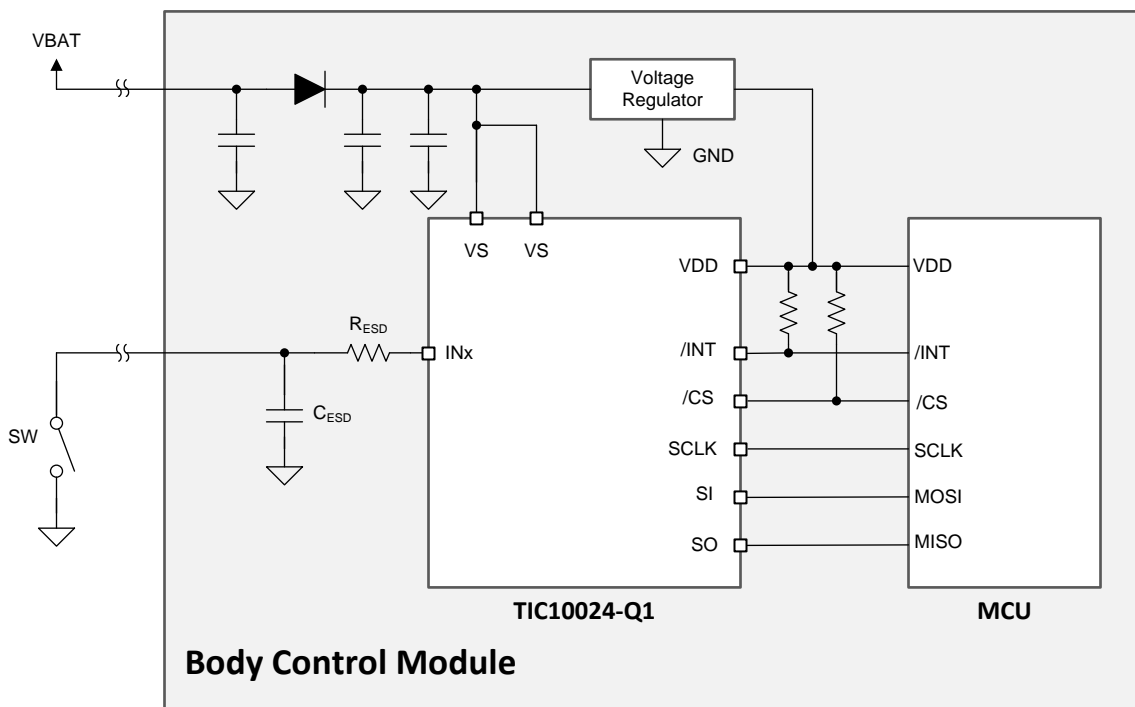

Copyright © 2016, Texas Instruments Incorporated

Figure 41. Using TIC10024-Q1 to Monitor a Digital Switch in Body Control Module Application

Digital Switch Detection in Automotive Body Control Module (continued)

10.2.1 Design Requirements

Table 23. Example Digital Switch Specification

PARAMETER	SPECIFICATION	MIN	MAX
V_{BAT}	$7\text{ V} \leq V_{BAT} \leq 16\text{ V}$	7 V	16 V
V_{DIODE} (voltage drop across the reverse-blocking diode)	$0\text{ V} \leq V_{DIODE} \leq 1\text{ V}$	0 V	1 V
R_{ESD}	$50\ \Omega \pm 8\%$	46 Ω	54 Ω
R_{SW}	220 Ω Max when closed $\pm 8\%$	0 Ω	237.6 Ω
R_{DIRT}	5000 Ω Min	5000 Ω	∞
Wetting current requirement	10mA Typical		

An example of digital switch connected to ground shown in [Figure 41](#), with [Table 23](#) summarizing its detailed requirements. The goal of this design is to utilize the TIC10024-Q1's integrated comparator to detect and differentiate between the 2 switch states:

1. State 1: SW open
2. State 2: SW closed

To mimic real automotive systems, the battery is assumed to be fluctuating between 7 V and 16 V. Taking into account the voltage drop across the reverse-blocking diode, the V_S supply voltage to the TIC10024-Q1 device can fluctuate between 6 V and 16 V. R_{DIRT} is introduced to model the small leakage flowing across the switch in open state. When the switch changes position and the switch state changes from one to another, the TIC10024-Q1 is required to correctly detect the state transition and issue an interrupt to alert the microcontroller. The switch information needs to be stored in the status registers for the microcontroller to retrieve.

10.2.2 Detailed Design Procedure

Table 24. Detailed Design Procedure

	STEP 1		STEP 2	
	Equivalent Resistance Value (Ω)		V_{INX} (V)	
	MIN	MAX	MIN	MAX
State 1: SW open	5000	∞	>10	-
State 2: SW closed	0	291.6	0	3.32

Use the following procedures to calculate thresholds to program to the TIC10024-Q1 for proper switch detection:

1. Calculate the equivalent resistance values at the 2 switch states, taking into account R_{DIRT} and the 8% resistance variation.
2. Estimate the voltage established when wetting current flows through the switch by utilizing the relationship $V_{INX} = R_{SW_EQU} \times I_{WETT_ACT}$, where R_{SW_EQU} is the equivalent switch resistance value and I_{WETT_ACT} is the actual wetting current flowing through the switch. The 10 mA wetting current setting is selected in this design as required by the specification. The wetting current variation, however, can occur depending on manufacturing process variation and operating temperature, and needs to be taken into account. Referring to the electrical table of the TIC10024-Q1 and assuming enough headroom for the current source (CSO) to operate, the 10mA wetting current setting produces current ranging between 8.4 mA and 11.4 mA (for $6\text{ V} \leq V_S \leq 35\text{ V}$ condition). The voltage established on the TIC10024-Q1 input pin (V_{INX}) can be calculated accordingly.
3. After the V_{INX} voltage is calculated for the 2 switch states, the proper threshold value needs to be chosen between minimum V_{INX} voltage of state 1 (>10 V) and maximum V_{INX} voltage of state 2 (3.32 V). The TIC10024-Q1 has 4 thresholds that can be configured for the comparator: 2 V, 2.7 V, 3 V, and 4 V. As a result, the proper threshold to be used in this design example is 4 V.
4. To properly program the device, follow the below recommend procedure:
 - Enable channel IN0 by setting IN_EN_0 bit to 1 in the IN_EN register
 - Program the wetting current to source by setting CS_IN0 bit to 0 in the CS SELECT register

- Program the wetting current to 10 mA by configuring WC_IN0_IN1 bits to 100 in the WC_CFG0 register
- Disable wetting current auto-scaling by setting AUTO_SCALE_DIS_CSO bit in WC_CFG1 register to 1
- Program the comparator threshold to 4 V by setting the THRES_COMP_IN0_IN3 bits to 11 in the THRES_COMP register
- Program interrupt generation to both rising and falling transitions by setting the INC_EN_0 bits to 11 in the INT_EN_COMP1 register
- Enable interrupt generation from switch state change by setting the SSC bit to 1 in the INT_EN_CFG0 register
- Program the CONFIG register: Keep the device in continuous mode by setting the POLL_EN bit to 0. Start device operation by setting the TRIGGER bit to 1.
- Read the INT_STAT register to clear the baseline SSC interrupt once the interrupt is observed.
- Toggle the external switch open and monitor the $\overline{\text{INT}}$ pin. Read the INT_STAT register and IN_STATE_COMP register to make sure the correct switch status is reported.

10.2.3 Application Curves

Figure 42 is the scope shot showing the switch getting toggled from close to open at time a). Before toggling, the voltage at V_{IN0} stays low at roughly 2.7 V. Once the switch opens, the voltage at V_{IN0} gets pulled high to the V_{S} voltage. The $\overline{\text{INT}}$ pin is asserted shortly after the switch toggles at time b) to notify the microcontroller an switch state change event has occurred.

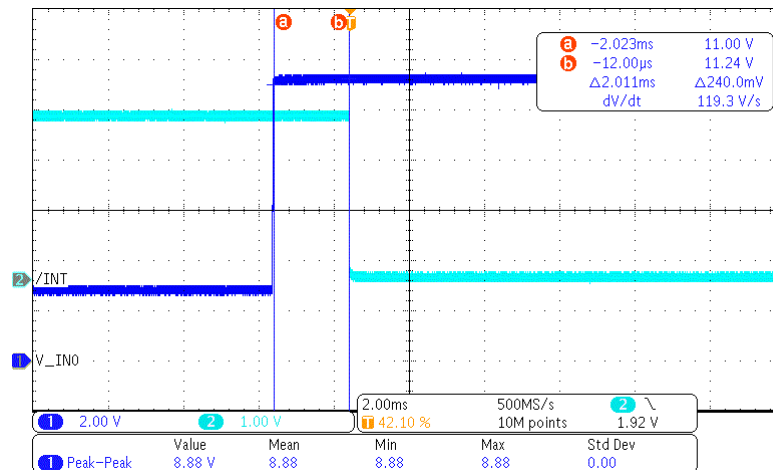
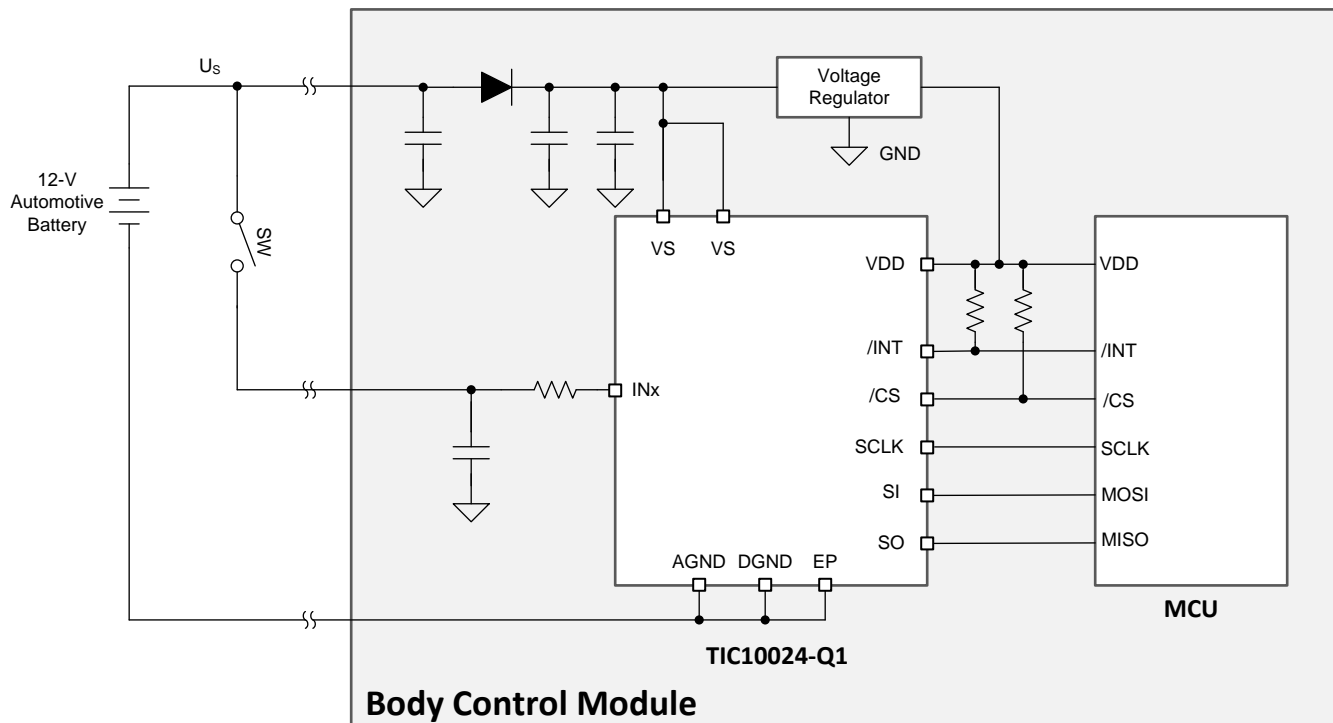

Figure 42. Measured Waveform Showing V_{IN0} Pin and $\overline{\text{INT}}$ Pin Voltages

10.3 Systems Examples

10.3.1 Using TIC10024-Q1 in a 12 V Automotive System



Copyright © 2016, Texas Instruments Incorporated

Figure 43. Typical System Diagram of Battery Connections for TIC10024-Q1

The TIC10024-Q1 is designed to operate with a 12 V automotive system. [Figure 43](#) depicts a typical system diagram to show how the device is connected to the battery. Care must be taken when connecting the battery directly to the device on the V_S supply pin (through a reverse-blocking diode) or the input (IN_x) pins since an automotive battery can be subjected to various transient and over-voltage events. Manufacturers have independently created standards and test procedures in an effort to prevent sensitive electronics from failing due to these events. Recently, combined efforts are made with ISO to develop the ISO 16750-2 standard (Road vehicles -- Environmental conditions and testing for electrical and electronic equipment -- Part 2: Electrical loads), which describe the possible transients that could occur to an automotive battery and specify test methods to simulate them.

It shall be noted that the TIC10024-Q1 is designed and tested according to the ISO 16750-2 standard. A few voltage stress tests and their test conditions are listed below. Exposing the device to more severe transient events than described by the standard could potentially causes performance degradation and long-term damage to the device.

- Direct current supply voltage: $V_{BAT, \min} = 6 \text{ V}$; $V_{BAT, \max} = 16 \text{ V}$
- To emulate a jump start event, voltage profile described in [Figure 44](#) is used.

Systems Examples (continued)

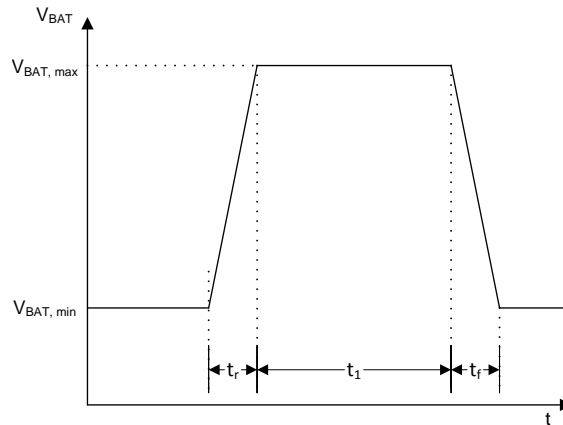

Figure 44. Voltage Profile to Test a Jump Start Event

Table 25. Voltage Profile Parameters to Test a Jump Start Event

Parameter	Value
$V_{BAT, min}$	10.8 V
$V_{BAT, max}$	24 V
t_r	< 10 ms
t_1	$60\text{ s} \pm 6\text{ s}$
t_f	< 10 ms
Number of cycles	1

- To emulate a load dump event for an alternator with centralized load dump suppression, voltage profile described in Figure 45 is used. U_A and U_S^* are applied directly to V_{BAT} .

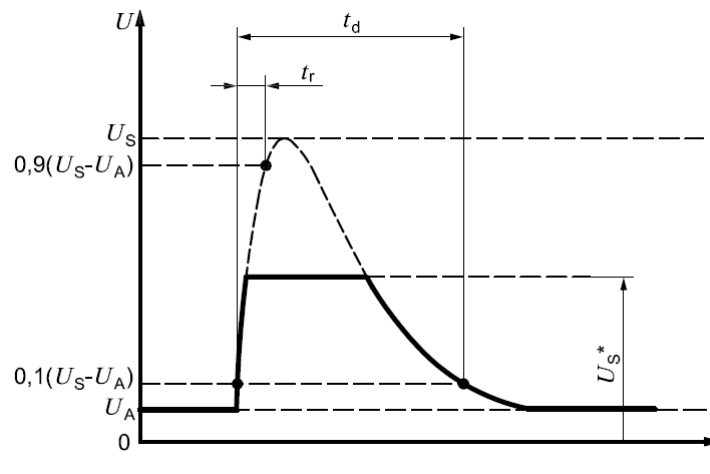

Figure 45. Voltage Profile to Test a Load Dump Event With Centralized Load Dump Suppression

Table 26. Voltage Profile to Test a Load Dump Event With Centralized Load Dump Suppression

Parameter	Value
U_A	13.5 V
U_S	$79\text{ V} \leq U_S \leq 101$
U_{S^*}	35 V
t_d	$40\text{ ms} \leq t_d \leq 400\text{ ms}$
t_r	< 10 ms
Number of cycles	5 pulses at intervals of 1 min

- To emulate a cranking event, voltage profile describe in [Figure 46](#) is used. U_S , U_{S6} , and U_A are applied directly to V_{BAT} .

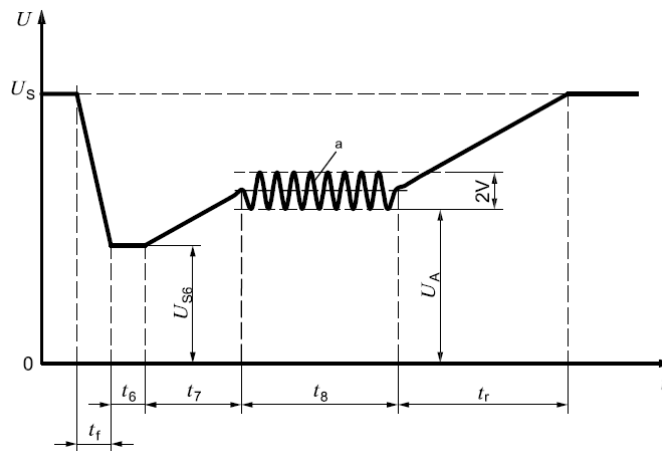

Figure 46. Voltage Profile to Test a Cranking Event

Table 27. Voltage Profile Used to Test a Cranking Event

Parameter	Value - Level I	Value - Level II	Value - Level IV
U_{S6}	8 V	4.5 V	6 V
U_S	9.5 V	6.5 V	6.5 V
U_A	$14\text{ V} \pm 0.2\text{ V}$	$14\text{ V} \pm 0.2\text{ V}$	$14\text{ V} \pm 0.2\text{ V}$
t_f	$5\text{ ms} \pm 0.5\text{ ms}$	$5\text{ ms} \pm 0.5\text{ ms}$	$5\text{ ms} \pm 0.5\text{ ms}$
t_6	$15\text{ ms} \pm 1.5\text{ ms}$	$15\text{ ms} \pm 1.5\text{ ms}$	$15\text{ ms} \pm 1.5\text{ ms}$
t_7	$50\text{ ms} \pm 5\text{ ms}$	$50\text{ ms} \pm 5\text{ ms}$	$50\text{ ms} \pm 5\text{ ms}$
t_8	$1000\text{ ms} \pm 100\text{ ms}$	$10000\text{ ms} \pm 1000\text{ ms}$	$10000\text{ ms} \pm 1000\text{ ms}$
t_r	$40\text{ ms} \pm 4\text{ ms}$	$100\text{ ms} \pm 10\text{ ms}$	$100\text{ ms} \pm 10\text{ ms}$

11 Power Supply Recommendations

There are two supply input pins for the TIC10024-Q1: V_S and V_{DD} . V_S is the main power supply for the entire chip and is essential for all critical functions of the device. The V_S supply is designed to be connected to a 12-V automotive battery (through a reverse blocking diode) with nominal operating voltage no greater than 16V. The V_{DD} supply is used to determine the logic level on the SPI communication interface, source the current for the SO driver, and sets the pull-up voltage for the /CS pin. It can also be used as a possible external pull-up supply for the /INT pin as an alternative to the V_S supply and it shall be connected to a 3 V to 5.5 V logic supply. Removing V_{DD} from the device disables SPI communications, but does not impact normal operation of the device.

To improve stability of the supply inputs, some decoupling capacitors are recommended on the PCB. Figure 47 shows an example on the on-board power supply decoupling scheme. The battery voltage (V_{BAT}) is decoupled on the Electronic Control Unit (ECU) board using a large decoupling capacitor (C_{BUFF}). The diode is installed to prevent damage to the internal system under reversed battery condition. C_{VS} shall be installed close to the TIC10024-Q1 for best decoupling performance. The voltage regulator provides a regulated voltage for the digital portion of the device and for the local microcontroller and its output is decoupled with $C_{DECOUPLE}$. Table 28 lists recommended values for each individual decoupling capacitor shown in the system diagram.

Table 28. Decoupling Capacitor Recommendations

CRC RULE	VALUE
C_{BUFF}	100 μ F, 50 V rated, $\pm 20\%$
C_{VBAT}	100 nF, 50V rated, $\pm 10\%$; X7R
C_{VS}	100 nF, 50 V rated
$C_{DECOUPLE}$	100 nF–1 μ F

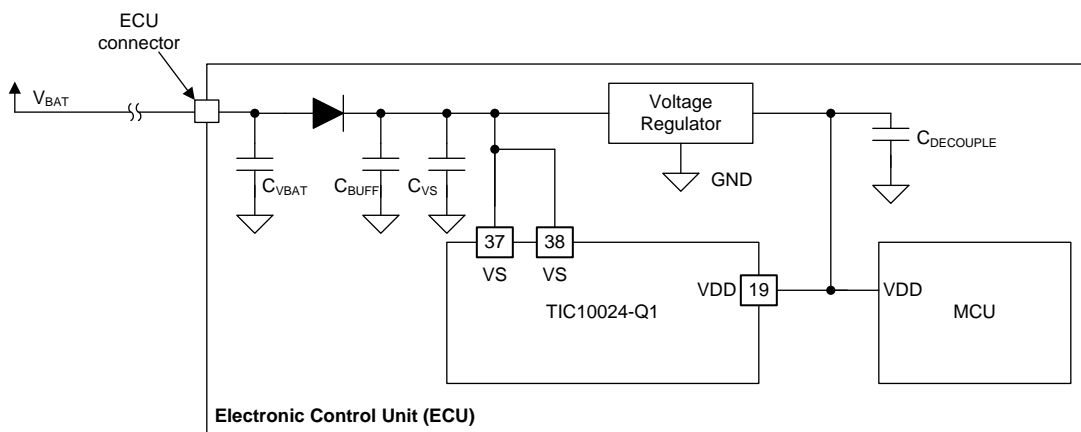

Copyright © 2016, Texas Instruments Incorporated

Figure 47. Recommended Power Supply Decoupling

12 Layout

12.1 Layout Guidelines

Figure 48 illustrates an example of a PCB layout with the TIC10024-Q1. Some key considerations are:

1. Decouple the V_S and V_{DD} pins with capacitor using recommended values from section [Power Supply Recommendations](#) and place them as close to the pin as possible. Make sure that the capacitor voltage rating is sufficient for the V_S and V_{DD} supplies.
2. Keep the input lines as short as possible.
3. Use a solid ground plane to help distribute heat and reduce electromagnetic interference (EMI) noise pickup.
4. Do not run sensitive analog traces in parallel with digital traces. Avoid crossing digital and analog traces if possible, and only make perpendicular crossings when necessary.
5. To achieve good thermal performance, the exposed thermal pad underneath the device must be soldered to the board and flooded with VIAs to ground planes. For simple double-sided PCBs where there are no internal layers, the surface layers can be used to remove heat. For multilayer PCBs, internal ground planes can be used for heat removal.
7. Minimize the inductive parasitic between the IN_x input capacitors and the thermal pad ground return.

13 Device and Documentation Support

13.1 Receiving Notification of Documentation Updates

To receive notification of documentation updates, navigate to the device product folder on ti.com. In the upper right corner, click on *Alert me* to register and receive a weekly digest of any product information that has changed. For change details, review the revision history included in any revised document.

13.2 Community Resources

The following links connect to TI community resources. Linked contents are provided "AS IS" by the respective contributors. They do not constitute TI specifications and do not necessarily reflect TI's views; see TI's [Terms of Use](#).

TI E2E™ Online Community *TI's Engineer-to-Engineer (E2E) Community*. Created to foster collaboration among engineers. At e2e.ti.com, you can ask questions, share knowledge, explore ideas and help solve problems with fellow engineers.

Design Support *TI's Design Support* Quickly find helpful E2E forums along with design support tools and contact information for technical support.

13.3 Trademarks

E2E is a trademark of Texas Instruments.

13.4 Electrostatic Discharge Caution



These devices have limited built-in ESD protection. The leads should be shorted together or the device placed in conductive foam during storage or handling to prevent electrostatic damage to the MOS gates.

13.5 Glossary

[SLYZ022](#) — *TI Glossary*.

This glossary lists and explains terms, acronyms, and definitions.

14 Mechanical, Packaging, and Orderable Information

The following pages include mechanical, packaging, and orderable information. This information is the most current data available for the designated devices. This data is subject to change without notice and revision of this document. For browser-based versions of this data sheet, refer to the left-hand navigation.

PACKAGING INFORMATION

Orderable Device	Status (1)	Package Type	Package Drawing	Pins	Package Qty	Eco Plan (2)	Lead/Ball Finish (6)	MSL Peak Temp (3)	Op Temp (°C)	Device Marking (4/5)	Samples
TIC10024QDCPRQ1	ACTIVE	HTSSOP	DCP	38	2000	Green (RoHS & no Sb/Br)	CU NIPDAU	Level-3-260C-168 HR	-40 to 125	TIC10024Q	Samples
TIC10024QDCPTQ1	PREVIEW	HTSSOP	DCP	38	2000	TBD	Call TI	Call TI	-40 to 125		

(1) The marketing status values are defined as follows:

ACTIVE: Product device recommended for new designs.

LIFEBUY: TI has announced that the device will be discontinued, and a lifetime-buy period is in effect.

NRND: Not recommended for new designs. Device is in production to support existing customers, but TI does not recommend using this part in a new design.

PREVIEW: Device has been announced but is not in production. Samples may or may not be available.

OBSELETE: TI has discontinued the production of the device.

(2) **RoHS:** TI defines "RoHS" to mean semiconductor products that are compliant with the current EU RoHS requirements for all 10 RoHS substances, including the requirement that RoHS substance do not exceed 0.1% by weight in homogeneous materials. Where designed to be soldered at high temperatures, "RoHS" products are suitable for use in specified lead-free processes. TI may reference these types of products as "Pb-Free".

RoHS Exempt: TI defines "RoHS Exempt" to mean products that contain lead but are compliant with EU RoHS pursuant to a specific EU RoHS exemption.

Green: TI defines "Green" to mean the content of Chlorine (Cl) and Bromine (Br) based flame retardants meet JS709B low halogen requirements of ≤ 1000 ppm threshold. Antimony trioxide based flame retardants must also meet the ≤ 1000 ppm threshold requirement.

(3) MSL, Peak Temp. - The Moisture Sensitivity Level rating according to the JEDEC industry standard classifications, and peak solder temperature.

(4) There may be additional marking, which relates to the logo, the lot trace code information, or the environmental category on the device.

(5) Multiple Device Markings will be inside parentheses. Only one Device Marking contained in parentheses and separated by a "~" will appear on a device. If a line is indented then it is a continuation of the previous line and the two combined represent the entire Device Marking for that device.

(6) Lead/Ball Finish - Orderable Devices may have multiple material finish options. Finish options are separated by a vertical ruled line. Lead/Ball Finish values may wrap to two lines if the finish value exceeds the maximum column width.

Important Information and Disclaimer: The information provided on this page represents TI's knowledge and belief as of the date that it is provided. TI bases its knowledge and belief on information provided by third parties, and makes no representation or warranty as to the accuracy of such information. Efforts are underway to better integrate information from third parties. TI has taken and continues to take reasonable steps to provide representative and accurate information but may not have conducted destructive testing or chemical analysis on incoming materials and chemicals. TI and TI suppliers consider certain information to be proprietary, and thus CAS numbers and other limited information may not be available for release.

In no event shall TI's liability arising out of such information exceed the total purchase price of the TI part(s) at issue in this document sold by TI to Customer on an annual basis.

TAPE AND REEL INFORMATION



QUADRANT ASSIGNMENTS FOR PIN 1 ORIENTATION IN TAPE



*All dimensions are nominal

Device	Package Type	Package Drawing	Pins	SPQ	Reel Diameter (mm)	Reel Width W1 (mm)	A0 (mm)	B0 (mm)	K0 (mm)	P1 (mm)	W (mm)	Pin1 Quadrant
TIC10024QDCPRQ1	HTSSOP	DCP	38	2000	330.0	16.4	6.9	10.2	1.8	12.0	16.0	Q1

TAPE AND REEL BOX DIMENSIONS



*All dimensions are nominal

Device	Package Type	Package Drawing	Pins	SPQ	Length (mm)	Width (mm)	Height (mm)
TIC10024QDCPRQ1	HTSSOP	DCP	38	2000	367.0	367.0	38.0

DCP (R-PDSO-G**) 30 PIN SHOWN

PowerPAD™ PLASTIC SMALL-OUTLINE PACKAGE

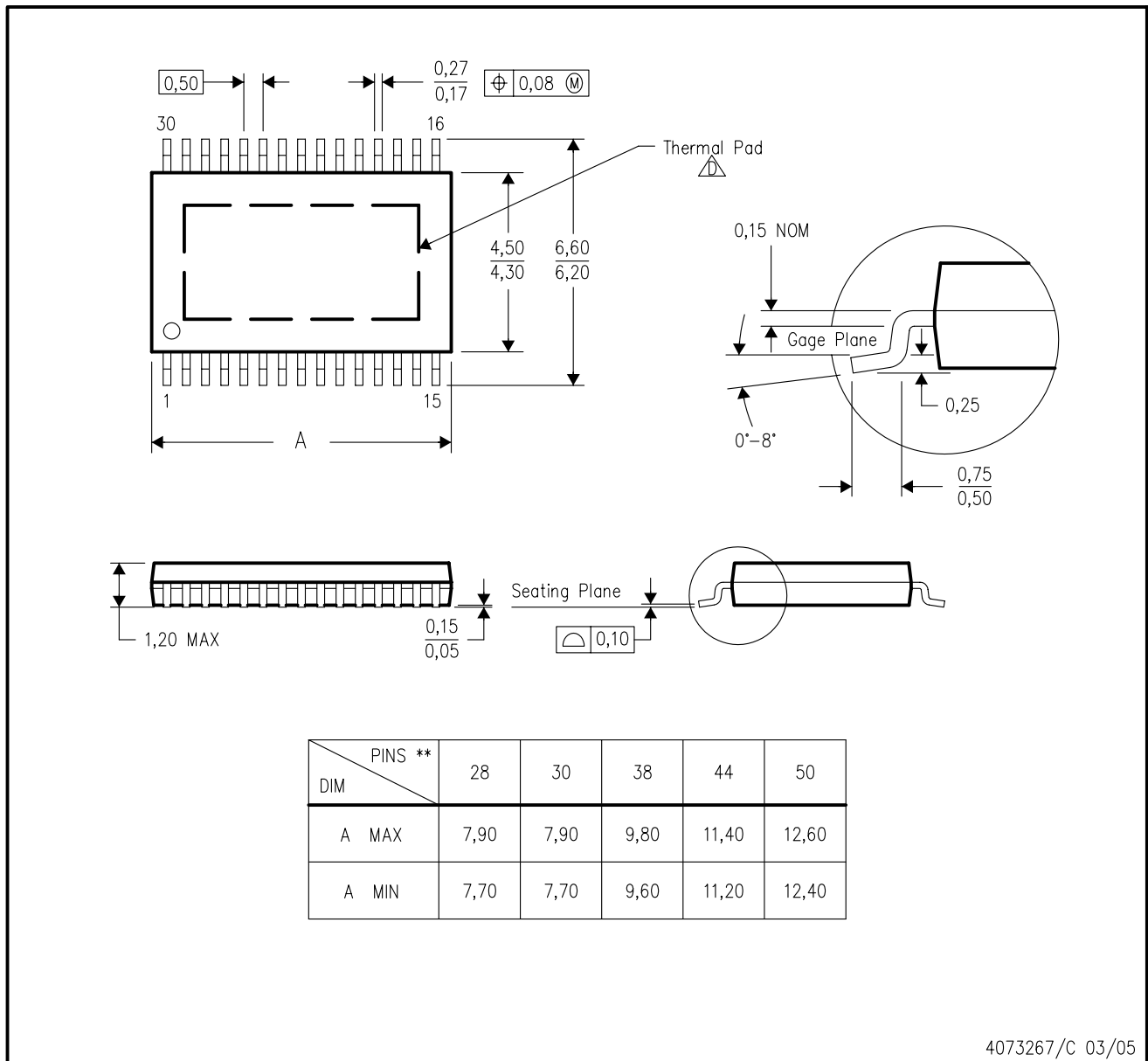

- NOTES:
- A. All linear dimensions are in millimeters.
 - B. This drawing is subject to change without notice.
 - C. Body dimensions do not include mold flash or protrusions, mold flash not to exceed 0.15mm.
 - △ This package is designed to be soldered to a thermal pad on the board. Refer to Technical Brief, PowerPad Thermally Enhanced Package, Texas Instruments Literature No. SLMA002 for information regarding recommended board layout. This document is available at www.ti.com. See the product data sheet for details regarding the exposed thermal pad dimensions.
 - E. Falls within JEDEC MO-153

PowerPAD is a trademark of Texas Instruments.

THERMAL INFORMATION

This PowerPAD™ package incorporates an exposed thermal pad that is designed to be attached to a printed circuit board (PCB). The thermal pad must be soldered directly to the PCB. After soldering, the PCB can be used as a heatsink. In addition, through the use of thermal vias, the thermal pad can be attached directly to the appropriate copper plane shown in the electrical schematic for the device, or alternatively, can be attached to a special heatsink structure designed into the PCB. This design optimizes the heat transfer from the integrated circuit (IC).

For additional information on the PowerPAD package and how to take advantage of its heat dissipating abilities, refer to Technical Brief, PowerPAD Thermally Enhanced Package, Texas Instruments Literature No. SLMA002 and Application Brief, PowerPAD Made Easy, Texas Instruments Literature No. SLMA004. Both documents are available at www.ti.com.

The exposed thermal pad dimensions for this package are shown in the following illustration.

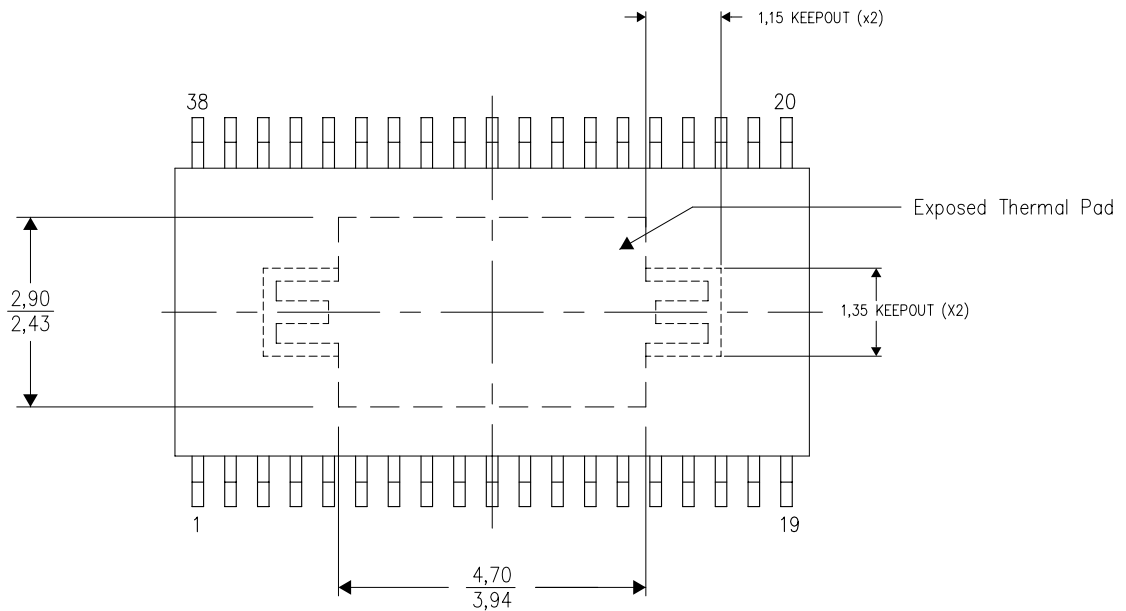

Top View

NOTE: All linear dimensions are in millimeters

Exposed Thermal Pad Dimensions

DCP (R-PDSO-G38) PowerPAD™

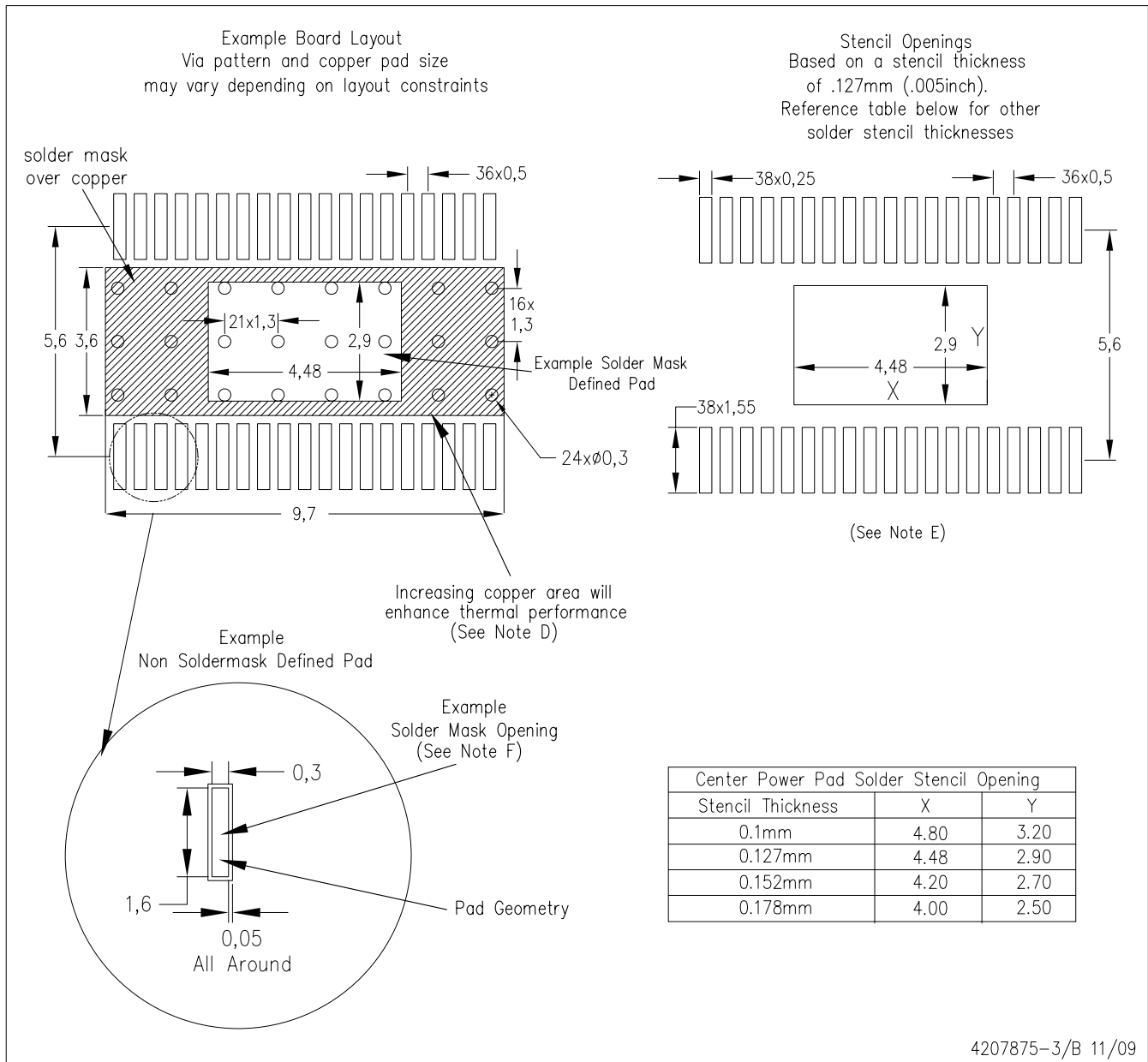

- NOTES:
- All linear dimensions are in millimeters.
 - This drawing is subject to change without notice.
 - Customers should place a note on the circuit board fabrication drawing not to alter the center solder mask defined pad.
 - This package is designed to be soldered to a thermal pad on the board. Refer to Technical Brief, PowerPad Thermally Enhanced Package, Texas Instruments Literature No. SLMA002, SLMA004, and also the Product Data Sheets for specific thermal information, via requirements, and recommended board layout. These documents are available at www.ti.com <<http://www.ti.com>>. Publication IPC-7351 is recommended for alternate designs.
 - Laser cutting apertures with trapezoidal walls and also rounding corners will offer better paste release. Customers should contact their board assembly site for stencil design recommendations. Example stencil design based on a 50% volumetric metal load solder paste. Refer to IPC-7525 for other stencil recommendations.
 - Customers should contact their board fabrication site for solder mask tolerances between and around signal pads.

PowerPAD is a trademark of Texas Instruments.

IMPORTANT NOTICE

Texas Instruments Incorporated (TI) reserves the right to make corrections, enhancements, improvements and other changes to its semiconductor products and services per JESD46, latest issue, and to discontinue any product or service per JESD48, latest issue. Buyers should obtain the latest relevant information before placing orders and should verify that such information is current and complete.

TI's published terms of sale for semiconductor products (<http://www.ti.com/sc/docs/stdterms.htm>) apply to the sale of packaged integrated circuit products that TI has qualified and released to market. Additional terms may apply to the use or sale of other types of TI products and services.

Reproduction of significant portions of TI information in TI data sheets is permissible only if reproduction is without alteration and is accompanied by all associated warranties, conditions, limitations, and notices. TI is not responsible or liable for such reproduced documentation. Information of third parties may be subject to additional restrictions. Resale of TI products or services with statements different from or beyond the parameters stated by TI for that product or service voids all express and any implied warranties for the associated TI product or service and is an unfair and deceptive business practice. TI is not responsible or liable for any such statements.

Buyers and others who are developing systems that incorporate TI products (collectively, "Designers") understand and agree that Designers remain responsible for using their independent analysis, evaluation and judgment in designing their applications and that Designers have full and exclusive responsibility to assure the safety of Designers' applications and compliance of their applications (and of all TI products used in or for Designers' applications) with all applicable regulations, laws and other applicable requirements. Designer represents that, with respect to their applications, Designer has all the necessary expertise to create and implement safeguards that (1) anticipate dangerous consequences of failures, (2) monitor failures and their consequences, and (3) lessen the likelihood of failures that might cause harm and take appropriate actions. Designer agrees that prior to using or distributing any applications that include TI products, Designer will thoroughly test such applications and the functionality of such TI products as used in such applications.

TI's provision of technical, application or other design advice, quality characterization, reliability data or other services or information, including, but not limited to, reference designs and materials relating to evaluation modules, (collectively, "TI Resources") are intended to assist designers who are developing applications that incorporate TI products; by downloading, accessing or using TI Resources in any way, Designer (individually or, if Designer is acting on behalf of a company, Designer's company) agrees to use any particular TI Resource solely for this purpose and subject to the terms of this Notice.

TI's provision of TI Resources does not expand or otherwise alter TI's applicable published warranties or warranty disclaimers for TI products, and no additional obligations or liabilities arise from TI providing such TI Resources. TI reserves the right to make corrections, enhancements, improvements and other changes to its TI Resources. TI has not conducted any testing other than that specifically described in the published documentation for a particular TI Resource.

Designer is authorized to use, copy and modify any individual TI Resource only in connection with the development of applications that include the TI product(s) identified in such TI Resource. NO OTHER LICENSE, EXPRESS OR IMPLIED, BY ESTOPPEL OR OTHERWISE TO ANY OTHER TI INTELLECTUAL PROPERTY RIGHT, AND NO LICENSE TO ANY TECHNOLOGY OR INTELLECTUAL PROPERTY RIGHT OF TI OR ANY THIRD PARTY IS GRANTED HEREIN, including but not limited to any patent right, copyright, mask work right, or other intellectual property right relating to any combination, machine, or process in which TI products or services are used. Information regarding or referencing third-party products or services does not constitute a license to use such products or services, or a warranty or endorsement thereof. Use of TI Resources may require a license from a third party under the patents or other intellectual property of the third party, or a license from TI under the patents or other intellectual property of TI.

TI RESOURCES ARE PROVIDED "AS IS" AND WITH ALL FAULTS. TI DISCLAIMS ALL OTHER WARRANTIES OR REPRESENTATIONS, EXPRESS OR IMPLIED, REGARDING RESOURCES OR USE THEREOF, INCLUDING BUT NOT LIMITED TO ACCURACY OR COMPLETENESS, TITLE, ANY EPIDEMIC FAILURE WARRANTY AND ANY IMPLIED WARRANTIES OF MERCHANTABILITY, FITNESS FOR A PARTICULAR PURPOSE, AND NON-INFRINGEMENT OF ANY THIRD PARTY INTELLECTUAL PROPERTY RIGHTS. TI SHALL NOT BE LIABLE FOR AND SHALL NOT DEFEND OR INDEMNIFY DESIGNER AGAINST ANY CLAIM, INCLUDING BUT NOT LIMITED TO ANY INFRINGEMENT CLAIM THAT RELATES TO OR IS BASED ON ANY COMBINATION OF PRODUCTS EVEN IF DESCRIBED IN TI RESOURCES OR OTHERWISE. IN NO EVENT SHALL TI BE LIABLE FOR ANY ACTUAL, DIRECT, SPECIAL, COLLATERAL, INDIRECT, PUNITIVE, INCIDENTAL, CONSEQUENTIAL OR EXEMPLARY DAMAGES IN CONNECTION WITH OR ARISING OUT OF TI RESOURCES OR USE THEREOF, AND REGARDLESS OF WHETHER TI HAS BEEN ADVISED OF THE POSSIBILITY OF SUCH DAMAGES.

Unless TI has explicitly designated an individual product as meeting the requirements of a particular industry standard (e.g., ISO/TS 16949 and ISO 26262), TI is not responsible for any failure to meet such industry standard requirements.

Where TI specifically promotes products as facilitating functional safety or as compliant with industry functional safety standards, such products are intended to help enable customers to design and create their own applications that meet applicable functional safety standards and requirements. Using products in an application does not by itself establish any safety features in the application. Designers must ensure compliance with safety-related requirements and standards applicable to their applications. Designer may not use any TI products in life-critical medical equipment unless authorized officers of the parties have executed a special contract specifically governing such use. Life-critical medical equipment is medical equipment where failure of such equipment would cause serious bodily injury or death (e.g., life support, pacemakers, defibrillators, heart pumps, neurostimulators, and implantables). Such equipment includes, without limitation, all medical devices identified by the U.S. Food and Drug Administration as Class III devices and equivalent classifications outside the U.S.

TI may expressly designate certain products as completing a particular qualification (e.g., Q100, Military Grade, or Enhanced Product). Designers agree that it has the necessary expertise to select the product with the appropriate qualification designation for their applications and that proper product selection is at Designers' own risk. Designers are solely responsible for compliance with all legal and regulatory requirements in connection with such selection.

Designer will fully indemnify TI and its representatives against any damages, costs, losses, and/or liabilities arising out of Designer's non-compliance with the terms and provisions of this Notice.