



COLOR TV EAST-WEST CORRECTION

FEATURES SUMMARY

- BUILD IN FRAME PARABOLA FROM EXTERNAL SAW-TOOTH
- PARABOLA CORRECTION ADJUSTMENT
- KEYSTONE CORRECTION ADJUSTMENT
- LINE SIZE ADJUSTMENT
- LINE DYNAMIC CORRECTION POSSIBILITY (beam current)
- D CLASS OUTPUT MODULATOR WITH BUILD IN RECOVERY DIODE
- 50 OR 60Hz OPERATION
- LOW DISSIPATION
- FEW EXTERNAL COMPONENTS

DESCRIPTION

The TEA2031A is intended to ensure frame rate modulated parabolic and keystone corrections to the horizontal deflection circuitry of 110° color TV sets.

The linear frame saw-tooth is applied to appropriate circuitry from which a corresponding parabolic waveforms is obtained. This waveform is then fed to a comparator together with the linear line saw-tooth for comparison. Comparator's output drives the output power stage which is capable of sinking the external coil currents of up to 0.5A.

An internal recovery diode feeds back to the power supply the coil fly-back current pulses of as high as 0.5A.

Figure 1. Package

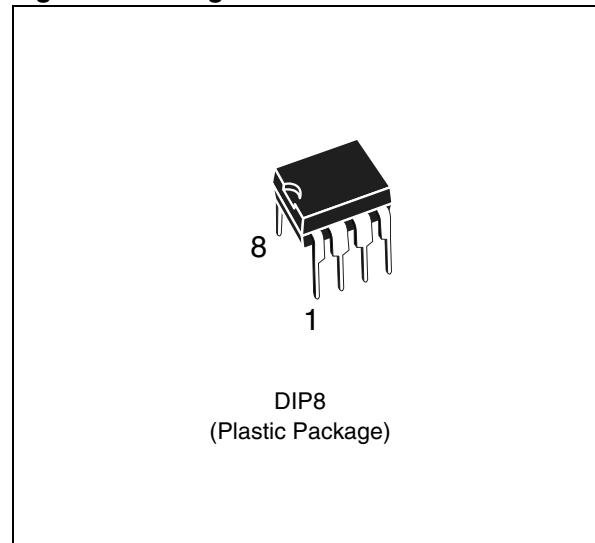

TEA2031A

Figure 2. Pin Connections

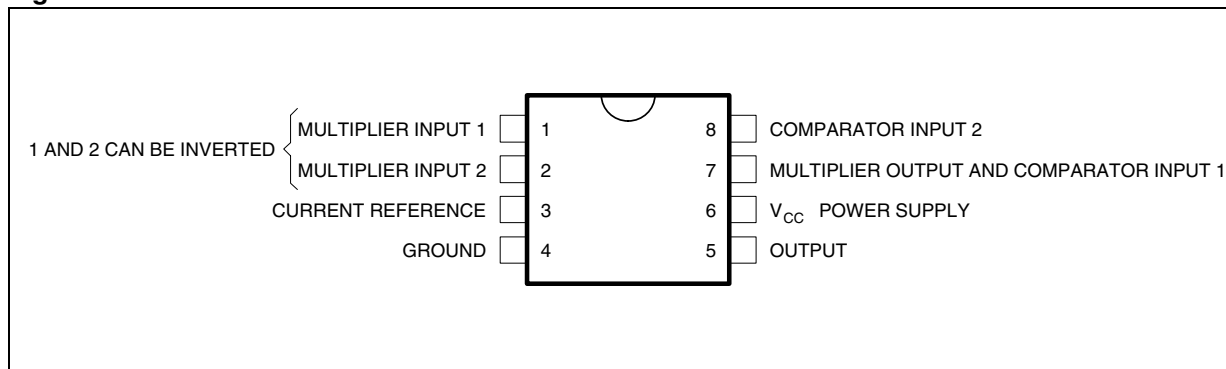
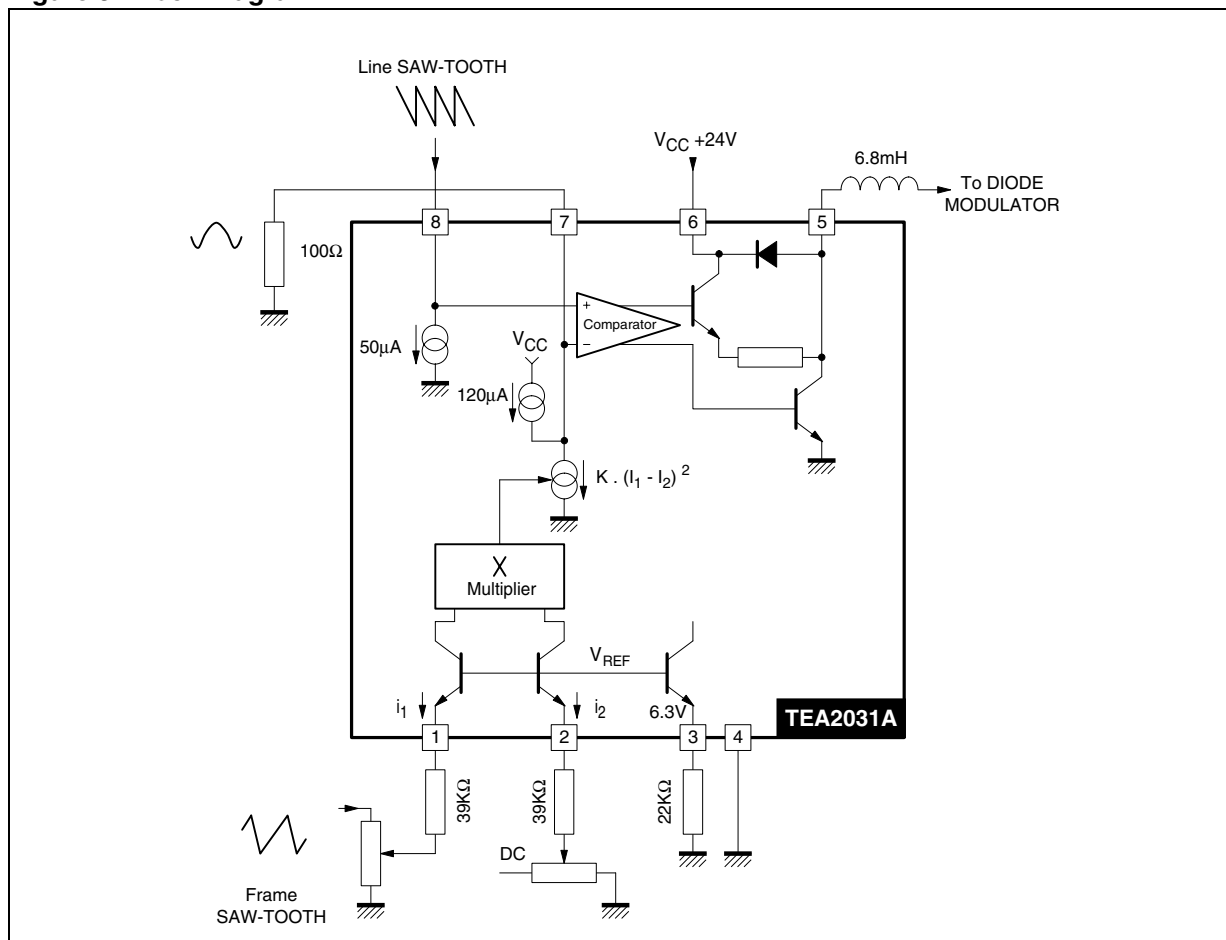

Figure 3. Block Diagram



GENERAL DESCRIPTION

The TEA2031A is intended to provide to 110° color TV sets a parabolic and keystone frame rate modulated correction in addition to the main horizontal scanning.

A stable 6.3V internal reference provides current and voltage references to the whole IC.

Pins 1 and 2 are two symmetrical inputs of an on-chip multiplier circuit and are internally held at 6.3V reference potential level. Current inputs to these pins are drawn from external sources via appropriate resistors. The frame saw-tooth waveform which has a peak-to-peak value of around 3 volts and a mean value of about 2.5 volts, supplies



the required current via a series resistor to pin 1. Likewise, the current to pin 2 is drawn through a series resistor from an external dc voltage source. These series resistors can have values of around 40k Ω resulting in input currents of approximately 0.1mA \pm modulation current.

Pin 7 should be loaded to ground through a 100k Ω resistor which as a result will produce a parabola of 5 volts peak-to-peak at pin 7. This parabola is symmetrical if the DC current flowing into pin 2 is equal to the mean input current of pin 1. Otherwise, the parabola becomes dissymmetrical and produces a keystone effect correction.

The line saw-tooth at pin 8 is obtained by feeding the line fly-back voltage through an integrator net-

work formed by a diode and a grounded capacitor (see typical application diagram). The DC component of the line saw-tooth is compensated by an internal current sinking source ; so that the mean DC values of line saw-tooth and frame parabola voltages are equal.

Line saw-tooth and frame parabola signals are applied to a comparator whose output is in the form of width modulated pulses. During every pulse duration, the output (pin 5) can sink external coil currents of up to 0.5A associated with diode modulator of the main horizontal scanning circuit.

An internal recovery diode feeds back the fly-back energy of the coil to the power supply. This diode can carry currents of up to 0.5A.

Table 1. Absolute Maximum Ratings

Symbol	Parameter	Value	Unit
V ₆₋₄	Supply Voltage	35	V
I ₅₋₄	Output Sink Current	0.5	A
I ₅₋₆	Diode Output Current	0.5	A
I ₁ and I ₂	Input Current	- 0.5	mA
P _{TOT}	Power Dissipation	0.8	W
T _{STG}	Storage Temperature Range	- 20 to 150	°C
I ₅₋₄	Non Repetitive Peak Current on Output Transistor	1.5	A
I ₅₋₆	Non Repetitive Peak Current on Output Diode	1.5	A

Table 2. Thermal Data

(T_{amb} = + 50°C)

Symbol	Parameter	Value	Unit
R _{th(j-a)}	Junction-ambient Thermal Resistance	80	°C/W

Table 3. ELECTRICAL OPERATING CHARACTERISTICS

Symbol	Parameter	Min.	Typ.	Max.	Unit
V ₆₋₄	Supply Voltage	16	24	35	V
I ₆	Supply Current (R ₍₃₋₄₎ = 22k Ω ; I _{OUT} = 0)		4	6	mA
	No Load Consumption (R ₍₃₋₄₎ = 22k Ω ; I _{OUT} = 0 ; V ₍₆₋₄₎ = 24V)		100	150	mW
V ₃₋₄	Voltage Reference (R ₍₃₋₄₎ = 22k Ω)	5.9	6.3	6.7	V
I _{1mean}	Frame Saw-tooth Input DC Mean Current R ₁ = 39k Ω at 2.5V Mean - saw-tooth Voltage		0.1		mA
I _{1PP}	Frame Saw-tooth Input Peak-to-peak Current R ₁ = 39k Ω at 2.5V Mean - saw-tooth Voltage		70		μ A
I ₂	Keystone Correction Input DC Current If I ₁ Mean = I ₂ : No Keystone Effect. R ₂ = 39k Ω at 2.5V DC ref.		0.1		mA
Δ I ₂	Keystone Correction Input DC Current for Maximum Keystone Effect		\pm 12.5		μ A

TEA2031A

V_{7H}	Top Parabola Voltage ($2V < V_1 = V_2 < 3V$)	10		15	V
ΔV_{7H}	Top parabola temperature drift			0.5	mV/°C

Table 4. SYMMETRICAL PARABOLA FOR NO KEYSTONE EFFECT
(see Figure 4)

Symbol	Parameter	Min.	Typ.	Max.	Unit
$V_{7H} - V_{7L}$	Parabola Amplitude ($V_2 = 2.5V$; V_1 mean = 2.5V, $V_{1pp} = 3V$)	3.5	5.2	6	V
$\Delta(V_{7H} - V_{7L})$	Parabola amplitude drift versus temperature			1	mV/°C
$\frac{V_{7H} - V_{7L1}}{V_{7H} - V_{7L2}}$	Symmetry	0.8	1	1.2	

Table 5. MAXIMUM DISSYMMETRICAL PARABOLA FOR MAXIMUM KEYSTONE EFFECT
(see Figure 4)

Symbol	Parameter	Min.	Typ.	Max.	Unit
$V_{7H} - V_{7B}$	Parabola Amplitude ($V_2 = 2V$ or $V_2 = 3V$; V_1 mean = 2.5V ; $V_{1pp} = 3V$)	5.3	8.5	9.2	V
$\frac{V_{7H} - V_{7B}}{V_{7H} - V_{7A}}$	Parabola Amplitude Ratio	0.8	1	1.2	

Table 6. DIFFERENTIAL AMPLIFIER

Symbol	Parameter	Min.	Typ.	Max.	Unit
	Input 8 Sink Current Source	0.04		0.06	mA
$\Delta I_8 = F(\theta)$	Input 8 Current Drift Versus Temperature			0.1	%/mW
	Transfer Characteristics (pins 7-8) ($F = 1\text{MHz}$)	5		500	μV
	Input Noise (pins 7-8)			50	V
	Rise and Fall Time (loutput = 250mA)	1			A/ μs
V_{5-4}	Output Saturation Voltage to Ground ($I_5 = 0.5\text{ A}$)			1.2	V
V_{6-5}	Output Saturation Voltage to V_{CC} ($I_5 = 0.1\text{A}$)			2	V
V_{5-6}	Output Diode Direct Voltage ($I_5 = + 0.5\text{A}$)			1.2	V

Figure 4. PARABOLA OUTPUT

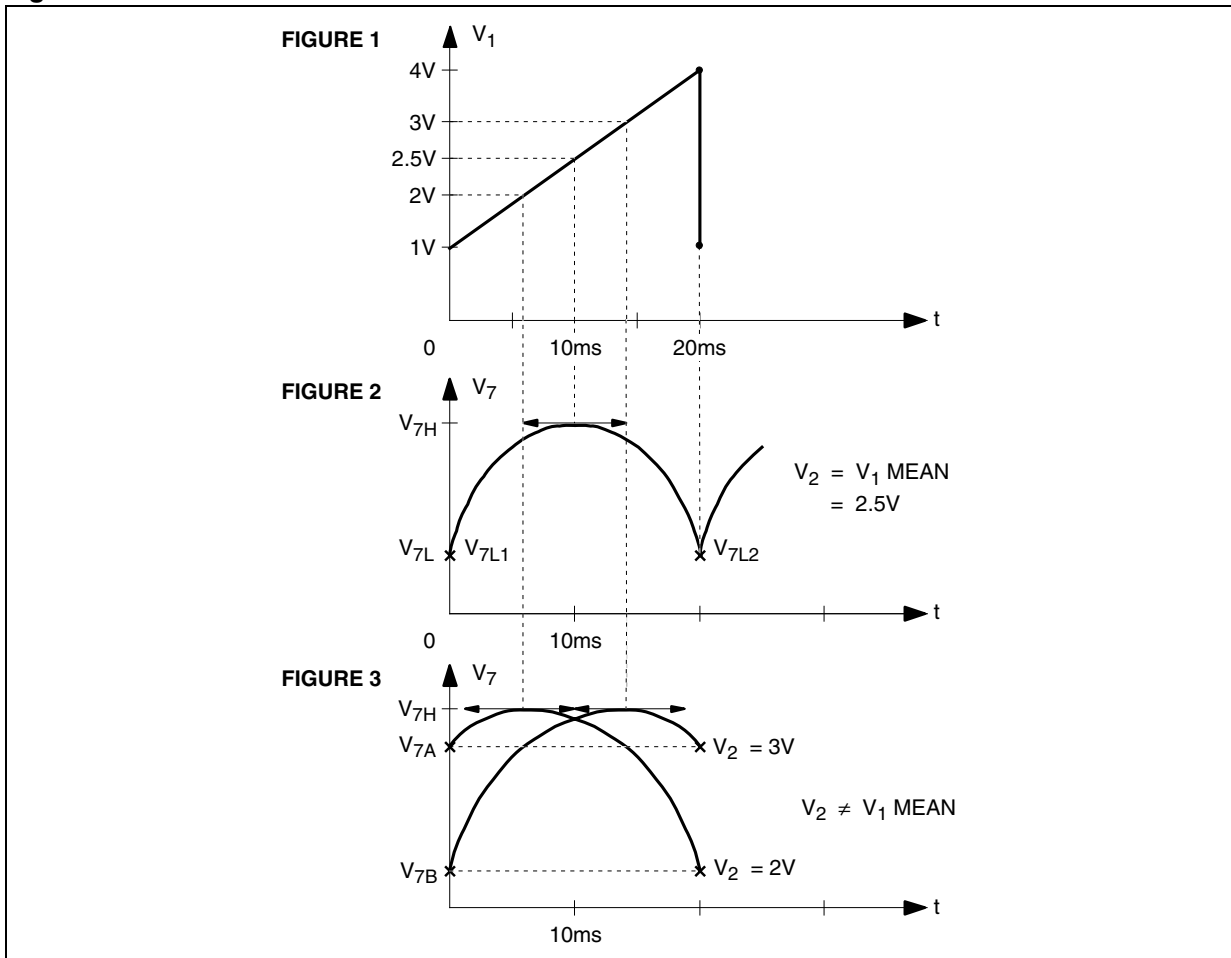

Figure 5. PARABOLA TEST DIAGRAM

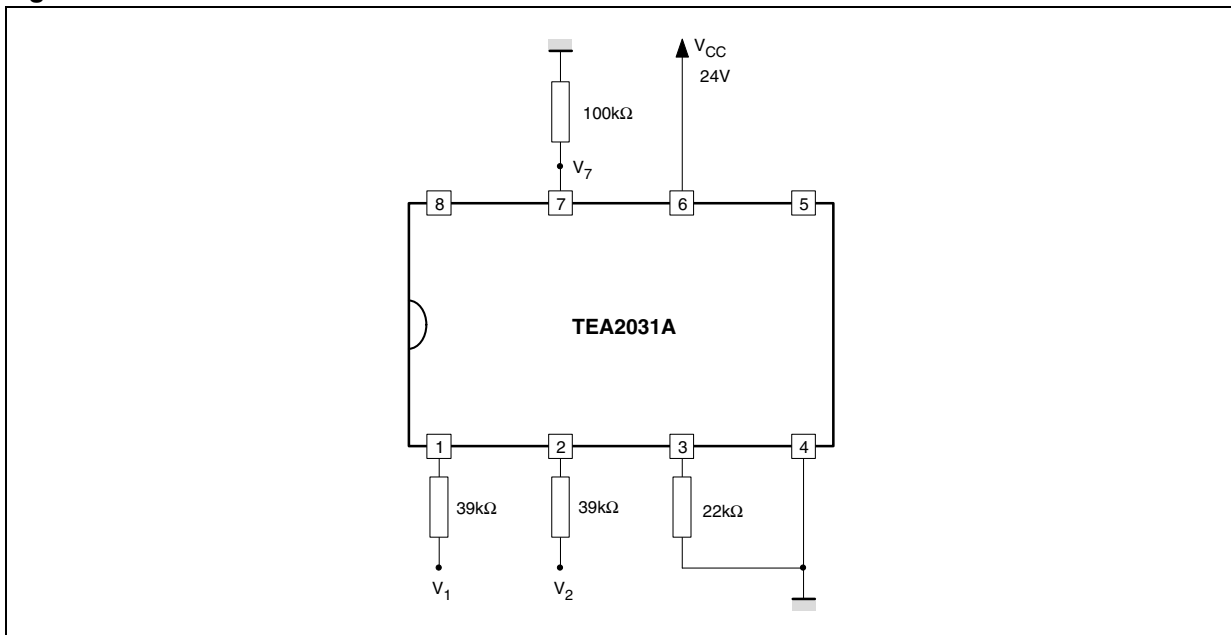
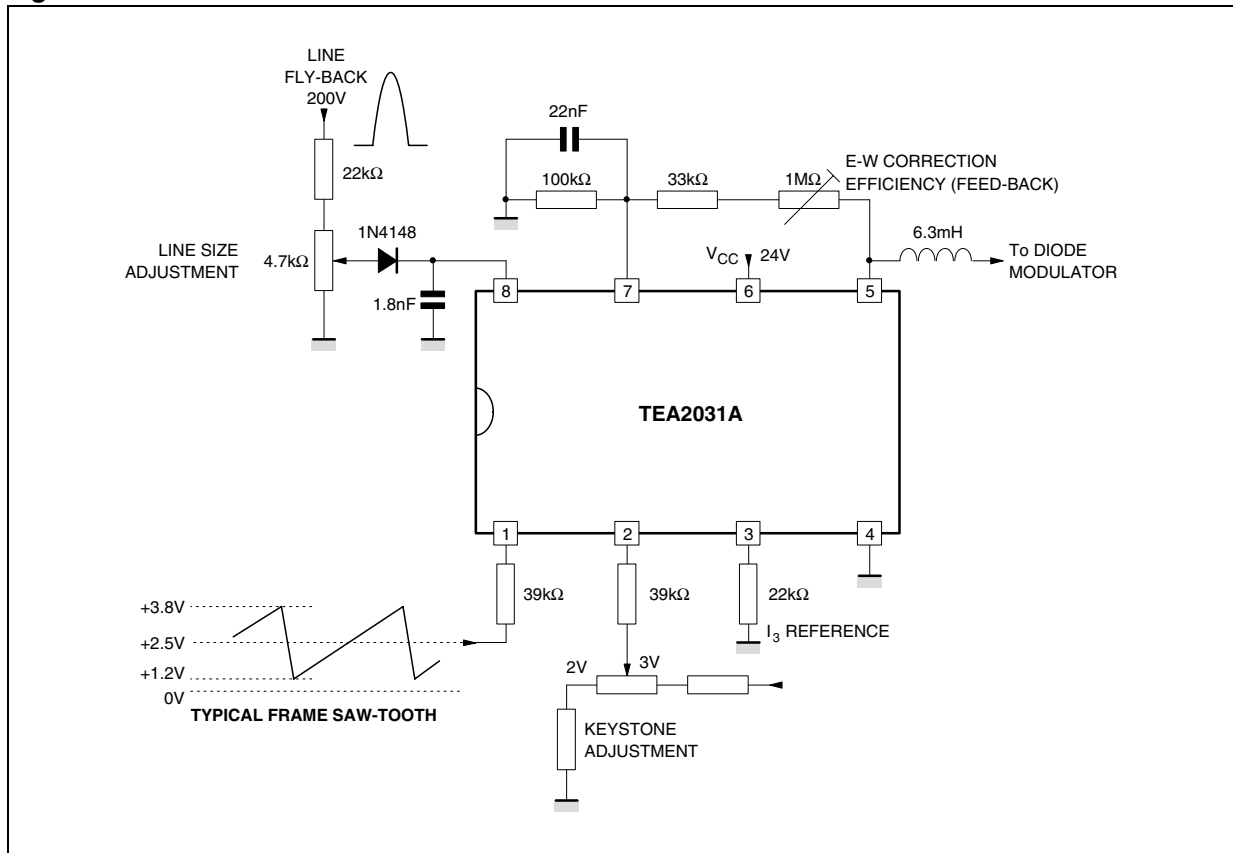

Figure 6. TYPICAL APPLICATION



TEA2031A

PART NUMBERING

Table 7. Order Codes

Part Number	Package	Temperature Range
TEA2031A	DIP8	-25 to 85 °C

PACKAGE MECHANICAL

Table 8. DIP8 - Mechanical Data

Symbol	millimeters			inches		
	Min	Typ	Max	Min	Typ	Max
A		3.32			0.131	
a1	0.51			0.020		
B	1.15		1.65	0.045		0.065
b	0.356		0.55	0.014		0.022
b1	0.204		0.304	0.008		0.012
D			10.92			0.430
E	7.95		9.75	0.313		0.384
e		2.54			0.100	
e3		7.62			0.300	
e4		7.62			0.300	
F			6.6			0.260
i			5.08			0.200
L	3.18		3.81	0.125		0.150
Z			1.52			0.060

Figure 7. DIP8 - Package Dimensions

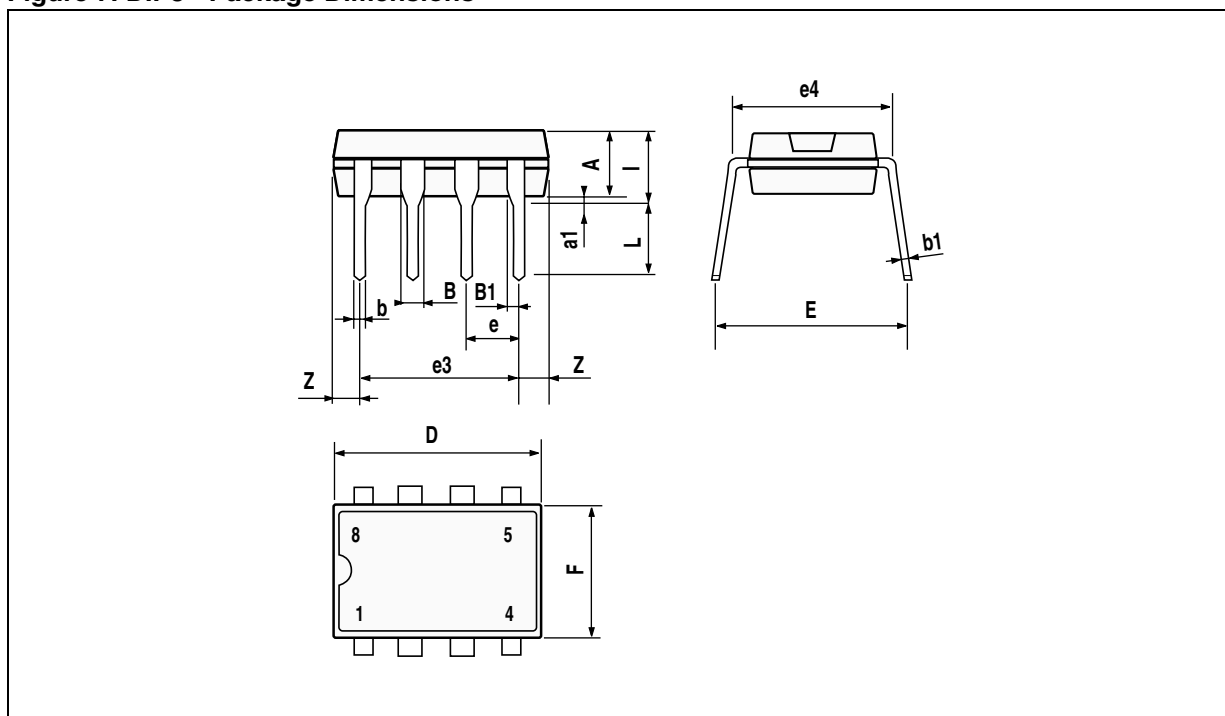

Note: Drawing is not to scale

REVISION HISTORY

Table 9. Revision History

Date	Revision	Description of Changes
May-1993	1	First Issue
20-Apr-2004	2	Stylesheet update. No content change.

Information furnished is believed to be accurate and reliable. However, STMicroelectronics assumes no responsibility for the consequences of use of such information nor for any infringement of patents or other rights of third parties which may result from its use. No license is granted by implication or otherwise under any patent or patent rights of STMicroelectronics. Specifications mentioned in this publication are subject to change without notice. This publication supersedes and replaces all information previously supplied. STMicroelectronics products are not authorized for use as critical components in life support devices or systems without express written approval of STMicroelectronics.

The ST logo is a registered trademark of STMicroelectronics.
All other names are the property of their respective owners

© 2004 STMicroelectronics - All rights reserved

STMicroelectronics GROUP OF COMPANIES

Australia - Belgium - Brazil - Canada - China - Czech Republic - Finland - France - Germany - Hong Kong - India - Israel - Italy - Japan -
Malaysia - Malta - Morocco - Singapore - Spain - Sweden - Switzerland - United Kingdom - United States

www.st.com

