

**0.5A INTELLIGENT POWER SWITCH**

- HIGH OUTPUT CURRENT 500mA
- SHORT-CIRCUIT PROTECTION UP TO  $V_{CC} = +35V$
- INTERNAL THERMAL PROTECTION WITH EXTERNAL RESET AND SYNCHRONIZATION CAPABILITY
- OPEN GROUND PROTECTION
- OUTPUT VOLTAGE CAN BE LOWER THAN GROUND FOR FAST INDUCTIVE LOAD DEMAGNETIZATION
- DIFFERENTIAL INPUTS FOR ANY LOGIC SYSTEM COMPATIBILITY
- INPUT VOLTAGE CAN BE HIGHER THAN  $V_{CC}$
- LARGE SUPPLY VOLTAGE RANGE FROM 6V TO 35V
- SINK AND SOURCE ALARM OUTPUTS
- NO NEED FOR EXTERNAL CLAMPING DIODE FOR DEMAGNETIZATION ENERGY UP TO 150mJ
- SEVERAL DEVICES CAN BE CONNECTED IN PARALLEL

**DESCRIPTION**

The TDE1798 is an interface circuit delivering high currents and capable of driving any type of loads.

The output is protected from short-circuits with the positive supply or ground. In addition thermal shut down is provided to keep the IC from overheating. If internal dissipation becomes too high,

**PIN CONNECTION (Top view)**

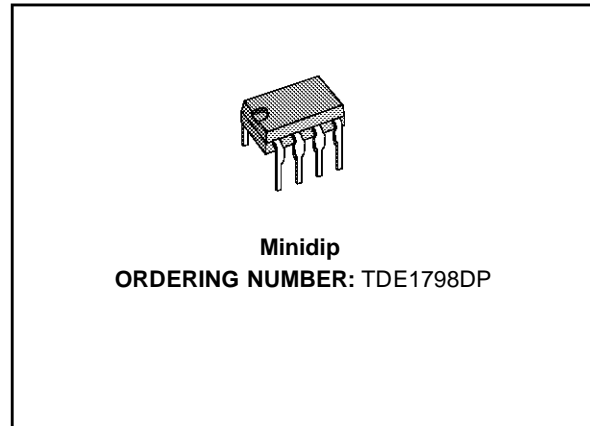
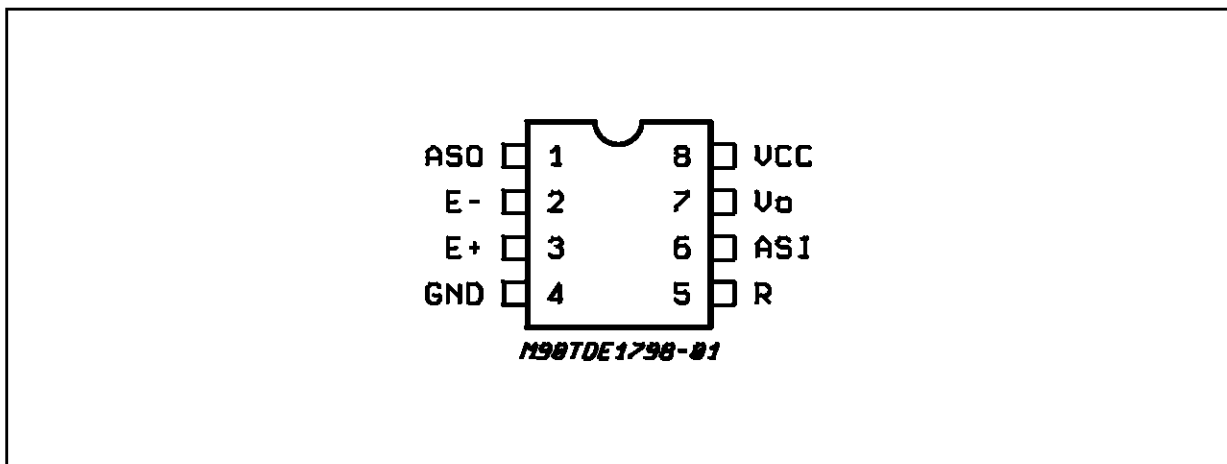

the driver will shut down to prevent excessive heating. The output stays null after the overload is off, if the reset input is low. If high, the output will alternatively switch on and off until the overload is removed.

Higher current can be obtained by paralleling the outputs of several devices. In this case, the devices can be reactivated simultaneously after an overload if their reset input are connected in parallel.

The device operates over a wide range of supply voltages from standard  $\pm 15$  operational amplifier supplies to the single  $\pm 6V$  or  $+35V$  used for industrial electronic systems. Input voltage can be higher than the  $V_{CC}$ . The output is low in open ground conditions.

**ABSOLUTE MAXIMUM RATINGS**

Symbol	Parameter	Test Conditions	Unit
$V_{CC}$	Supply Voltage	50	V
$V_{ID}$	Input Differential Voltage	50	V
$V_I$	Input Voltage	-30 to +50	V
$V_{I(reset)}$	Reset Input Voltage	$V_{CC} - 50$ to $V_{CC}$	V
$I_O$	Output Current	internally limited	A
$P_{tot}$	Power Dissipation	Internally Limited	mW
	Reset Input Sink Current (in thermal shut-down)	15	mA
$W_D$	Repetitive Maximum Demagnetization Energy - $10^6$ Operations	150	mJ
$T_{op}$	Operating Ambient Temperature Range	-25 to +85	°C
$T_{stg}$	Storage Temperature Range	-65 to +150	°C
$I_{A(sink)}$	Alarm Output Sink Current	25	mA
$I_{A(source)}$	Alarm Output Source Current	12	mA

**BLOCK DIAGRAM**

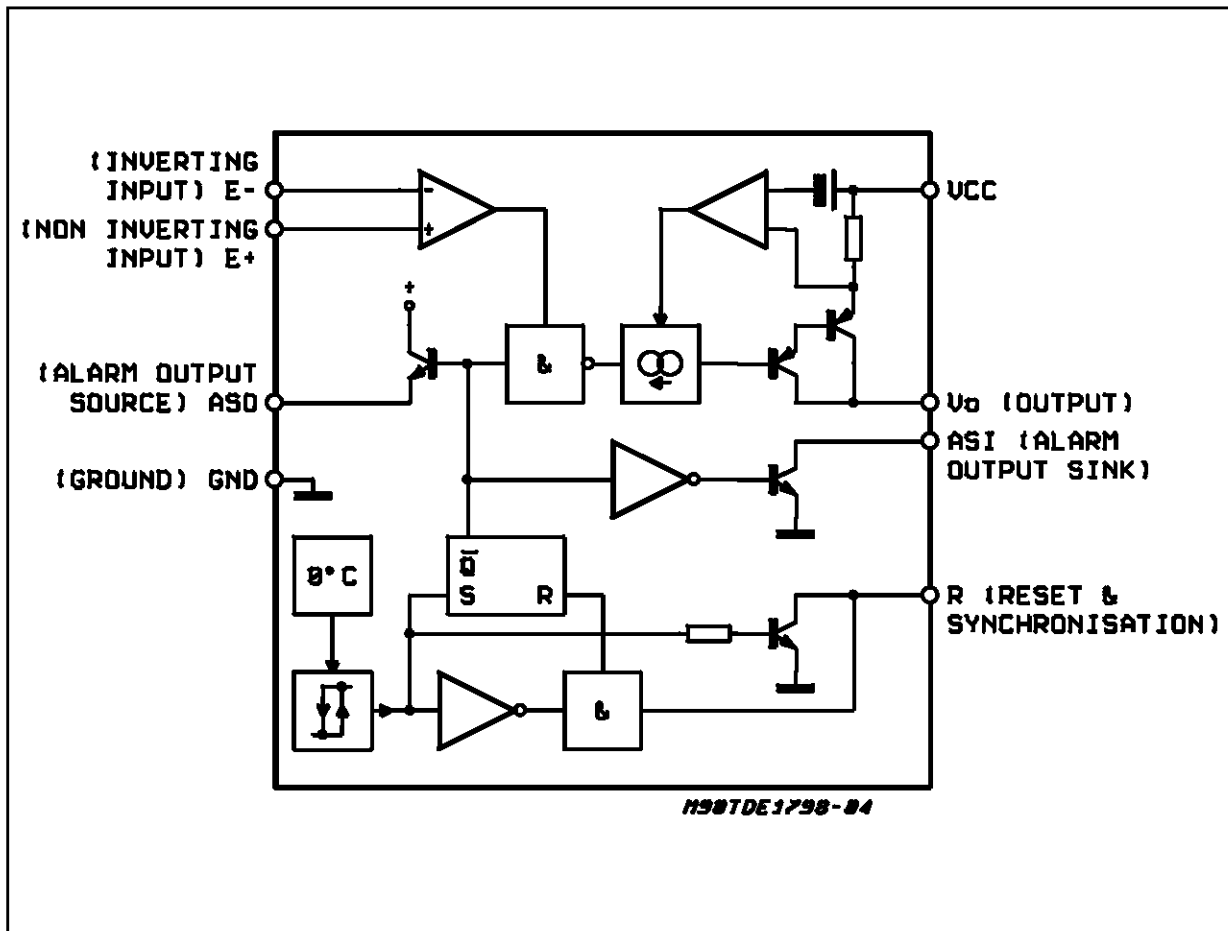

## THERMAL DATA

Symbol	Description	Value	Unit
$R_{th\ j-case}$	Thermal Resistance Junction-case (1)	max.	30
$R_{th\ j-ambient}$	Thermal Resistance Junction-ambient (1)	max.	90

1) Devices bounded on a 40cm<sup>2</sup> glass-epoxy printed circuit 0.15cm thick with 4cm<sup>2</sup> of copper

## ELECTRICAL CHARACTERISTICS (note 2)

TDE -25°C ≤ T<sub>j</sub> ≤ +85°C, 6V ≤ V<sub>CC</sub> ≤ +35V, I<sub>o</sub> ≤ 500mA (unless otherwise specified).

Symbol	Parameter	Test Condition	Min.	Typ.	Max.	Unit
V <sub>IO</sub>	Input Offset Voltage	(note 3)	–	2	50	mV
I <sub>CC</sub>	Power Supply Current	Output High (T <sub>amb</sub> = +25°C, I <sub>o</sub> = 500mA) Output Low	– –	6.5 2	8 4	mA mA
I <sub>IB</sub>	Input Bias Current		–	15	40	μA
V <sub>ICR</sub>	Common-mode Input Voltage Range	(note 4)	1	–	45	V
V <sub>I</sub>	Input Voltage Range	V <sub>ref</sub> > +1V, (note 4 and 5)	-25	–	45	V
I <sub>SC</sub>	Short-circuit Output Current	V <sub>CC</sub> = 30V, t = 10ms	0.7	0.9	1.3	A
V <sub>CC</sub> - V <sub>O</sub>	Output Saturation Voltage	I <sub>o</sub> = 500mA ( V <sup>+</sup> I - V <sup>-</sup> I  > 50mV)	–	1	1.25	V
I <sub>OL</sub>	Output Low Leakage Current	T <sub>j</sub> = +85°C (V <sub>CC</sub> = 30V, V <sub>O</sub> = 0V)	–	10	100	μA
I <sub>(pin 1) source</sub> I <sub>(pin 6) sink</sub>	Available Alarm Output Current	Source (V <sub>(pin 1)</sub> = V <sub>CC</sub> - 2.5V) Sink (in thermal shut-down) V <sub>(pin 6)</sub> = 2V	4 6	8 15	– –	mA mA
I <sub>RH</sub> I <sub>RL</sub>	Reset Input Current		– -1	15 0	40 +1	μA μA
V <sub>th</sub>	Reset Threshold		0.8	1.4	2	V
I <sub>reset</sub>	Reset Output Sink Current	(in thermal shut-down) for V <sub>reset</sub> ≤ +0.8V	2	–	–	mA
I <sub>OL(open GND)</sub>	Output Leakage Current	(open ground)	–	10	100	μA
V <sub>BRVEO</sub>	Output Transistor Avalanche Volt.	V <sub>CC</sub> - V <sub>O</sub>	65	–	110	V

## Notes:

- 2) For operating at high temperature, the TDE1798 must be derated based on a 150°C maximum junction temperature and the junction-ambient thermal resistance.
- 3) The offset voltage given is the maximum value of input differential voltage required to drive the output voltage within 2V of the ground or the supply voltage;
- 4) Input voltage range is independent of the supply voltage;
- 5) The reference input can be the inverting or the non-inverting one.

POWER SUPPLY CURRENT.

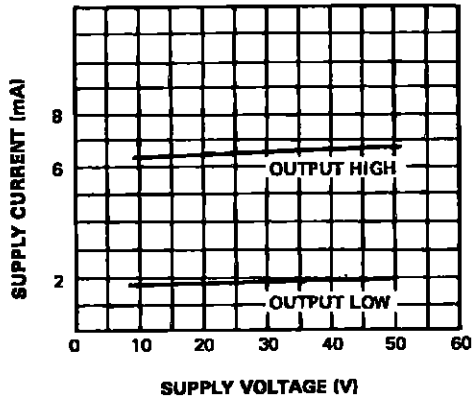

OUTPUT SATURATION VOLTAGE.

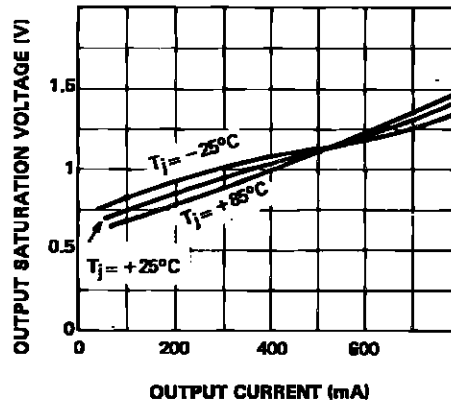

ALARM OUTPUT CURRENT SINK  
(after thermal shut down).

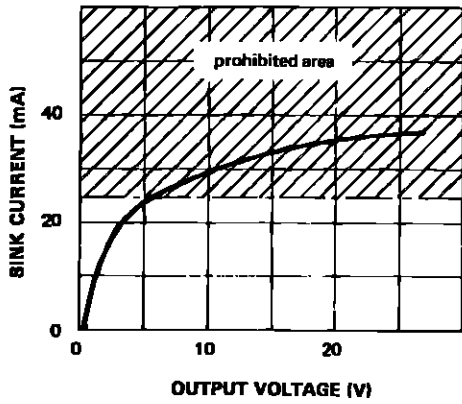

ALARM OUTPUT CURRENT SOURCE  
(normal operation).

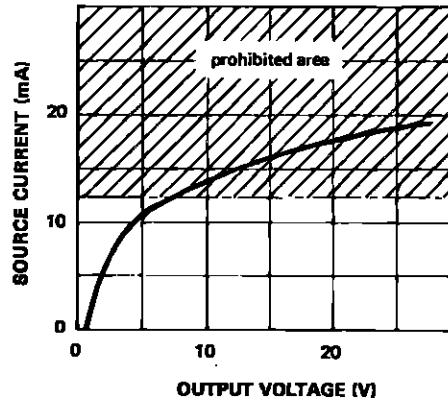

RESPONSE TIME.

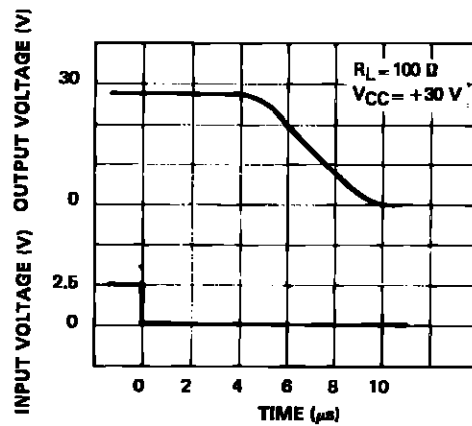
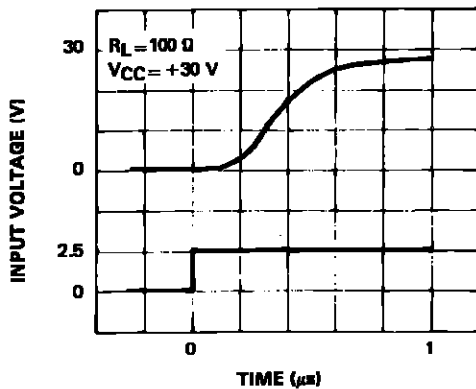

TYPICAL APPLICATION AUTOMATIC RESET

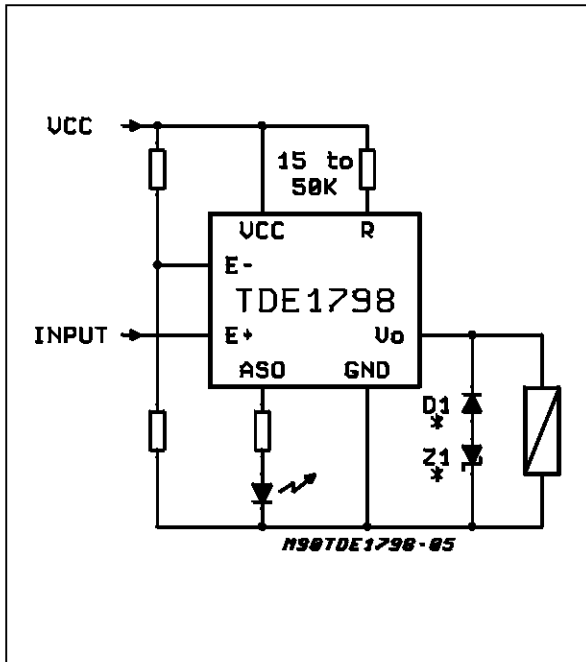

TYPICAL APPLICATION CONTROLLED RESET

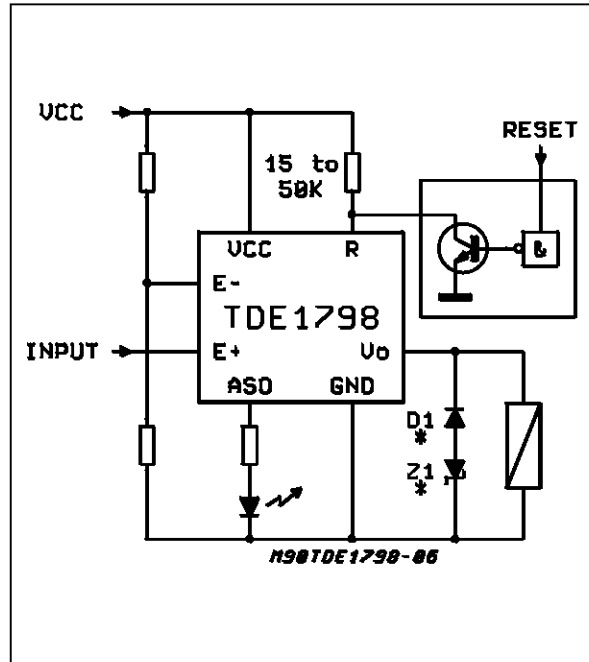

(\*) D1 and Z1 needed if the demagnetization energy is higher than 150mJ

SHORT CIRCUIT CONDITIONS WITH AUTOMATIC RESET

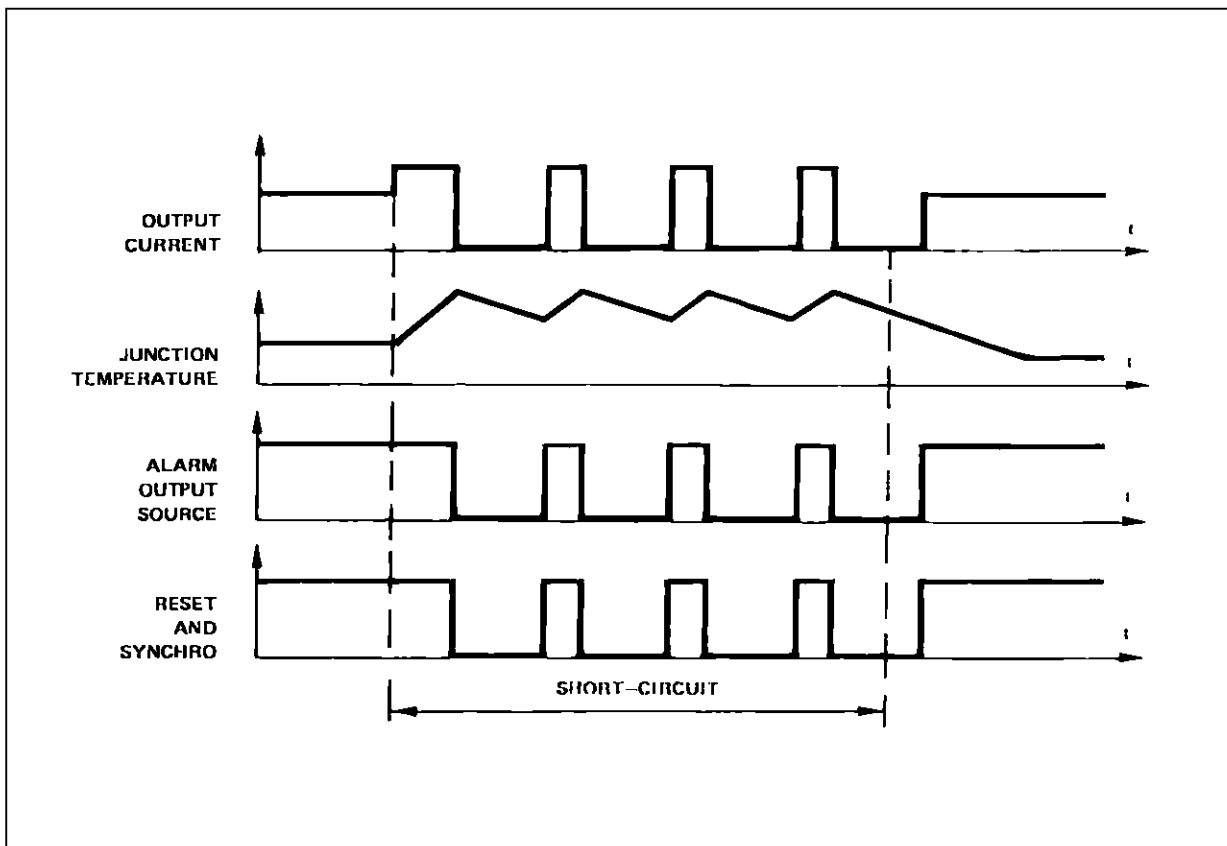

SHORT CIRCUIT CONDITIONS WITH CONTROLLED RESET

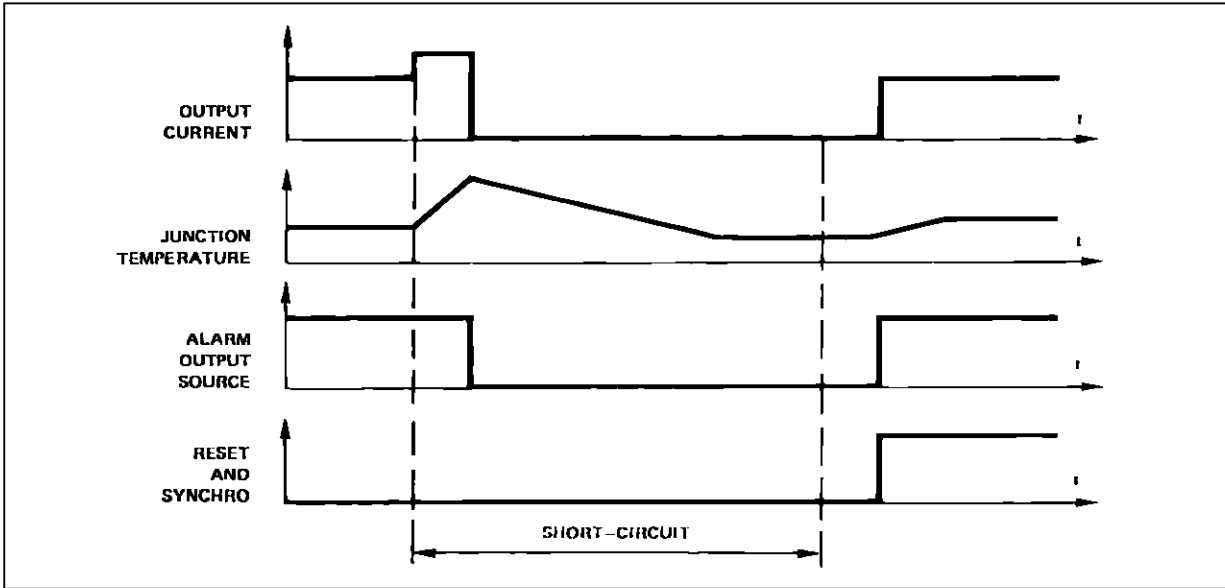

DEMAGNETIZATION OF INDUCTIVE LOADS WITHOUT EXTERNAL CLAMPING DEVICES.

With no external clamping device, the energy of demagnetization is dissipated in the TDE1798 output stage, and the clamping voltage is the col-

lector-emitter breakdown voltage  $V_{(BR)CEO}$ .

This method provides a very fast demagnetization of inductive loads and can be used up to 150 mJ.

The amount of energy  $W$  dissipated in the output stage during a demagnetization is :

$$W = V_{(BR)} \frac{L}{R} \left[ I_o - \frac{V_{(BR)} - V_{CC}}{R} \text{Log} \left( 1 + \frac{V_{CC}}{V_{(BR)} - V_{CC}} \right) \right]$$

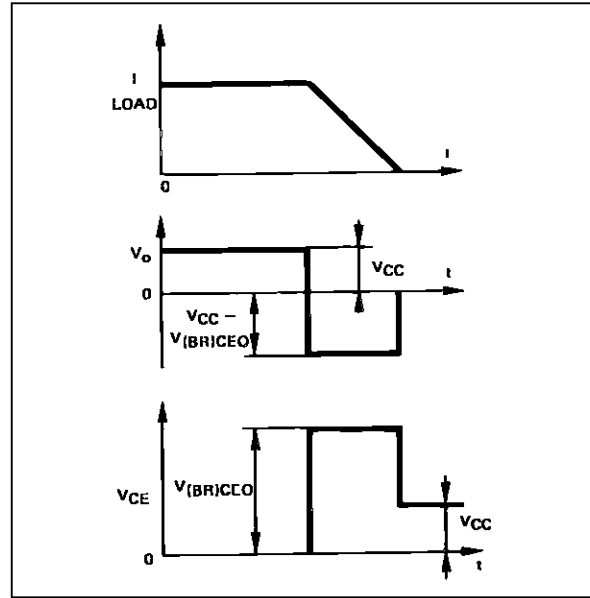
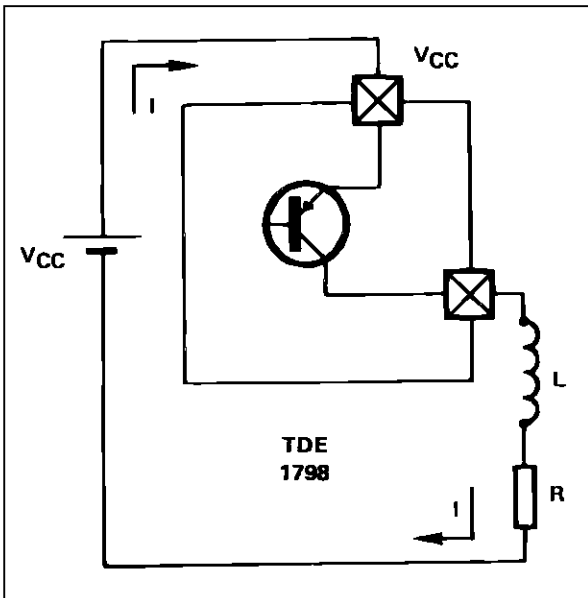

**Remark 1 :** This energy is dissipated inside the case, then must be included in the whole power dissipation.

**Remark 2 :** The use of external clamping device is recommended in case of parallel driving of

loads. The dispersion of the collector-emitter breakdown voltage  $V_{(BR)}$  would induce the circuit with the lowest  $V_{(BR)}$  to dissipate the whole demagnetization energy (which is roughly proportional to  $I_o^2$ ).

A 1 AMP. DRIVER (reset may be either automatic or controlled)

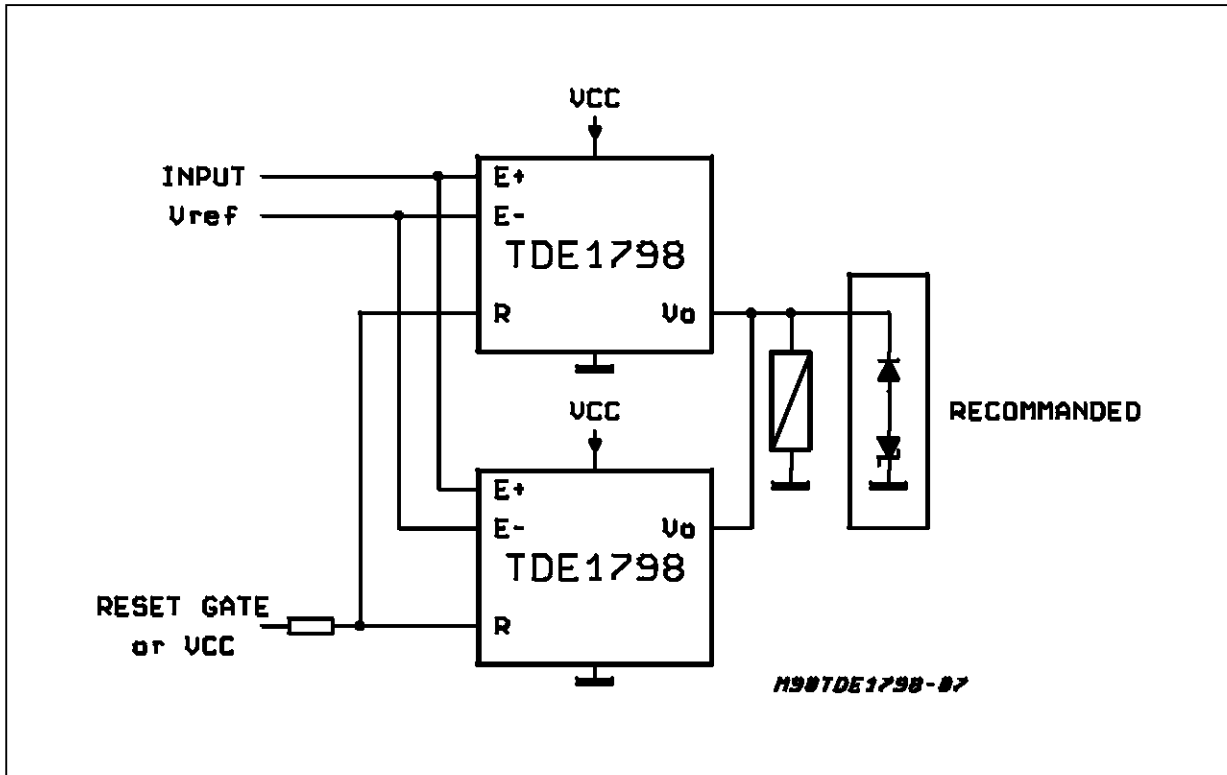

ALARM OUTPUT SINK

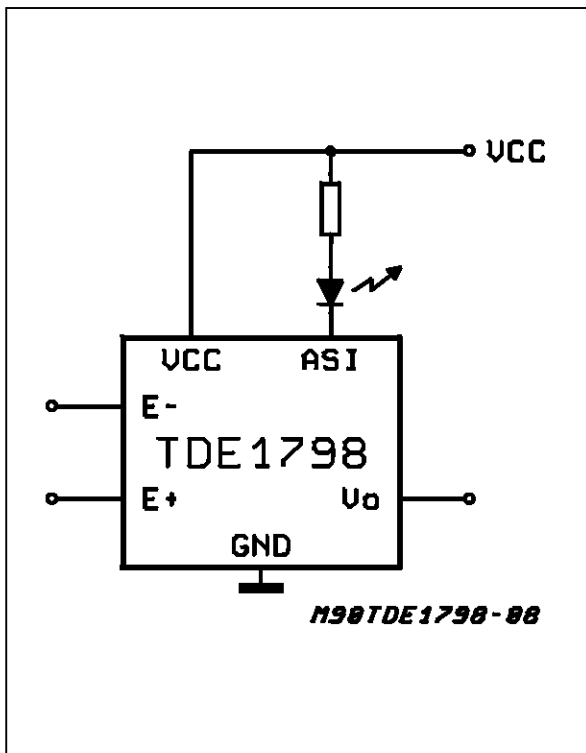

ALARM OUTPUT SOURCE

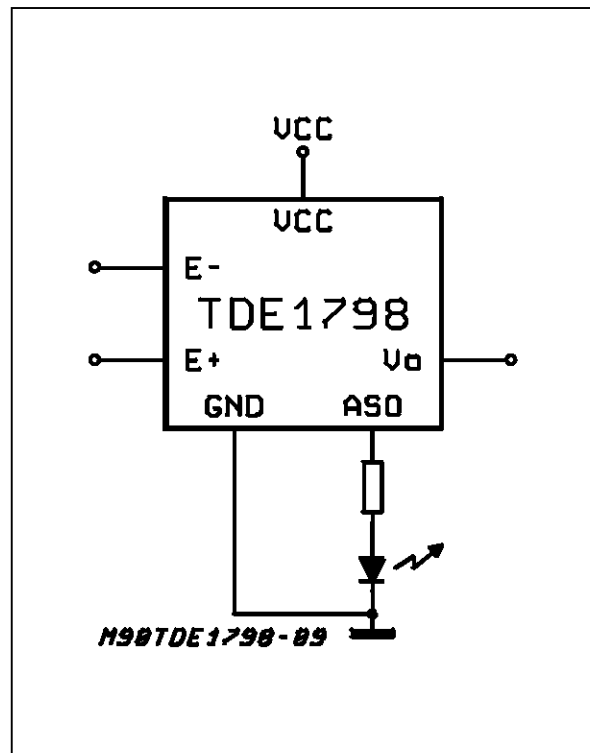

# TDE1798

## PARALLEL ALARM OUTPUTS

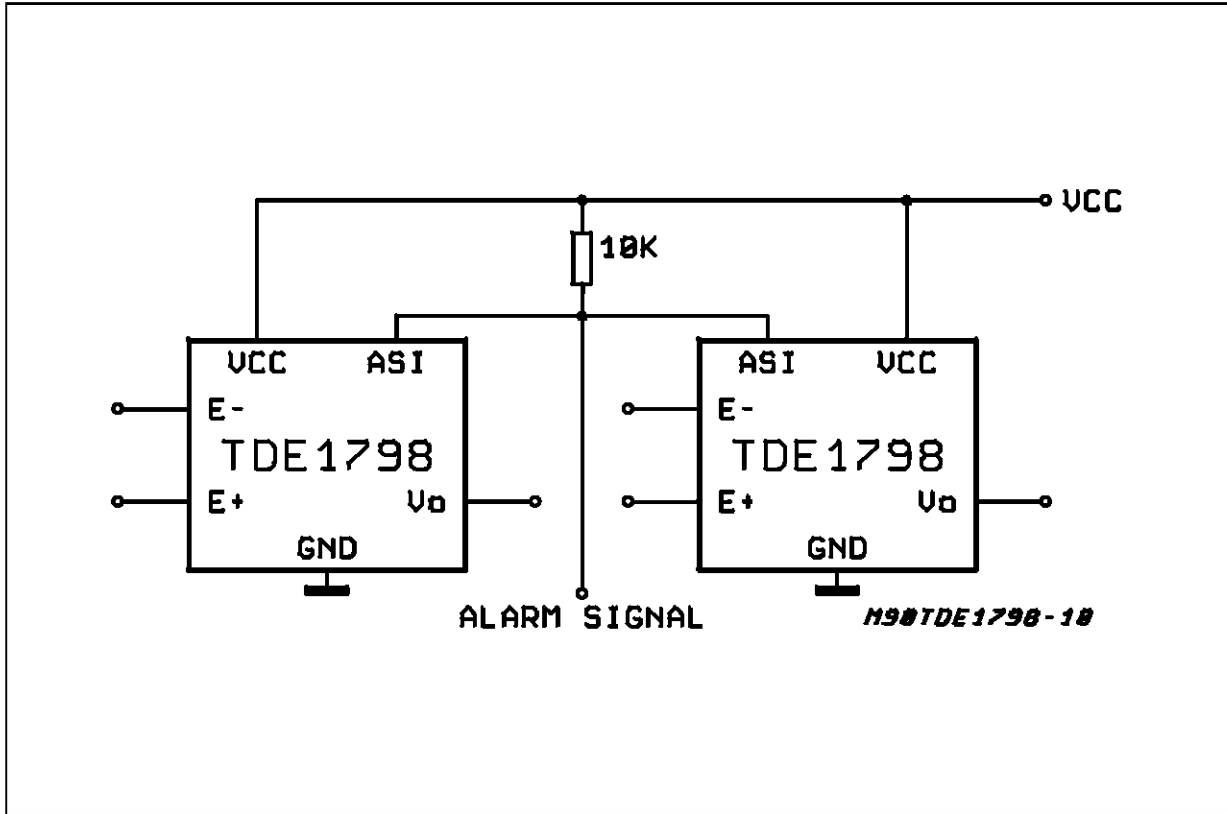

## INTERFACE BETWEEN HIGH VOLTAGE AND LOW VOLTAGE SYSTEM

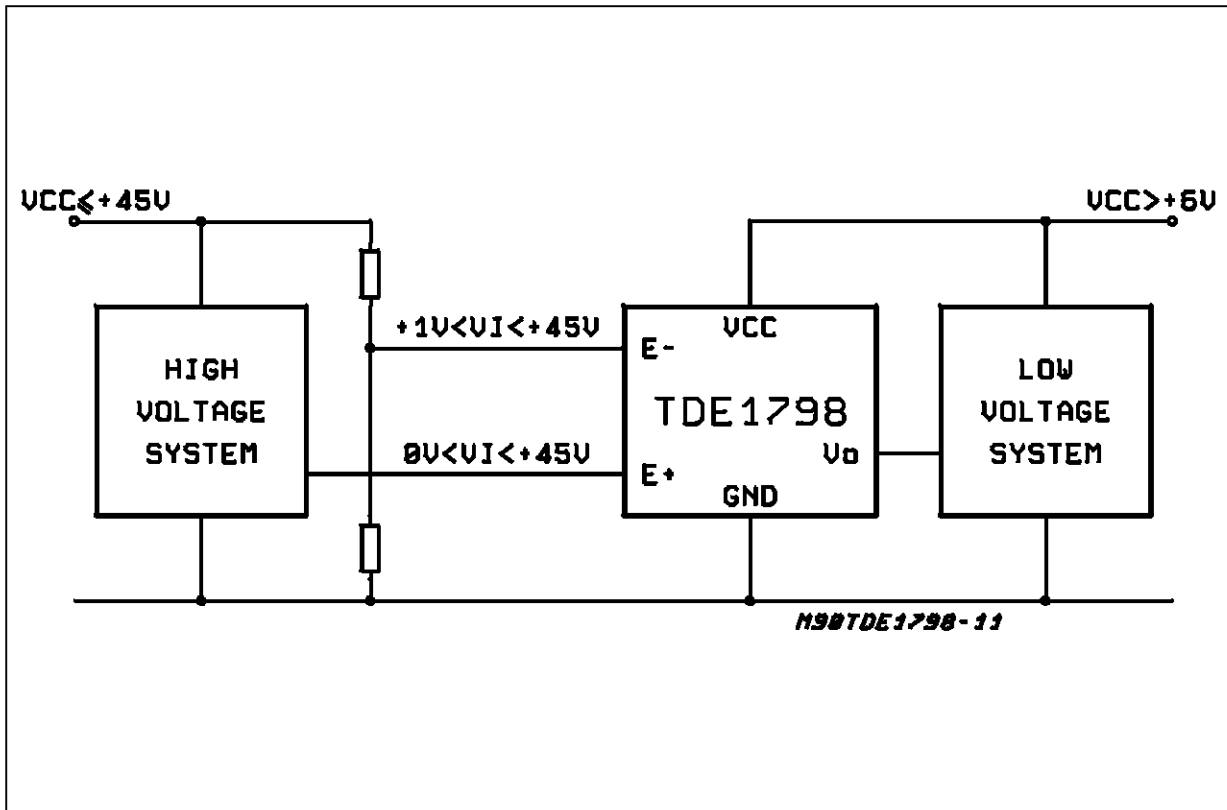



RESET AND SYNCHRONIZATION

Recommended diagram when the outputs are in parallel. After thermal disjunction a restart is possible when all the circuits are returned in operating conditions.

sible when all the circuits are returned in operating conditions.

SYNCHRONOUS AUTOMATIC RESET (parallel or independent outputs)

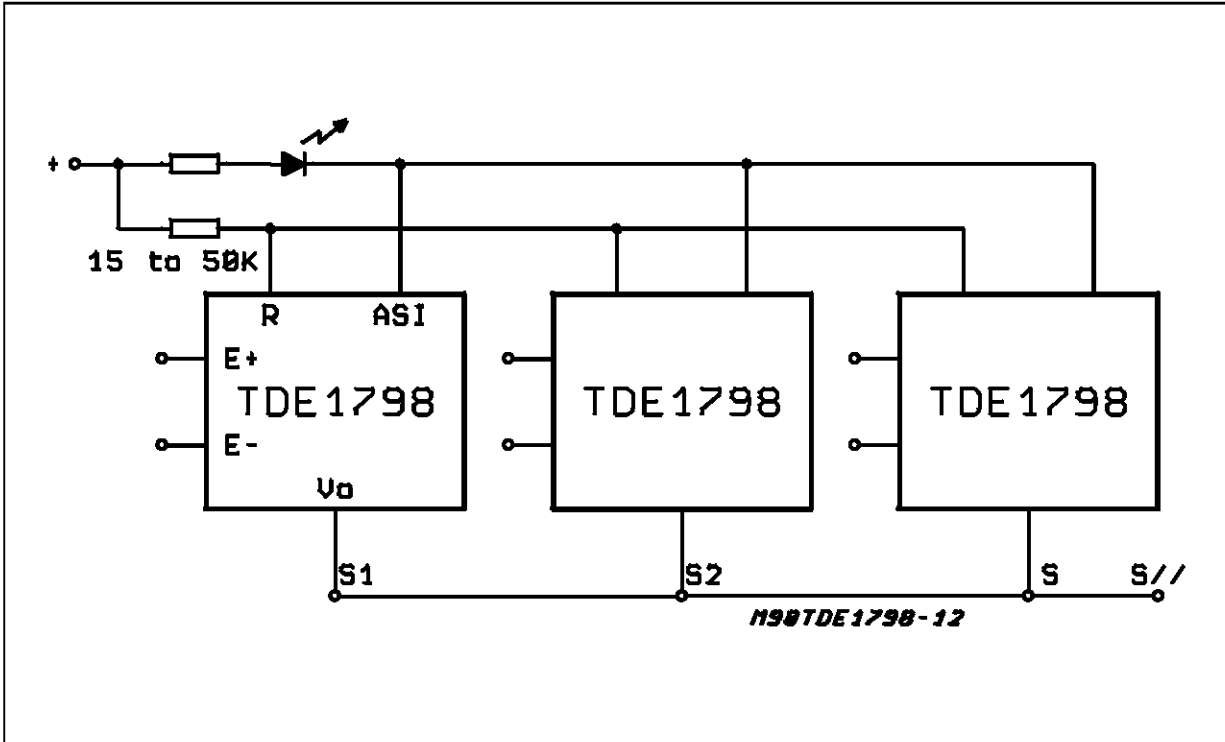

SYNCHRONOUS CONTROLLED RESET (parallel or independent outputs)

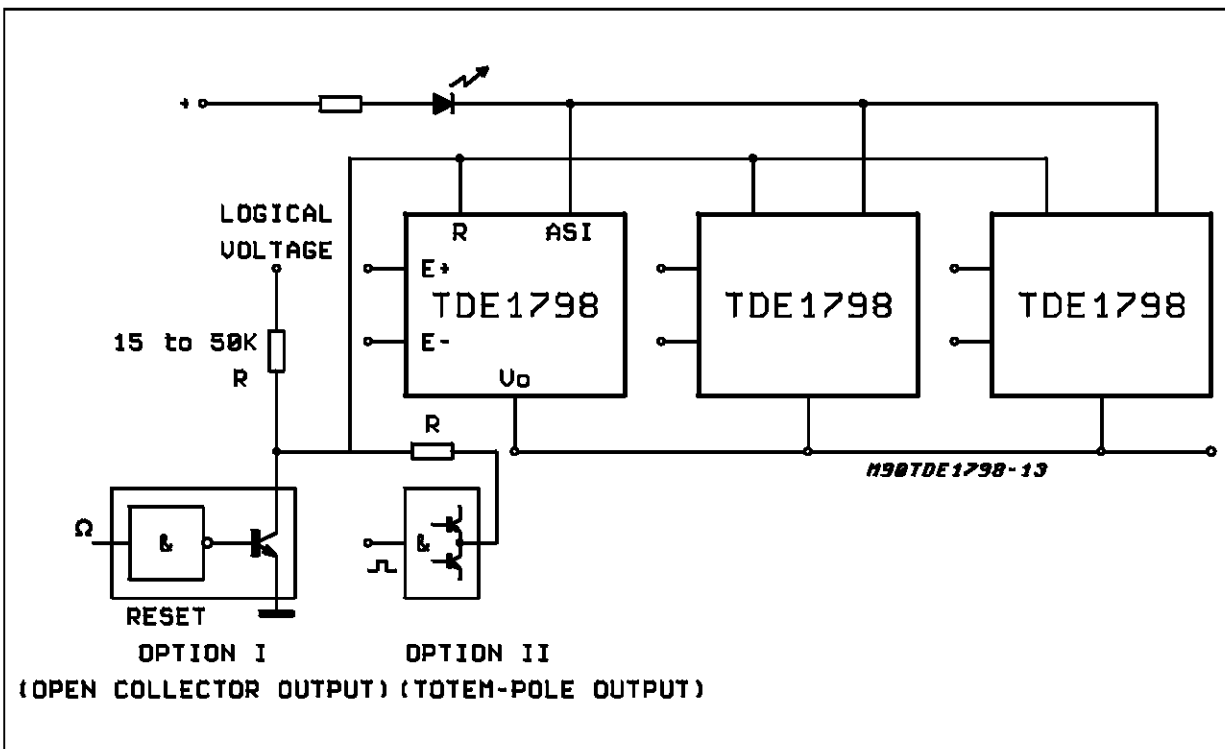

# TDE1798

## TWO QUADRANTS D.C. MOTOR DRIVE

### MAIN FEATURES

- $V_{cc} - V_{cc} \leq 50V$
- Maximum output current 0.5A
- Full protection against overloads and short-circuits
- No need of deadtime during rotation reversing
- TTL compatible inputs
- TDE1799 and TDE1798 input signals have the same reference

- No automatic restart after disjunction

CW/CCW	ON PFF	1798	1799
0	0	OFF	OFF
0	1	ON	OFF
1	1	OFF	ON
1	0	OFF	OFF

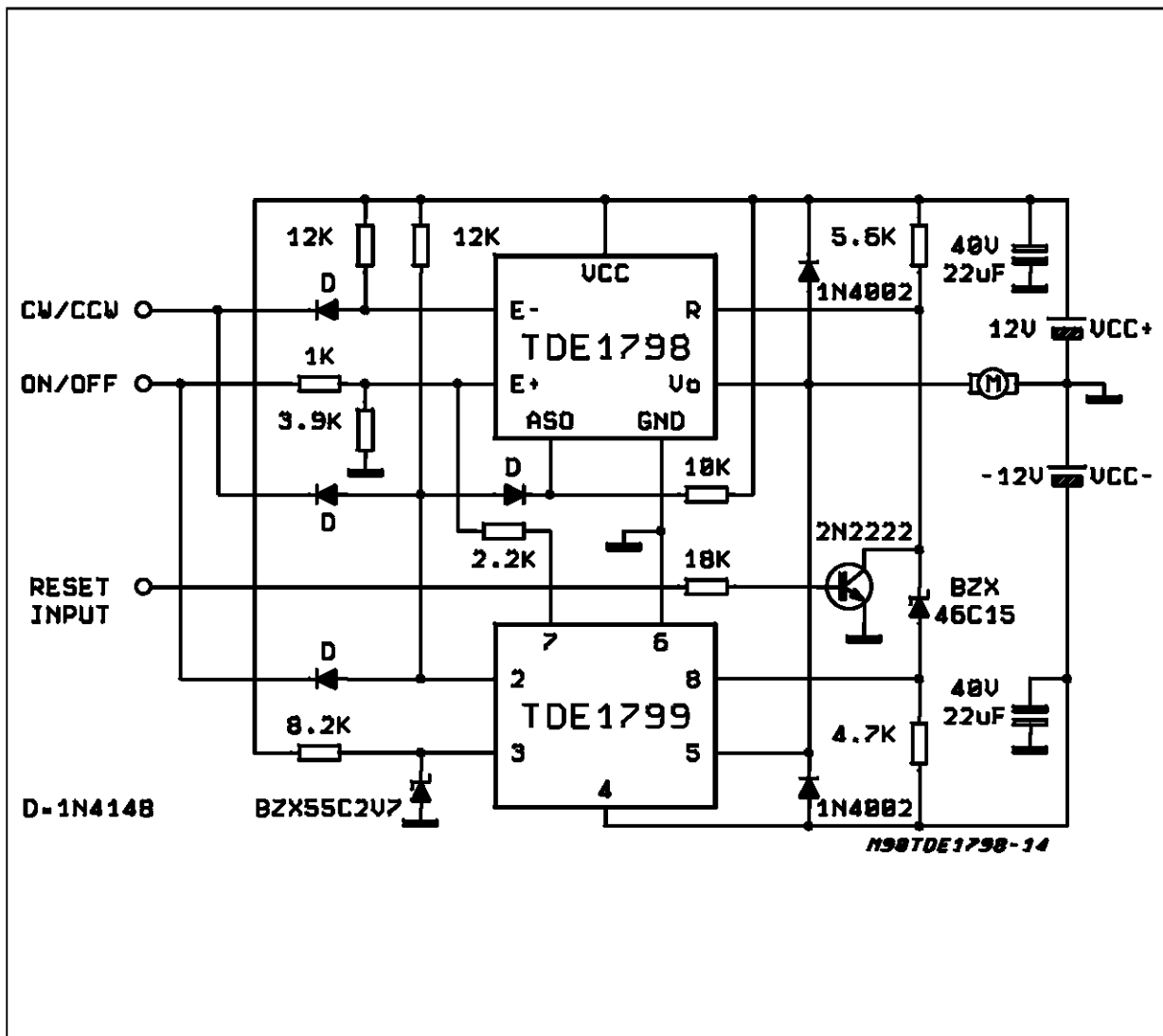

ON/OFF CYCLES

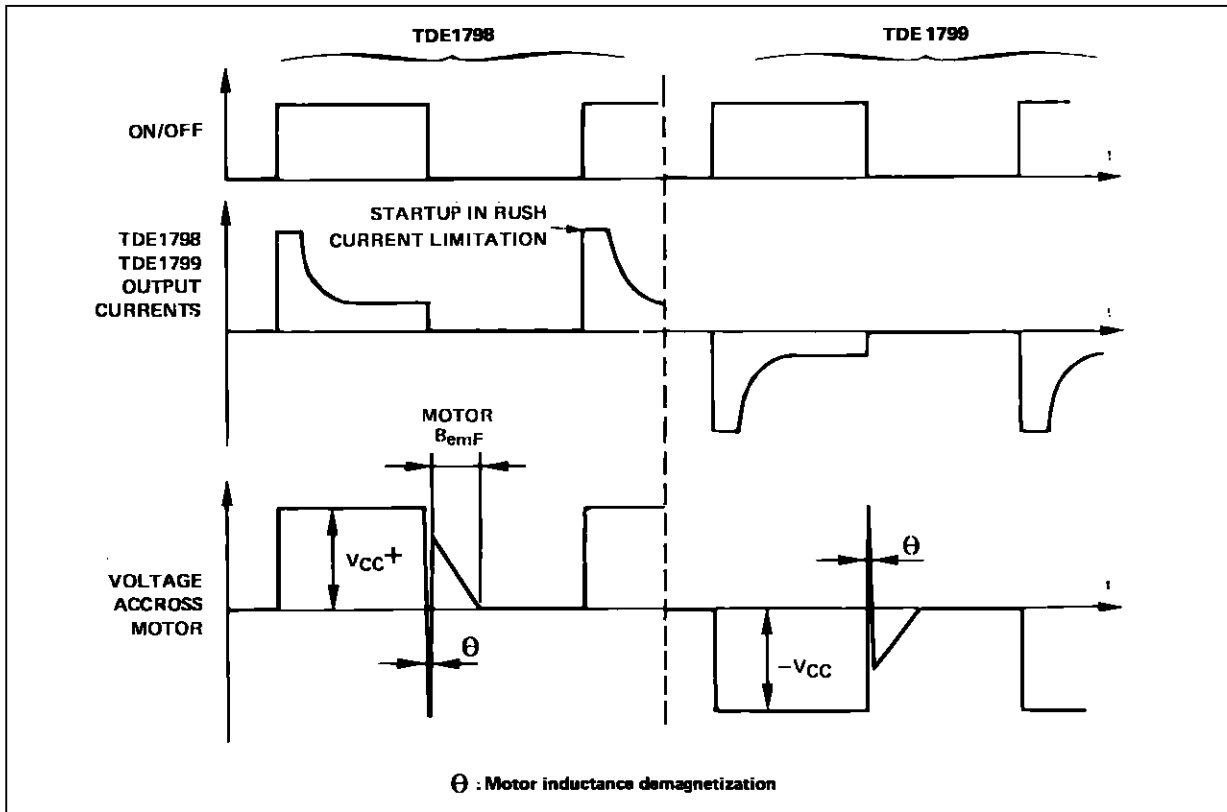

ROTATION REVERSING

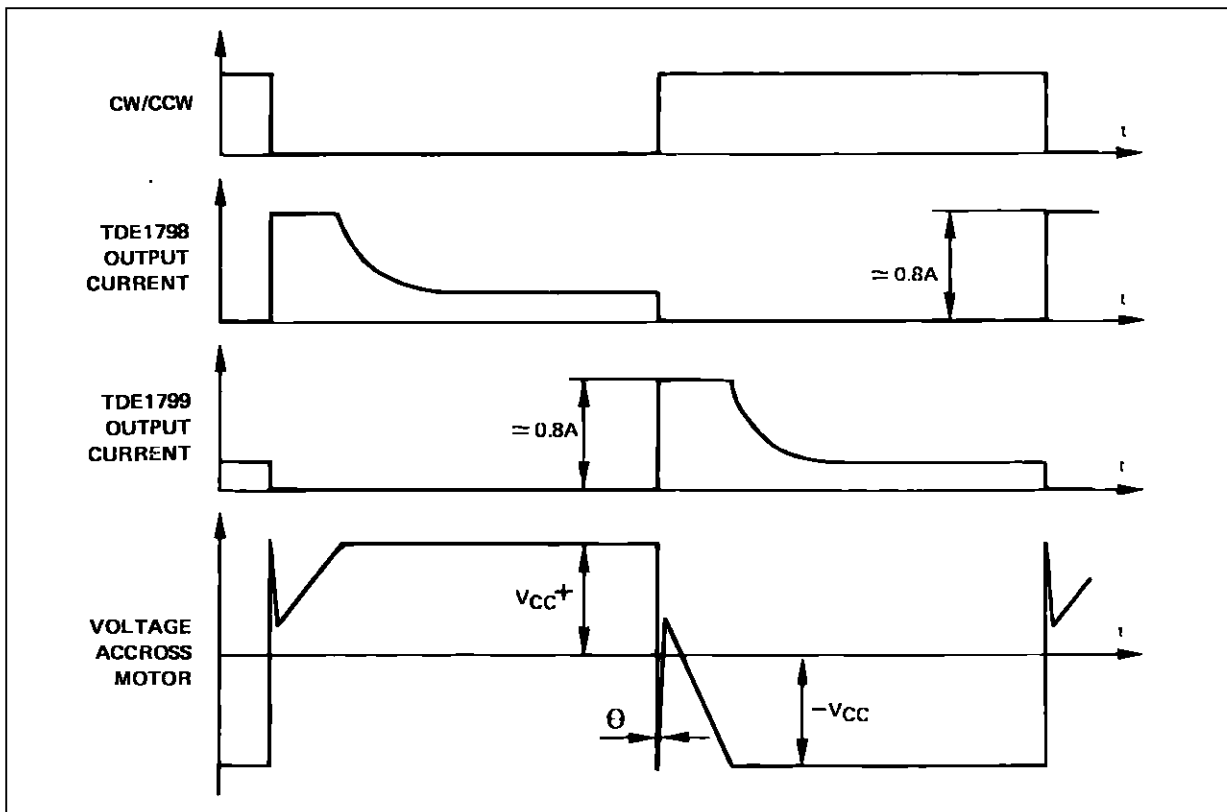

# TDE1798

## OVERLOAD CONDITIONS

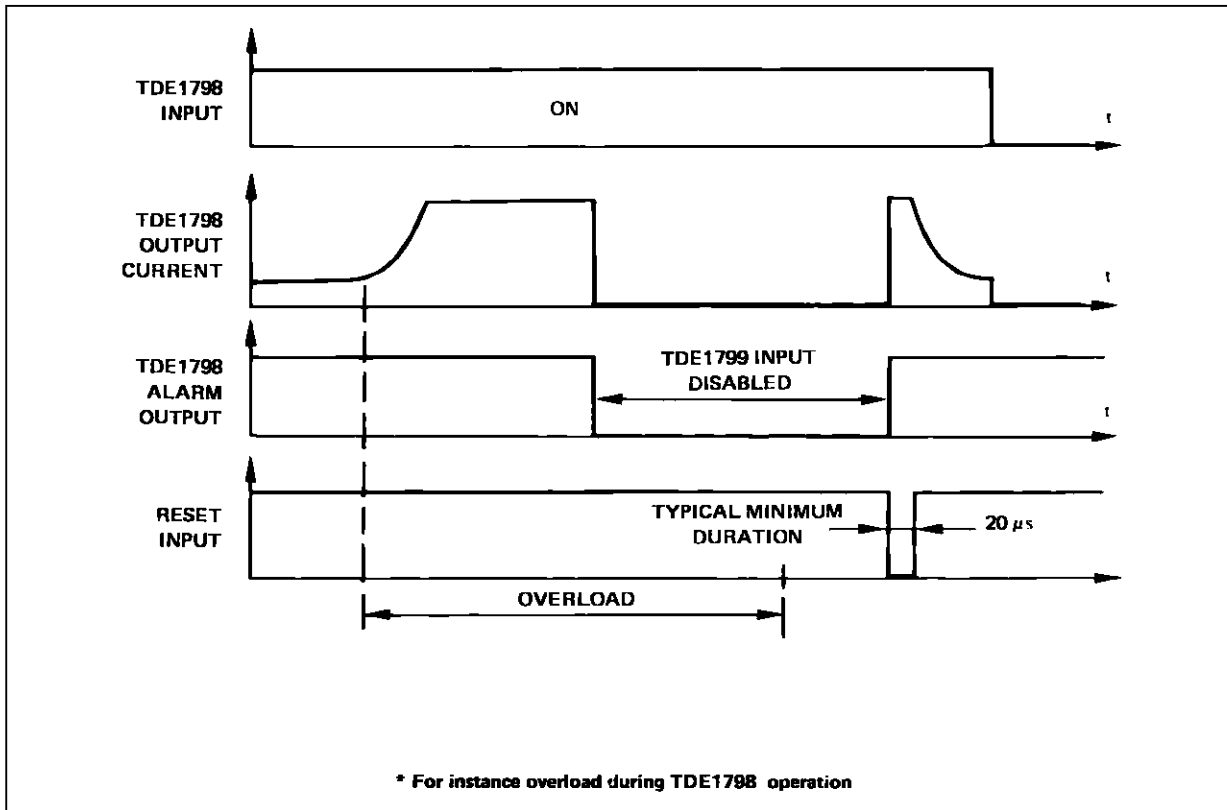

## MINIDIP PACKAGE MECHANICAL DATA

DIM.	mm			inch		
	MIN.	TYP.	MAX.	MIN.	TYP.	MAX.
A		3.32			0.131	
a1	0.51			0.020		
B	1.15		1.65	0.045		0.065
b	0.356		0.55	0.014		0.022
b1	0.204		0.304	0.008		0.012
D			10.92			0.430
E	7.95		9.75	0.313		0.384
e		2.54			0.100	
e3		7.62			0.300	
e4		7.62			0.300	
F			6.6			0.260
I			5.08			0.200
L	3.18		3.81	0.125		0.150
Z			1.52			0.060

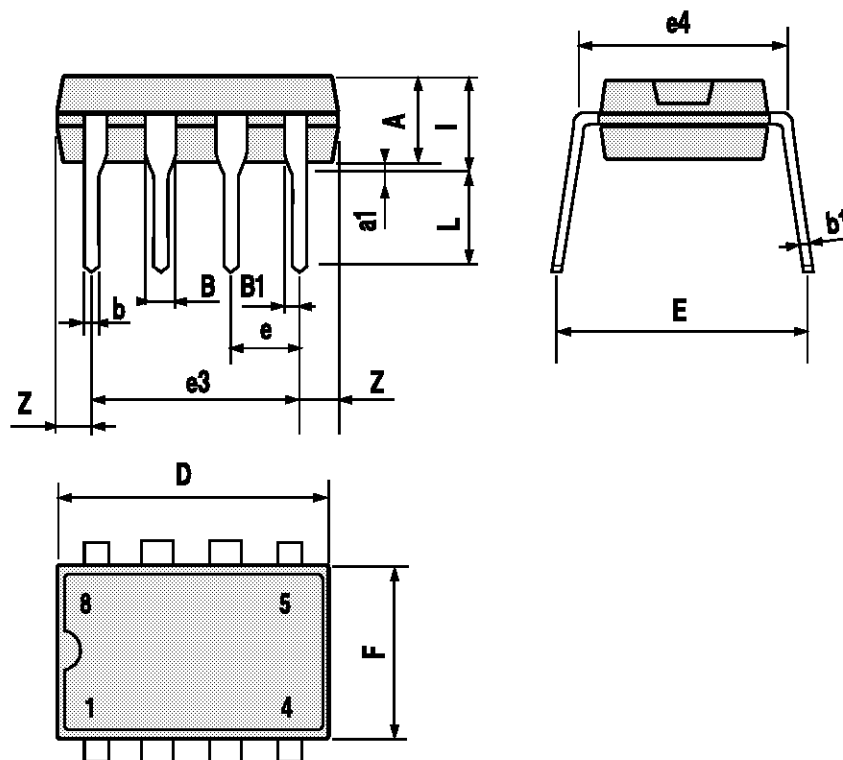

Information furnished is believed to be accurate and reliable. However, SGS-THOMSON Microelectronics assumes no responsibility for the consequences of use of such information nor for any infringement of patents or other rights of third parties which may result from its use. No license is granted by implication or otherwise under any patent or patent rights of SGS-THOMSON Microelectronics. Specifications mentioned in this publication are subject to change without notice. This publication supersedes and replaces all information previously supplied. SGS-THOMSON Microelectronics products are not authorized for use as critical components in life support devices or systems without express written approval of SGS-THOMSON Microelectronics.

© 1994 SGS-THOMSON Microelectronics - All Rights Reserved

SGS-THOMSON Microelectronics GROUP OF COMPANIES

Australia - Brazil - France - Germany - Hong Kong - Italy - Japan - Korea - Malaysia - Malta - Morocco - The Netherlands - Singapore - Spain - Sweden - Switzerland - Taiwan - Thailand - United Kingdom - U.S.A.