



TDA8174A

VERTICAL DEFLECTION CIRCUIT

- Ramp Generator
- Independent Amplitude Adjustment
- Buffer Stage
- Power Amplifier
- Flyback Generator
- Thermal Protection
- Internal Reference Voltage Decoupling

DESCRIPTION

TDA8174A and TDA8174AW are monolithic integrated circuits.

It is a full performance and very efficient vertical deflection circuit intended for direct drive of a TV picture tube in Color and B & W television as well as in Monitor and Data displays.

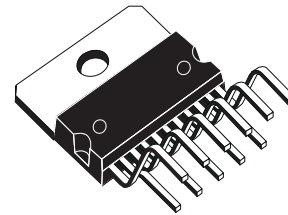

**MULTIWATT11
(Plastic Package)**

ORDER CODE: TDA8174A

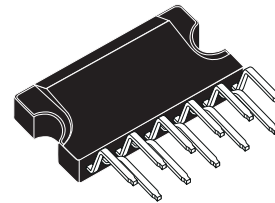

**CLIPWATT11
(Plastic Package)**

ORDER CODE: TDA8174AW

Figure 1. Pin Connections

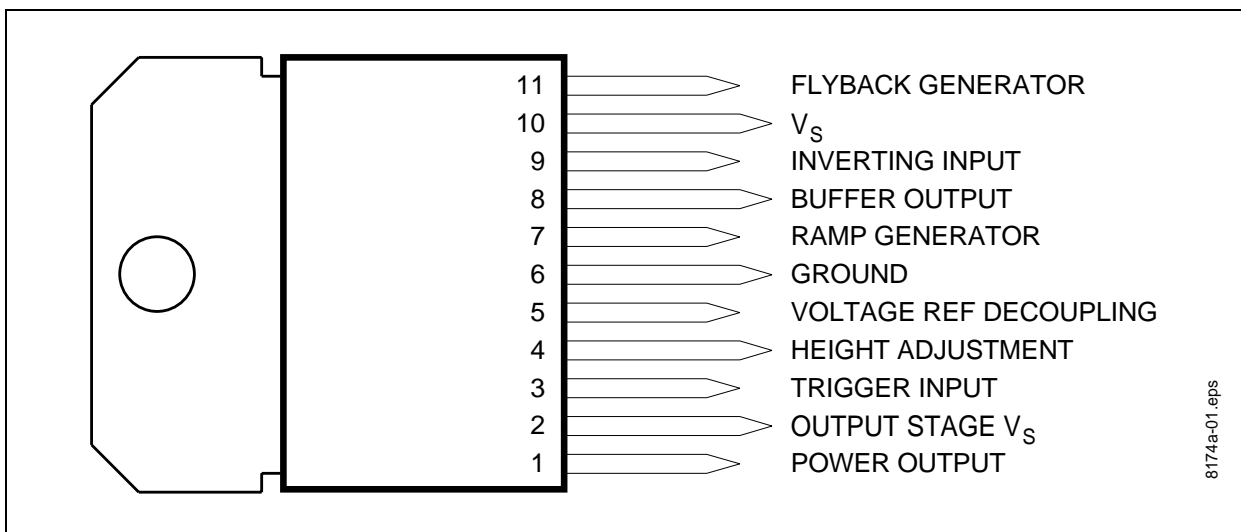

8174a-01.eps

TDA8174A

Figure 2. Block Diagram

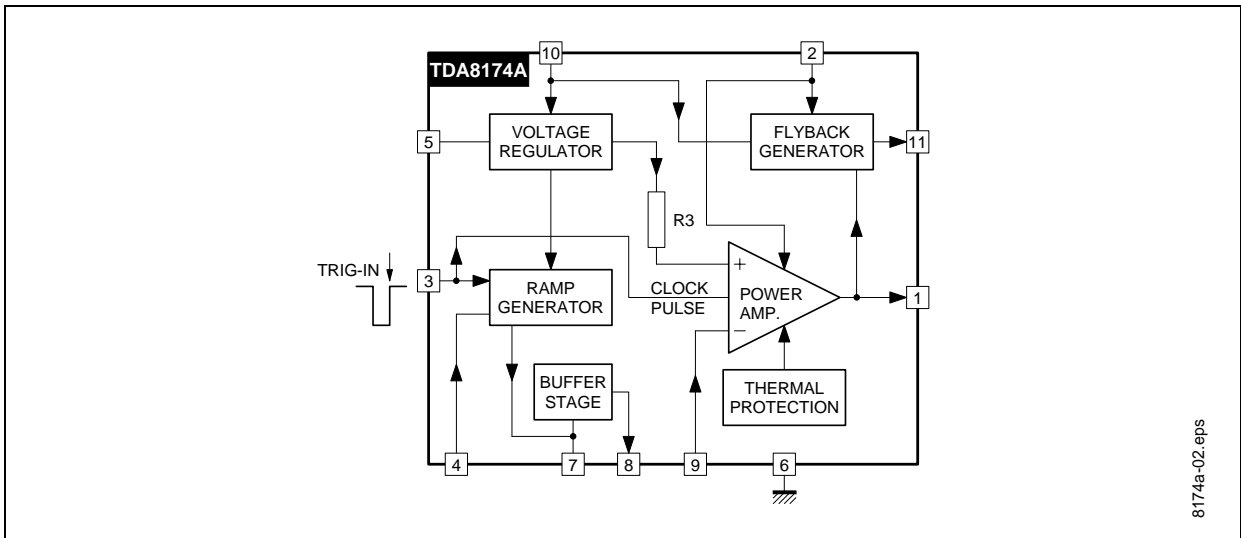

8174a-02.eps

ABSOLUTE MAXIMUM RATINGS

Symbol	Parameter	Value	Unit
V_S	Supply Voltage	35	V
V_1, V_2	Flyback Peak Voltage	65	V
V_3	Trigger Input Voltage	20	V
V_9	Amplifier Input Voltage	GND, V_S	V
I_0	Output Peak-to-peak Current (non repetitive $t = 2\text{ms}$)	6	A
I_0	Output Peak-to-peak Current $t > 10\mu\text{s}$	4	A
I_{11}	Pin 11 DC Current at $V_1 < V_{10}$	100	mA
I_{11}	Pin 11 Peak-to-peak Current @ $t_{flv} < 1.5\text{ms}$	3	A
P_{tot}	Total Power Dissipation @ $T_{tab} = 60^\circ\text{C}$	30	W
T_{stg}	Storage Temperature	- 40, +150	$^\circ\text{C}$
T_j	Junction Temperature	0, +150	$^\circ\text{C}$
T_{amb}	Ambient Temperature	0, +70	$^\circ\text{C}$

THERMAL DATA

Symbol	Parameter	Value	Unit
$R_{th(j-tab)}$	Thermal Resistance Junction-tab	Max. 3	$^\circ\text{C/W}$
$R_{th(j-a)}$	Thermal Resistance Junction-ambient	Max. 40	$^\circ\text{C/W}$

DC ELECTRICAL CHARACTERISTICS ($V_S = 35V$; $T_{amb} = 25^{\circ}C$ unless otherwise specified)

Symbol	Parameter	Test Conditions	Min.	Typ.	Max.	Unit
I_2	Pin 2 Quiescent Current	$I_1 = 0, I_{11} = 0$		16	36	mA
I_{10}	Pin 10 Quiescent Current	$I_1 = 0, I_{11} = 0$		15	30	mA
$-I_7$	Ramp Generator Bias Current	$V_7 = 0$			0.5	μA
$-I_7$	Ramp Generator Current	$V_7 = 0, -I_4 = 20\mu A$	18.5	20	21.5	μA
dI_7/I_7	Ramp Generator Linearity	$V_6 = 0$ to 15V, $-I_4 = 20\mu A$		0.2	1	%
V_1	Quiescent Output Voltage	$R_a = 30k\Omega, R_b = 10k\Omega, V_s = 35V$	17.0	17.8	18.6	V
		$R_a = 6.8k\Omega, R_b = 10k\Omega, V_s = 15V$	7.2	7.5	7.8	V
V_{1L}	Out Saturation Voltage to GND	$I_1 = 0.5A$		0.5	1	V
		$I_1 = 1.2A$		1	1.4	V
V_{1H}	Out Saturation Voltage to V_s	$-I_1 = 0.5A$		1.1	1.6	V
		$-I_1 = 1.2A$		1.6	2.2	V
V_4	Reference Voltage	$-I_4 = 20\mu A$	6.3	6.6	6.9	V
dV_4/V_s	Reference Voltage Drift Versus V_s	$V_s = 10V$ to 35V		1	2	mV/V
dV_4/dI_4	Reference Voltage Drift Versus I_4	$I_4 = 10\mu A$ to 30 μA		1.5	2	mV/ μA
V_5	Internal Reference Voltage		4.25	4.45	4.65	V
V_{D11-10}	Diode Fwd Voltage	$I_D = 1.2A$		2.2	3	V
V_{D1-2}	Diode Fwd Voltage	$I_D = 1.2A$		2.2	3	V
G_V	Output Stage Open Loop Gain	$f = 100Hz$		60		dB
V_{fs}	V_{10-11} Saturation Voltage	$-I_{11} = 1.2A$		1.5	2.5	V
V_{11}	Pin 11 Scanning Voltage	$I_{11} = 20mA$		1.7	3	V
V_3	Trigger Input Threshold	(see note 1)	2.6	3.0	3.4	V
I_3	Trigger Input Bias Current	$V_{IN} = V_3 - 0.2V$			30	μA
t_3	Trigger Input Width	(see note 2)	20	60	Th	μS

Notes:

- The trigger input circuit can accept, with a metal option, positive and negative going input pulses.
- $Th = \frac{1.2 \cdot T_S}{V_{PP}}$ where: T_S is the vertical period and V_{PP} is ramp amplitude at Pin7.

AC ELECTRICAL CHARACTERISTICS ($V_S = 24V$; $T_{amb} = 25^{\circ}C$ unless otherwise specified)

Symbol	Parameter	Test Conditions	Min.	Typ.	Max.	Unit
V_s	Operating Supply Voltage Range		10		30	V
I_1	Peak-to-peak Operating Current Range		0.4			A
I_s	Supply Current	$I_y = 2.4A_{pp}$		315		mA
V_1	Flyback Voltage	$I_y = 2.4A_{pp}$		51		V
V_8	Sawtooth Pedestall Voltage			1.85		V
T_{js}	Junction Temp. for Thermal Shutdown			145		$^{\circ}C$

TDA8174A

Figure 3. Application Circuit

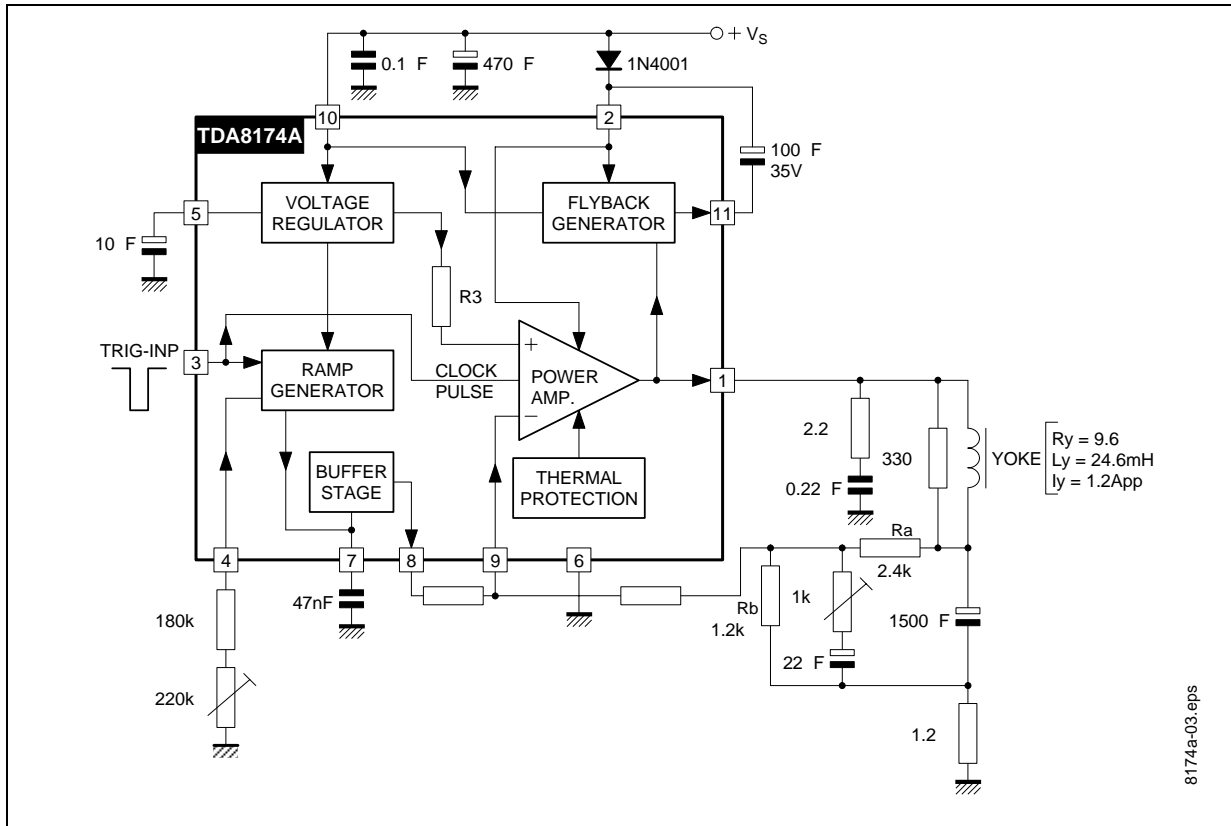

8174a-03.eps

PACKAGE MECHANICAL DATA

11 PINS - PLASTIC MULTIWATT

Figure 4. 11-Pin Package

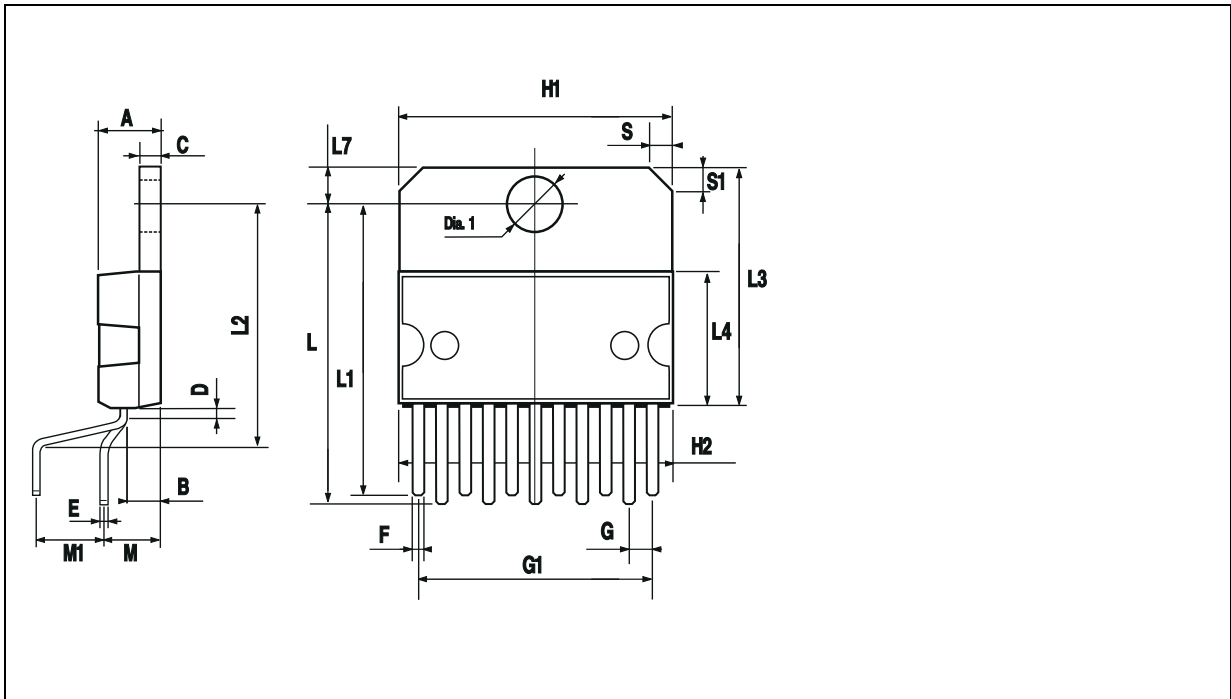

TDA8174A

PACKAGE MECHANICAL DATA (Cont'd)

11 PINS - PLASTIC CLIPWATT

Figure 5. 11-Pin Package

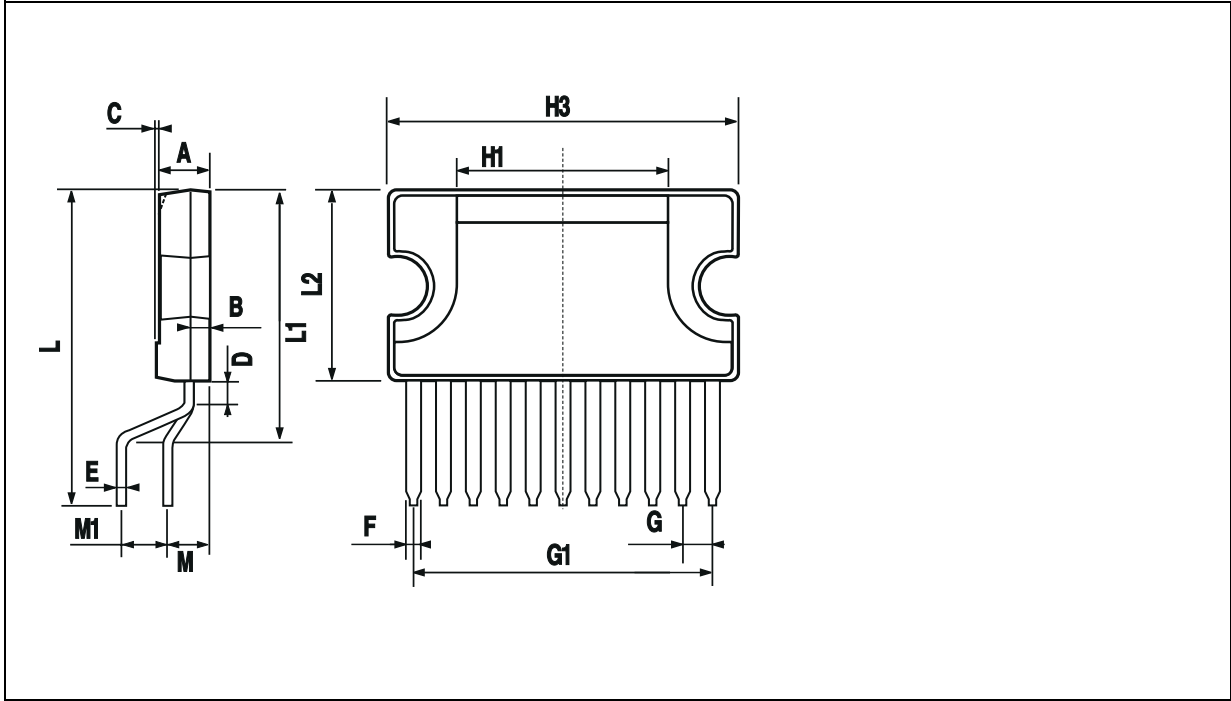

Information furnished is believed to be accurate and reliable. However, STMicroelectronics assumes no responsibility for the consequences of use of such information nor for any infringement of patents or other rights of third parties which may result from its use. No license is granted by implication or otherwise under any patent or patent rights of STMicroelectronics. Specifications mentioned in this publication are subject to change without notice. This publication supersedes and replaces all information previously supplied. STMicroelectronics products are not authorized for use as critical components in life support devices or systems without the express written approval of STMicroelectronics.

The ST logo is a registered trademark of STMicroelectronics

©2003 STMicroelectronics - All Rights Reserved.

Purchase of I²C Components by STMicroelectronics conveys a license under the Philips I²C Patent. Rights to use these components in an I²C system is granted provided that the system conforms to the I²C Standard Specification as defined by Philips.

STMicroelectronics Group of Companies

Australia - Brazil - China - Finland - France - Germany - Hong Kong - India - Italy - Japan - Malaysia - Malta - Morocco - Singapore - Spain
Sweden - Switzerland - United Kingdom - U.S.A.

<http://www.st.com>