

3 BAND CAR AUDIO PROCESSOR

1 FEATURES

- 4 STEREO INPUTS
- SOFT STEP VOLUME
- BASS, MIDDLE, TREBLE AND LOUDNESS
- DIRECT MUTE AND SOFTMUTE
- FOUR INDEPENDENT SPEAKER OUTPUTS
- SUB WOOFER OUTPUT
- SOFT STEP SPEAKER/SUBWOOFER CONTROL
- 7 BANDS SPECTRUM ANALYZER
- DIGITAL CONTROL:
 - I²C-BUS INTERFACE

2 DESCRIPTION

The TDA7419 is a high performance signal processor specifically designed for car radio applications. The device includes a high performance audiopro-

Figure 1. Package

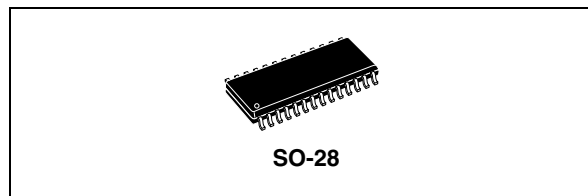

Table 1. Order Codes

Part Number	Package
TDA7419	SO-28
TDA7419TR	SO-28 in Tape & Reel

cessor with fully integrated audio filters. The digital control allows programming in a wide range of filter characteristics. By the use of BICMOS-process and linear signal processing low distortion and low noise are obtained.

Figure 2. Block Diagram

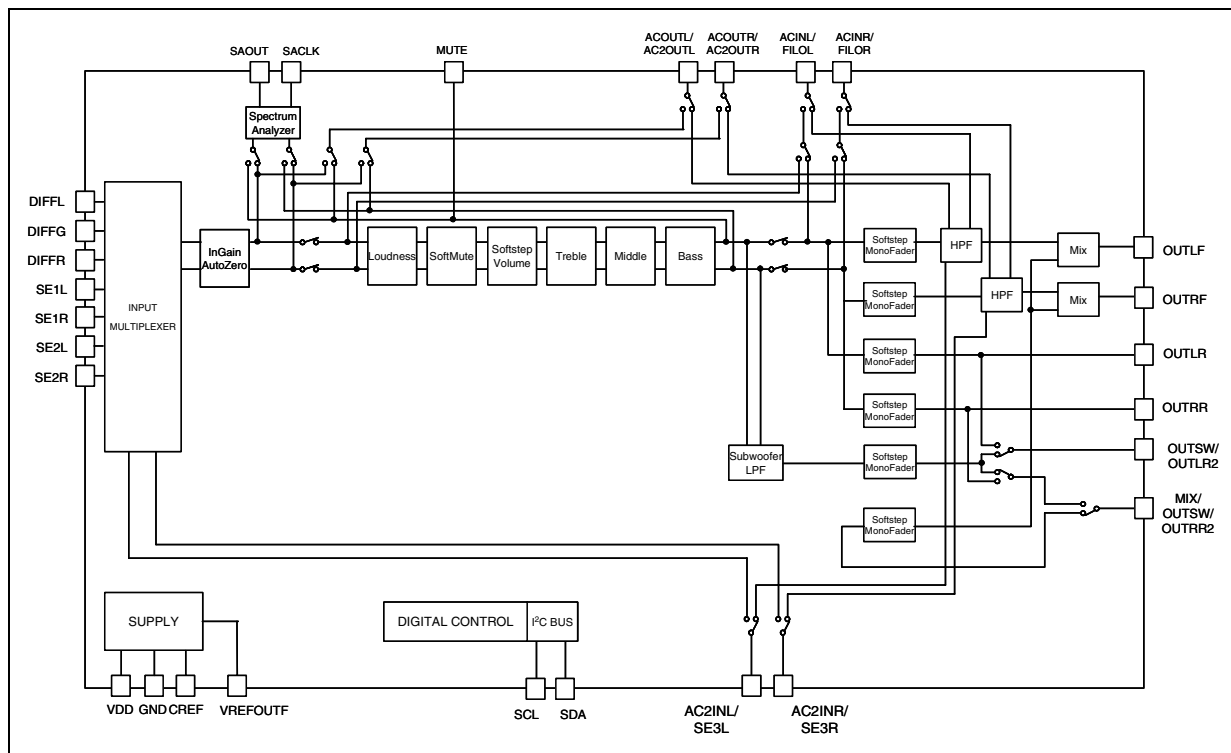

Table 2. Supply

Symbol	Parameter	Test Condition	Min.	Typ.	Max.	Unit
V _s	Supply Voltage		7.5	8.5	10.5	V
I _s	Supply Current	V _s = 8.5V	30	35	40	mA
SVRR	Ripple Rejection @ 1KHz	Audioprocessor(all Filters flat)	60			dB

Table 3. Thermal Data

Symbol	Parameter	Value	Unit
R _{Th j-pins}	Thermal Resistance Junction-pins max	85	°C/W

Table 4. Absolute Maximum Ratings

Symbol	Parameter	Value	Unit
V _s	Operating Supply Voltage	10.5	V
T _{amb}	Operating Temperature Range	-40 to 85	°C
T _{stg}	Storage Temperature Range	-55 to +150	°C

ESD

All pins are protected against ESD according to the MIL883 standard.

Figure 3. Pin connection (Top view)

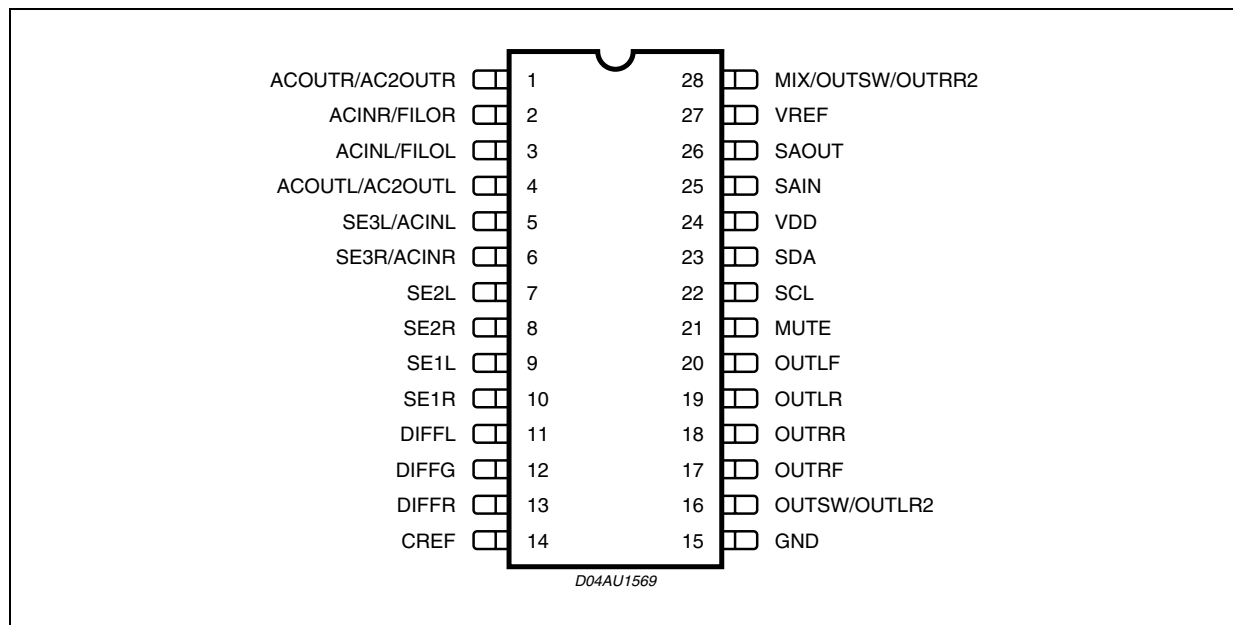

Table 5. Pin Description

Pin N#	Pin Name	Function	I/O
1	ACOUTR / AC2OUTR	AC coupling right output / DSO filter AC2OUT right channel	O
2	ACINR / FILOR	AC coupling right input / DSO filter FILO right channel	I/O
3	ACINL / FILOL	AC coupling left input / DSO filter FILO left channel	I/O
4	ACOUTL / AC2OUTL	AC coupling left output / DSO filter AC2OUT left channel	O
5	SE3L / ACINL	Single-ended input 3 left channel / AC coupling left input	I
6	SE3R / ACINR	Single-ended input 3 right channel / AC coupling right input	I
7	SE2L	Single-ended input 2 left channel	I
8	SE2R	Single-ended input 2 right channel	I
9	SE1L	Single-ended input 1 left channel	I
10	SE1R	Single-ended input 1 Right channel	I
11	DIFFL	Pseudo differential stereo input left	I
12	DIFFG	Pseudo differential stereo input common	I
13	DIFFR	Pseudo differential stereo input right	I
14	CREF	Reference capacitor	O
15	GND	Ground	S
16	OUTSW / OUTLR2	Subwoofer output / 2 nd rear left output	O
17	OUTRF	Front right output	O
18	OUTRR	Rear right output	O
19	OUTLR	Rear left output	O
20	OUTLF	Front left output	O
21	MUTE	External mute pin	I
22	SCL	I2C bus clock	I
23	SDA	I2C bus data	I/O
24	VDD	Supply	S
25	SAIN	Spectrum analyzer clock input	I
26	SAOUT	Spectrum analyzer output	O
27	VREF	Vref output	O
28	MIX / OUTSW / OUTRR2	Mix input / Additional subwoofer output / 2 nd rear right output	I/O

3 Audio Processor Features:

Input Multiplexer	<p>QD / SE: quasi-differential stereo inputs, with selectable single-ended mode SE1: stereo single-ended input SE2: stereo single-ended input SE3 / AC2IN: stereo single-ended input / DSO filter input In-Gain 0 to 15dB, 1dB steps internal offset-cancellation (AutoZero) separate second source-selector</p>
Mixing stage	mixable to front speaker-outputs
Loudness	<p>2nd order frequency response programmable center frequency (400Hz/800Hz/2400Hz) 15dB with 1dB steps selectable low & high frequency boost selectable flat-mode (constant attenuation)</p>
Volume	<p>+15dB to -79dB with 1dB step resolution soft-step control with programmable blend times</p>
Bass	<p>2nd order frequency response center frequency programmable in 4 steps (60Hz/80Hz/100Hz/200Hz) Q programmable 1.0/1.25/1.5/2.0 DC gain programmable -15 to 15dB range with 1dB resolution</p>
Middle	<p>2nd order frequency response center frequency programmable in 4 steps (500Hz/1KHz/1.5KHz/2.5KHz) Q programmable 0.5/0.75/1.0/1.25 DC gain programmable -15 to 15dB range with 1dB resolution</p>
Treble	<p>2nd order frequency response center frequency programmable in 4 steps (10KHz/12.5KHz/15KHz/17.5KHz) -15 to 15dB range with 1dB resolution</p>
Spectrum analyzer	<p>seven bandpass filters 2nd order frequency response programmable Q factor for different visual appearance analog output controlled by external serial clock</p>
Speaker	<p>4 independent soft step speaker controls, +15dB to -79dB with 1dB steps Independent programmable mix input with 50% mixing ratio for front speakers direct mute</p>
Subwoofer	<p>2nd order low pass filter with programmable cut off frequency single-ended mono output independent soft step level control, +15dB to -79dB with 1dB steps</p>
Mute Functions	<p>direct mute digitally controlled SoftMute with 3 programmable mute-times(0.48ms/0.96ms/ 123ms)</p>
Effect	gain effect, or high pass effect with fixed external components

4 ELECTRICAL CHARACTERISTICS

Table 6. Electrical Characteristics
 $V_S = 8.5V$; $T_{amb} = 25^{\circ}C$; $R_L = 10k\Omega$; all gains = 0dB; $f = 1kHz$; unless otherwise specified

Symbol	Parameter	Test Condition	Min.	Typ.	Max.	Unit
SUPPLY						
V_S	Supply Voltage		8	8.5	10	V
I_S	Supply Current		27	37	47	mA
INPUT SELECTOR						
R_{in}	Input Resistance	All single ended inputs	70	100	130	k Ω
V_{CL}	Clipping level	All Input	1.8	2		V_{RMS}
		QD input	1.7	2		V_{RMS}
S_{IN}	Input Separation		80	100		dB
$G_{IN\ MIN}$	Min. Input Gain		-1	0	1	dB
$G_{IN\ MAX}$	Max. Input Gain		13	15	17	dB
G_{STEP}	Step Resolution		0.5	1	1.5	dB
V_{DC}	DC Steps	Adjacent Gain Steps	-5	1	5	mV
		G_{MIN} to G_{MAX}	-20	4	20	mV
V_{offset}	Remaining offset with AutoZero			0.5		mV
DIFFERENTIAL STEREO INPUTS						
R_{in}	Input Resistance	Differential	70	100	130	K Ω
CMRR	Common Mode Rejection Ratio	$V_{CM} = 1\ VRMS @ 1kHz$	46	70		dB
		$V_{CM} = 1\ VRMS @ 10kHz$	46	60		dB
e_{No}	Output Noise @ Speaker Outputs	20Hz-20kHz, flat; all stages 0dB		12		μV
MIXING CONTROL						
M_{LEVEL}	Mixing Ratio	Main / Mix Source		-6/-6		dB
G_{MAX}	Max Gain		13	15	17	dB
A_{MAX}	Max Attenuation		-83	-79	-75	dB
A_{STEP}	Step Resolution		0.5	1	1.5	dB
LOUDNESS CONTROL						
A_{MAX}	Max Attenuation		-17	-15	-13	dB
A_{STEP}	Step Resolution		0.5	1	1.5	dB
f_{Peak}	Peak Frequency	f_{P1}	360	400	440	Hz
		f_{P2}	720	800	880	Hz
		f_{P3}	2200	2400	2600	Hz
VOLUME CONTROL						
G_{MAX}	Max Gain		13	15	17	dB
A_{MAX}	Max Attenuation		-83	-79	-75	dB
A_{STEP}	Step Resolution		0.5	1	1.5	dB
E_A	Attenuation Set Error	$G = -20$ to $+20dB$	-0.75	0	+0.75	dB
		$G = -79$ to $-20dB$	-4	0	3	dB
E_T	Tracking Error			2		dB
V_{DC}	DC Steps	Adjacent Attenuation Steps	-3	0.1	3	mV
		From 0dB to G_{MIN}	-5	0.5	5	mV

Table 6. Electrical Characteristics (continued)
 $V_S = 8.5V$; $T_{amb} = 25^\circ C$; $R_L = 10k\Omega$; all gains = 0dB; $f = 1kHz$; unless otherwise specified

Symbol	Parameter	Test Condition	Min.	Typ.	Max.	Unit
SOFT MUTE						
A_{MUTE}	Mute Attenuation		80	100		dB
T_D	Delay Time	T1		0.48	1	ms
		T2		0.96	2	ms
		T3	70	123	170	ms
$V_{TH\ Low}$	Low Threshold for SM Pin			1	V	
$V_{TH\ High}$	High Threshold for SM Pin		2.5		V	
R_{PU}	Internal pull-up resistor		32	45	58	$k\Omega$
V_{PU}	Internal pull-up Voltage			3.3		V
BASS CONTROL						
F_c	Center Frequency	f_{c1}	54	60	66	Hz
		f_{c2}	72	80	88	Hz
		f_{c3}	90	100	110	Hz
		f_{c4}	180	200	220	Hz
Q_{BASS}	Quality Factor	Q_1	0.9	1	1.1	
		Q_2	1.1	1.25	1.4	
		Q_3	1.3	1.5	1.7	
		Q_4	1.8	2	2.2	
C_{RANGE}	Control Range		± 14	± 15	± 16	dB
A_{STEP}	Step Resolution		0.5	1	1.5	dB
DC_{GAIN}	Bass-DC-Gain	DC = off	-1	0	+1	dB
		DC = on (shelving filter, use for cut only)		-4.4		dB
MIDDLE CONTROL						
C_{RANGE}	Control Range		± 14	± 15	± 16	dB
A_{STEP}	Step Resolution		0.5	1	1.5	dB
f_c	Center Frequency	f_{c1}	400	500	600	Hz
		f_{c2}	0.8	1	1.2	kHz
		f_{c3}	1.2	1.5	1.8	kHz
		f_{c4}	2	2.5	3	kHz
Q_{BASS}	Quality Factor	Q_1	0.45	0.5	0.55	
		Q_2	0.65	0.75	0.85	
		Q_3	0.9	1	1.1	
		Q_4	1.1	1.25	1.4	
TREBLE CONTROL						
C_{RANGE}	Clipping Level		± 14	± 15	± 16	dB
A_{STEP}	Step Resolution		0.5	1	1.5	dB
f_c	Center Frequency	f_{c1}	8	10	12	kHz
		f_{c2}	10	12.5	15	kHz
		f_{c3}	12	15	18	kHz
		f_{c4}	14	17.5	21	kHz

Table 6. Electrical Characteristics (continued)

$V_S = 8.5V$; $T_{amb} = 25^\circ C$; $R_L = 10k\Omega$; all gains = 0dB; $f = 1kHz$; unless otherwise specified

Symbol	Parameter	Test Condition	Min.	Typ.	Max.	Unit
SPEAKER ATTENUATORS						
G_{MAX}	Max Gain		14	15	16	dB
A_{MAX}	Max Attenuation		-83	-79	-75	dB
A_{STEP}	Step Resolution		0.5	1	1.5	dB
A_{MUTE}	Mute Attenuation		80	90		dB
E_E	Attenuation Set Error				2	dB
V_{DC}	DC Steps	Adjacent Attenuation Steps	-5	0.1	5	mV
AUDIO OUTPUTS						
V_{CL}	Clipping level	d = 0.3%	1.8	2		V_{RMS}
R_{OUT}	Output impedance			30	100	Ω
R_L	Output Load Resistance		2			k Ω
C_L	Output Load Capacitor				10	nF
V_{DC}	DC Voltage Level		3.8	4.0	4.2	V
SUBWOOFER ATTENUATOR						
G_{MAX}	Max Gain		14	15	16	dB
A_{MAX}	Max Attenuation		-83	-79	-75	dB
A_{STEP}	Step Resolution		0.5	1	1.5	dB
A_{MUTE}	Mute Attenuation		80	90		dB
E_E	Attenuation Set Error				2	dB
V_{DC}	DC Steps	Adjacent Attenuation Steps	-5	1	5	mV
SUBWOOFER LOWPASS						
f_{LP}	Lowpass Corner Frequency	f_{LP1}	72	80	88	Hz
		f_{LP2}	108	120	132	Hz
		f_{LP3}	144	160	176	Hz
HPF EFFECT						
G_{MAX}	Max Gain		21	22	23	dB
G_{MIN}	Min Gain		3	4	5	dB
A_{STEP}	Step Resolution		1.5	2	2.5	dB
SPECTRUM ANALYZER CONTROL						
V_{SAOut}	Output Voltage Range		0		3.3	V
f_{C1}	Center Frequency Band 1		5.5	62	69	Hz
f_{C2}	Center Frequency Band 2		141	157	173	Hz
f_{C3}	Center Frequency Band 3		356	392	436	Hz
f_{C4}	Center Frequency Band 4		0.9	1	1.1	kHz
f_{C5}	Center Frequency Band 5		2.26	2.51	2.76	kHz
f_{C6}	Center Frequency Band 6		5.70	6.34	6.98	kHz
f_{C7}	Center Frequency Band 7		14.4	16	17.6	kHz
Q	Quality Factor	Q1	1.62	1.8	1.98	
		Q2	3.15	3.5	3.85	
f_{SAClk}	Clock Frequency		3		100	kHz
t_{Sadel}	Analog Output Delay Time		2			μs

Table 6. Electrical Characteristics (continued)

$V_S = 8.5V$; $T_{amb} = 25^{\circ}C$; $R_L = 10k\Omega$; all gains = 0dB; $f = 1kHz$; unless otherwise specified

Symbol	Parameter	Test Condition	Min.	Typ.	Max.	Unit
t_{repeat}	Spectrum Analyzer Repeat Time		50			ms
t_{intres}	Internal Reset Time			4.5		ms
GENERAL						
e_{NO}	Output Noise	BW=20Hz to 20 kHz all gain = 0dB		12	20	μV
		BW=20Hz to 20 kHz Output muted		6	15	μV
S/N	Signal to Noise Ratio	all gain = 0dB flat; $V_o = 2V_{RMS}$		100		dB
D	Distortion	$V_{IN} = 1V_{RMS}$; all stages 0dB		0.01	0.1	%
S_C	Channel Separation left/right		80	90		dB

5 DESCRIPTION OF THE AUDIOPROCESSOR

5.1 Input stages

In the basic configuration, one stereo quasi-differential and three (two in case of DSO applications) single ended stereo inputs are available.

5.1.1 Quasi-differential stereo Input (QD)

The QD input is implemented as a buffered quasi-differential stereo stage with 100k input-impedance at each input. The attenuation is fixed to -3dB in order to adapt the incoming signal level.

5.1.2 Single-ended stereo input (SE1, SE2, SE3/AC2IN)

The input-impedance at each input is 100k and the attenuation is fixed to -3dB for incoming signals. The input for SE3 is also configurable as part of the interface for external filters in DSO applications (AC2IN)

Figure 4. Input Stage

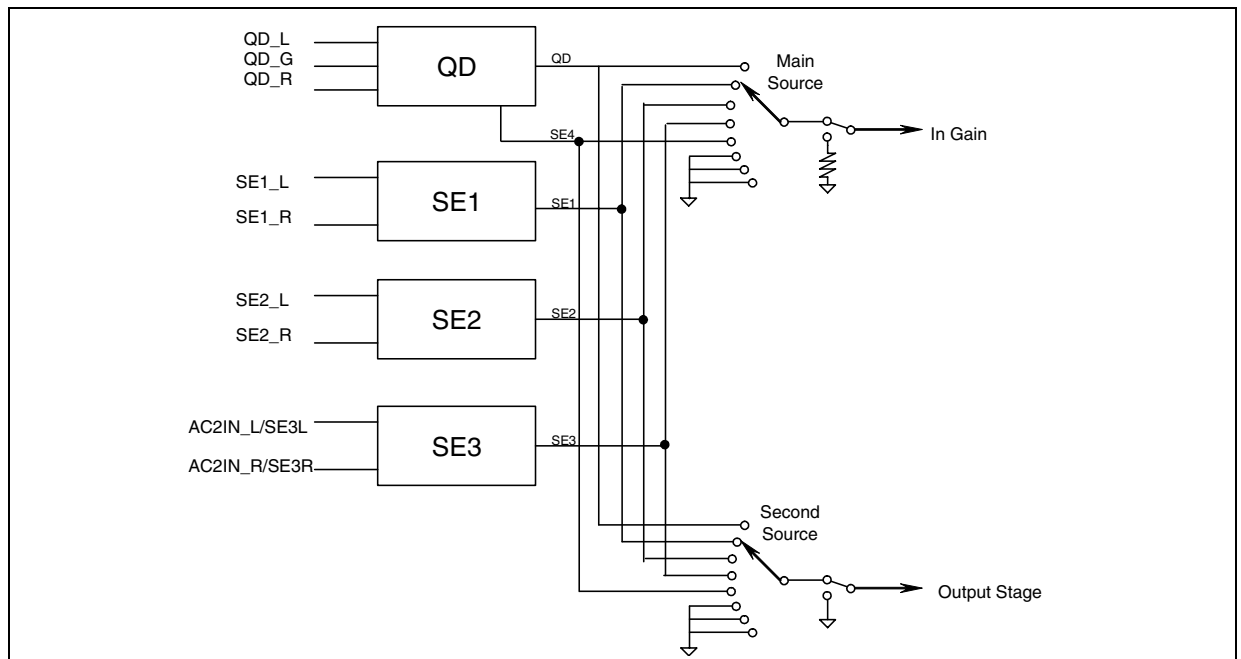

5.2 AutoZero

The AutoZero allows a reduction of the number of pins as well as external components by canceling any offset generated by or before the In-Gain-stage (Please notice that externally generated offsets, e.g. generated through the leakage current of the coupling capacitors, are not canceled).

The auto-zeroing is started every time the input source is changed and needs max. 0.3ms for the alignment. To avoid audible clicks the Audio processor is muted before the loudness stage during this time. The AutoZero feature is only present in the main signal-path.

5.2.1 AutoZero-Remain

In some cases, for example if the P is executing a refresh cycle of the IIC-Bus-programming, it is not useful to start a new AutoZero-action because no new source is selected and an undesired mute would appear at the outputs. For such applications, it can be switched in the AutoZero-Remain-Mode (Bit 6 of the subaddress-byte). If this bit is set to high, the AutoZero will not be invoked and the old adjustment-value remains.

5.3 Loudness

There are four parameters programmable in the loudness stage:

5.3.1 Attenuation

Figure 5 shows the attenuation as a function of frequency at $f_p = 400\text{Hz}$

Figure 5. Loudness Attenuation @ $f_p = 400\text{Hz}$.

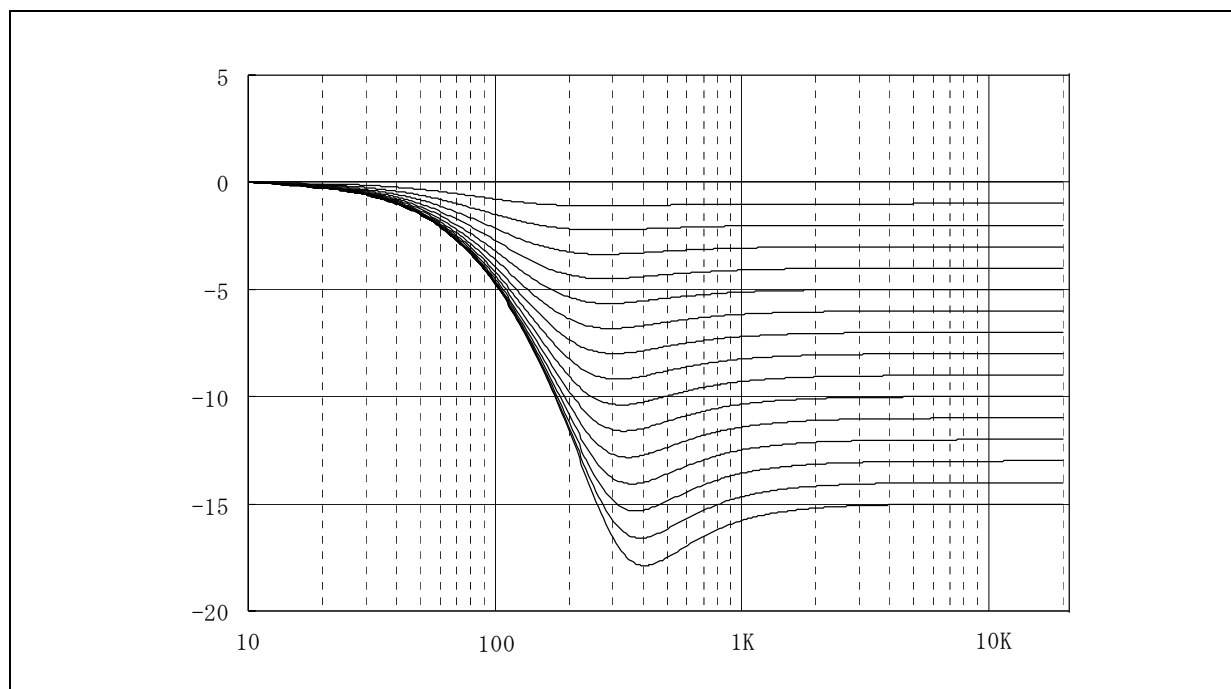

5.3.2 Peakr Frequency

Figure 6 shows the three possible peak-frequencies 400Hz , 800Hz and 2.4kHz.

Figure 6. Loudness Center frequencies @ Attn. = 15dB

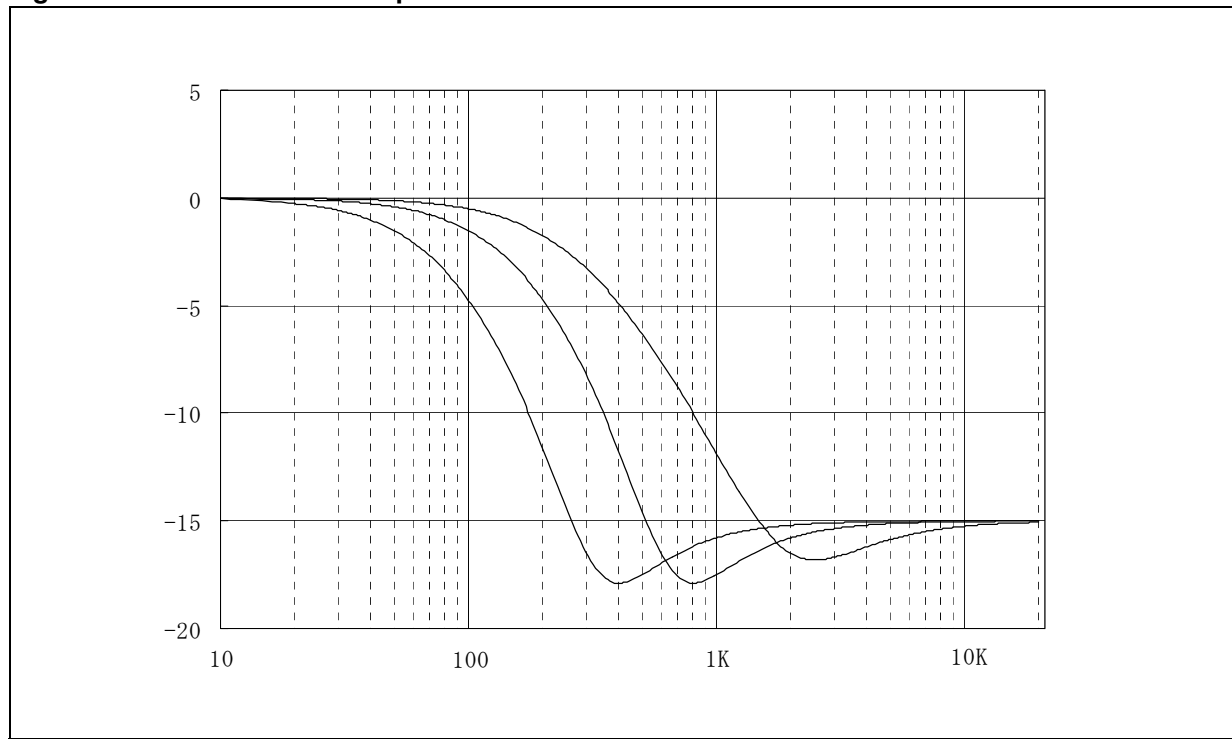

5.3.3 Low & High Frequency Boost

Figure 7 shows the different Loudness-shapes in low & high frequency boost.

Figure 7. Loudness Attenuation , $f_c = 2.4\text{KHz}$

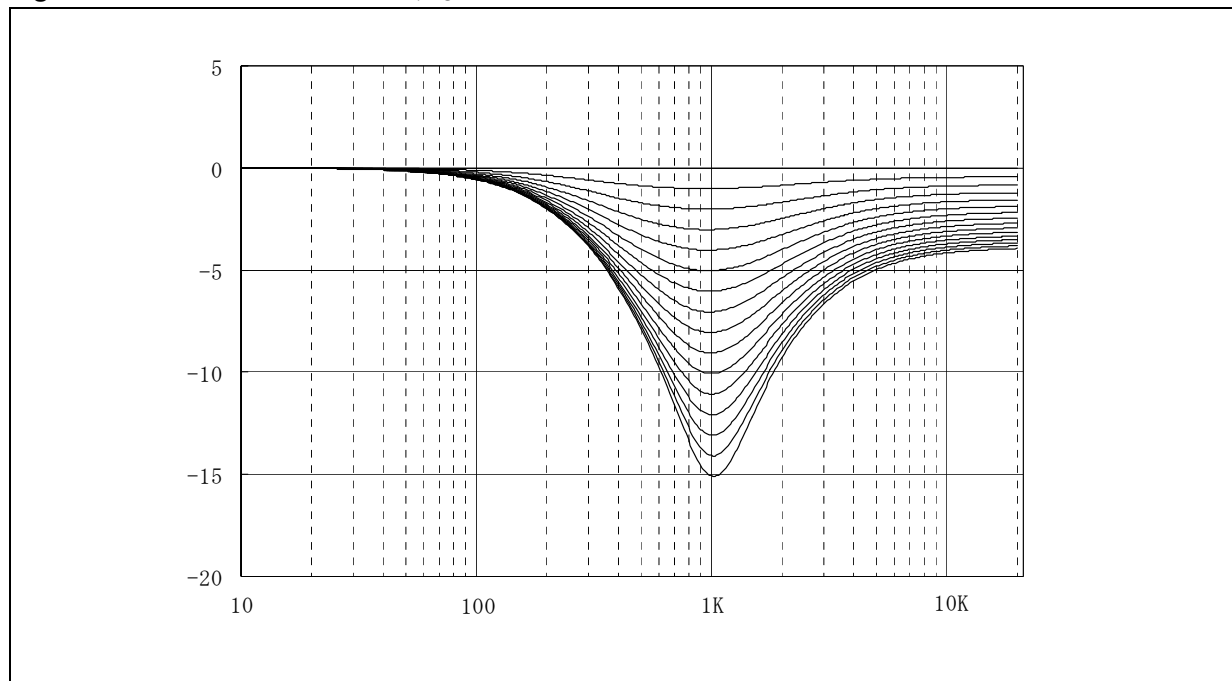

5.3.4 Flat Mode

In flat mode the loudness stage works as a 0dB to -15dB attenuator.

5.4 SoftMute

The digitally controlled SoftMute stage allows muting/demuting the signal with a I²C-bus programmable slope. The mute process can either be activated by the SoftMute pin or by the I²C-bus. This slope is realized in a special S-shaped curve to mute slow in the critical regions (see Figure 8).

For timing purposes the Bit0 of the I2C-bus output register is set to 1 from the start of muting until the end of demuting.

Figure 8. Sofmute Timing

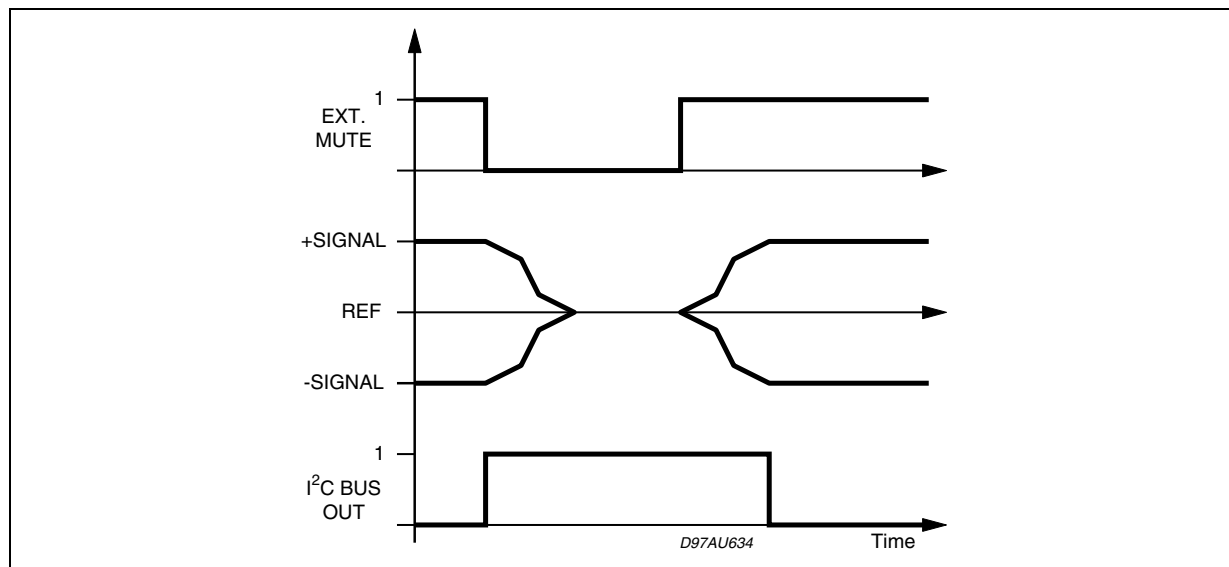

Note: Please notice that a started Mute-action is always terminated and could not be interrupted by a change of the mute -signal

5.5 SoftStep-Volume

When the volume-level is changed audible clicks could appear at the output. The root cause of those clicks could either be a DC-Offset before the volume-stage or the sudden change of the envelope of the audio-signal. With the SoftStep feature both kinds of clicks could be reduced to a minimum and are no more audible. The blend-time from one step to the next is programmable in four steps.

Figure 9. SoftStep Timing

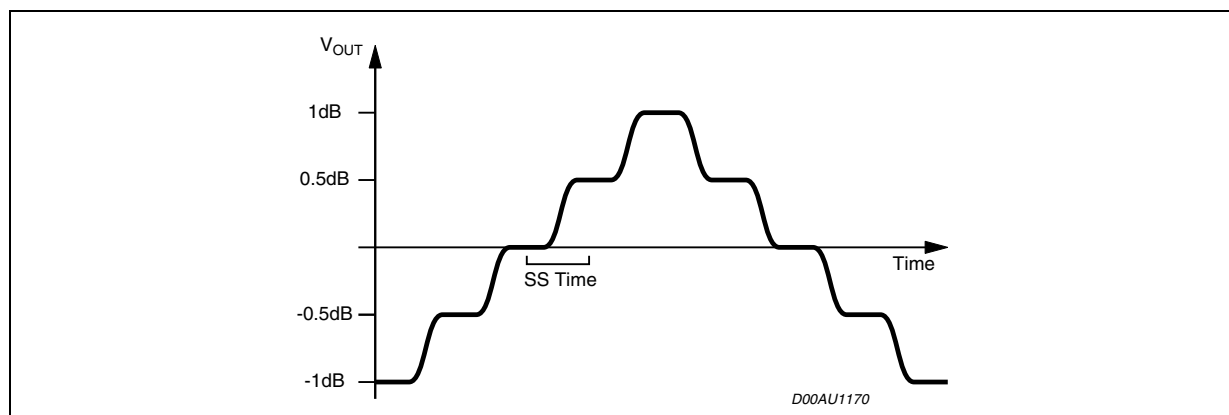

Note: For steps more than 0.5dB the SoftStep mode should be deactivated because it could generate a hard 1dB step during the blend-time.

5.6 Bass

There are four parameters programmable in the bass stage:

5.6.1 Attenuation

Figure 9 shows the attenuation as a function of frequency at a center frequency of 80Hz.

Figure 10. Bass Control @ $f_C = 80\text{Hz}$, $Q = 1$

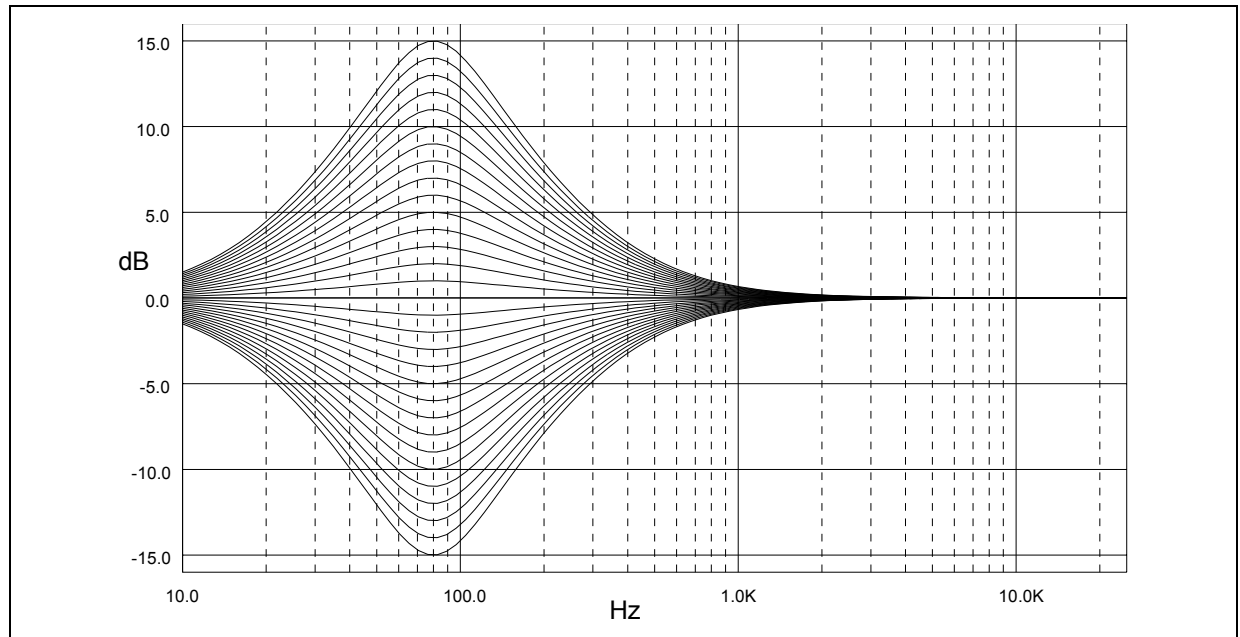

5.6.2 Center Frequency

Figure 11 shows the four possible center frequencies 60, 80, 100 and 200Hz.

Figure 11. Bass center Frequencies @ Gain = 15dB, Q = 1

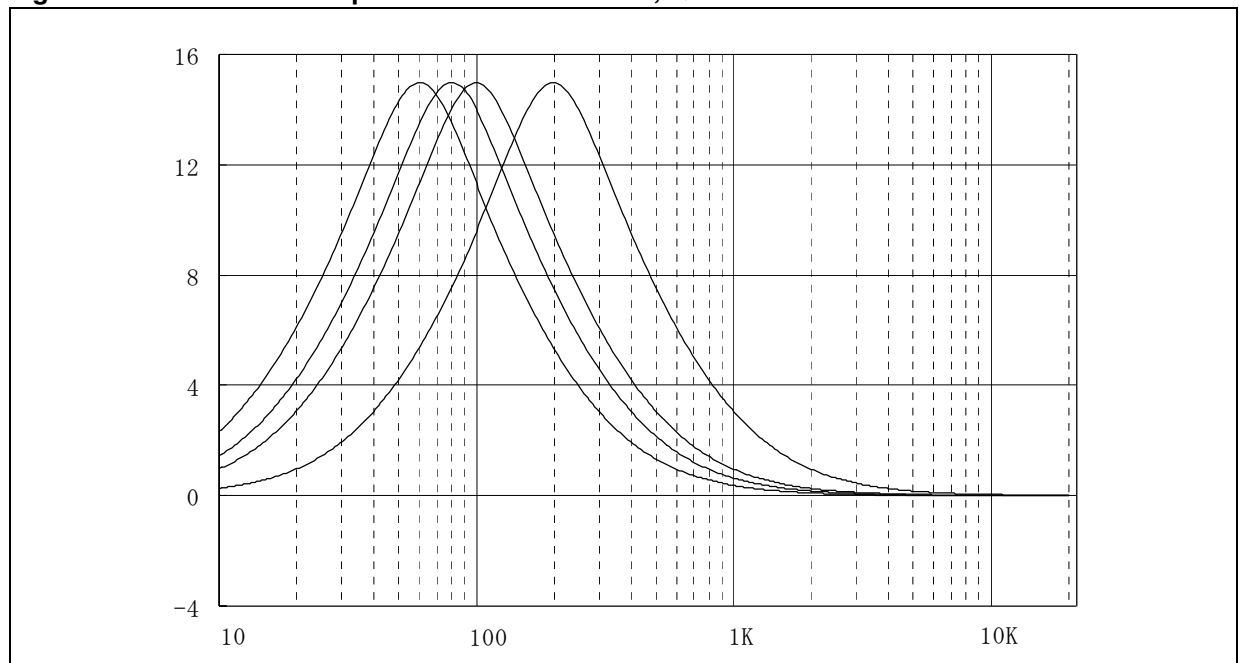

5.6.3 Quality Factors

Figure 12 shows the four possible quality factors 1, 1.25, 1.5 and 2.

Figure 12. Bass Quality factors @ Gain = 14dB, $f_C = 80\text{Hz}$

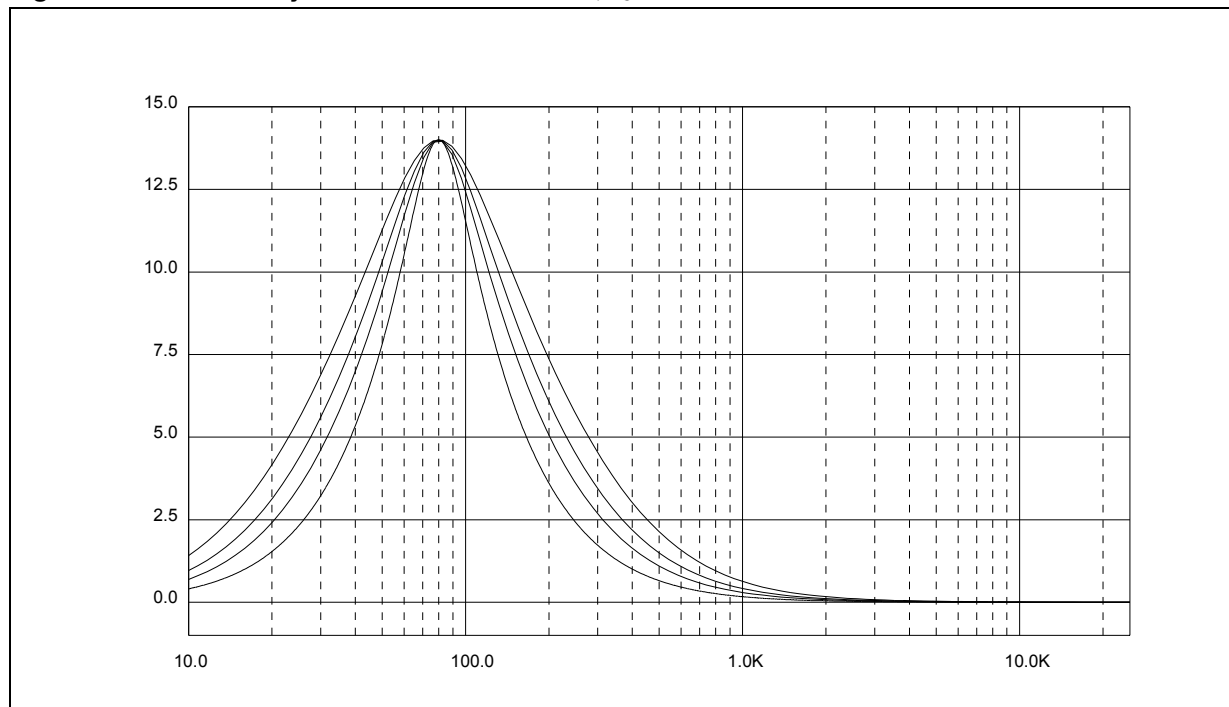

5.6.4 DC Mode

It is used for cut only for shelving filter. In this mode the DC-gain is increased by 4.4dB. In addition the programmed center frequency and quality factor is decreased by 25% which can be used to reach alternative center frequencies or quality factors.

Figure 13. Bass normal and DC Mode @ Gain = 14dB, $f_C = 80\text{Hz}$

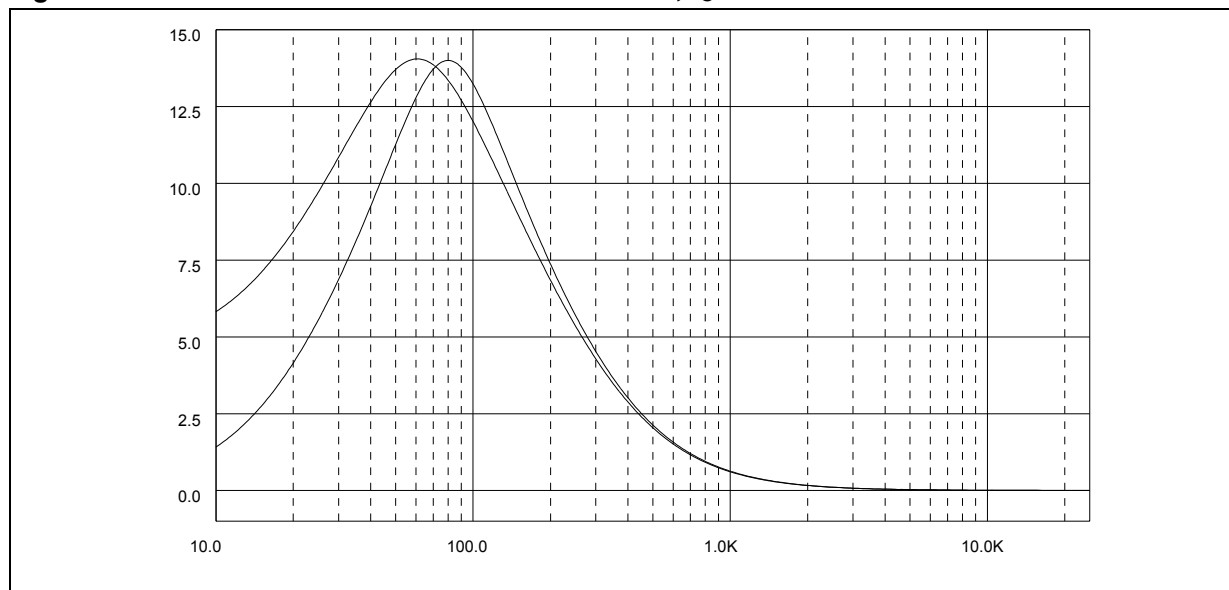

Note: The center frequency, Q and DC-mode can be set fully independently.

5.7 Middle

There are three parameters programmable in the middle stage:

5.7.1 Attenuation

Figure 14 shows the attenuation as a function of frequency at a center frequency of 1kHz.

Figure 14. Middle Control @ $f_C = 1$ kHz, $Q = 1$

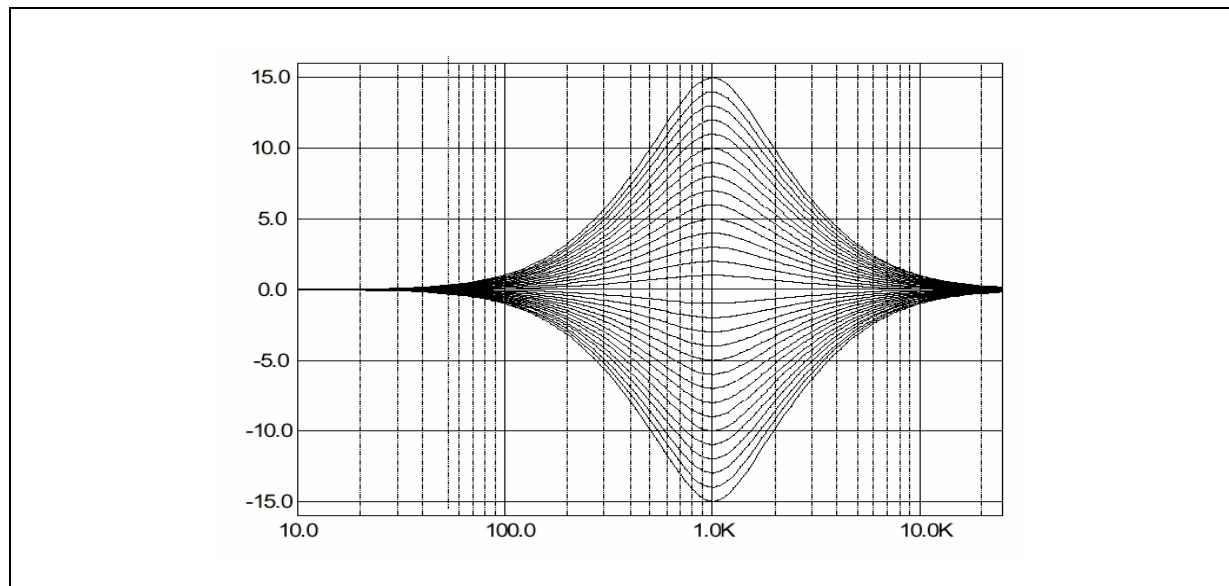

5.7.2 Center Frequency

Figure 14 shows the four possible center frequencies 500Hz, 1kHz, 1.5kHz and 2.5kHz.

Figure 15. Middle center Frequencies @ Gain = 14dB, $Q = 1$

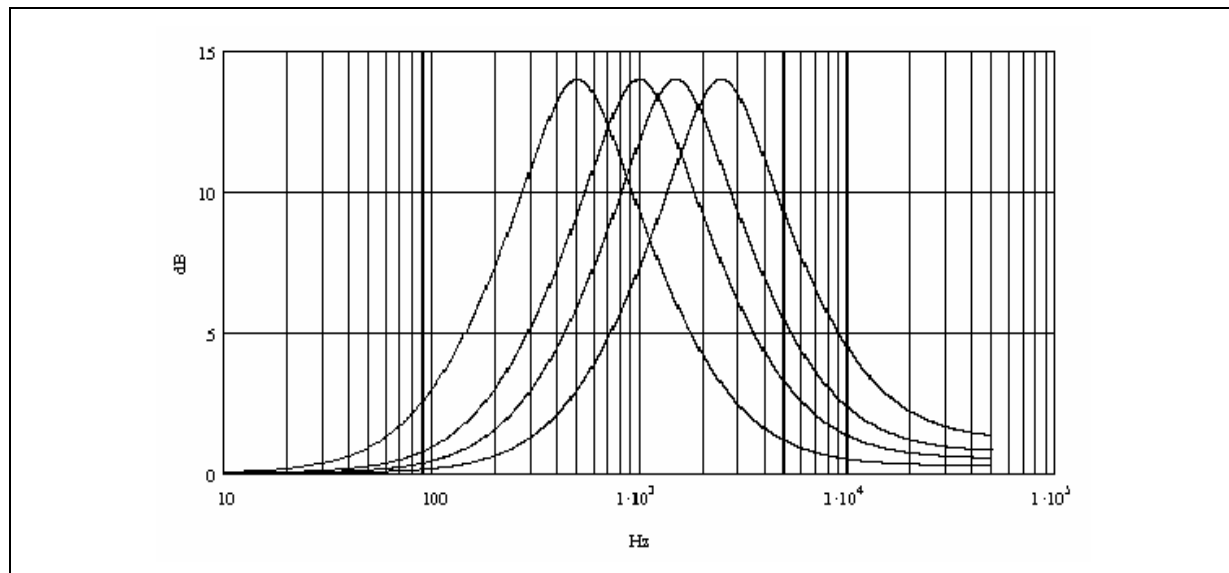

5.7.3 Quality Factors

Figure 16 shows the four possible quality factors 0.5, 0.75, 1 and 1.25.

Figure 16. Middle Quality factors @ Gain = 14dB, $f_c = 1\text{kHz}$

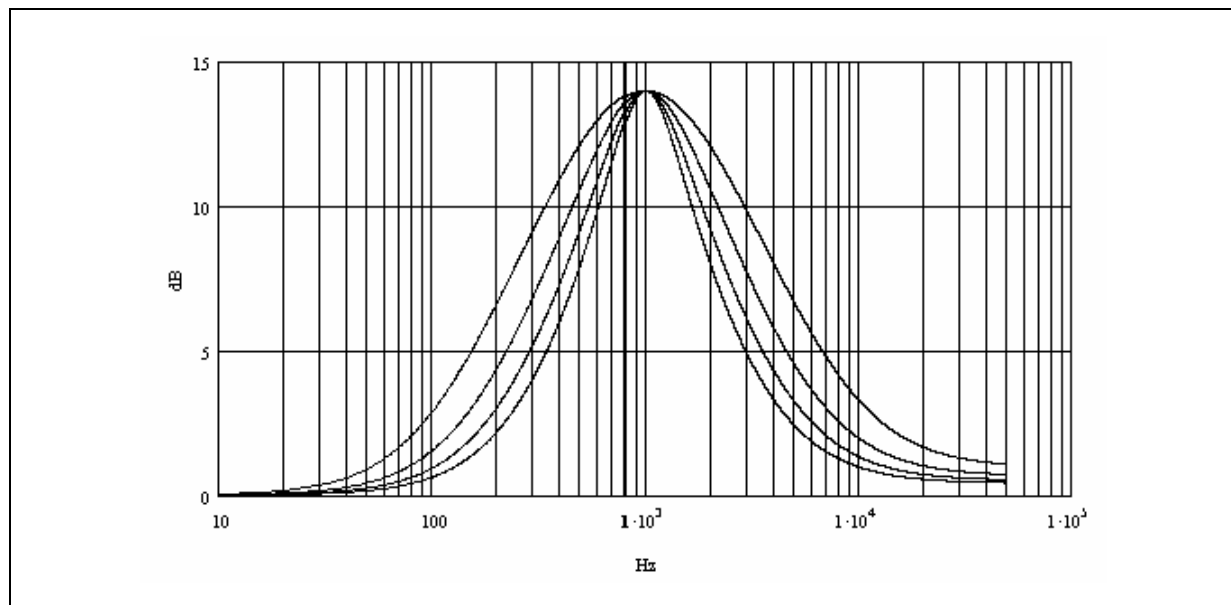

5.8 Treble

There are two parameters programmable in the treble stage:

5.8.1 Attenuation

Figure 16 shows the attenuation as a function of frequency at a center frequency of 17.5kHz.

Figure 17. Treble Control @ $f_c = 17.5\text{kHz}$

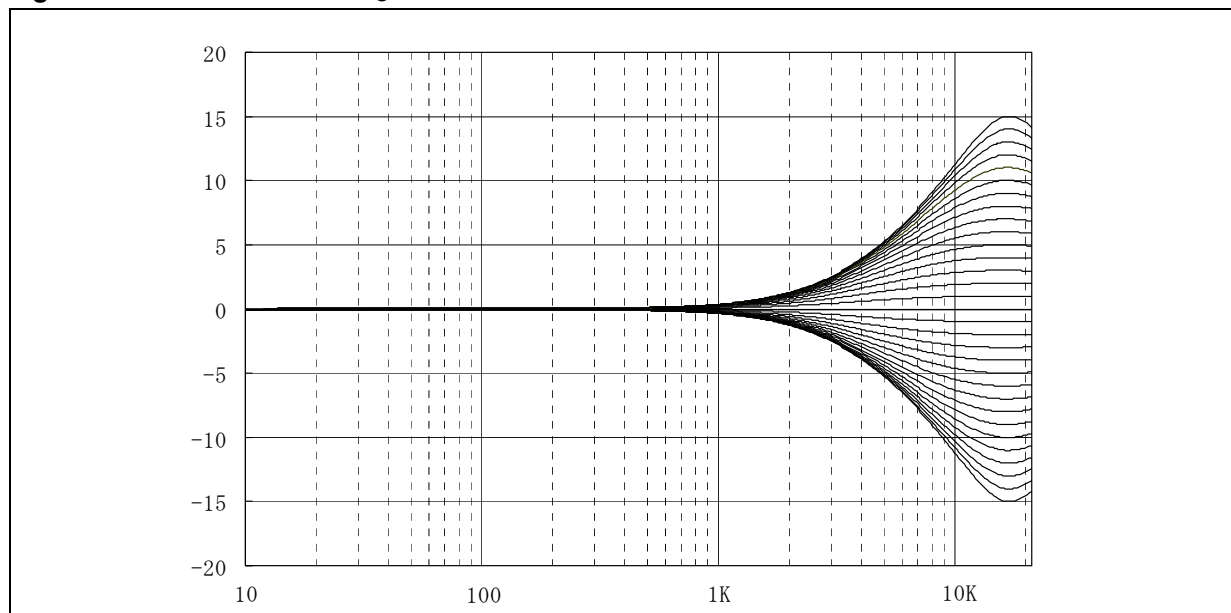

5.8.2 Center Frequency

Figure 18 shows the four possible center frequencies 10k, 12.5k, 15k and 17.5kHz.

Figure 18. Treble Center Frequencies @ Gain = 15dB

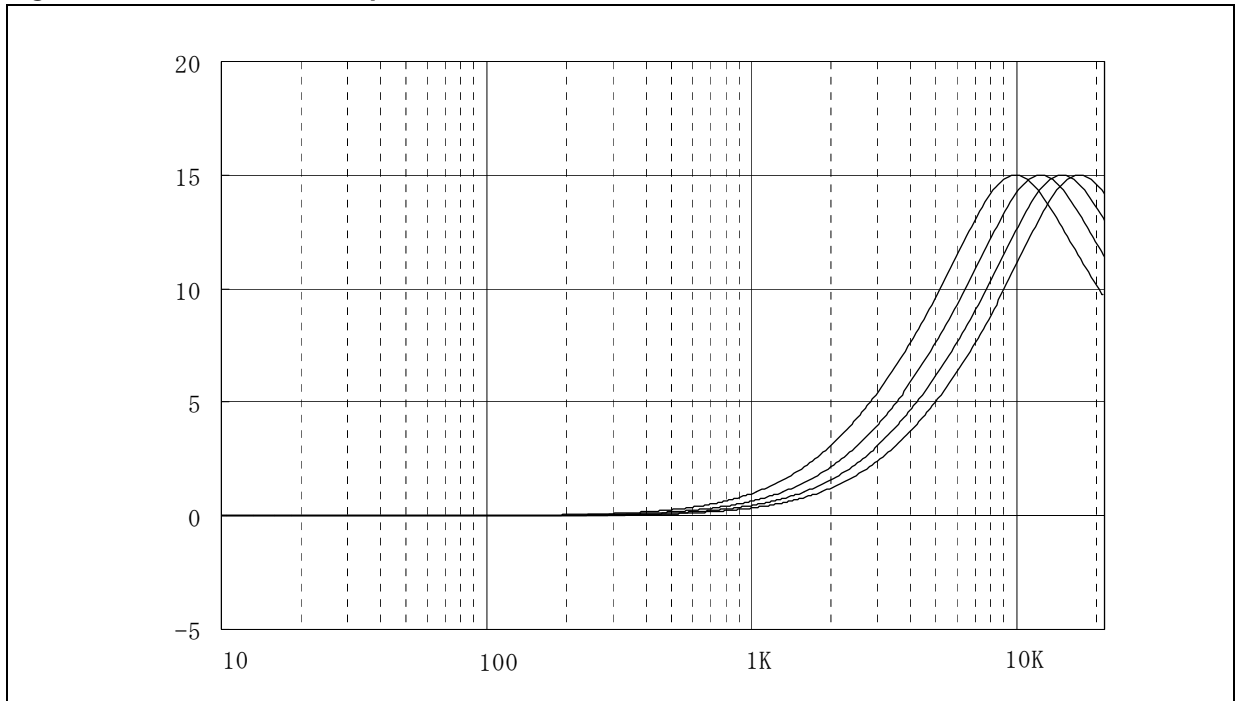

5.9 Subwoofer Filter

The subwoofer lowpass filter has butterworth characteristics with programmable cut-off frequency (80/120/160Hz)

Figure 19. Subwoofer Control

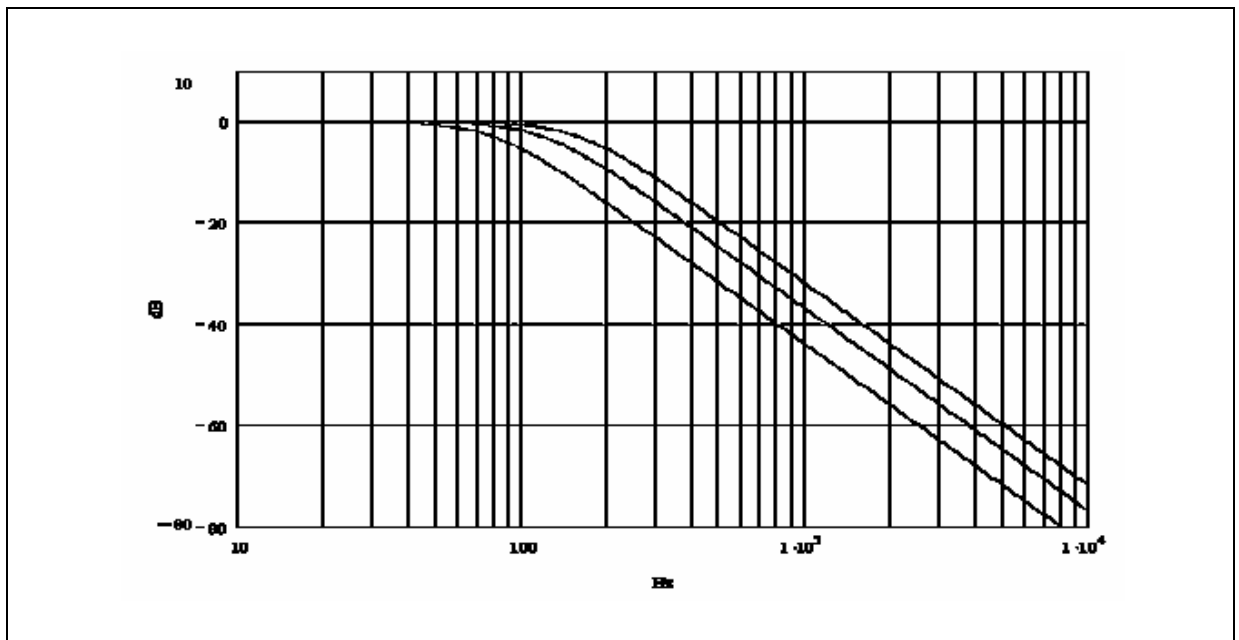

5.10 Spectrum Analyzer

A fully integrated seven-band spectrum analyzer with programmable quality factor is present. The spectrum analyzer consists of seven band pass filters with rectifier and sample capacitor that stores the maximum peak signal level since the last read cycle. This peak signal level can be read by a microprocessor at the SAout-pin. To allow easy interfacing to an analog port of the microprocessor, the output voltage at this pin is referred to device ground.

The microprocessor starts a read cycle with the negative going clock edge at the SAck input. On the following positive clock edges, the peak signal level for the band pass filters is subsequently switched to SAout. Each analog output data is valid after the time t_{SAdel} . A reset of the sample capacitors is induced whenever SAck remains high for the time t_{inres} . Note that a proper reset requires the clock signal SAck to be held at high potential.

Figure 20. Spectrum analyzer block diagram

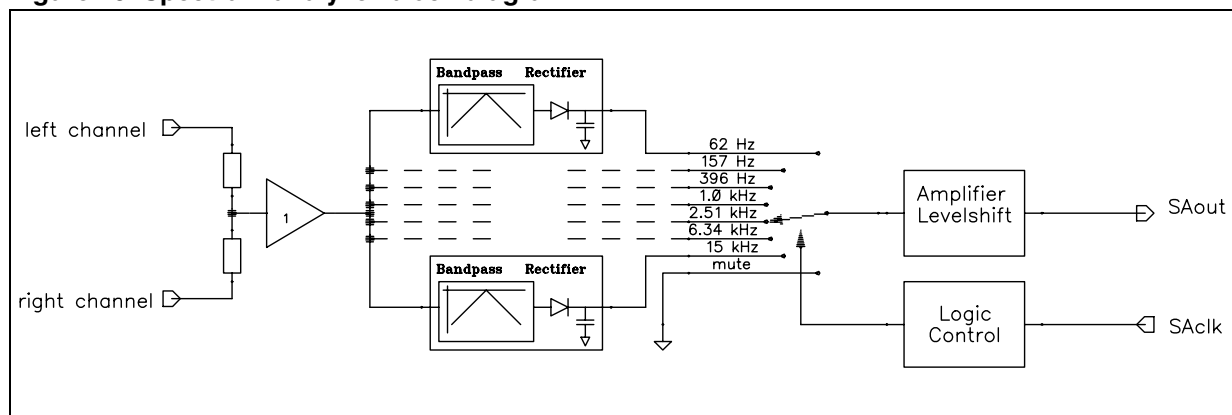
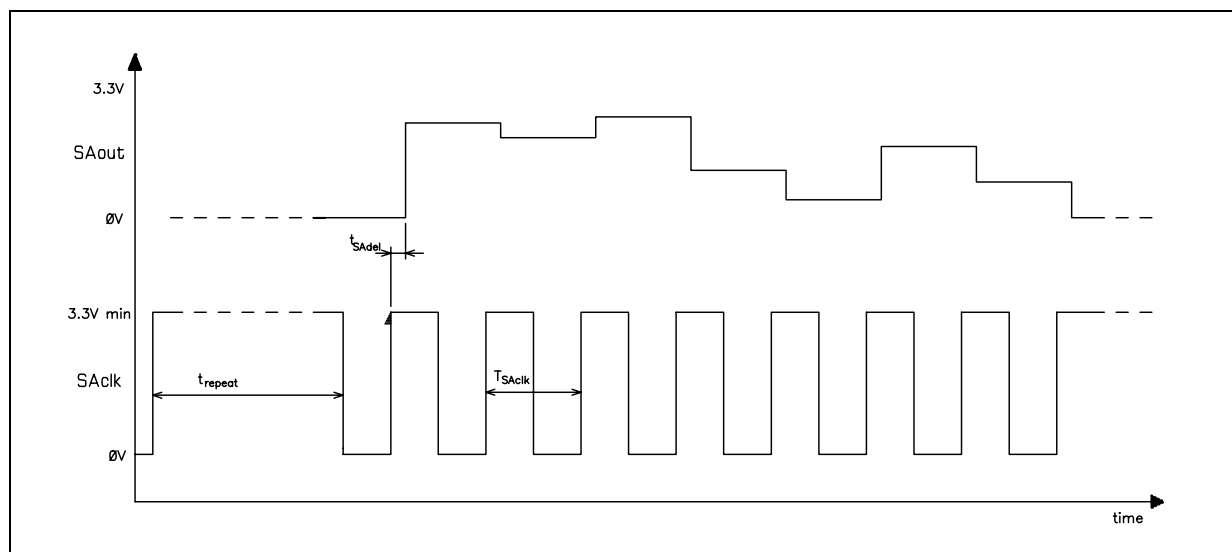

Figure 21. Timing of the spectrum analyzer



5.11 AC-Coupling

In some applications additional signal manipulations are desired, such as additional band equalizations. For this purpose, an AC-Coupling can be placed before the loudness attenuator or speaker-attenuators, which can be activated or internally shorted by I²C-Bus. In short condition, the input-signal of the speaker-attenuator is available at the AC-Outputs. The input-impedance of this AC-Inputs is 50kΩ.

Figure 22. Diagram of AC coupling

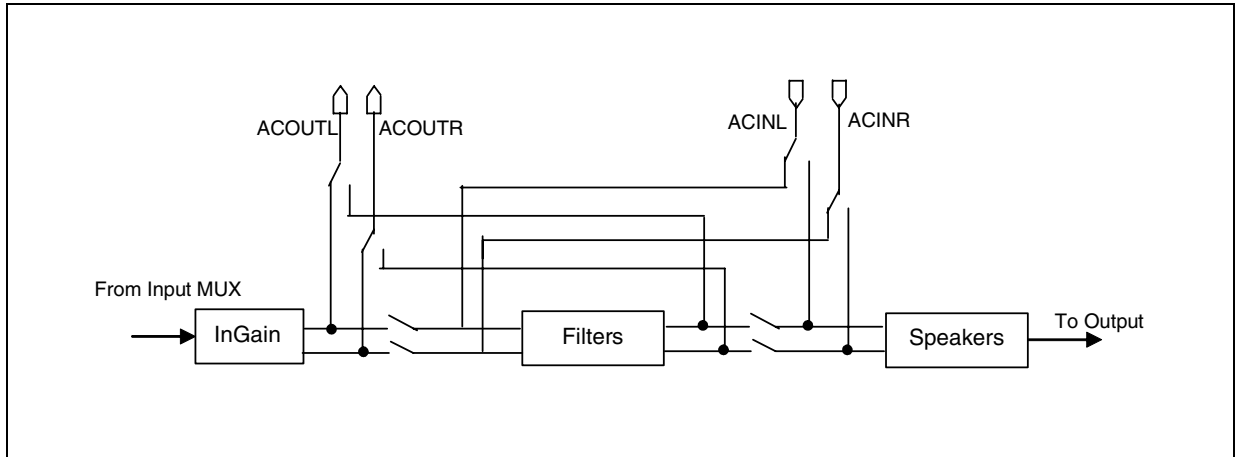

5.12 DSO Applications

For DSO applications, DSO filter is available for additional processing after the speaker control. It is a 2nd order Butterworth highpass filter with selectable flat mode. Figure 23 shows the diagram of the DSO that includes an external RC network.

Figure 23. DSO diagram

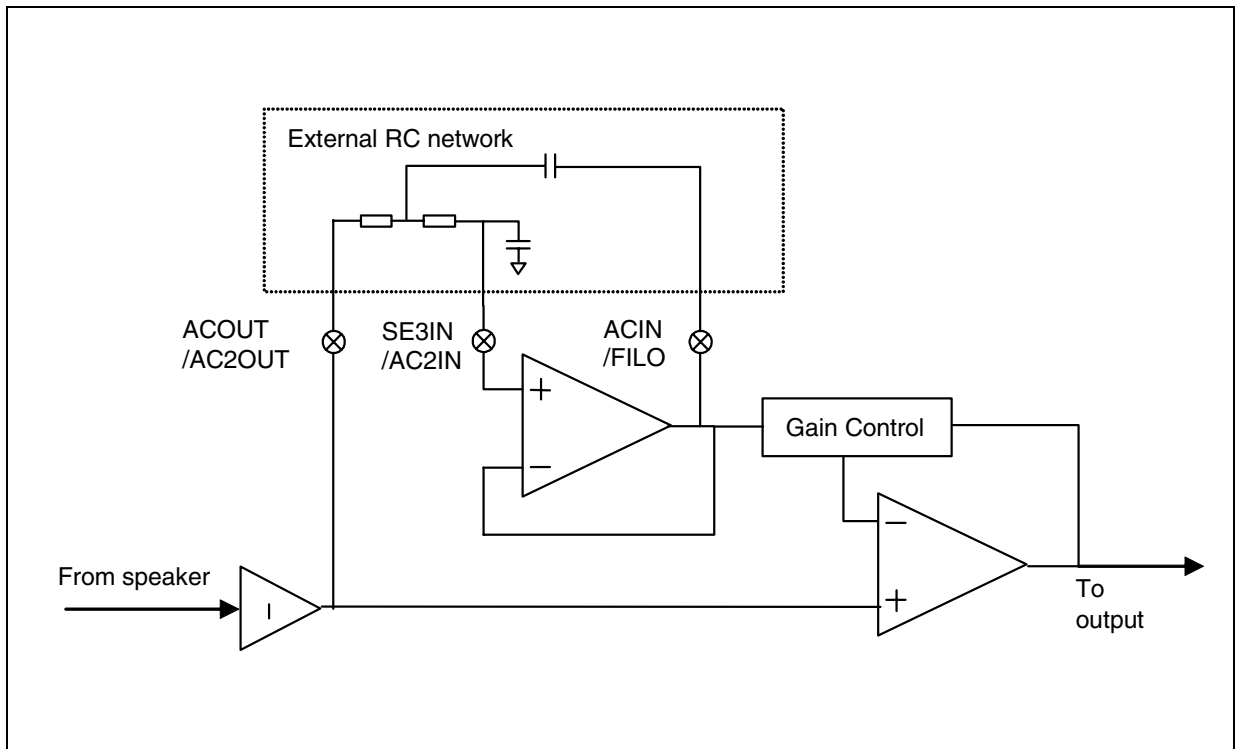

5.13 Output Selector and Mixing

The output-selector allows the front and rear speakers to connect to different sources. The setup of the output selector is shown in Figure 24. A Mixing-stage is placed after the front speaker-attenuator and can be set to mixing-mode. Having a full volume-attenuator for the mix-signal, the stage offers a wide flexibility to adapt the mixing levels.

Figure 24. Output Selector

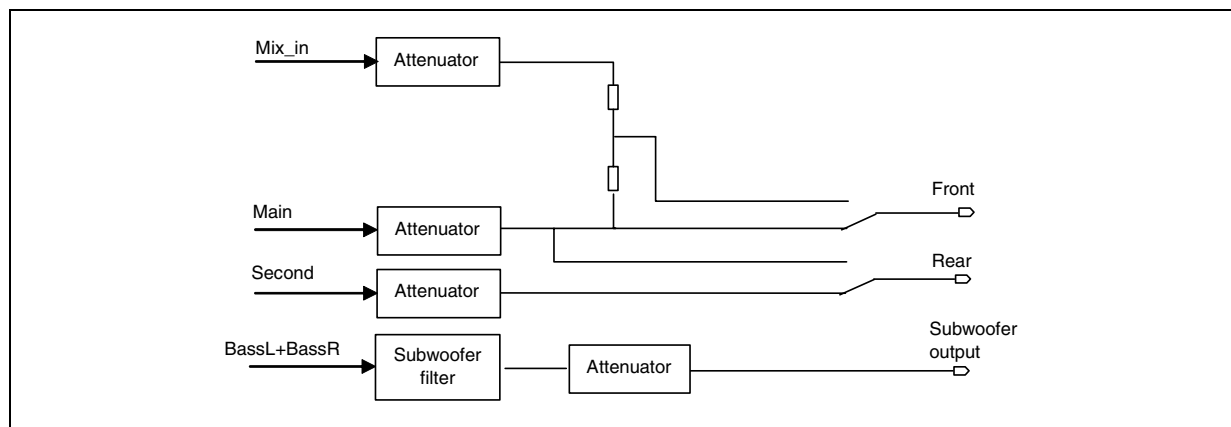

5.14 Audioprocessor Testing

In the test mode, which can be activated by setting bit D7 of the IIC subaddress byte and bit D0 of the testing audioprocessor byte, several internal signals are available at the SE1R pin. In this mode, the input resistance of 100kOhm is disconnected from the pin. Internal signals available for testing are listed in the data-byte specification.

5.15 Test Circuit

Figure 25. Test Circuit

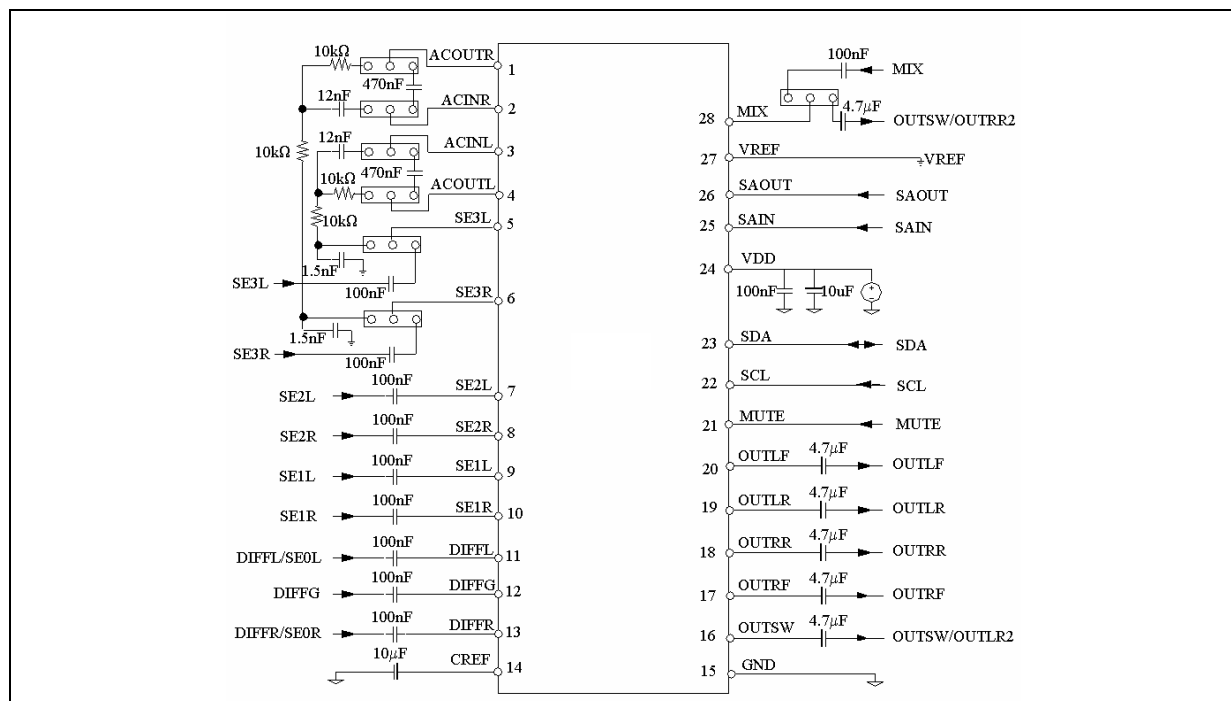

6 I²C BUS SPECIFICATION

6.1 Interface Protocol

The interface protocol comprises:

- a start condition (S)
- a chip address byte (the LSB determines read/write transmission)
- a subaddress byte
- a sequence of data (N-bytes + acknowledge)
- a stop condition (P)
- the max. clock speed is 500kbits/s
- 3.3V logic compatible

6.1.1 Receive Mode

S	1	0	0	0	1	0	0	R/W	ACK	TS	AZ	AI	A4	A3	A2	A1	A0	ACK	DATA	ACK	P
---	---	---	---	---	---	---	---	-----	-----	----	----	----	----	----	----	----	----	-----	------	-----	---

S = Start

R/W = "0" -> Receive Mode (Chip can be programmed by μ P)

"1" -> Transmission Mode (Data could be received by μ P)

ACK = Acknowledge

P = Stop

TS = Testing mode

AZ = Auto zero remain

AI = Auto increment

6.1.2 Transmission Mode

S	1	0	0	0	1	0	0	R/W	ACK	X	X	X	X	X	X	X	X	SM	ACK	P
---	---	---	---	---	---	---	---	-----	-----	---	---	---	---	---	---	---	---	----	-----	---

SM = Soft mute activated for main channel

X = Not Used

The transmitted data is automatic updated after each ACK. Transmission can be repeated without new chip address.

6.1.3 Reset Condition

A Power-On-Reset is invoked if the Supply-Voltage is below than 3.5V. After that the following data is written automatically into the registers of all subaddresses:

MSB							LSB
1	1	1	1	1	1	1	0

6.2 Subaddress (receive mode)

Table 7. Subaddress (receive mode)

MSB			LSB					FUNCTION
I2	I1	I0	A4	A3	A2	A1	A0	
0 1								Testing Mode Off On
	0 1							Auto Zero Remain Off On
		0 1						Auto Increment Mode Off On
			0	0	0	0	0	Main Source Selector
			0	0	0	0	1	Main Loudness
			0	0	0	1	0	Soft Mute / Clock Generator
			0	0	0	1	1	Volume
			0	0	1	0	0	Treble
			0	0	1	0	1	Middle
			0	0	1	1	0	Bass
			0	0	1	1	1	Second Source Selector
			0	1	0	0	0	Subwoofer / Middle / Bass
			0	1	0	0	1	Mixing / Gain Effect
			0	1	0	1	0	Speaker Attenuator Left Front
			0	1	0	1	1	Speaker Attenuator Right Front
			0	1	1	0	0	Speaker Attenuator Left Rear
			0	1	1	0	1	Speaker Attenuator Right Rear
			0	1	1	1	0	Mixing Level Control
			0	1	1	1	1	Subwoofer Attenuator
			1	0	0	0	0	Spectrum Analyzer / Clock Source / AC Mode
			1	0	0	0	1	Testing Audio Processor

6.3 Data Byte Specification

Table 8. Main Selector (0)

MSB							LSB	FUNCTION
D7	D6	D5	D4	D3	D2	D1	D0	
					0 0 0 0 1 1 1	0 0 1 1 0 0 1	0 1 0 1 0 1 x	Source Selector QD/SE: QD SE1 SE2 SE3 QD/SE: SE mute mute
	0 0 : 1 1	0 0 : 1 1	0 0 : 1 1	0 1 : 0 1				Input Gain 0dB 1dB : 14dB 15dB
0 1								Auto Zero on off

Table 9. Main Loudness (1)

MSB							LSB	FUNCTION
D7	D6	D5	D4	D3	D2	D1	D0	
				0 0 : 1 1	0 0 : 1 1	0 0 : 1 1	0 1 : 0 1	Attenuation 0dB -1dB : -14dB -15dB
		0 0 1 1	0 1 0 1					Center Frequency Flat 400Hz 800Hz 2400Hz
	0 1							High Boost on off
0 1								Loudness Soft Step on off

Table 10. Soft Mute / Clock Generator (2)

MSB							LSB	FUNCTION
D7	D6	D5	D4	D3	D2	D1	D0	
							0 1	Soft Mute on off
						0 1		Pin Influence for Mute Pin and IIC IIC
				0 0 1	0 1 x			Soft Mute Time 0.48ms 0.96ms 123ms
	0 0 0 0 1 1 1 1	0 0 1 1 0 0 1 1	0 1 0 1 1 0 1					Soft Step Time 0.160ms 0.321ms 0.642ms 1.28ms 2.56ms 5.12ms 10.24ms 20.48ms
0 1								Clock Fast Mode on off

Table 11. Volume / Speaker / Mixing / Subwoofer Attenuation (3, 10-15)

MSB							LSB	FUNCTION
D7	D6	D5	D4	D3	D2	D1	D0	
	0 0 : 0 0 0 : 1 1 1	0 0 : 0 0 0 : 0 0 1	0 0 : 1 0 1 : 1 1 x	0 0 : 1 0 1 : 1 1 x	0 0 : 1 0 0 : 1 1 x	0 0 : 1 0 0 : 1 1 x	0 1 : 1 0 1 : 0 1 x	Gain/Attenuation +0dB +1dB : +15dB -0dB -1dB : -78dB -79dB mute
0 1								Soft Step on off

Table 12. Treble Filter (4)

MSB							LSB	FUNCTION
D7	D6	D5	D4	D3	D2	D1	D0	
			0	1	1	1	1	Gain/Attenuation -15dB
			0	1	1	1	0	-14dB
			:	:	:	:	:	:
			0	0	0	0	1	-1dB
			0	0	0	0	0	0dB
			1	0	0	0	0	0dB
			1	0	0	0	1	+1dB
			:	:	:	:	:	:
			1	1	1	1	0	+14dB
			1	1	1	1	1	+15dB
	0	0						Treble Center Frequency 10.0kHz
	0	1						12.5kHz
	1	0						15.0kHz
	1	1						17.5kHz
0								Reference Output Select External Vref (4V)
1								Internal Vref (3.3V)

Table 13. Middle Filter (5)

MSB							LSB	FUNCTION
D7	D6	D5	D4	D3	D2	D1	D0	
			0	1	1	1	1	Gain/Attenuation -15dB
			0	1	1	1	0	-14dB
			:	:	:	:	:	:
			0	0	0	0	1	-1dB
			0	0	0	0	0	0dB
			1	0	0	0	0	0dB
			1	0	0	0	1	+1dB
			:	:	:	:	:	:
			1	1	1	1	0	+14dB
			1	1	1	1	1	+15dB
	0	0						Middle Q Factor 0.5
	0	1						0.75
	1	0						1
	1	1						1.25
0								Middle Soft Step on
1								off

Table 14. Bass Filter (6)

MSB							LSB	FUNCTION
D7	D6	D5	D4	D3	D2	D1	D0	
			0	1	1	1	1	Gain/Attenuation -15dB
			0	1	1	1	0	-14dB
			:	:	:	:	:	:
			0	0	0	0	1	-1dB
			0	0	0	0	0	0dB
			1	0	0	0	0	0dB
			1	0	0	0	1	+1dB
			:	:	:	:	:	:
			1	1	1	1	0	+14dB
			1	1	1	1	1	+15dB
	0	0						Bass Q Factor 1.0
	0	1						1.25
	1	0						1.5
	1	1						2.0
0								Bass Soft Step on
1								off

Table 15. Second Source Selector (7)

MSB							LSB	FUNCTION
D7	D6	D5	D4	D3	D2	D1	D0	
					0	0	0	Source Selector QD/SE: QD
					0	0	1	SE1
					0	1	0	SE2
					0	1	1	SE3
					1	0	0	QD/SE: SE
					1	0	1	mute
					1	1	x	mute
	0	0	0	0				Input Gain 0dB
	0	0	0	1				1dB
	:	:	:	:				:
	1	1	1	0				14dB
	1	1	1	1				15dB
0								Rear Speaker Source main source
1								second source

Table 16. Subwoofer /Middle / Bass (8)

MSB							LSB		FUNCTION
D7	D6	D5	D4	D3	D2	D1	D0		
						0 0 1 1	0 1 0 1	Subwoofer Cut-off Frequency flat 80Hz 120Hz 160Hz	
				0 0 1 1	0 1 0 1			Middle Center Frequency 500Hz 1000Hz 1500Hz 2500Hz	
		0 0 1 1	0 1 0 1					Bass Center Frequency 60Hz 80Hz 100Hz 200Hz	
	0 1							Bass DC Mode on off	
0 1								Smoothing Filter on off (bypass)	

Table 17. Mixing / Gain Effect (9)

MSB							LSB		FUNCTION
D7	D6	D5	D4	D3	D2	D1	D0		
							0 1	Mixing to Left Front Speaker on off	
						0 1		Mixing to Right Front Speaker on off	
					0 1			Mixing Enable on off	
				0 1				Subwoofer Enable (OUTLR2 & OUTRR2) on off	
0 0 : 1 1 1 1 1	0 0 : 0 0 0 0 1	0 0 : 0 0 1 1 x	0 1 : 0 1 x x					Gain Effect for DSO Filter 4dB 6dB : 20dB 22dB 0dB 0dB	

Table 18. Spectrum Analyzer / Clock Source / AC Mode (16)

MSB							LSB	FUNCTION
D7	D6	D5	D4	D3	D2	D1	D0	
							0 1	Spectrum Analyzer Filter Q Factor 3.5 1.75
						0 1		Reset Mode IIC Auto
					0 1			Spectrum Analyzer Source Bass InGain
				0 1				Spectrum Analyzer Run on off
			0 1					Reset on off
		0 1						Clock Source internal external
0 0 1 1	0 1 0 1							Coupling Mode DC Coupling (without DSO) AC coupling after InGain DC Coupling (with DSO) AC coupling after Bass

Table 19. Testing Audio Processor (17)

MSB							LSB	FUNCTION
D7	D6	D5	D4	D3	D2	D1	D0	
							0 1	Audio Processor Testing Mode off on
		0 0 0 0 0 0 0 0 0 0 0 0 0 0 0 0 0 1 1 1 1 1 1 1 1 1	0 0 0 0 0 0 1 0 1 0 1 0 1 0 1 1 0 1 1 1 1 1 1 1 1 1	0 0 0 0 1 1 0 0 0 0 0 1 1 0 1 1 0 0 1 0 1 0 1 1 1 1	0 0 1 1 0 1 0 0 1 0 1 0 1 1 0 1 1 1 1 1 1 1 1 1 1 1 1	0 1 0 1 0 1 0 0 1 0 0 1 0 1 1 1 0 0 0 1 1 1 1 1 1 1 1 1		Test Multiplexer Left InGain Left InGain Left Loudness Left Loudness Left Volume Left Volume Left Treble Left Treble Left Middle SMCLK Left Bass VrefSCR VGB1.26 SSCLK Clock200 Mon Ref5V5 BPout<1> BPout<2> BPout<3> BPout<4> BPout<5> BPout<6> BPout<7>
x	x							Not used

Figure 26. SO-28 Mechanical Data & Package Dimensions

DIM.	mm			inch		
	MIN.	TYP.	MAX.	MIN.	TYP.	MAX.
A			2.65			0.104
a1	0.1		0.3	0.004		0.012
b	0.35		0.49	0.014		0.019
b1	0.23		0.32	0.009		0.013
C		0.5			0.020	
c1	45° (typ.)					
D	17.7		18.1	0.697		0.713
E	10		10.65	0.394		0.419
e		1.27			0.050	
e3		16.51			0.65	
F	7.4		7.6	0.291		0.299
L	0.4		1.27	0.016		0.050
S	8° (max.)					

OUTLINE AND MECHANICAL DATA



SO-28

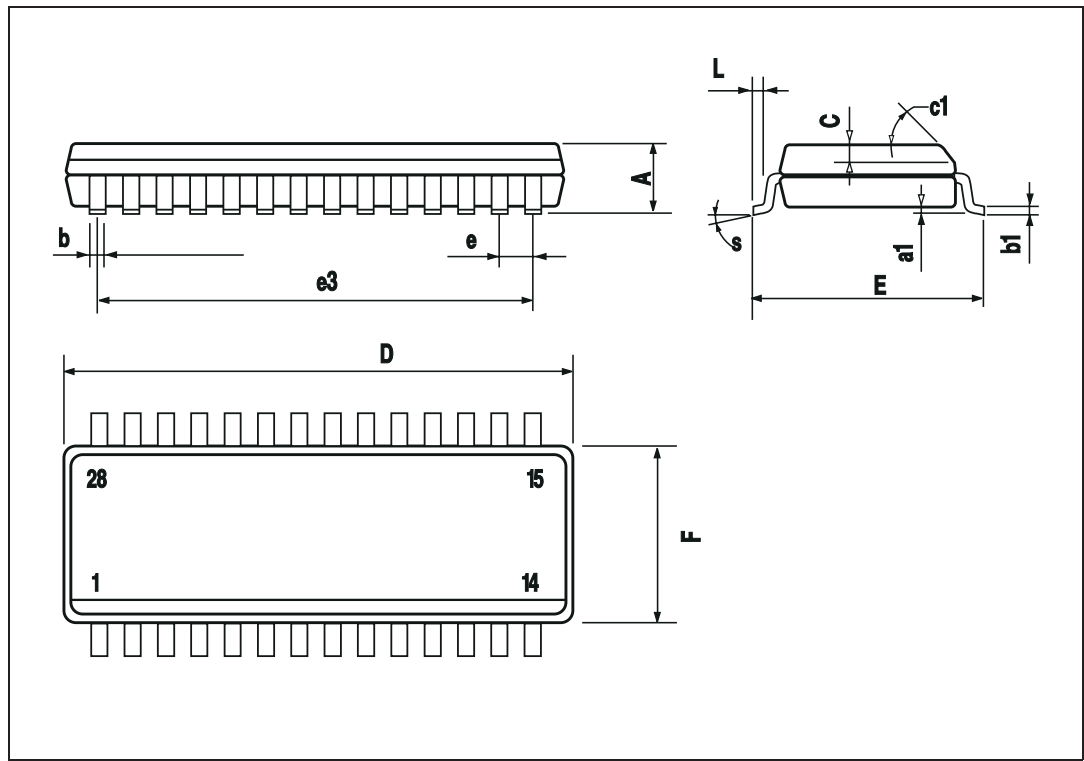

Table 20. Revision History

Date	Revision	Description of Changes
November 2004	1	First Issue
March 2005	2	Inserted new values in Electrical Characteristics

Information furnished is believed to be accurate and reliable. However, STMicroelectronics assumes no responsibility for the consequences of use of such information nor for any infringement of patents or other rights of third parties which may result from its use. No license is granted by implication or otherwise under any patent or patent rights of STMicroelectronics. Specifications mentioned in this publication are subject to change without notice. This publication supersedes and replaces all information previously supplied. STMicroelectronics products are not authorized for use as critical components in life support devices or systems without express written approval of STMicroelectronics.

The ST logo is a registered trademark of STMicroelectronics.
All other names are the property of their respective owners

© 2005 STMicroelectronics - All rights reserved

STMicroelectronics group of companies

Australia - Belgium - Brazil - Canada - China - Czech Republic - Finland - France - Germany - Hong Kong - India - Israel - Italy - Japan -
Malaysia - Malta - Morocco - Singapore - Spain - Sweden - Switzerland - United Kingdom - United States of America

www.st.com