

**2 x 30W DUAL BRIDGE CAR RADIO AMPLIFIER**

- **HIGH OUTPUT POWER CAPABILITY:**
  - 2 x 30W max./4Ω @ 13.2V, 1KHz
  - 2 x 22W typ./4Ω @ 14.4V, 1KHz, 10%
  - 2 x 19W typ./4Ω @ 13.2V, 1KHz, 10%
  - 2 x 28W typ./2Ω @ 14.4V, 1KHz, 10%
  - 2 x 25W typ./2Ω @ 13.2V, 1KHz, 10%
- **LOW DISTORTION**
- **LOW OUTPUT NOISE**
- **ST-BY FUNCTION**
- **MUTE FUNCTION**
- **AUTO-MUTE AT MIN. SUPPLY VOLTAGE DETECTION**
- **LOW EXTERNAL COMPONENT COUNT**
  - INTERNALLY FIXED GAIN (40dB)
  - NO EXTERNAL COMPENSATION
  - NO BOOTSTRAP CAPACITORS
- **ADDITIONAL MONO INPUT**

**PROTECTIONS:**

- **OUTPUT AC/DC SHORT CIRCUIT TO GND AND TO V<sub>S</sub>**
- **VERY INDUCTIVE LOADS**
- **OVERRATING CHIP TEMPERATURE WITH SOFT THERMAL LIMITER**
- **LOAD DUMP VOLTAGE**

**BLOCK DIAGRAM**

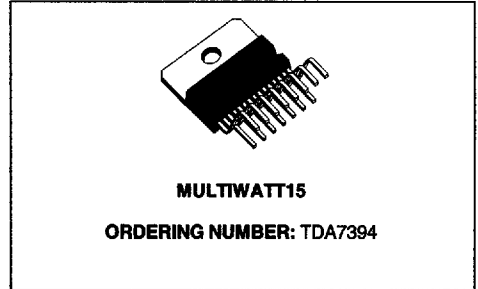
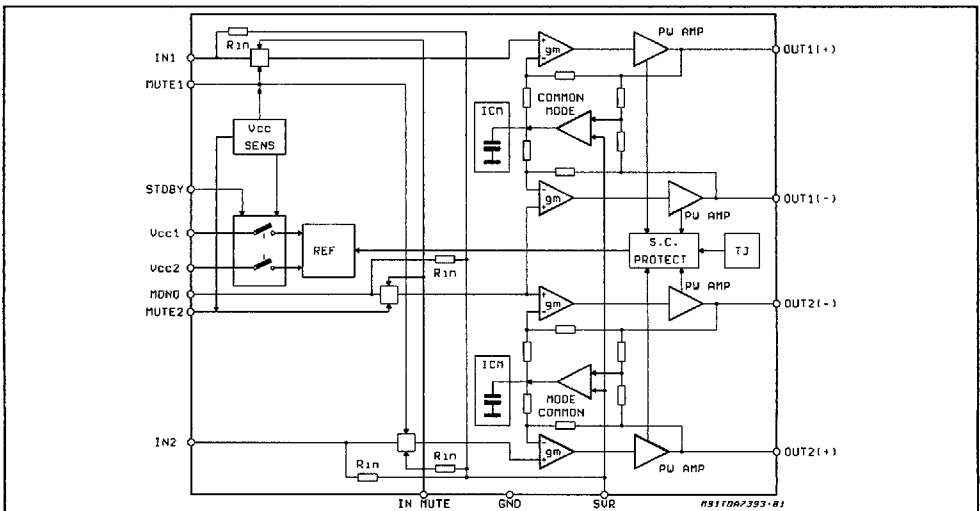

- **FORTUITOUS OPEN GND**
- **REVERSE BATTERY**
- **ESD PROTECTION**

**DESCRIPTION**

The TDA7394 is a new technology class AB Audio Power Amplifier in Multiwatt15 package designed for high end car radio applications. Thanks to the fully complementary PNP/NPN output configuration the high power performances of the TDA7394 are obtained without bootstrap capacitors. The extremely reduced components count allows very compact sets.

**ABSOLUTE MAXIMUM RATINGS**

Symbol	Parameter	Value	Unit
V <sub>CC</sub>	Operating Supply Voltage	18	V
V <sub>CC (DC)</sub>	DC Supply Voltage	28	V
V <sub>CC (pk)</sub>	Peak Supply Voltage (t = 50ms)	50	V
I <sub>o</sub>	Output Peak Current: Repetitive (Duty Cycle 10% at f = 10Hz) Non Repetitive (t = 100µs)	4.5 5.5	A A
P <sub>tot</sub>	Power dissipation, T <sub>case</sub> = 75°C (see derating curve)	50	W
T <sub>j</sub>	Junction Temperature	150	°C
T <sub>op</sub>	Operating Ambient Temperature	- 40 to 85	°C
T <sub>stg</sub>	Storage Temperature	- 55 to 150	°C

**PIN CONNECTION (Top view)**

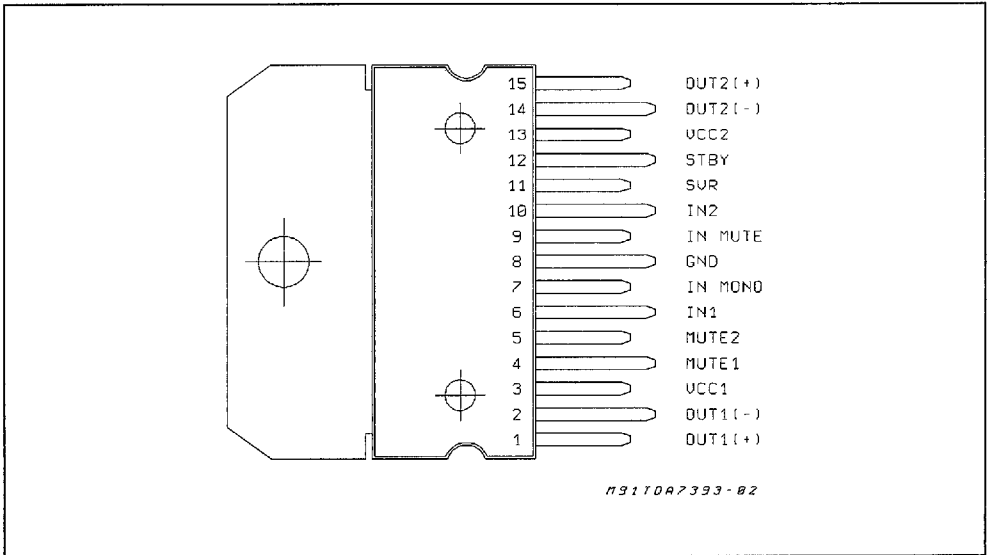

**THERMAL DATA**

Symbol	Parameter	Value	Unit
R <sub>th j-case</sub>	Thermal Resistance Junction to Case	Max. 1.5	°C/W

7929237 0064839 847

**ELECTRICAL CHARACTERISTICS** ( $V_S = 13.2V$ ;  $f = 1KHz$ ;  $R_g = 600\Omega$ ;  $R_L = 4\Omega$ ;  $T_{amb} = 25^\circ C$ ;  
Refer to the application circuit, unless otherwise specified.)

Symbol	Parameter	Test Condition	Min.	Typ.	Max.	Unit
$I_{q1}$	Quiescent Current			90	180	mA
$V_{OS}$	Output Offset Voltage		-200		+200	mV
$G_v$	Voltage Gain		38.5	40	41.5	dB
$P_o$	Output Power	THD = 10%; $V_S = 14.4V$ THD = 10% THD = 1% THD = 10%; $R_L = 2\Omega$ THD = 10%; $V_S = 14.4V$ ; $R_L = 2\Omega$	17	22 19 16 25 28		W W W W W
$P_{o,max}$	Max. Output Power	EIAJ RULES		30		W
THD	Distortion	$P_o = 4W$		0.08	0.3	%
$e_{No}$	Output Noise	$Bw = 20Hz$ to $20KHz$			0.5	mVrms
SVR	Supply Voltage Rejection	$f = 100Hz$ (stereo)		60		dB
$f_L$	Low Cut-Off Frequency			10		Hz
$f_H$	High Cut-Off Frequency			200		KHz
$R_i$	Input Impedance		10	15	20	K $\Omega$
$C_T$	Cross Talk	$f = 1KHz$	50	65		dB
$I_{SB}$	St-By Current Consumption				100	$\mu A$
$V_{SB,out}$	St-By OUT Threshold Voltage	Amp: ON	3.5			V
$V_{SB,IN}$	St-By IN Threshold Voltage	Amp: OFF			1.5	V
$V_{SB}$	Supply Dependent St-By Threshold	St-By = H, $V_S$ reducing/increasing		7.5	8.3	V
$A_M$	Mute Attenuation	$V_O = 1Vrms$		75		dB
$V_{M,out}$	Mute OUT Threshold Voltage	Amp: Play	3.5			V
$V_{M,IN}$	Mute IN Threshold Voltage	Amp: Mute			1.5	V
$V_M$	Supply Dependent Mute Threshold	Mute = IN, $V_S$ reducing/increasing		8.5	9.3	V
$I_m(L)$	Muting Pin Current	$V_{MUTE} = 1.5V$ (Source Current)	6	10	14	$\mu A$
$I_m(H)$	Muting Pin Current	$V_{MUTE} = 3.5V$ (Source Current)	6	10	14	$\mu A$

**Figure 1: Quiescent Current vs. Supply Voltage**

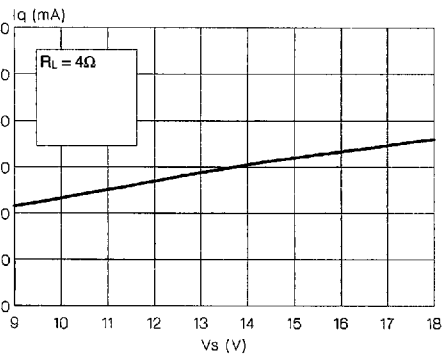

**Figure 2: Output Power vs. Supply Voltage**

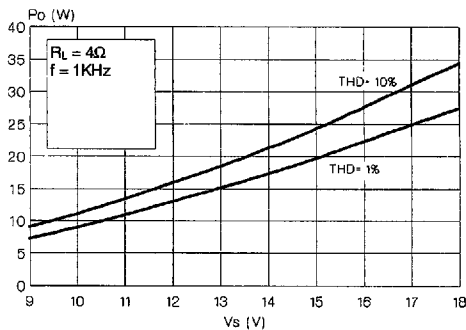

7226237 006440 569

Figure 3: Output Power vs Supply Voltage

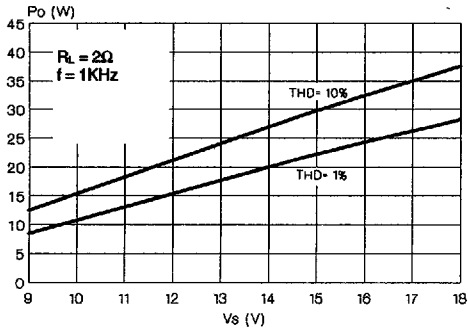

Figure 4: EIAJ Power vs. Supply Voltage

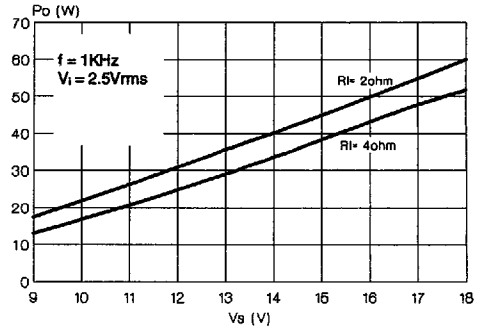

Figure 5: Cross-Talk vs. Frequency

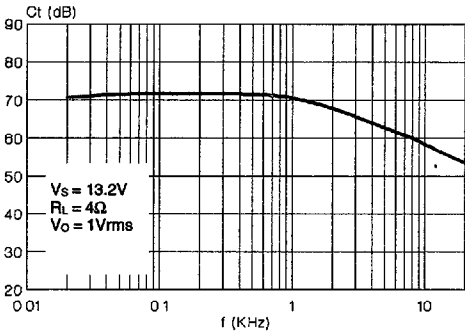

Figure 6: SVR vs. Frequency

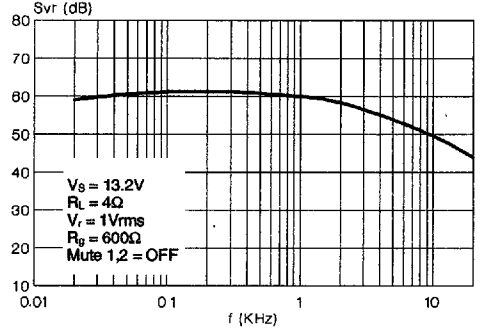

Figure 7: Distortion vs. Frequency

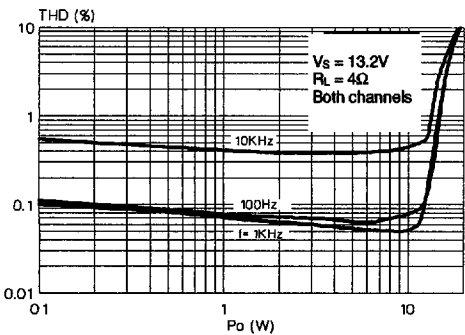
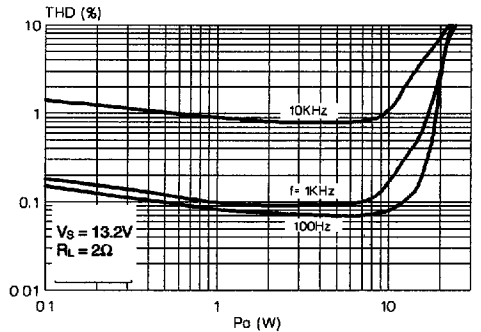

Figure 8: Distortion vs. Frequency



7929237 006484] 4T5

Figure 9: Block Diagram of Mute Circuit

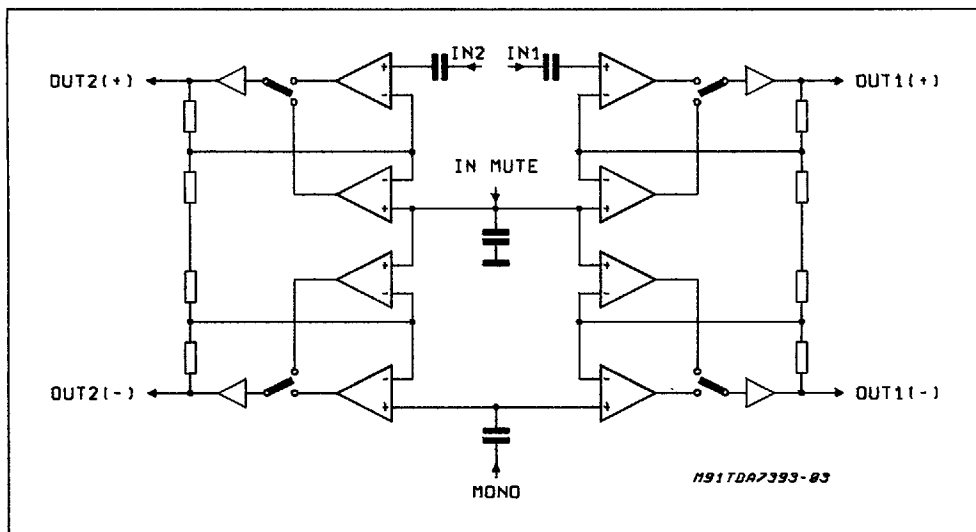
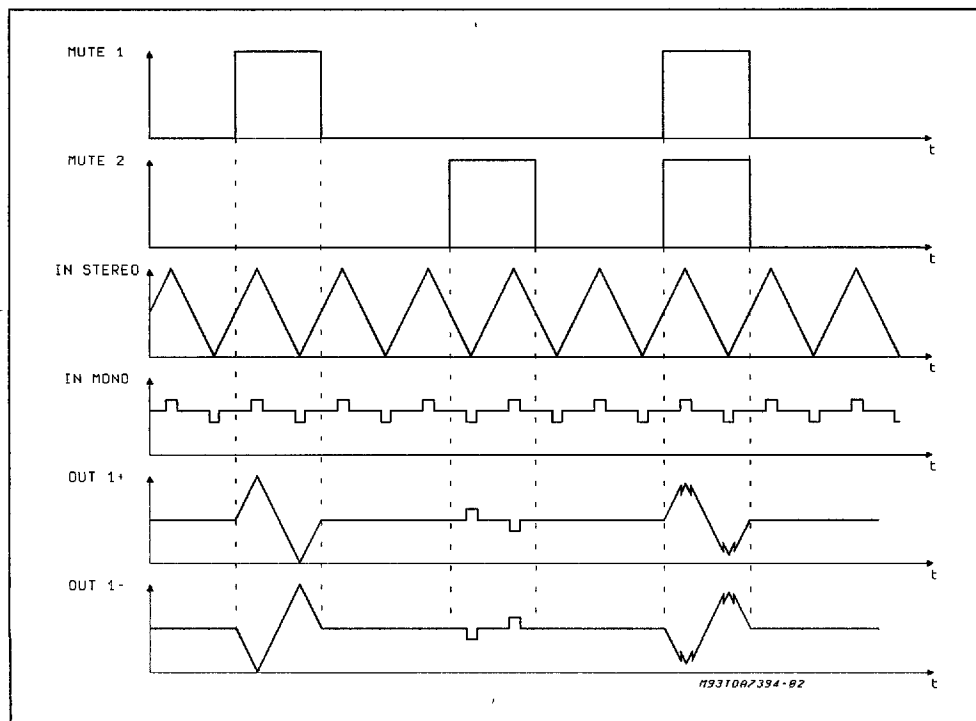

Figure 10: Explanatory Waveforms Of Mute Circuit



TEE 2484900 2E26262

Figure 11: Application Circuit

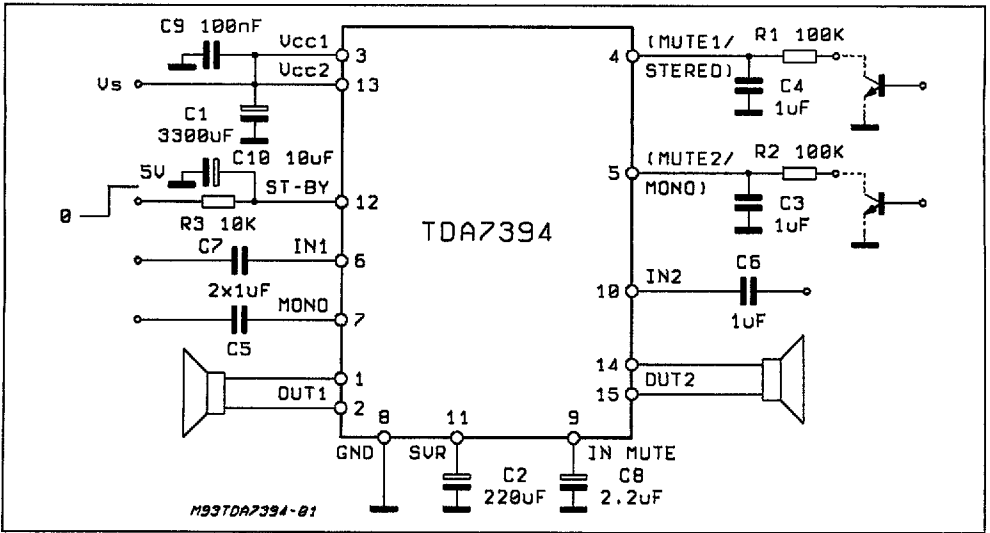
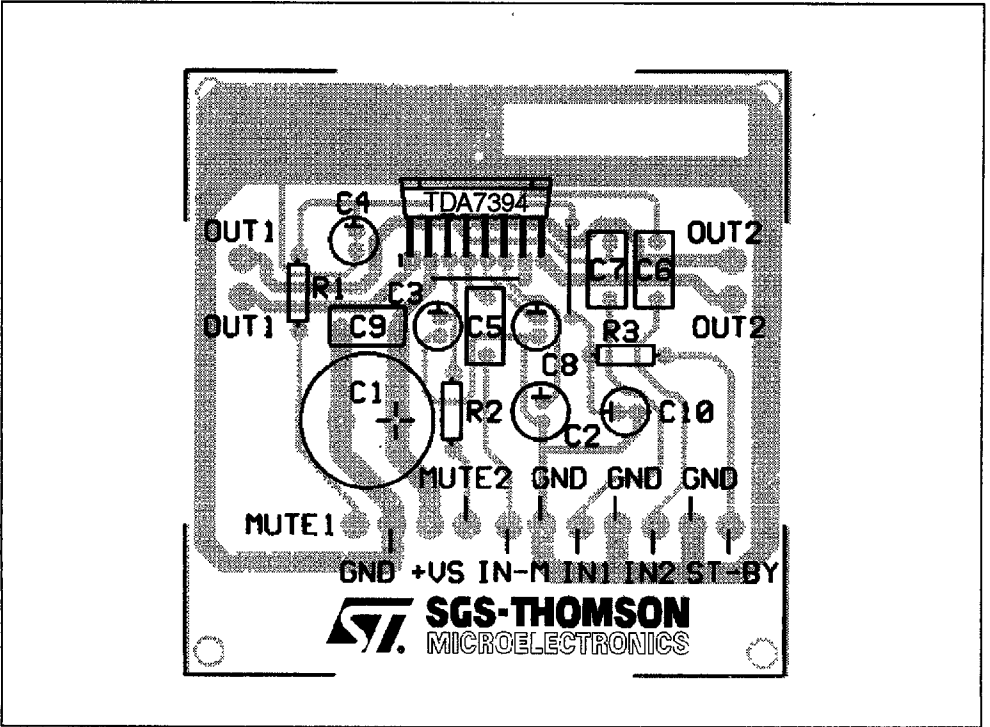

Figure 12: P.C. Board and Component Layout of the fig. 11 (1:1 scale)



7929237 0064843 278

Figure 13: Power Dissipation Derating Curve

