



TDA7376B

2 x 35W POWER AMPLIFIER FOR CAR RADIO

- HIGH OUTPUT POWER CAPABILITY:
 - 2 x 40W max./4Ω
 - 2 x 35W/4Ω EIAJ
 - 2 x 25W/4Ω @ 14.4V, 1KHz, 10%
- DIFFERENTIAL INPUTS
- MINIMUM EXTERNAL COMPONENT COUNT
- INTERNALLY FIXED GAIN (26dB)
- MUTE FUNCTION (CMOS COMPATIBLE)
- AUTOMUTE AT MINIMUM SUPPLY VOLTAGE DETECTION
- STAND-BY FUNCTION
- NO AUDIBLE POP DURING MUTE AND ST-BY OPERATIONS
- CLIPPING DETECTOR WITH PROGRAMMABLE DISTORTION THRESHOLD

PROTECTIONS:

- SHORT CIRCUIT (OUT TO GROUND, OUT TO SUPPLY VOLTAGE, ACROSS THE LOAD)
- OVERRATING CHIP TEMPERATURE WITH SOFT THERMAL LIMITER
- LOAD DUMP VOLTAGE
- FORTUITOUS OPEN GROUND
- LOUDSPEAKER DC CURRENT
- ESD

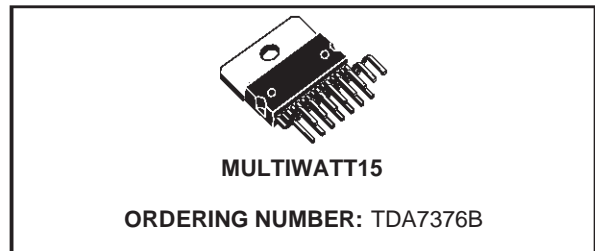

DESCRIPTION

The TDA7376B is a new technology dual bridge Audio Amplifier in Multiwatt 15 package designed for car radio applications. Thanks to the fully complementary PNP/NPN output stage configuration the TDA7376B delivers a rail-to-rail voltage swing with no need of bootstrap capacitors. Differential input pairs, that will accept either single ended or differential input signals, guarantee high noise immunity making the device suitable for both car radio and car boosters applications.

The audio mute control, that attenuates the output signal of the audio amplifiers, suppresses pop on - off transients and cuts any noises coming from previous stages. The St-By control, that debiases the amplifiers, reduces the cost of the power switch. The on-board programmable distortion detector allows compression facility whenever the ampifier is overdriven, so limiting the distortion at any levels inside the presettable range.

PIN CONNECTION (Continued)

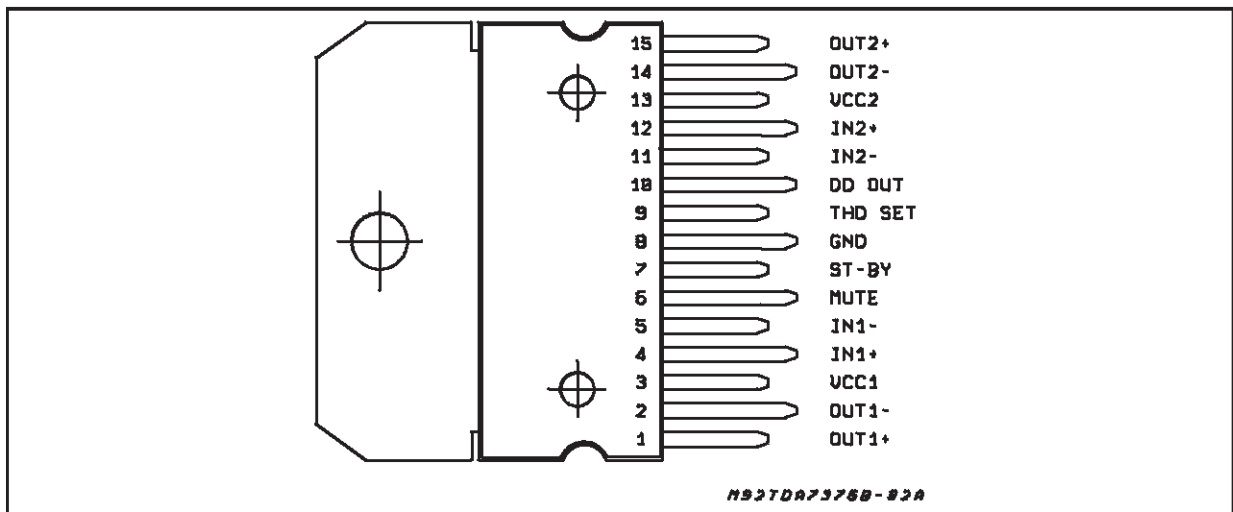

BLOCK DIAGRAM

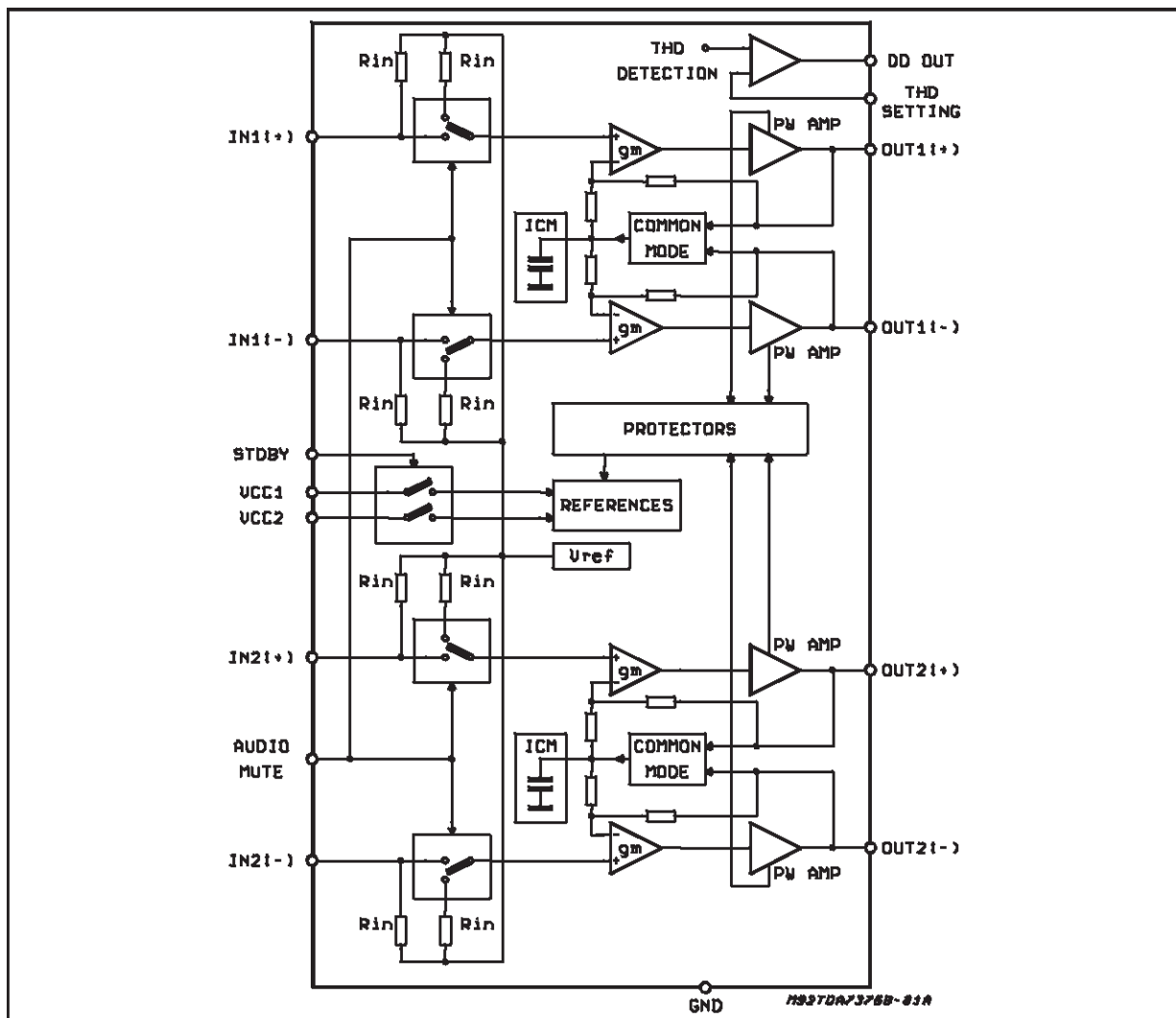

ABSOLUTE MAXIMUM RATINGS

Symbol	Parameter	Value	Unit
V_{OP}	Operating Supply Voltage	18	V
V_S	DC Supply Voltage	28	V
V_{peak}	Peak Supply Voltage ($t = 50ms$)	50	V
I_o	Output Peak Current (non rep. $t = 100\mu s$) Output Peak Current (rep. $f > 10Hz$)	4.5 3.5	A
P_{tot}	Power Dissipation at $T_{case} = 85^\circ C$	36	W
T_{stg}, T_j	Storage and Junction Temperature	-40 to 150	$^\circ C$

THERMAL DATA

Symbol	Parameter	Value	Unit
$R_{th\ j-case}$	Thermal Resistance Junction-case max.	1.8	$^\circ C/W$

Figure 1: Differential Inputs Test and Application Circuit

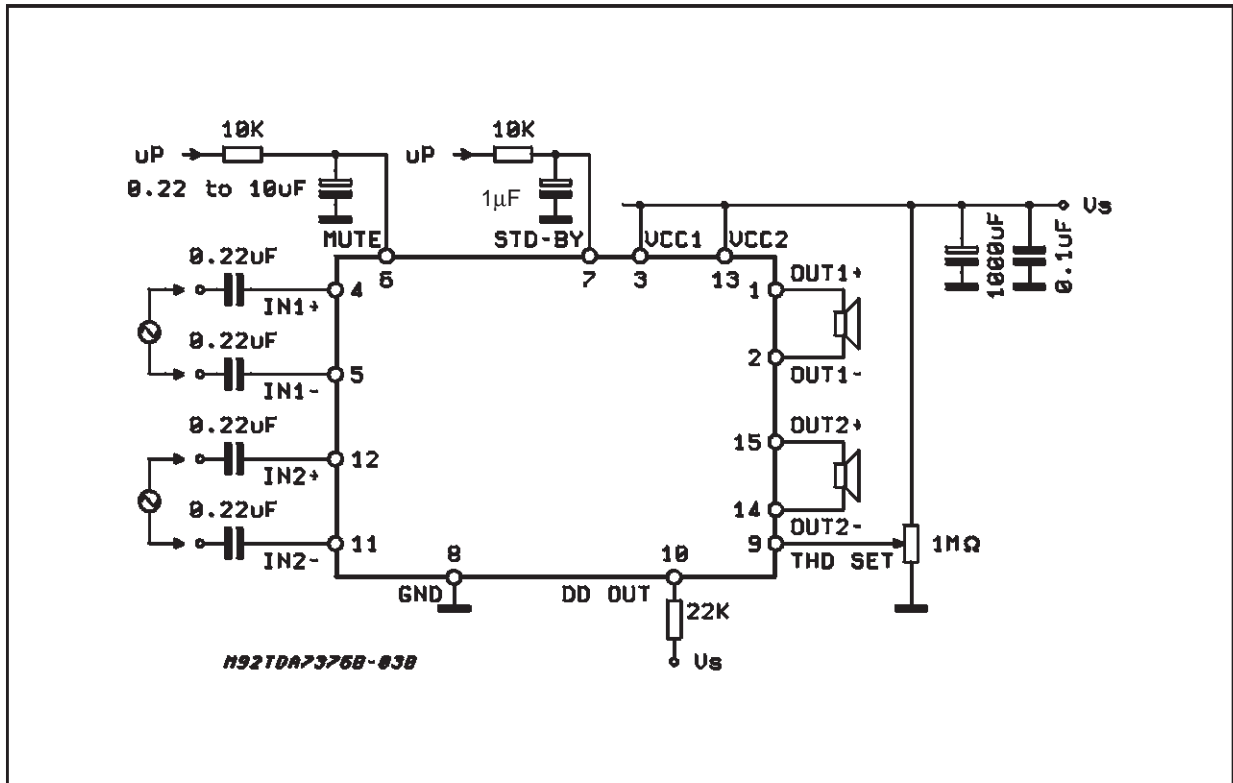
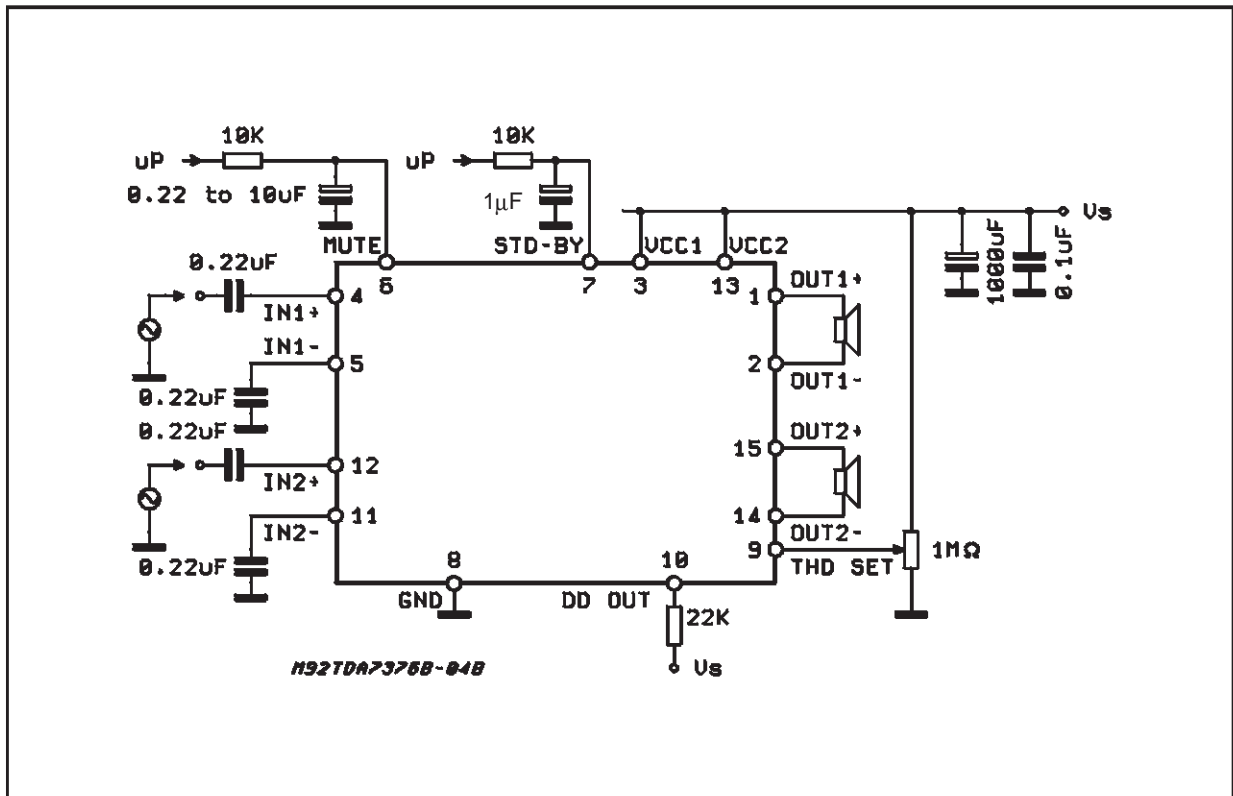

Figure 2: Single Ended Inputs Test and Application Circuit



TDA7376B

Figure 3: Application Board Reference Circuit

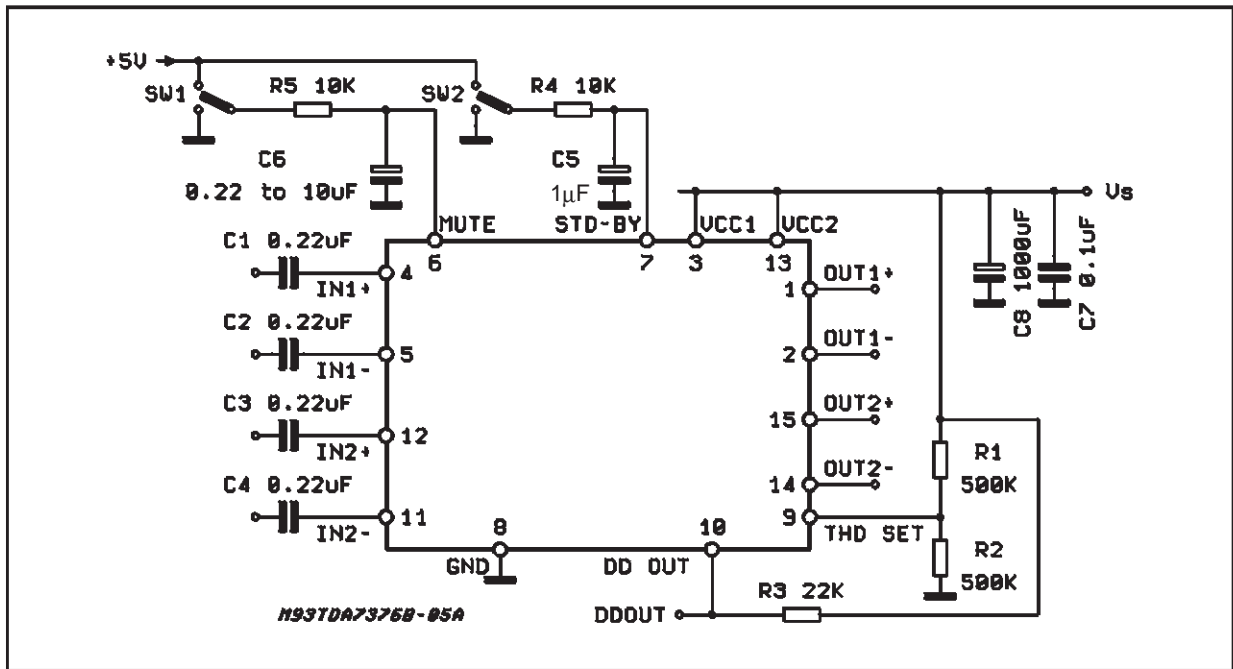
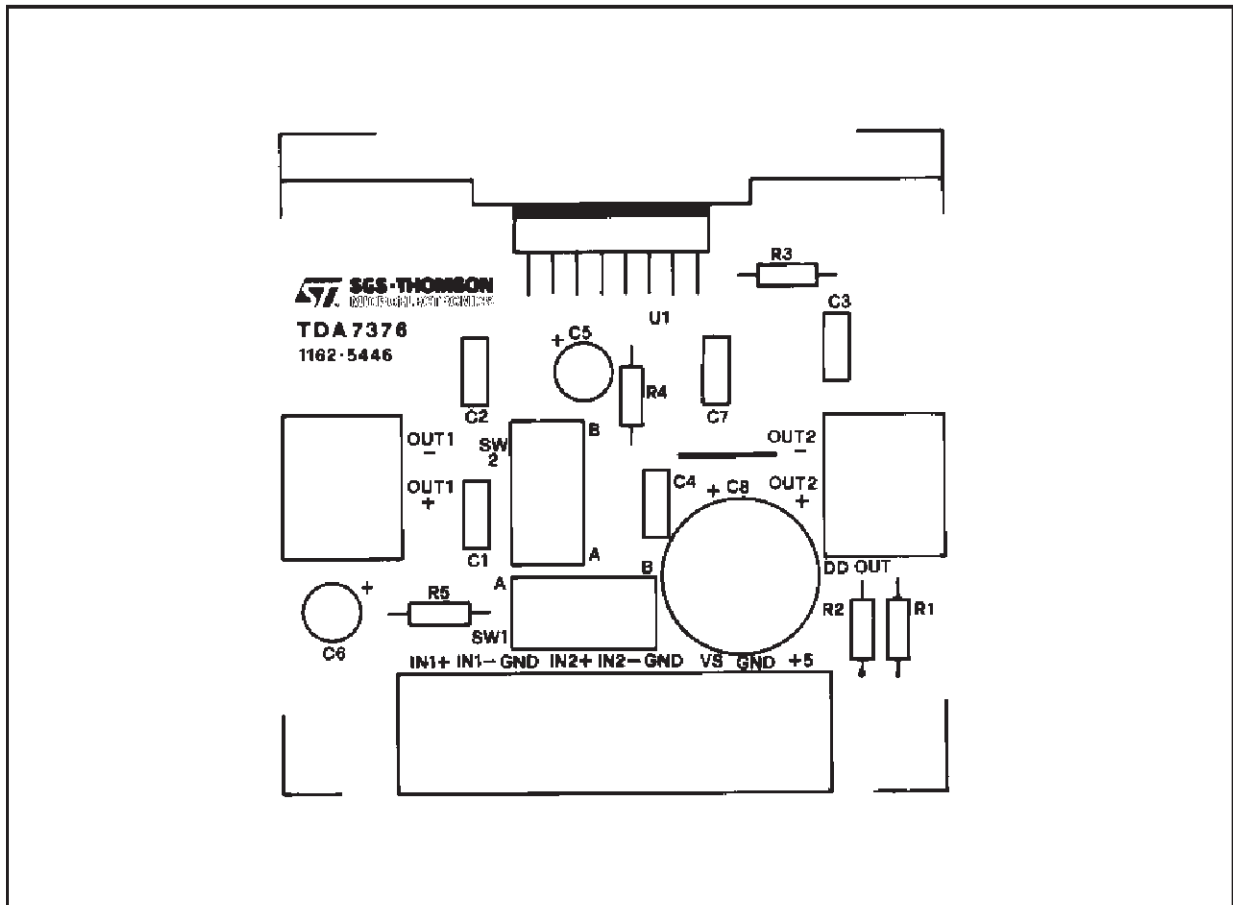

Figure 4: P.C. Board and Components Layout of the Circuit of Fig. 3 (1:1 scale)



ELECTRICAL CHARACTERISTICS (Refer to the test fig. 1 and 2 circuit, $T_{amb} = 25^{\circ}\text{C}$; $V_S = 14.4\text{V}$; $f = 1\text{KHz}$; $R_L = 4\Omega$; unless otherwise specified.)

Symbol	Parameter	Test Condition	Min.	Typ.	Max.	Unit
V_S	Supply Voltage		8		18	V
I_d	Total Quiescent Drain Current	$R_L = \infty$			200	mA
V_{OS}	Output Offset Voltage				120	mV
P_O	Output Power	THD = 10%	23	25		W
$P_{O\ max}$	Max. Output Power (*)	$V_S = 14.4\text{V}$	36	40		W
$P_{O\ EIAJ}$	EIAJ Output Power (*)	$V_S = 13.7\text{V}$	32	35		W
THD	Distortion	$P_O = 0.5$ to 10W		0.03	0.3	%
C_T	Cross Talk	$f = 1\text{KHz}$; $R_g = 0$ $f = 10\text{KHz}$; $R_g = 0$		80 70		dB dB
R_{IN}	Input Resistance	differential input single ended input	45 40			$K\Omega$ $K\Omega$
G_V	Voltage Gain	differential input single ended input	25 25	26 26	27 27	dB dB
ΔG_V	Channel Gain Balance				1	dB
E_N	Input Noise Voltage	$R_g = 600\Omega$; "A Weighted" $R_g = 600\Omega$; 22Hz to 22KHz		3 4	6	μV μV
SVR	Supply Voltage Rejection	$f = 100\text{Hz}$; $V_r = 1\text{Vrms}$; $R_g = 0$ $f = 10\text{KHz}$; $V_r = 1\text{Vrms}$; $R_g = 0$	45	55		dB dB
BW	Power Bandwidth	(-3dB)	75			KHz
CMRR	Common Mode Rejection Ratio	$V_{CM} = 1\text{Vrms}$ input referred	60			dB
A_{SB}	Stand-by Attenuation	$V_{SB} = 1.5\text{V}$; $P_{Oref} = 1\text{W}$	80	90		dB
$V_{sb\ IN}$	Stand-by in Threshold				1.5	V
$V_{sb\ OUT}$	Stand-by out Threshold		3.5			V
I_{sb}	Stand-by Current Consumption				100	μA
A_M	Mute Attenuation	$V_M = 1.5\text{V}$; $P_{Oref} = 1\text{W}$		85		dB
$V_{M\ IN}$	Mute in Threshold				1.5	V
$V_{M\ OUT}$	Mute out Threshold		3.5			V
I_6	Mute pin Current	$V_6 = 0$ to V_S ; ; $V_{S\ max.} = 18\text{V}$			100	μA
DDL	Distortion Detection Level (**)		3.5			%
D_{DOUT}	Distortion Detector Output DC Current	Output low, sinked current ($V_{pin10} = 1.5\text{V}$)	1			mA
		Output high, leakage current ($V_{pin10} = V_S$, @ $V_{S\ max} = 18\text{V}$)			10	μA

(*) Saturated square wave output

(**) see figure 5 for THD setting.

The TDA7376B is equipped with a programmable clipping distortion detector circuitry that allows to signal out the output stage saturation by providing a current sinking into an open collector output (DDout) when the total harmonic distortion of the output signal reaches the preset level. The desired threshold is fixed through an external divider that produces a proper voltage level across the

THD set pin. Fig. 5 shows the THD detection threshold versus the THD set voltage. Since it is essential that the THD set voltage be proportional to the supply voltage, fig. 5 shows its value as a fraction of V_{CC} . The actual voltage can be computed by multiplying the fraction corresponding to the desired THD threshold by the application's supply voltage.

Figure 5: Clip Detector Threshold vs. THD set. Voltage.

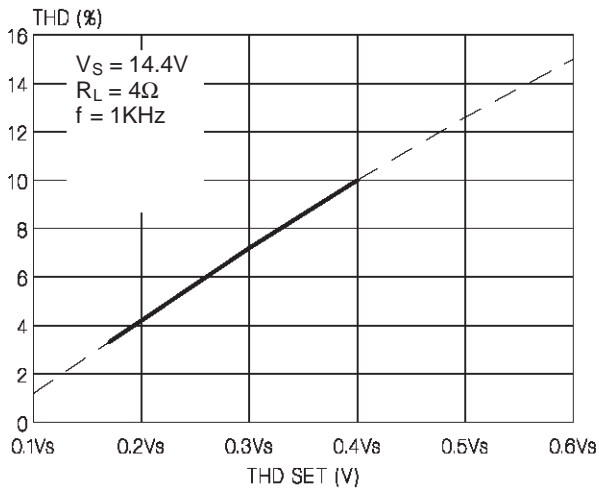

Figure 7: Quiescent Current vs. Temperature

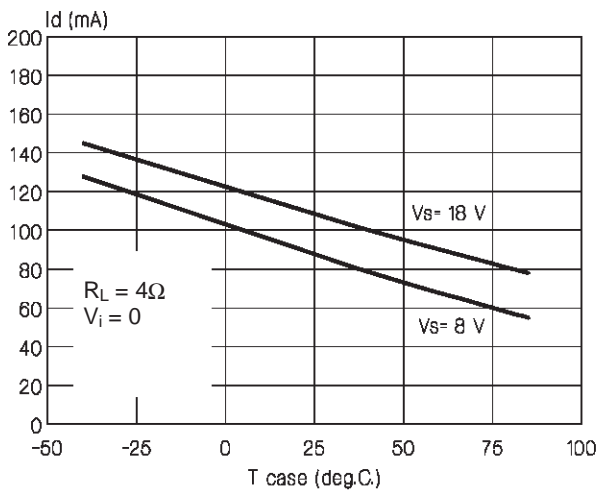

Figure 9: Ouput Power vs. Supply Voltage

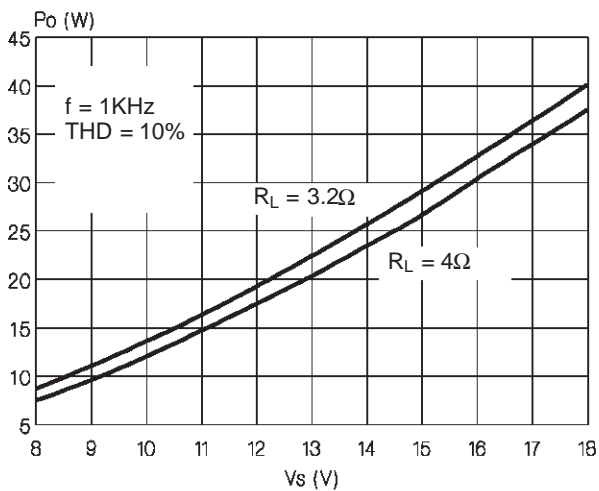

Figure 6: Quiescent Current vs. Supply Voltage

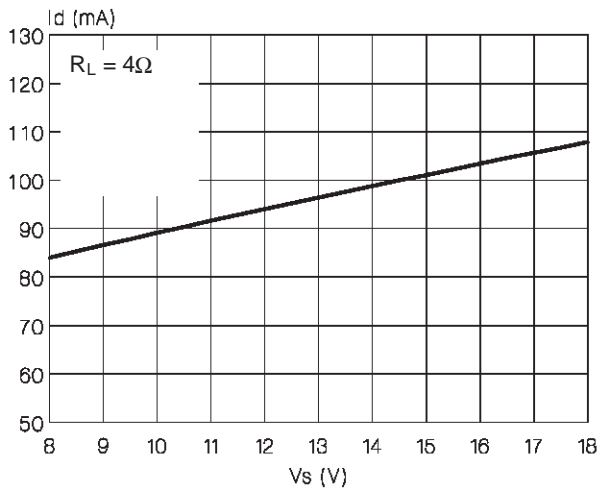

Figure 8: Ouput Power vs. Supply Voltage

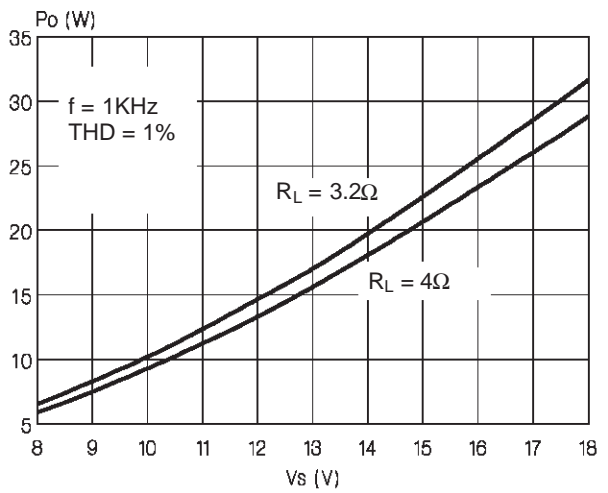

Figure 10: EIAJ Power vs. Supply Voltage

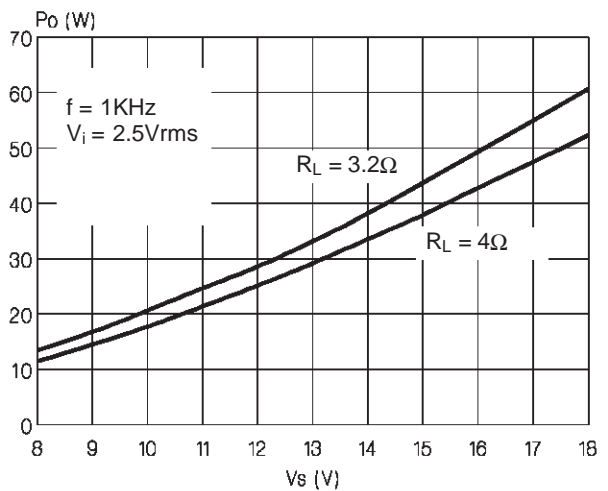

Figure 11: THD vs. Frequency

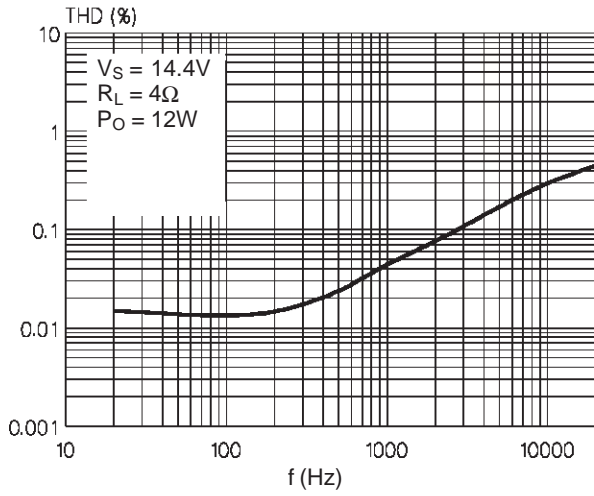

Figure 12: THD vs. Output Power

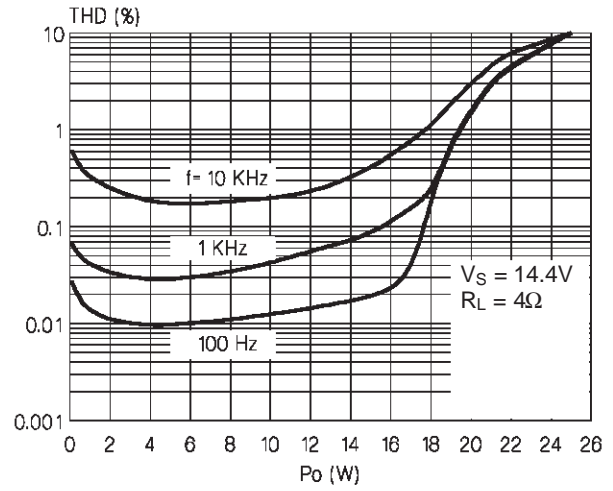

Figure 13: Dissipated Power & Efficiency vs. Output Power

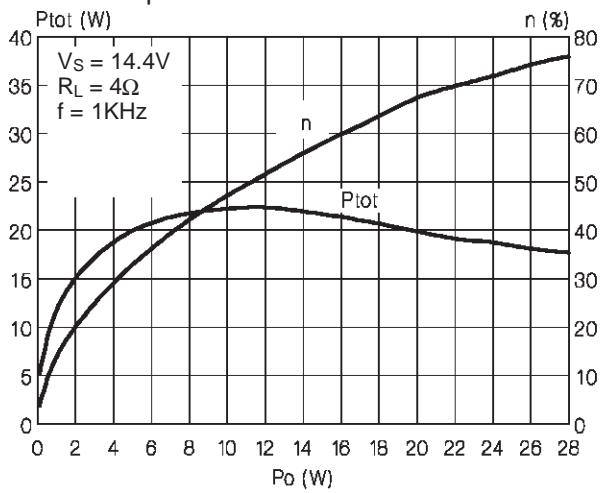

Figure 14: SVR vs. Frequency

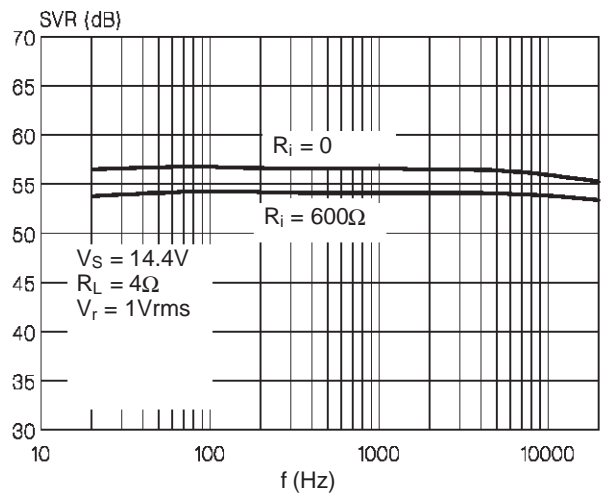

Figure 15: CMRR vs. Frequency

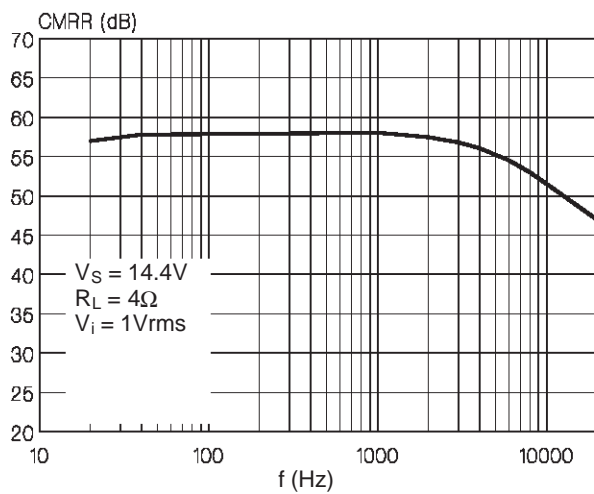
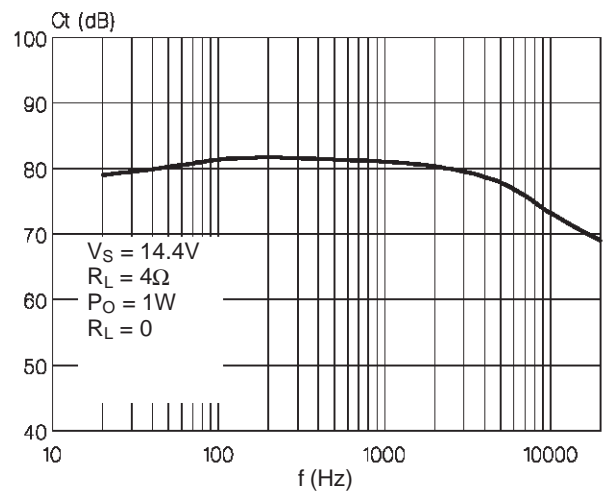

Figure 16: Crosstalk vs. Frequency



TDA7376B

DIM.	mm			inch		
	MIN.	TYP.	MAX.	MIN.	TYP.	MAX.
A			5			0.197
B			2.65			0.104
C			1.6			0.063
D		1			0.039	
E	0.49		0.55	0.019		0.022
F	0.66		0.75	0.026		0.030
G	1.02	1.27	1.52	0.040	0.050	0.060
G1	17.53	17.78	18.03	0.690	0.700	0.710
H1	19.6			0.772		
H2			20.2			0.795
L	21.9	22.2	22.5	0.862	0.874	0.886
L1	21.7	22.1	22.5	0.854	0.870	0.886
L2	17.65		18.1	0.695		0.713
L3	17.25	17.5	17.75	0.679	0.689	0.699
L4	10.3	10.7	10.9	0.406	0.421	0.429
L7	2.65		2.9	0.104		0.114
M	4.25	4.55	4.85	0.167	0.179	0.191
M1	4.63	5.08	5.53	0.182	0.200	0.218
S	1.9		2.6	0.075		0.102
S1	1.9		2.6	0.075		0.102
Dia1	3.65		3.85	0.144		0.152

OUTLINE AND MECHANICAL DATA

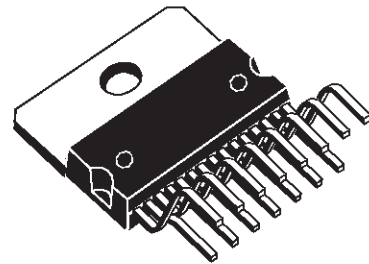

Multiwatt15 V

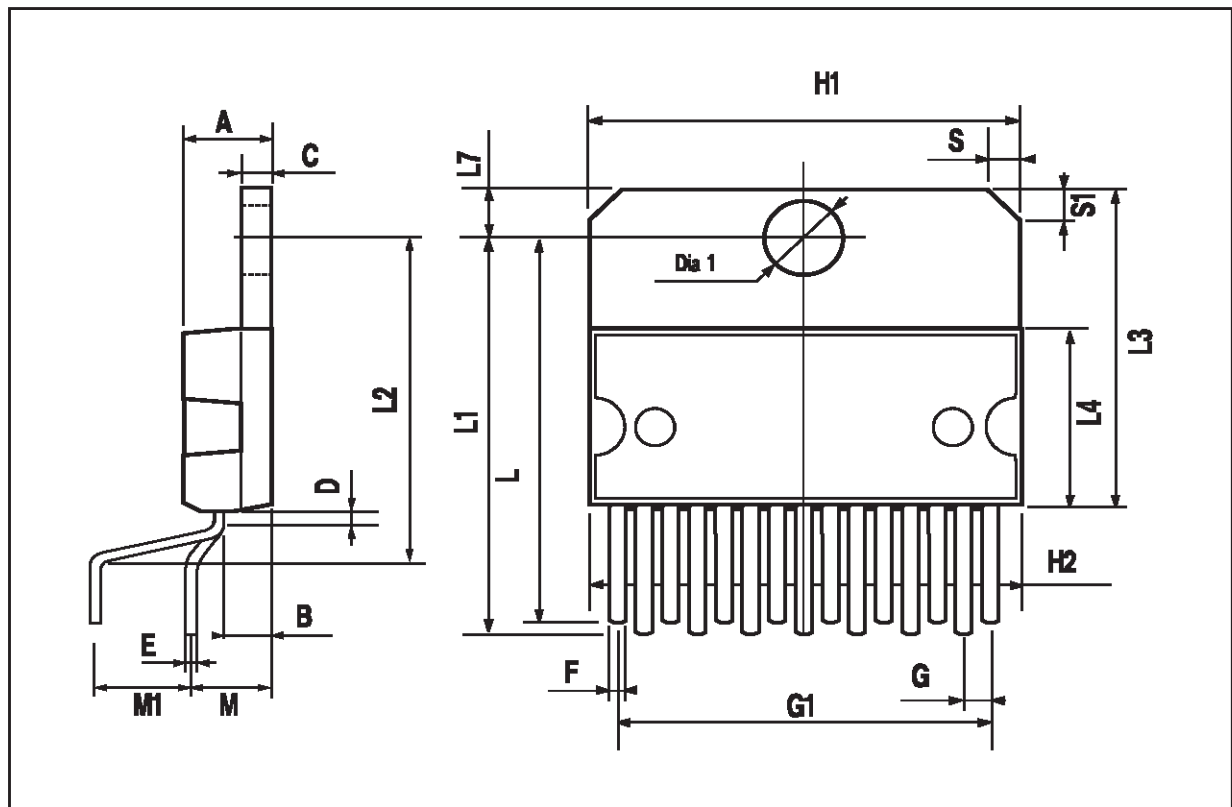

Information furnished is believed to be accurate and reliable. However, STMicroelectronics assumes no responsibility for the consequences of use of such information nor for any infringement of patents or other rights of third parties which may result from its use. No license is granted by implication or otherwise under any patent or patent rights of STMicroelectronics. Specification mentioned in this publication are subject to change without notice. This publication supersedes and replaces all information previously supplied. STMicroelectronics products are not authorized for use as critical components in life support devices or systems without express written approval of STMicroelectronics.

The ST logo is a registered trademark of STMicroelectronics

© 1998 STMicroelectronics – Printed in Italy – All Rights Reserved

STMicroelectronics GROUP OF COMPANIES

Australia - Brazil - Canada - China - France - Germany - Italy - Japan - Korea - Malaysia - Malta - Mexico - Morocco - The Netherlands - Singapore - Spain - Sweden - Switzerland - Taiwan - Thailand - United Kingdom - U.S.A.

<http://www.st.com>