



5W+5W DUAL BRIDGE AMPLIFIER

PRELIMINARY DATA

- WIDE SUPPLY VOLTAGE RANGE (3.5 - 12V)
- OUTPUT POWER
5+5W @THD = 10%, $R_L = 8\Omega$, $V_{CC} = 9.5V$
- SINGLE SUPPLY
- MINIMUM EXTERNAL COMPONENTS
 - NO SVR CAPACITOR
 - NO BOOTSTRAP
 - NO BOUCHEROT CELLS
 - INTERNALLY FIXED GAIN
- STAND-BY & MUTE FUNCTIONS
- SHORT CIRCUIT PROTECTION
- THERMAL OVERLOAD PROTECTION

TECHNOLOGY BI20II

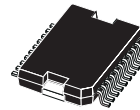

PowerSO20 Slug Down
ORDERING NUMBER: TDA7266D

DESCRIPTION

The TDA7266D is a dual bridge amplifier specially

designed for LCD TV/Monitor, PC Motherboard, TV and Portable Audio applications.

TEST AND APPLICATION CIRCUIT

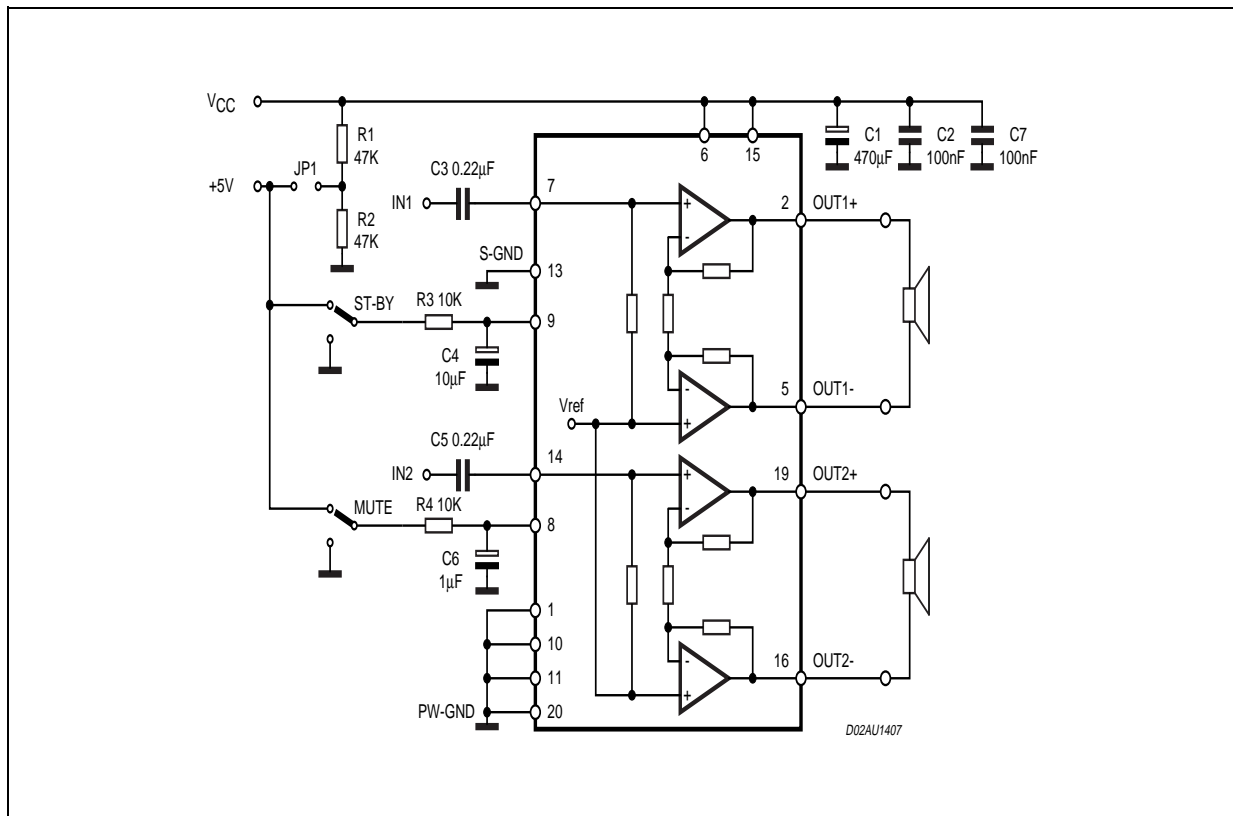

TDA7266D

ABSOLUTE MAXIMUM RATINGS

Symbol	Parameter	Value	Unit
V_s	Supply Voltage	20	V
I_o	Output Peak Current (internally limited)	1.5	A
P_{tot}	Total Power Dissipation ($T_{amb} = 70^\circ\text{C}$)	25	W
T_{op}	Operating Temperature	0 to 70	$^\circ\text{C}$
T_{stg}, T_j	Storage and Junction Temperature	-40 to 150	$^\circ\text{C}$

THERMAL DATA

Symbol	Parameter	Value	Unit
$R_{th\ j-case}$	Thermal Resistance Junction-case	2.1	$^\circ\text{C/W}$
$R_{th\ j-amb}$	Thermal Resistance Junction-ambient (on recommended PCB) note1	15	$^\circ\text{C/W}$

Notes: 1. See Application note AN668, available on WEB FR4 with 15 via holes and ground layer.

PIN CONNECTION

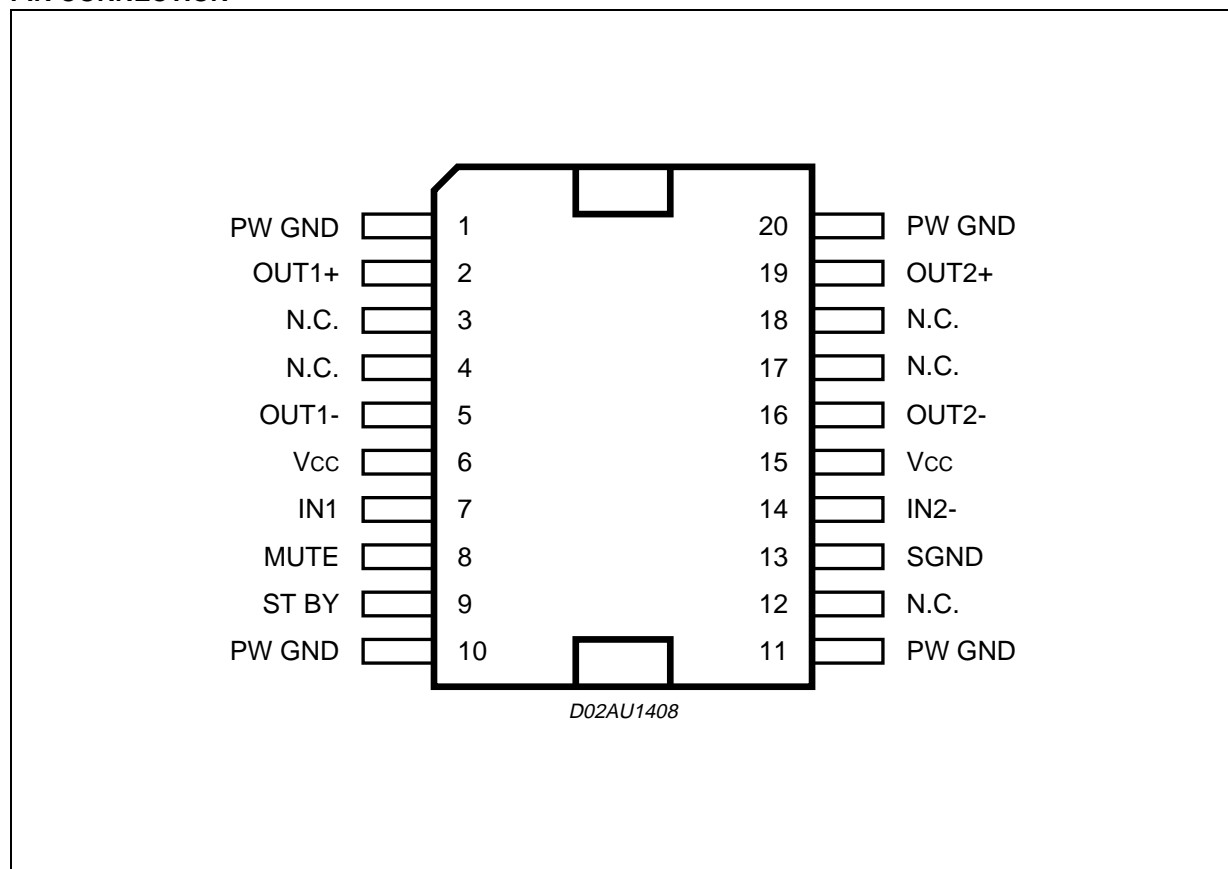

ELECTRICAL CHARACTERISTICS (Refer to test circuit) $V_{CC} = 9.5V$, $R_L = 8\Omega$, $f = 1KHz$, $T_{amb} = 25^\circ C$ unless otherwise specified)

Symbol	Parameter	Test Condition	Min.	Typ.	Max.	Unit
V_{CC}	Supply Range		3.5	9.5	12	V
I_q	Total Quiescent Current			50	60	mA
V_{OS}	Output Offset Voltage				120	mV
P_O	Output Power	THD 10%	4.3	5		W
THD	Total Harmonic Distortion	$P_O = 1W$		0.05	0.2	%
		$P_O = 0.1W$ to $2W$ $f = 100Hz$ to $15KHz$			1	%
SVR	Supply Voltage Rejection	$f = 100Hz$, $VR = 0.5V$	40	56		dB
CT	Crosstalk		46	60		dB
A_{MUTE}	Mute Attenuation		60	80		dB
T_w	Thermal Threshold			150		$^\circ C$
G_V	Closed Loop Voltage Gain		25	26	27	dB
ΔG_V	Voltage Gain Matching				0.5	dB
R_i	Input Resistance		25	30		K Ω
V_{TMUTE}	Mute Threshold	for $V_{CC} > 6.4V$; $V_o = -30dB$	2.3	2.9	4.1	V
		for $V_{CC} < 6.4V$; $V_o = -30dB$	$V_{CC}/2 - 1$	$V_{CC}/2 - 0.75$	$V_{CC}/2 - 0.5$	V
V_{TST-BY}	St-by Threshold		0.8	1.3	1.8	V
I_{ST-BY}	St-by Current $V_6 = GND$				100	μA
e_N	Total Output Voltage	A Curve		150		μV

APPLICATIVE SUGGESTIONS

STAND-BY AND MUTE FUNCTIONS

(A) Microprocessor Application

In order to avoid annoying "Pop-Noise" during Turn-On/Off transients, it is necessary to guarantee the right St-by and mute signals sequence. It is quite simple to obtain this function using a microprocessor (Fig. 1 and 2).

At first St-by signal (from μ P) goes high and the voltage across the St-by terminal (Pin 9) starts to increase exponentially. The external RC network is intended to turn-on slowly the biasing circuits of the amplifier, this to avoid "POP" and "CLICK" on the outputs.

When this voltage reaches the St-by threshold level, the amplifier is switched-on and the external capacitors in series to the input terminals (C1, C3) start to charge.

It's necessary to maintain the mute signal low until the capacitors are fully charged, this to avoid that the device goes in play mode causing a loud "Pop Noise" on the speakers.

A delay of 100-200ms between St-by and mute signals is suitable for a proper operation.

Figure 1. Microprocessor Application

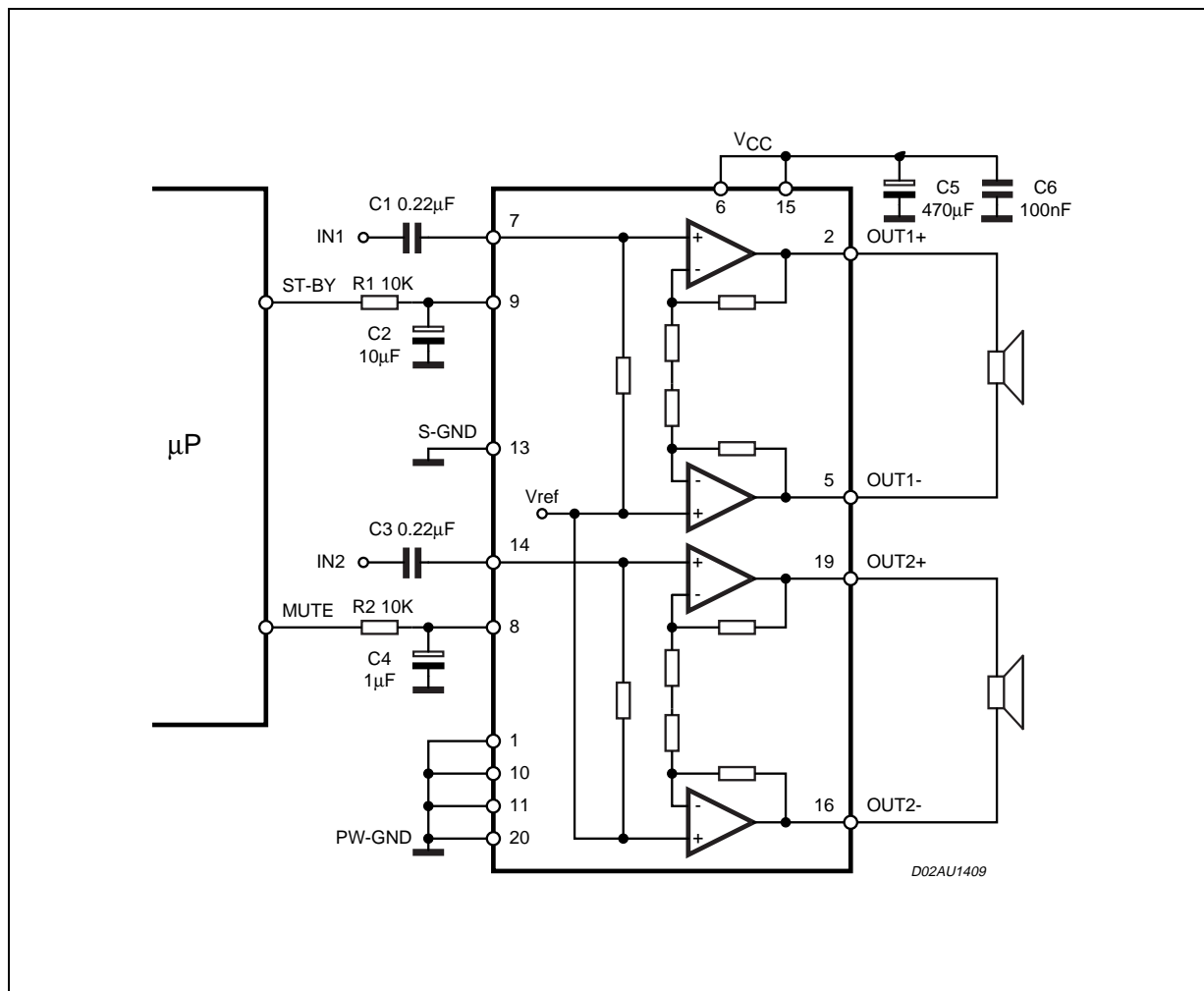
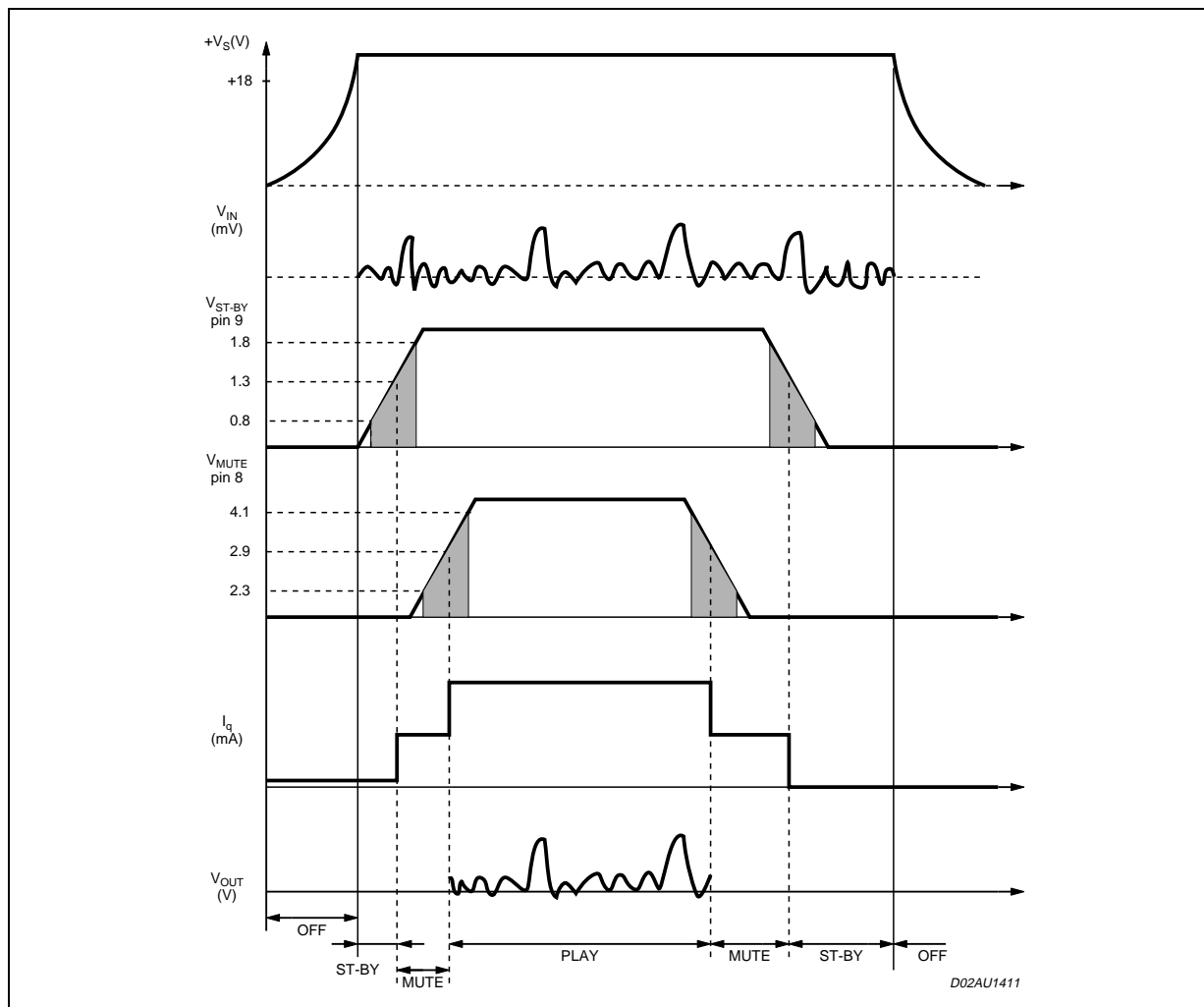

Figure 2. Microprocessor Driving Signals



B) Low Cost Application

In low cost applications where the mP is not present, the suggested circuit is shown in fig.3.

The St-by and mute terminals are tied together and they are connected to the supply line via an external voltage divider.

The device is switched-on/off from the supply line and the external capacitor C4 is intended to delay the St-by and mute threshold exceeding, avoiding "Popping" problems.

So to avoid any popping or clicking sound, it is important to clock:

- a **Correct Sequence:** At turn-ON, the Stand-by must be removed at first, then the Mute must be released after a delay of about 100-200ms. On the contrary at turn-OFF the Mute must be activated as first and then the Stand-by.

With the values suggested in the Application circuit the right operation is guaranteed.

- b **Correct Threshold Voltages:** In order to avoid that due to the spread in the internal thresholds (see the above limits) a wrong external voltage causes uncertain commutations for the two functions we suggest to use the following values:

Mute for $V_{CC} > 6.4V$: $V_T = 2.3V$
Mute for $V_{CC} < 6.4V$: $V_T = V_{CC}/2 - 1$
Stand-by	: $V_T = 0.8V$

Figure 3. Stand-alone low-cost Application

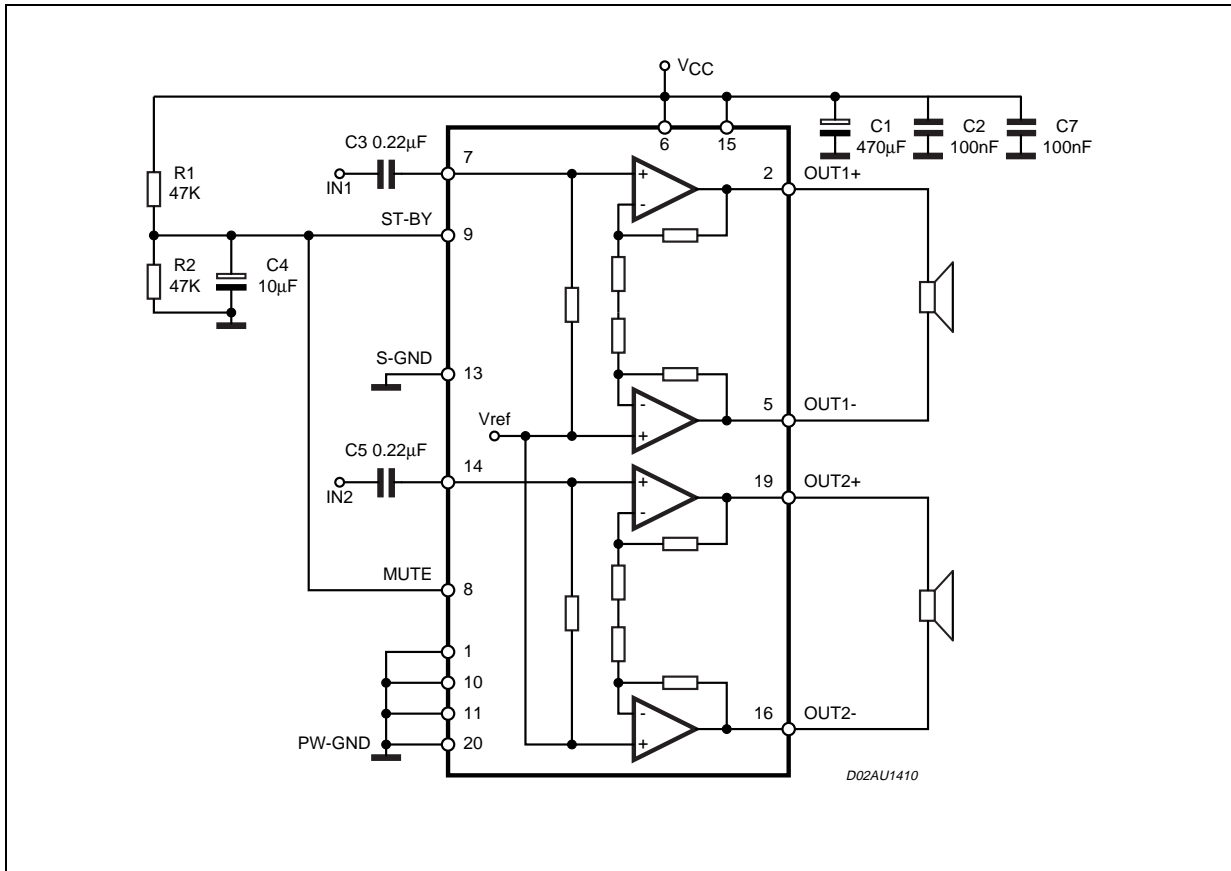

PCB Layout and External Components:

Regarding the PCB layout care must be taken for three main subjects:

- c) Signal and Power Gnd separation
- d) Dissipating Copper Area
- e) Filter Capacitors positioning

)Signal and Power Gnd separation:

c To the Signal GND must be referred the Audio Input Signals, the Mute and Stand-by Voltages and the device PIN.13. This Gnd path must be as clean as possible in order to improve the device THD+Noise and to avoid spurious oscillations across the speakers.

The Power GND is directly connected to the Output power Stage transistors (Emitters) and is crossed by large amount of current, this path is also used in this device to dissipate the heating generated (no needs of external heatsinker).

Referring to the typical application circuit, the separation between the two GND paths must be obtained connecting them separately (star routing) to the bulk Electrolytic capacitor C1 (470µF).

Regarding the Power Gnd dimensioning we have to consider the Dissipated Power the Thermal Protection Threshold and the Package thermal Characteristics.

d Dissipating Copper Area:

Dissipated Power:

The max dissipated power happens for a THD near 1% and is given by the formula:

$$P_{dmax(W)} = 2 \cdot \frac{V_{CC}^2}{\pi^2 \frac{RI}{2}} + I_q V_{CC}$$

This gives for: $V_{CC} = 9.5V$, $RI = 8\Omega$, $I_q = 50mA$ a dissipated power of $P_d = 5W$.

Thermal Protection:

The thermal protection threshold is placed at a junction temperature of $150^\circ C$.

Package Thermal Characteristics:

The thermal resistance Junction to Ambient obtainable with a GND copper Area of 3×3 cm and with 16 via holes (see picture) is about $15^\circ C/W$. This means that with the above mentioned max dissipated Power ($P_d=5W$) we can expect a $75^\circ C$, this gives a safety margin before the thermal protection intervention in the consumer environments where a $50^\circ C$ ambient is specified as maximum

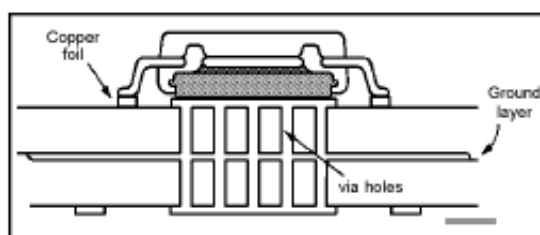

The Thermal constraints determine the max supply voltage that can be used for the different Load Impedances, this in order to avoid the thermal Protection Intervention.

The max. dissipated power must be not in excess of $5W$, this at turns gives the following operating supply voltages:

Load (Ohm)	Supply Voltage (V)
4	6.5
6	8.5
8	9.5
16	14

e Filter Capacitors Positioning:

The two Ceramic capacitors C2/C7 (100nF) must be placed as close as possible respectively to the two V_{CC} pins (6 - 15) in order to avoid the possibility of oscillations arising on the output Audio signals.

Package Informations:

You can find a complete description for the PowerSO package into the APPLICATION NOTE AN668 available on web.

Here we want to focalize the attention only on the the Dissipating elements and ground layer.

Figure 6. Distortion vs Frequency

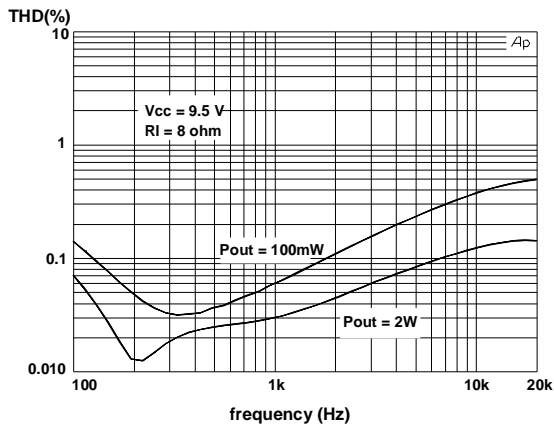

Figure 9. Stand-By attenuation vs Vpin 9

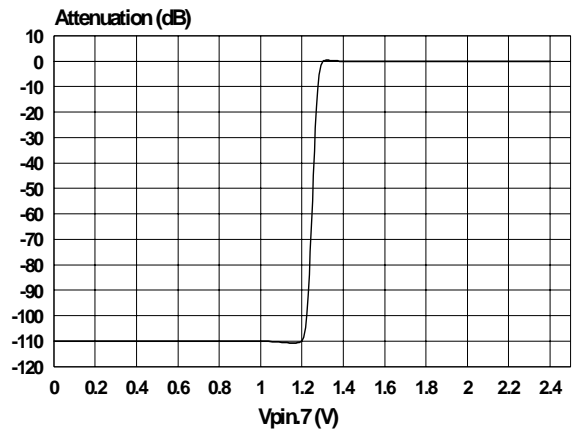

Figure 7. Gain vs Frequency

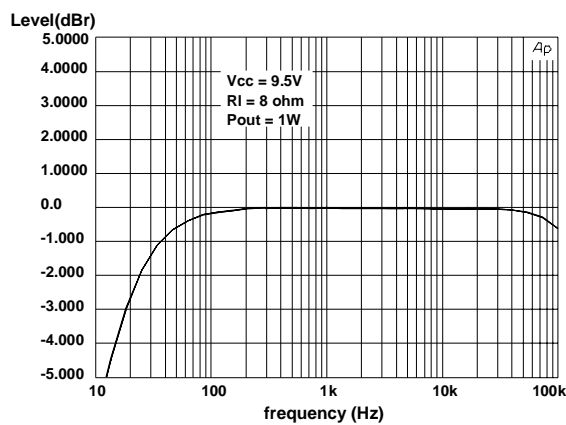

Figure 10. Quiescent Current vs Supply Voltage

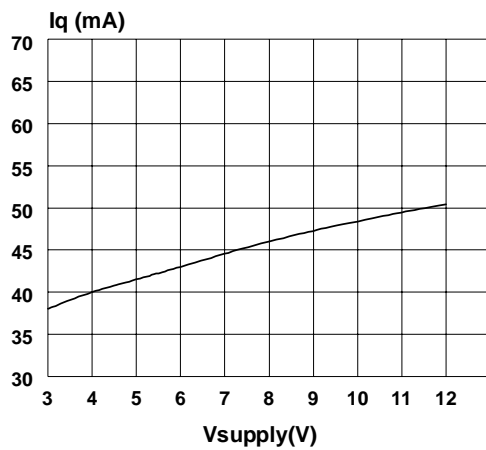

Figure 8. Mute Attenuation vs Vpin.8

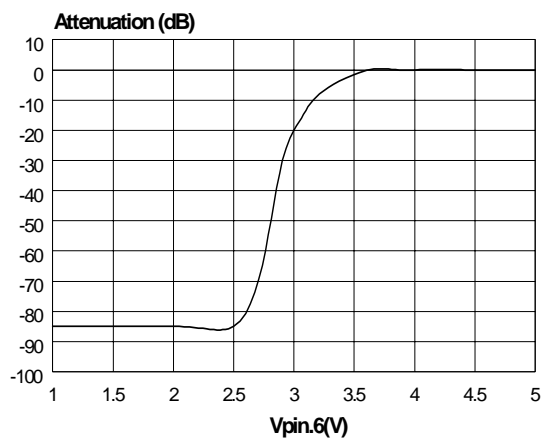

Figure 11. Total Power Dissipation & Efficiency vs Pout

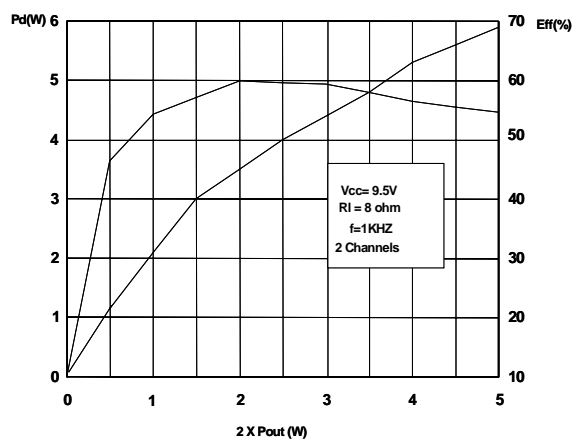

Figure 12. THD+N vs Output Power

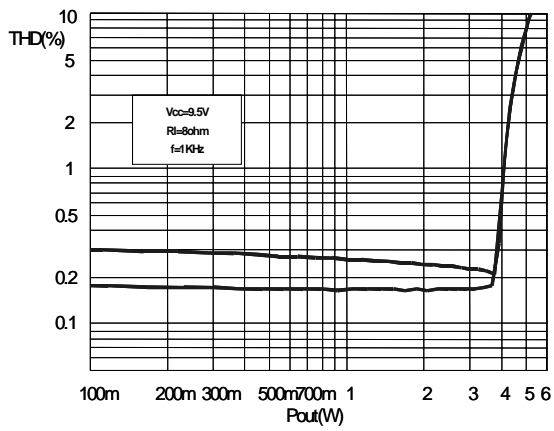

Figure 13. THD+N vs Output Power

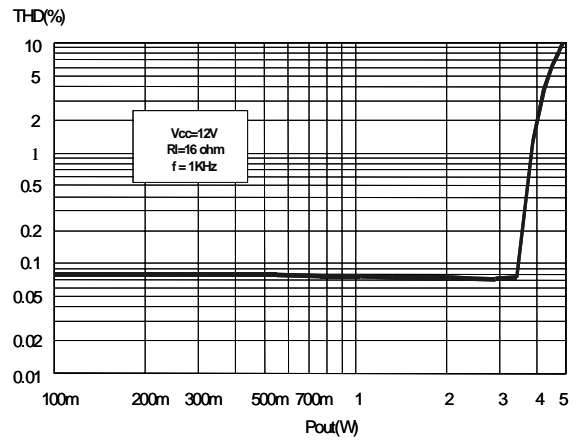

Figure 14. PC Board Component Layout

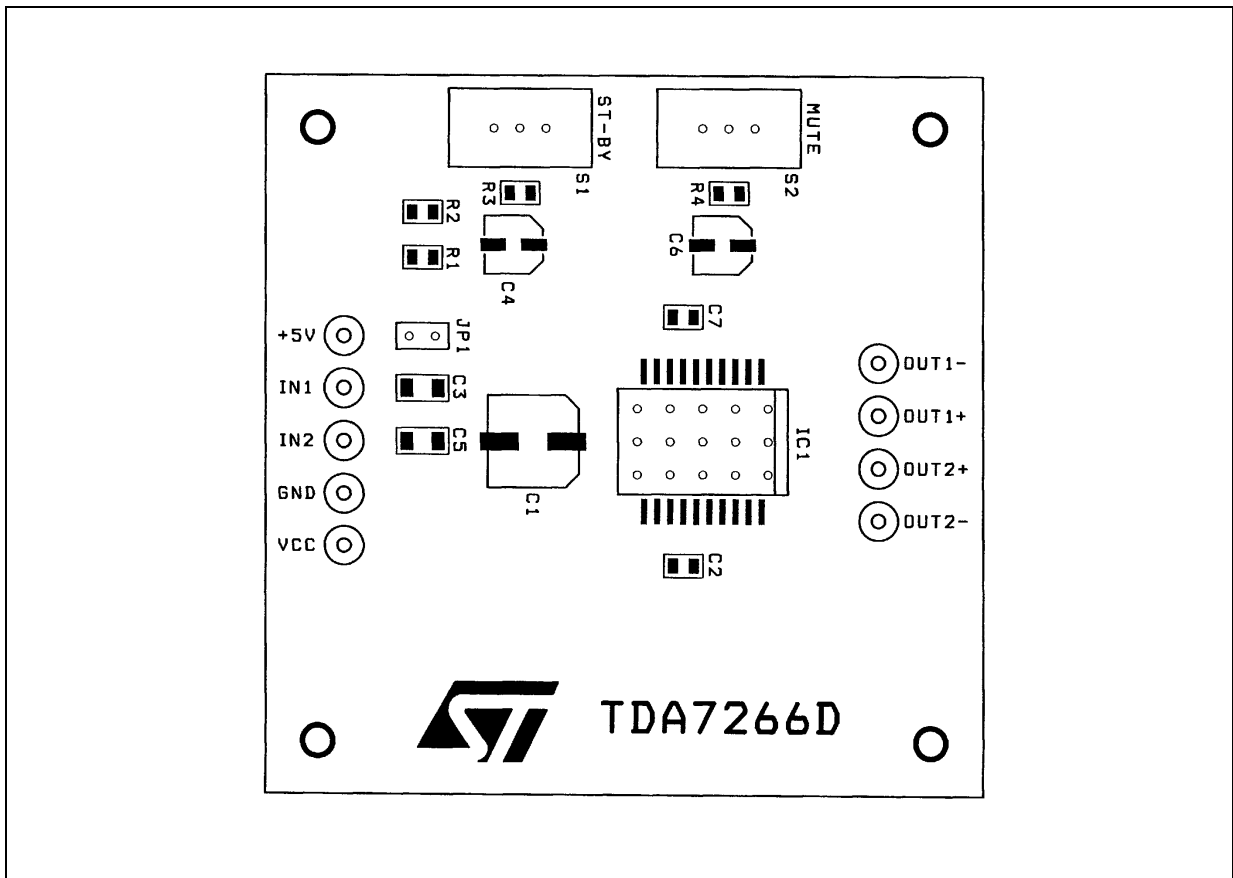

Figure 15. Evaluation Board Top Layer Layout

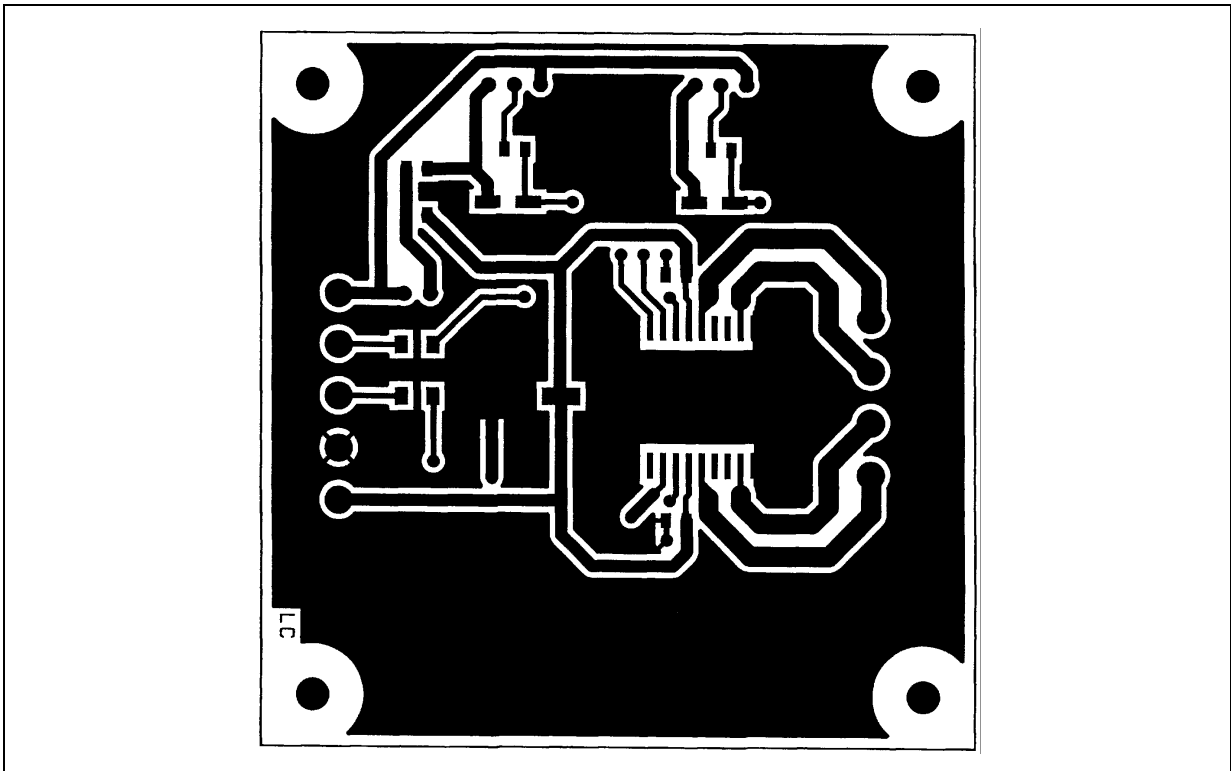
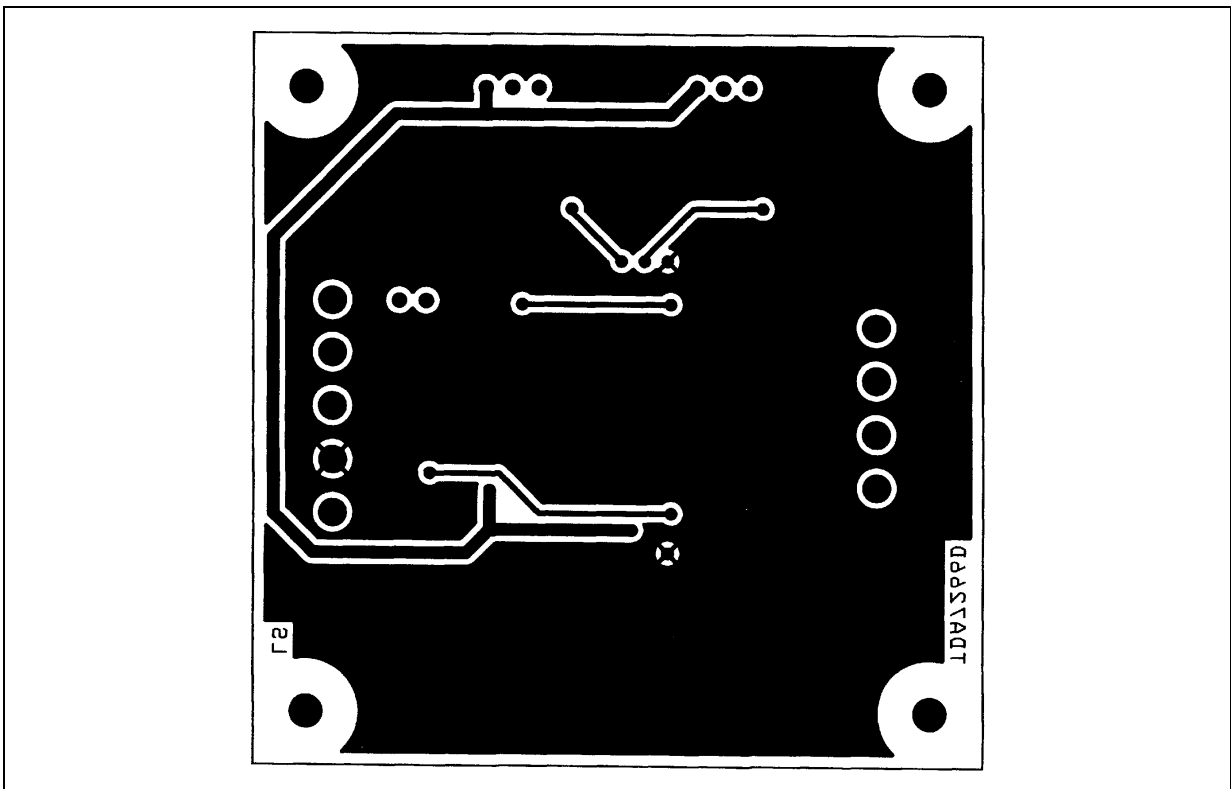

Figure 16. Evaluation Board Bottom Layer Layout



DIM.	mm			inch		
	MIN.	TYP.	MAX.	MIN.	TYP.	MAX.
A			3.6			0.142
a1	0.1		0.3	0.004		0.012
a2			3.3			0.130
a3	0		0.1	0.000		0.004
b	0.4		0.53	0.016		0.021
c	0.23		0.32	0.009		0.013
D (1)	15.8		16	0.622		0.630
D1	9.4		9.8	0.370		0.386
E	13.9		14.5	0.547		0.570
e		1.27			0.050	
e3		11.43			0.450	
E1 (1)	10.9		11.1	0.429		0.437
E2			2.9			0.114
E3	5.8		6.2	0.228		0.244
G	0		0.1	0.000		0.004
H	15.5		15.9	0.610		0.626
h			1.1			0.043
L	0.8		1.1	0.031		0.043
N	8° (typ.)					
S	8° (max.)					
T		10			0.394	

(1) "D and E1" do not include mold flash or protrusions.
 - Mold flash or protrusions shall not exceed 0.15mm (0.006")
 - Critical dimensions: "E", "G" and "a3".

OUTLINE AND MECHANICAL DATA

Weight: 1.9gr

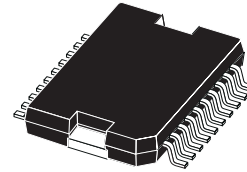

JEDEC MO-166

PowerSO20

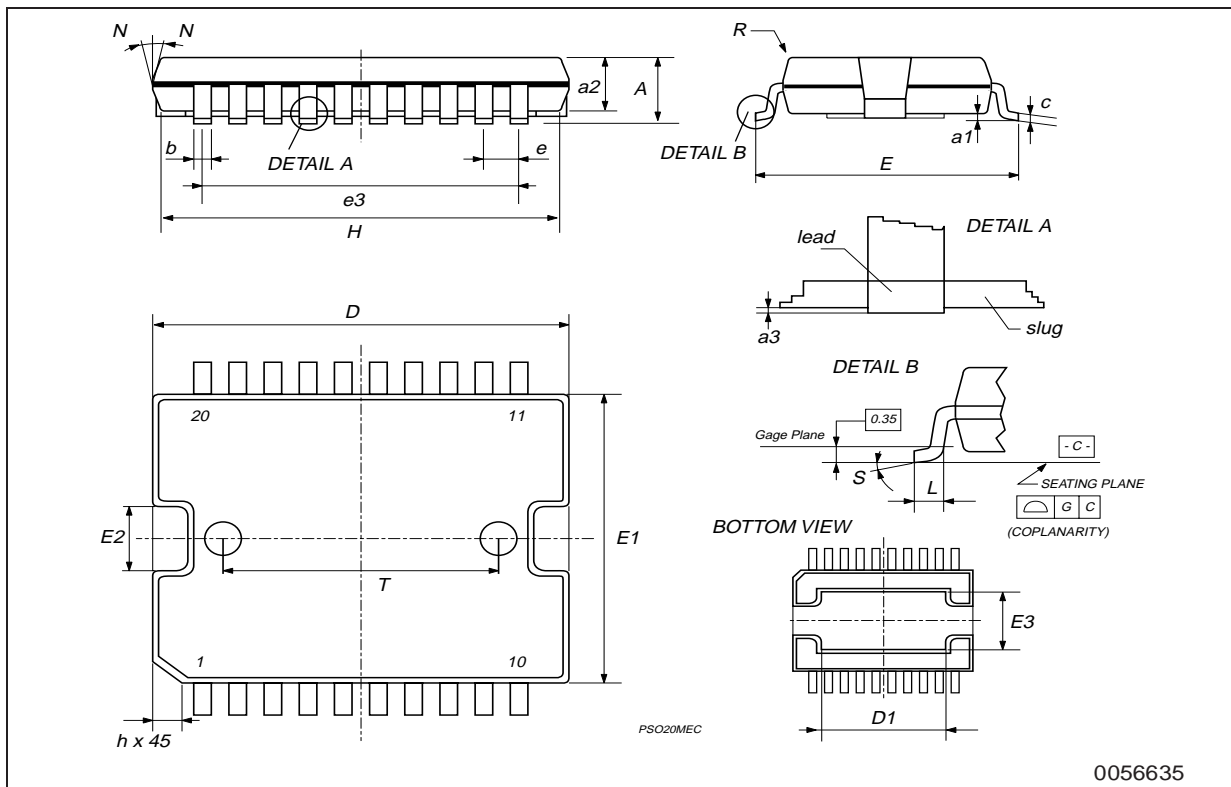

Information furnished is believed to be accurate and reliable. However, STMicroelectronics assumes no responsibility for the consequences of use of such information nor for any infringement of patents or other rights of third parties which may result from its use. No license is granted by implication or otherwise under any patent or patent rights of STMicroelectronics. Specifications mentioned in this publication are subject to change without notice. This publication supersedes and replaces all information previously supplied. STMicroelectronics products are not authorized for use as critical components in life support devices or systems without express written approval of STMicroelectronics.

The ST logo is a registered trademark of STMicroelectronics
© 2003 STMicroelectronics - All Rights Reserved

Australia - Brazil - Canada - China - Finland - France - Germany - Hong Kong - India - Israel - Italy - Japan - Malaysia - Malta - Morocco -
Singapore - Spain - Sweden - Switzerland - United Kingdom - United States.
<http://www.st.com>