

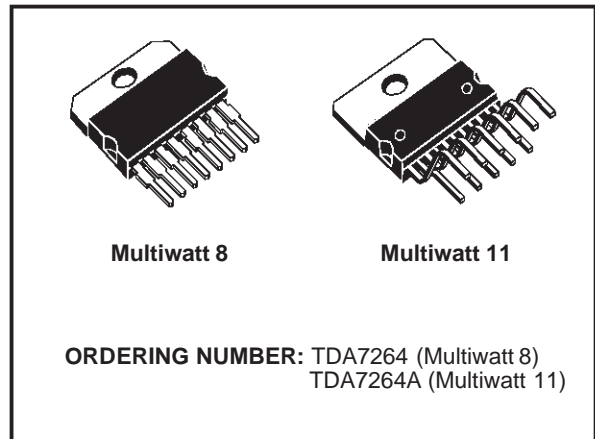

TDA7264 TDA7264A

25 + 25W STEREO AMPLIFIER WITH MUTE/ST-BY

- WIDE SUPPLY VOLTAGE RANGE (UP TO 50V ABS MAX.)
- SPLIT SUPPLY
- HIGH OUTPUT POWER:
25 + 25W @ THD=10%, $R_L = 8\Omega$, $V_S = \pm 20V$
- NO POP AT TURN-ON/OFF
- MUTE (POP FREE)
- STAND-BY FEATURE (LOW I_Q)
- FEW EXTERNAL COMPONENTS
- SHORT CIRCUIT PROTECTION
- THERMAL OVERLOAD PROTECTION



DESCRIPTION

The TDA7264/TDA7264A is class AB dual Audio power amplifier assembled in the Multiwatt package, specially designed for high quality sound ap-

plication as Hi-Fi music centers and stereo TV sets.

Figure 1: Typical Application Circuit for TDA7264

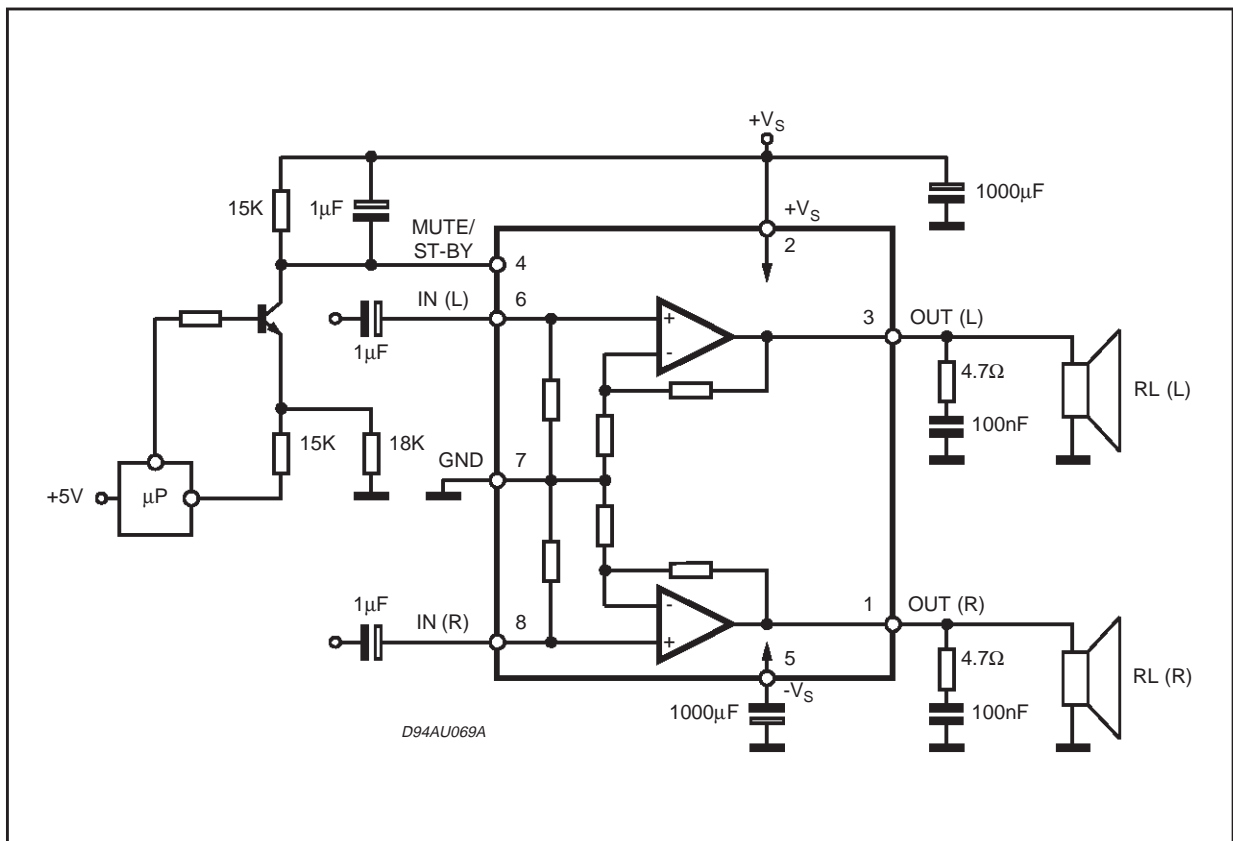

TDA7264 - TDA7264A

Figure 2: Typical Application Circuit for TDA7264A

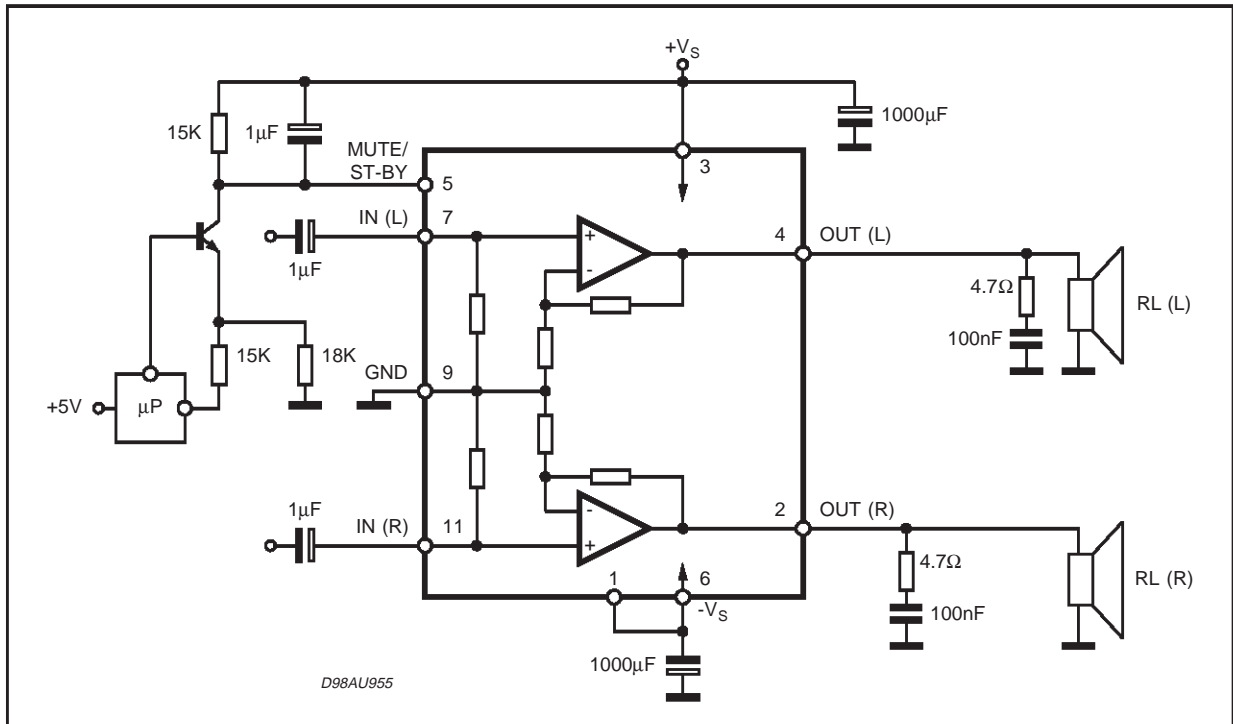

ABSOLUTE MAXIMUM RATINGS

Symbol	Parameter	Value	Unit
V_S	DC Supply Voltage	50	V
I_O	Output Peak Current (internally limited)	4.5	A
P_{tot}	Power Dissipation $T_{case} = 70^\circ\text{C}$	30	W
T_{stg}, T_j	Storage and Junction Temperature	-40 to +150	$^\circ\text{C}$

PIN CONNECTION (Top view)

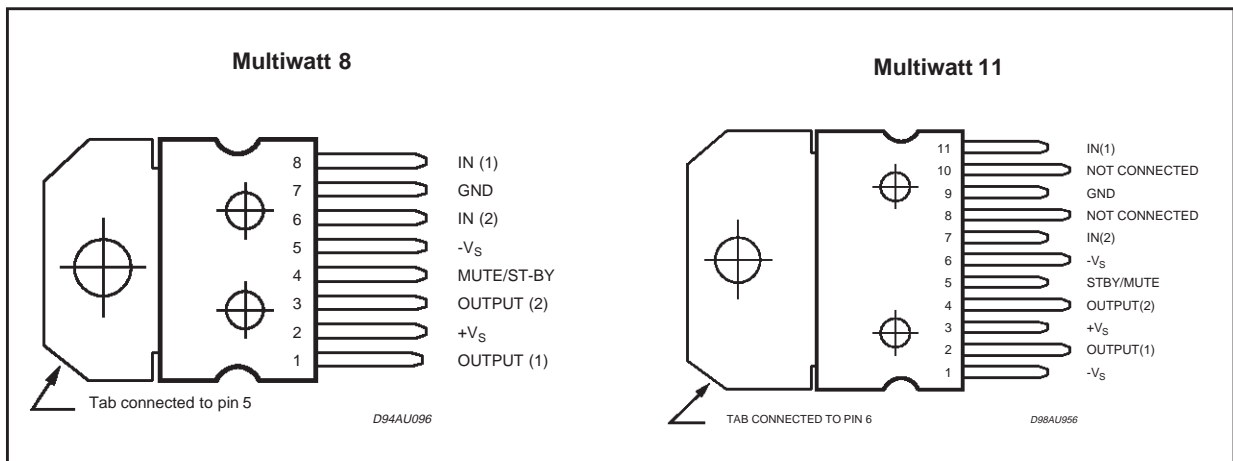

THERMAL DATA

Symbol	Description	Value	Unit
$R_{th\ j-case}$	Thermal Resistance Junction-case	Max 2	$^\circ\text{C}/\text{W}$

ELECTRICAL CHARACTERISTICS (Refer to the test circuit, $V_S \pm 20V$; $R_L = 8\Omega$; $R_s = 50\Omega$; $f = 1KHz$; $T_{amb} = 25^\circ C$, unless otherwise specified.)

Symbol	Parameter	Test Condition	Min.	Typ.	Max.	Unit
V_S	Supply Range		± 5		± 22.5	V
I_q	Total Quiescent Current			80	130	mA
P_O	Music Output Power (*)	THD = 10%; $R_L = 8\Omega$; $V_S \pm 22.5V$		32		W
P_O	Output Power	THD = 10% $R_L = 8\Omega$; $V_S \pm 16V$; $R_L = 4\Omega$	20	25 25		W W
		THD = 1% $R_L = 8\Omega$; $V_S \pm 16V$; $R_L = 4\Omega$		20 20		W W
THD	Total Harmonic Distortion	$R_L = 8\Omega$; $P_O = 1W$; $f = 1KHz$		0.02		%
		$R_L = 8\Omega$; $P_O = 0.1$ to $15W$; $f = 100Hz$ to $15KHz$			0.5	%
		$R_L = 4\Omega$; $P_O = 1W$; $f = 1KHz$		0.03		%
		$R_L = 4\Omega$; $V_S \pm 16V$; $P_O = 0.1$ to $12W$; $f = 100Hz$ to $15KHz$			1	%
C_T	Cross Talk	$f = 1KHz$		70		dB
		$f = 10KHz$		60		dB
SR	Slew Rate			10		V/ μs
G_V	Closed Loop Voltage Gain		29	30	31	dB
ΔG_V	Voltage Gain Matching			0.2		dB
e_N	Total Input Noise	A Curve $f = 20Hz$ to $22KHz$		2.5 3.5	8	μV μV
R_i	Input Resistance		15	20		K Ω
SVR	Supply Voltage Rejection (each channel)	$f_r = 100Hz$; $V_{ripple} = 0.5V_{RMS}$		60		dB
T_j	Thermal Shut-down Junction Temperature			145		$^\circ C$
MUTE FUNCTION [ref: +Vs]						
V_{TMUTE}	Mute / Play Threshold		-7	-6	-5	V
A_M	Mute Attenuation		60	90		dB
STAND-BY FUNCTION [ref: +Vs]						
V_{TST-BY}	Stand-by / Mute Threshold		-3.5	-2.5	-1.5	V
A_{ST-BY}	Stand-by Attenuation			110		dB
I_{qST-BY}	Quiescent Current @ Stand-by			3		mA

Note :

(*) **FULL POWER up to.** $V_S = \pm 22.5V$ with $R_L = 8\Omega$ and $V_S = \pm 16V$ with $R_L = 4\Omega$

MUSIC POWER is the maximal power which the amplifier is capable of producing across the rated load resistance (regardless of non linearity) 1 sec after the application of a sinusoidal input signal of frequency 1KHz.

TDA7264 - TDA7264A

Figure 3: Demo Board Schematic TDA7264

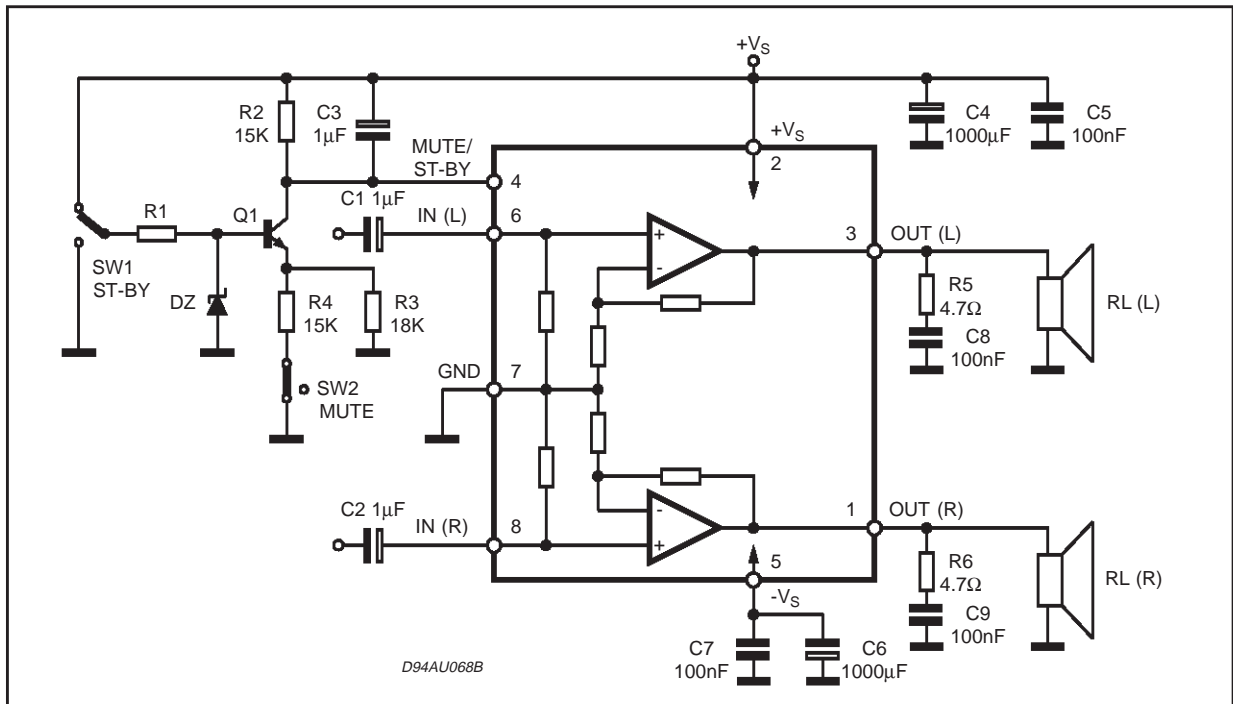

Figure 3a: P.C. Board And Component Layout of the Demo Board Schematic TDA7264 (1:1 Scale)

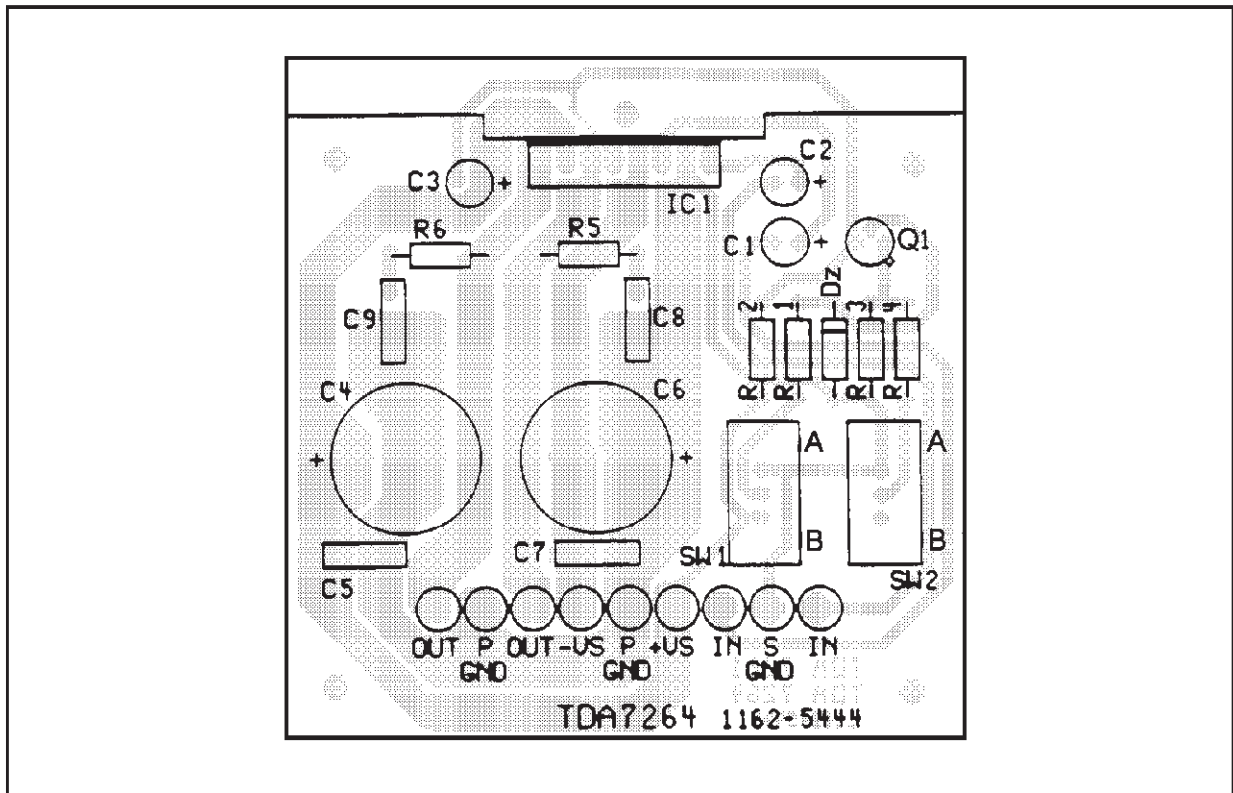

Figure 4: Demo Board Schematic TDA7264A

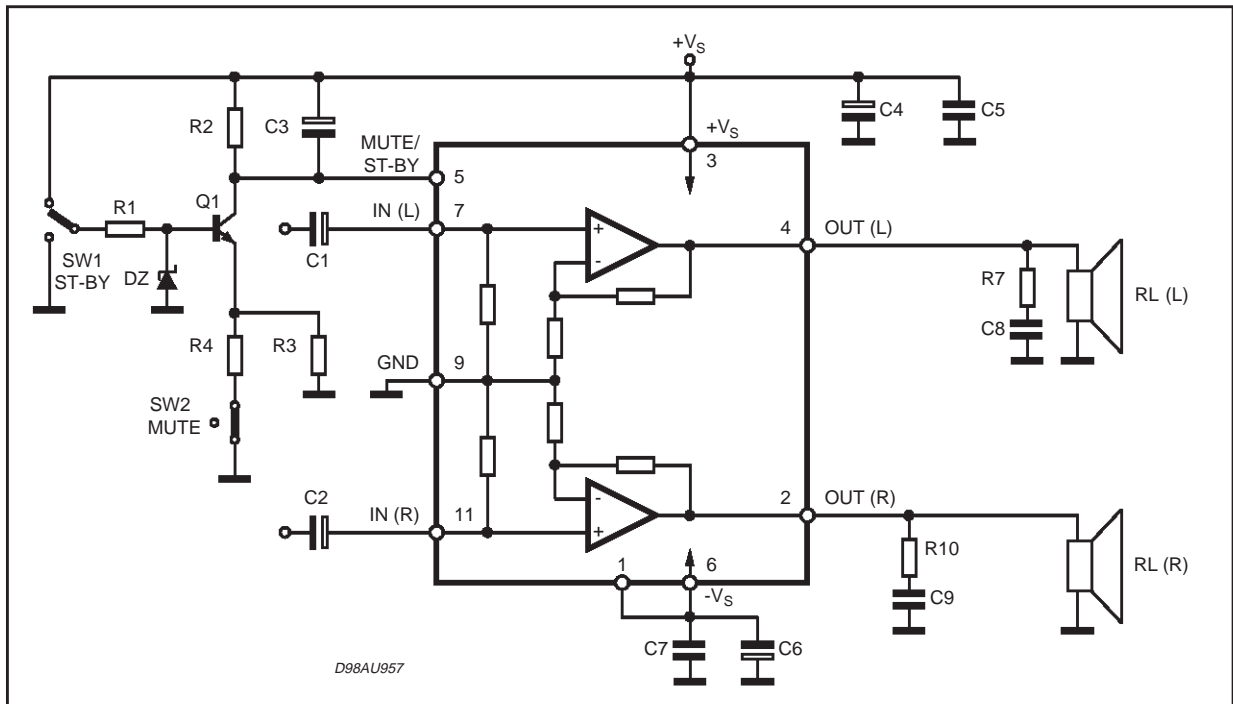
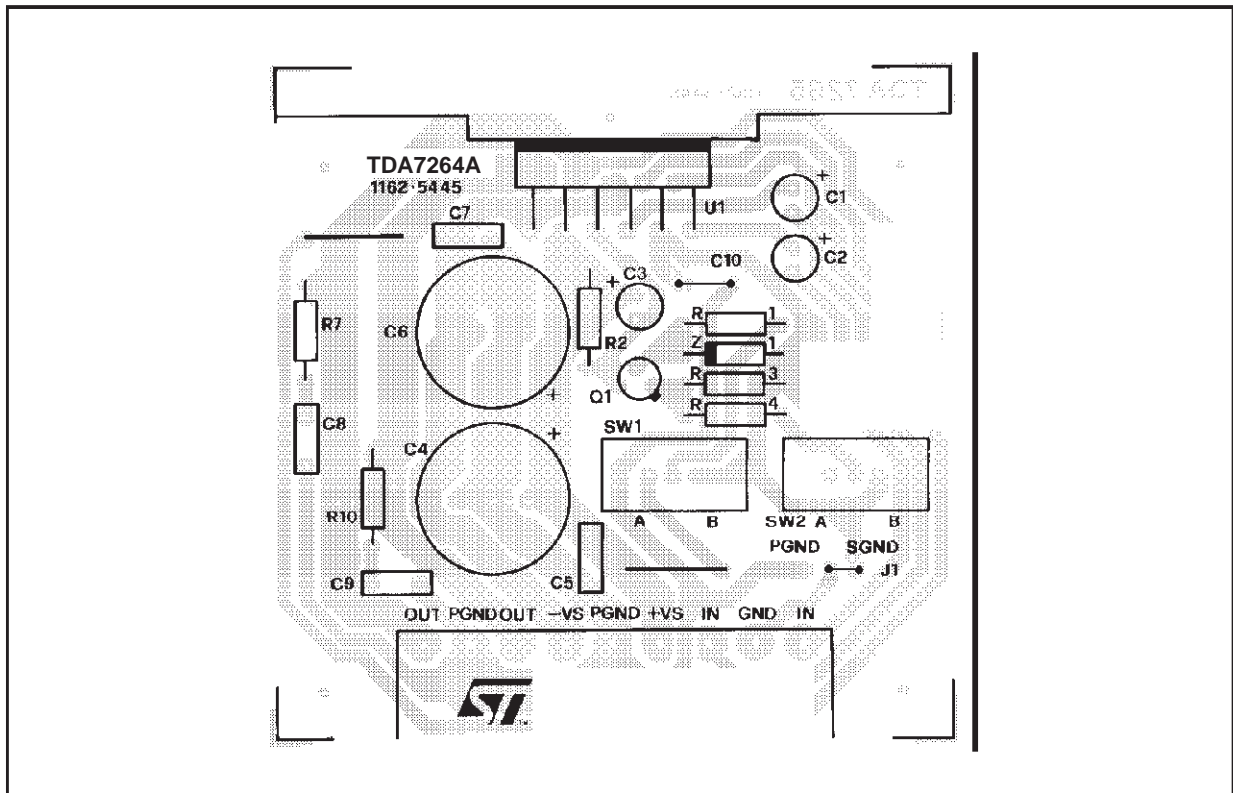

Figure 4a: P.C. Board And Component Layout of the Demo Board Schematic TDA7264A (1:1 Scale)



TDA7264 - TDA7264A

APPLICATIONS SUGGESTION for TDA7264 (Demo Board Schematic)

The recommended values of the external compo-

nents are those shown on the demo board schematic. Different values can be used: the following table can help the designer.

COMPONENTS	RECOMMENDED VALUE	PURPOSE	LARGER THAN RECOMMENDED VALUE	SMALLER THAN RECOMMENDED VALUE
R1	10K Ω	Mute Circuit	Increase of Dz Biasing Current	
R2	15K Ω	Mute Circuit	V _{pin # 4} Shifted Downward	V _{pin # 4} Shifted Upward
R3	18K Ω	Mute Circuit	V _{pin # 4} Shifted Upward	V _{pin # 4} Shifted Downward
R4	15K Ω	Mute Circuit	V _{pin # 4} Shifted Upward	V _{pin # 4} Shifted Downward
R5, R6	4.7 Ω	Frequency Stability	Danger of Oscillations	Danger of Oscillations
C1, C2	1 μ F	Input DC Decoupling		Higher Low Frequency Cutoff
C3	1 μ F	St-By/Mute Time Constant	Larger On/Off Time	Smaller On/Off Time
C4, C6	1000 μ F	Supply Voltage Bypass		Danger of Oscillations
C5, C7	0.1 μ F	Supply Voltage Bypass		Danger of Oscillations
C8, C9	0.1 μ F	Frequency Stability		
Dz	5.1V	Mute Circuit		
Q1	BC107	Mute Circuit		

APPLICATIONS SUGGESTION for TDA7264A (Demo Board Schematic)

The recommended values of the external compo-

nents are those shown are the demo board schematic different values can be used: the following table can help the designer.

COMPONENTS	RECOMMENDED VALUE	PURPOSE	LARGER THAN RECOMMENDED VALUE	SMALLER THAN RECOMMENDED VALUE
R1	10K Ω	Mute Circuit	Increase of Dz Biasing Current	
R2	15K Ω	Mute Circuit	V _{pin # 5} Shifted Downward	V _{pin # 5} Shifted Upward
R3	18K Ω	Mute Circuit	V _{pin # 5} Shifted Upward	V _{pin # 5} Shifted Downward
R4	15K Ω	Mute Circuit	V _{pin # 5} Shifted Upward	V _{pin # 5} Shifted Downward
R7, R10	4.7 Ω	Frequency Stability	Danger of Oscillations	Danger of Oscillations
C1, C2	1 μ F	Input DC Decoupling		Higher Low Frequency Cutoff
C3	1 μ F	St-By/Mute Time Constant	Larger On/Off Time	Smaller On/Off Time
C4, C6	1000 μ F	Supply Voltage Bypass		Danger of Oscillations
C5, C7	0.1 μ F	Supply Voltage Bypass		Danger of Oscillations
C8, C9	0.1 μ F	Frequency Stability		
Dz	5.1V	Mute Circuit		
Q1	BC107	Mute Circuit		

MUTE, STAND-BY TRUTH TABLE

SW1	SW2	
A	A	STAND-BY
A	B	STAND-BY
B	B	MUTE
B	A	PLAY

Figure 5: Quiescent Current vs. Supply Voltage

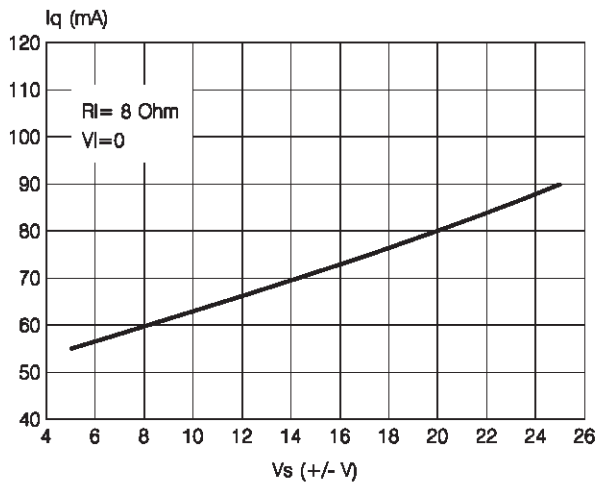

Figure 6: Frequency Response

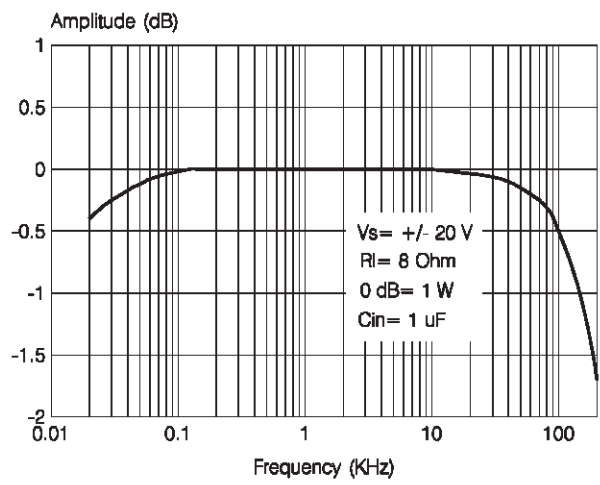

Figure 7: Output Power vs Supply Voltage

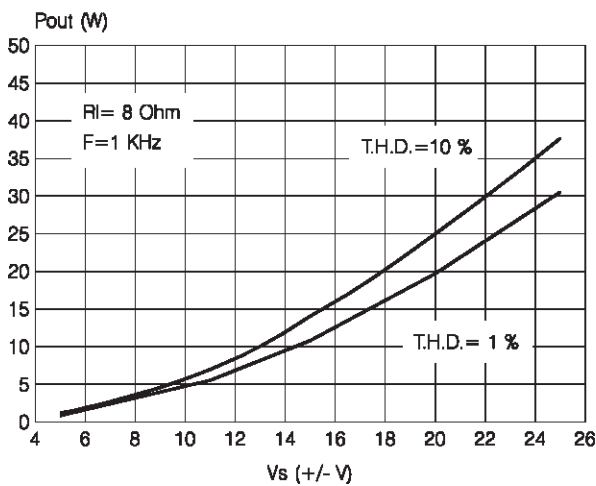

Figure 8: Distortion vs. Output Power

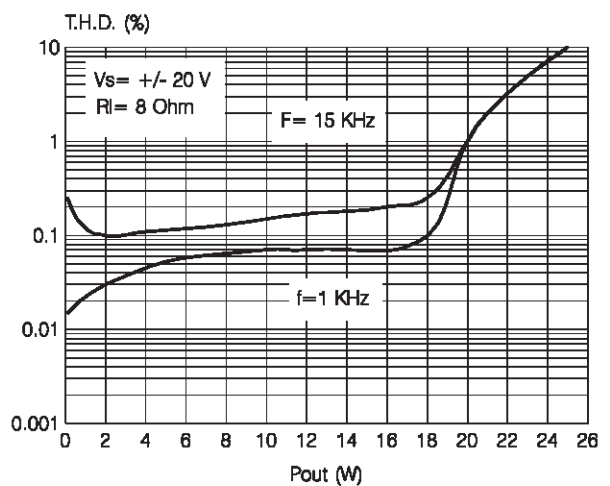

Figure 9: Crosstalk vs. Frequency

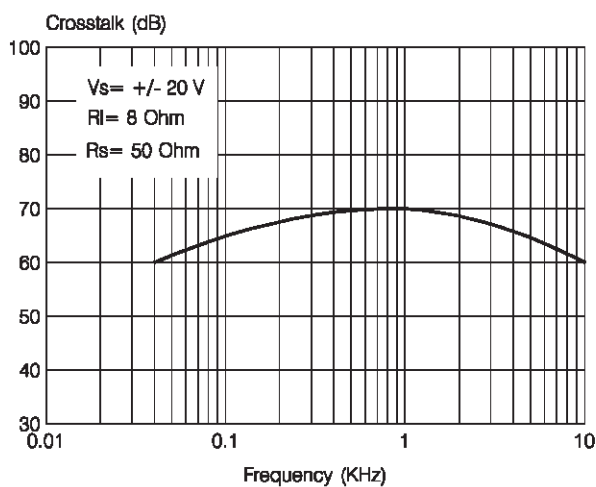

Figure 10: Supply Voltage Rejection vs. Frequency

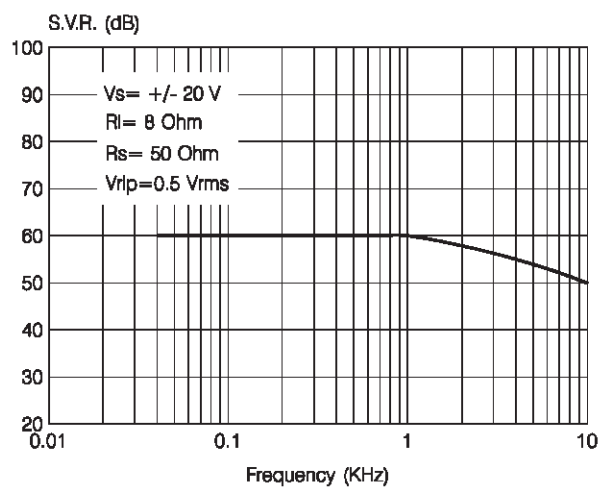

Figure 11: Attenuation & Total Quiescent Current vs. V_{pin4} Voltage

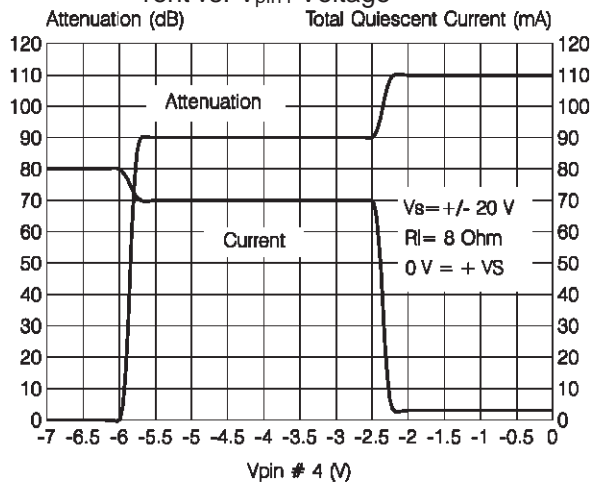
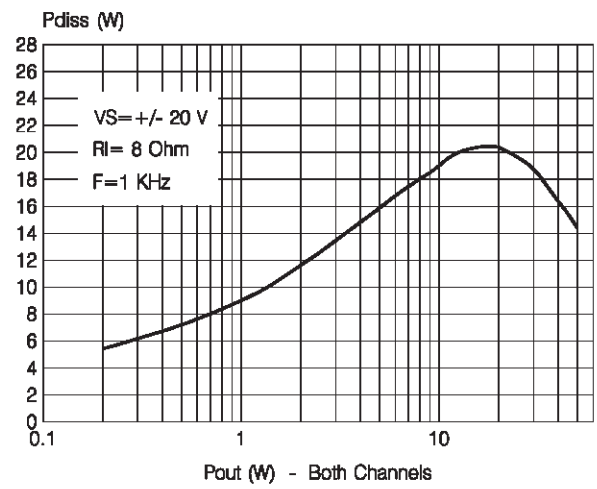

Figure 12: Power Dissipation vs. Output Power



MUTE STAND-BY FUNCTION

The pin 4 (MUTE/STAND-BY) controls the amplifier status by two different thresholds, referred to +Vs.

- When V_{pin4} higher than $+Vs - 2.5V$ the amplifier is in Stand-by mode and the final stage generators are off

- when V_{pin4} is between $+Vs - 2.5V$ and $+Vs - 6V$ the final stage current generators are switched on and the amplifier is in mute mode
- when V_{pin4} is lower than $+Vs - 6V$ the amplifier is play mode.

Figure 13

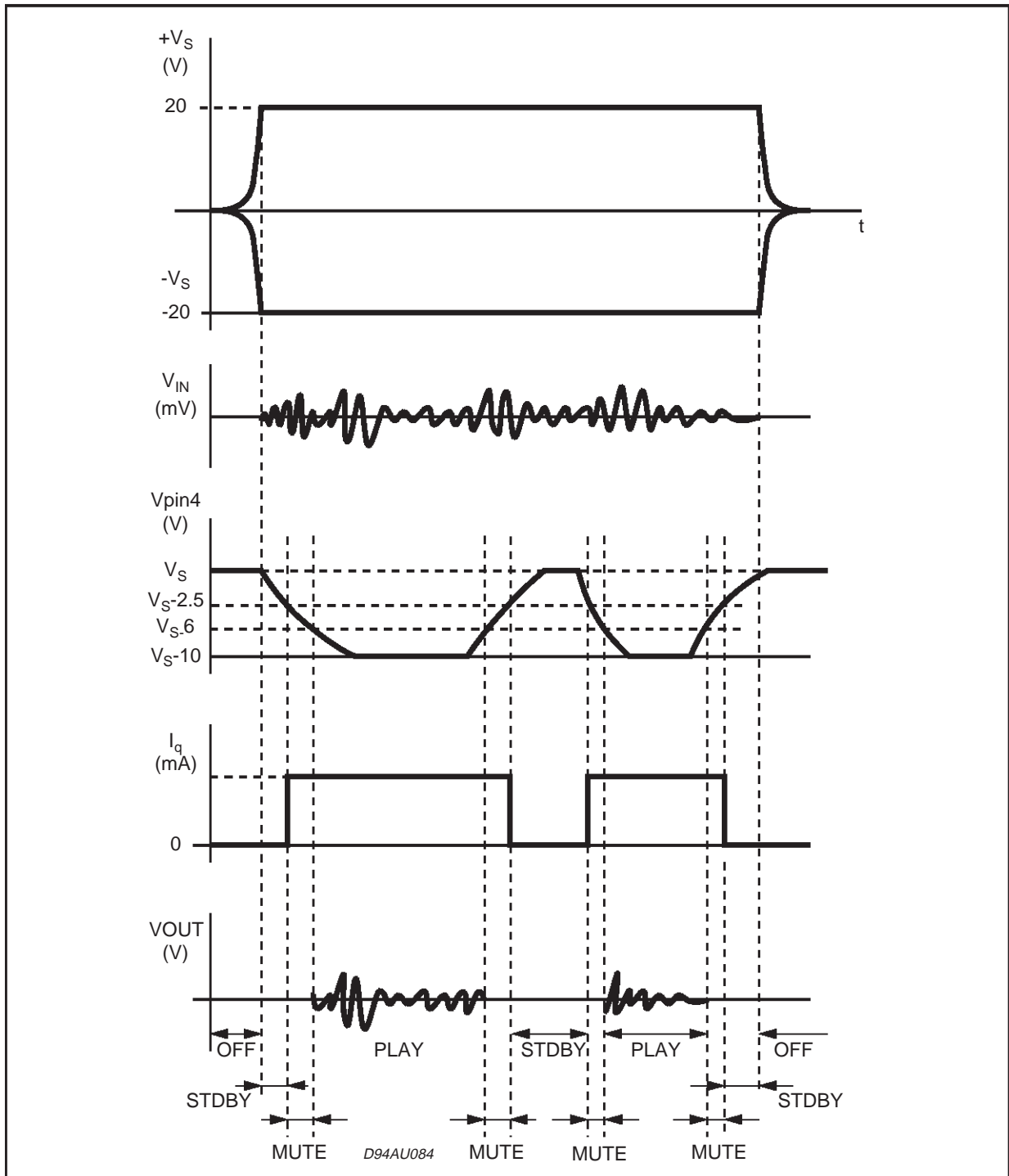

DIM.	mm			inch		
	MIN.	TYP.	MAX.	MIN.	TYP.	MAX.
A			5			0.197
B			2.65			0.104
C			1.6			0.063
E	0.49		0.55	0.019		0.022
F	0.78		0.85	0.030		0.033
G	2.40	2.54	2.68	0.094	0.10	0.105
G1	17.64	17.78	17.92	0.69	0.70	0.71
H1	19.6			0.772		
H2			20.2			0.795
L	20.35		20.65	0.80		0.81
L2	17.05	17.20	17.35	0.67	0.68	0.68
L3	17.25	17.5	17.75	0.679	0.689	0.699
L4	10.3	10.7	10.9	0.406	0.421	0.429
L7	2.65		2.9	0.104		0.114
S	1.9		2.6	0.075		0.102
S1	1.9		2.6	0.075		0.102
U	0.40		0.55	0.015		0.022
Z	0.70		0.85	0.028		0.034
Dia1	3.65		3.85	0.144		0.152

OUTLINE AND MECHANICAL DATA

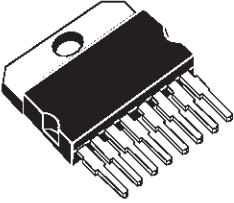

Multiwatt8 (Pin. 5 Gnd)

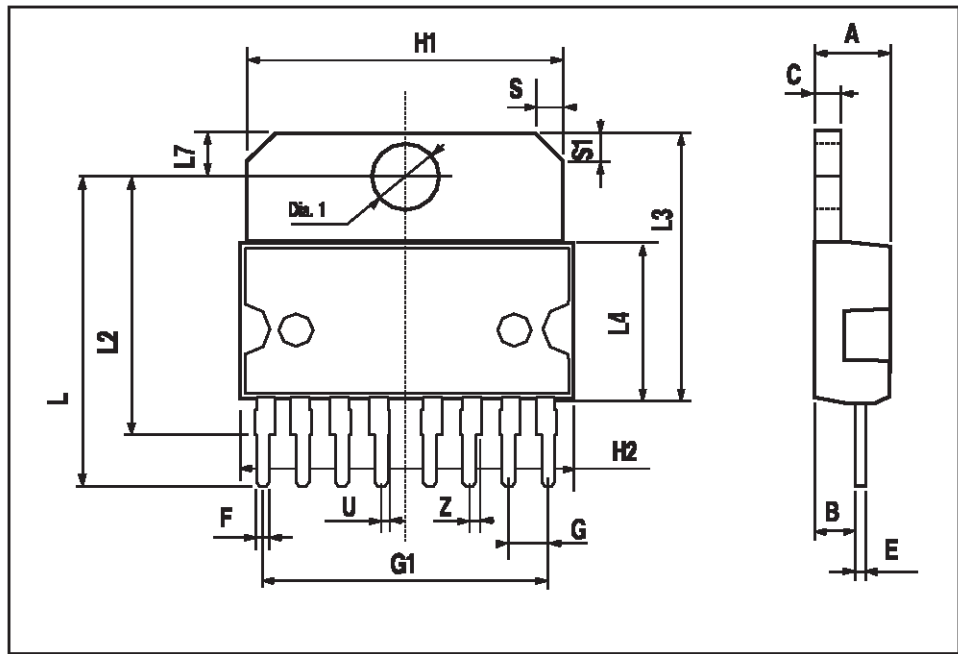

DIM.	mm			inch		
	MIN.	TYP.	MAX.	MIN.	TYP.	MAX.
A			5			0.197
B			2.65			0.104
C			1.6			0.063
D		1			0.039	
E	0.49		0.55	0.019		0.022
F	0.88		0.95	0.035		0.037
G	1.45	1.7	1.95	0.057	0.067	0.077
G1	16.75	17	17.25	0.659	0.669	0.679
H1	19.6			0.772		
H2			20.2			0.795
L	21.9	22.2	22.5	0.862	0.874	0.886
L1	21.7	22.1	22.5	0.854	0.87	0.886
L2	17.4		18.1	0.685		0.713
L3	17.25	17.5	17.75	0.679	0.689	0.699
L4	10.3	10.7	10.9	0.406	0.421	0.429
L7	2.65		2.9	0.104		0.114
M	4.25	4.55	4.85	0.167	0.179	0.191
M1	4.73	5.08	5.43	0.186	0.200	0.214
S	1.9		2.6	0.075		0.102
S1	1.9		2.6	0.075		0.102
Dia1	3.65		3.85	0.144		0.152

OUTLINE AND MECHANICAL DATA

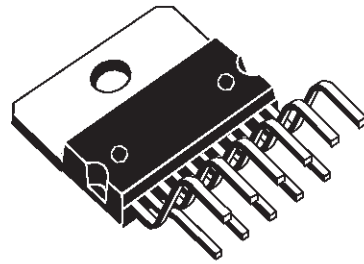

Multiwatt11 V

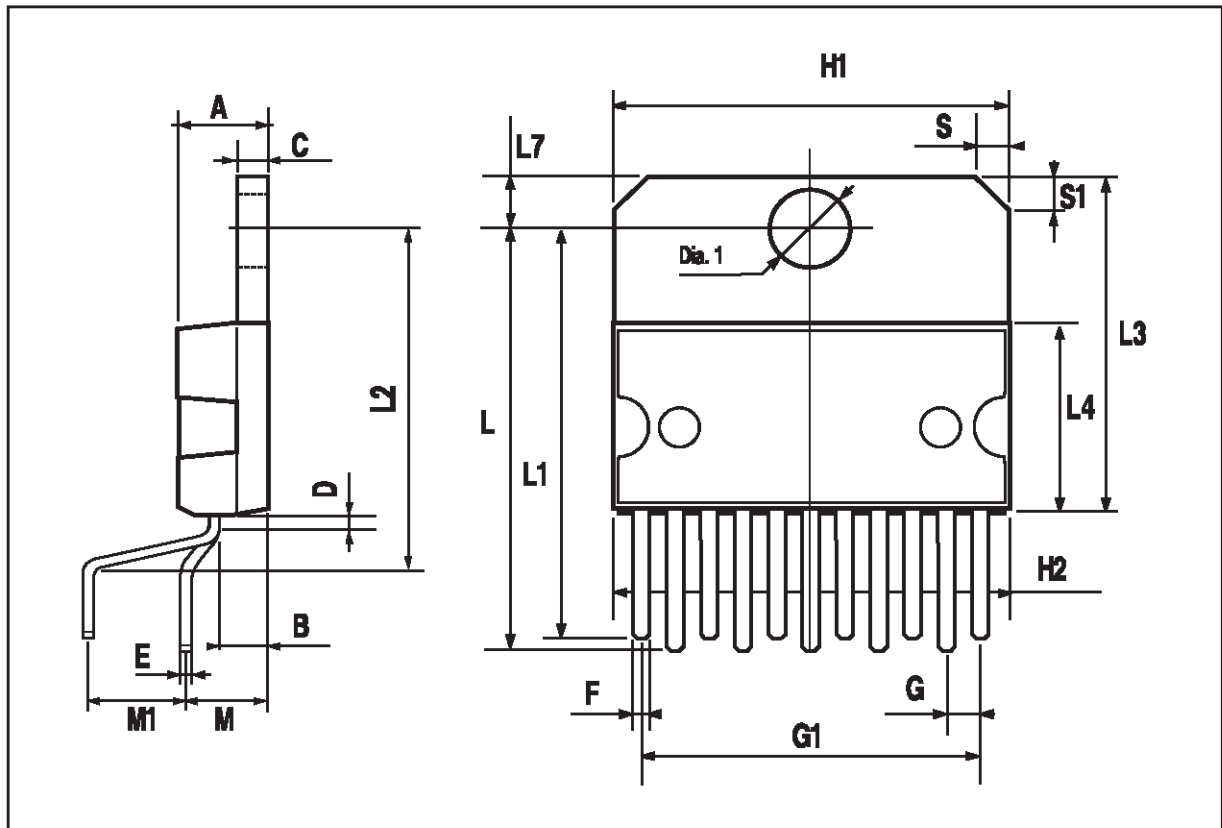

Information furnished is believed to be accurate and reliable. However, STMicroelectronics assumes no responsibility for the consequences of use of such information nor for any infringement of patents or other rights of third parties which may result from its use. No license is granted by implication or otherwise under any patent or patent rights of STMicroelectronics. Specification mentioned in this publication are subject to change without notice. This publication supersedes and replaces all information previously supplied. STMicroelectronics products are not authorized for use as critical components in life support devices or systems without express written approval of STMicroelectronics.

The ST logo is a registered trademark of STMicroelectronics

© 1999 STMicroelectronics – Printed in Italy – All Rights Reserved
STMicroelectronics GROUP OF COMPANIES

Australia - Brazil - Canada - China - France - Germany - Italy - Japan - Korea - Malaysia - Malta - Mexico - Morocco - The Netherlands - Singapore - Spain - Sweden - Switzerland - Taiwan - Thailand - United Kingdom - U.S.A.

<http://www.st.com>