

DUAL POWER AMPLIFIER TDA2822

GENERAL DESCRIPTION

The TDA2822 is a monolithic integrated circuit in an 8 lead Minidip package. It is intended for use as dual audio power amplifier in portable cassette tape players and radios.

Outline Drawing

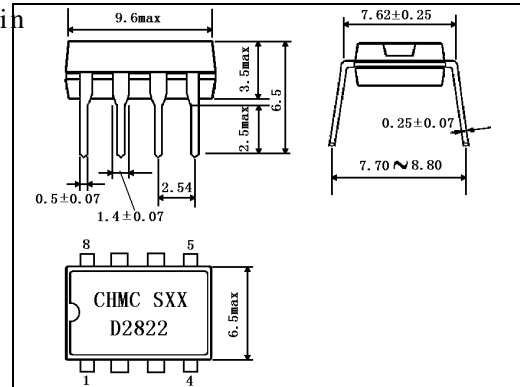

DIP8

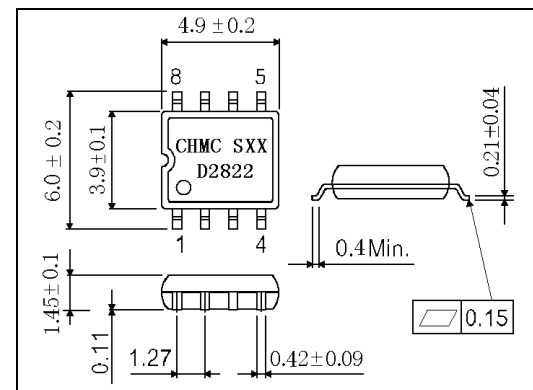

SOP8

FEATURES

- Dual Low-voltage power amplifier
- Supply voltage down to 1.8V
- Low crossover distortion
- Low quiescent current
- Bridge or stereo configuration

BLOCK DIAGRAM

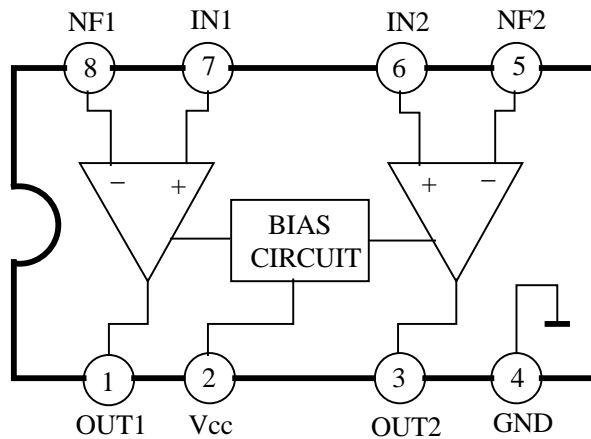

PINNING

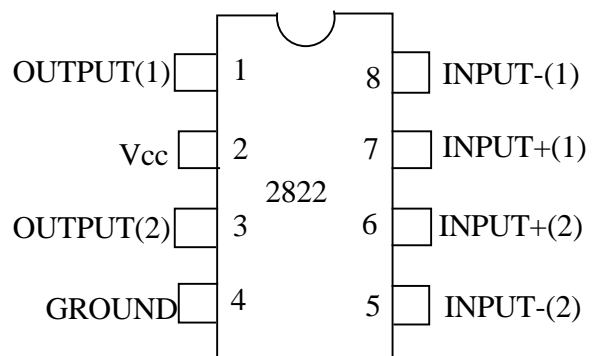

MAXIMUM RATINGS

Characteristics	Symbol	Value	Unit
Supply Voltage	V _{CC}	15	V
Output Peak Current	I _{pk}	1	A
Total Power Dissipation(at T _{amb} =50°C)	P _D	1	W
Total Power Dissipation(at T _{case} =50°C)	P _D	1.4	W
Operating Ambient Temperature Range	T _a	-20~70	°C
Storage Temperature Range	T _{stg}	-40~150	°C

ELECTRICAL CHARACTERISTICS

1. Stereo Test Circuit(Unless otherwise specified V_{CC}=6V,T_{amb}=25°C)

Characteristic	Symbol	Test Condition	Min.	Typ.	Max.	Unit
Supply Voltage	V _{CC}		1.8		15	V
Quiescent Output Voltage	V _o			2.7		V
		V _{CC} =3V		1.2		V
Quiescent Drain Current	I _d			6	9	mA
Input Bias Current	I _{BA}			100		nA
Output Power (Each Channel)	P _o	d=10% f=1kHz V _{CC} =3V R _L =4		110		mW
		V _{CC} =3V R _L =32		20		
		d=10% f=1kHz V _{CC} =9V R _L =8	0.4	1		W
		V _{CC} =6V R _L =4 V _{CC} =4.5V R _L =4		0.65 0.32		
Distortion	THD	P _o =0.5W R _L =8 f=1kHz V _{CC} =9V		0.3		%
Closed Loop Voltage Gain	A _{vf}	f=1kHz		40		dB
Channel Balance	ΔA _{vf}				± 1	dB
Input Resistance	R _i	f=1kHz	100			k
Total Input Noise	V _{NI}	R _s =10k B=Cure A		2		μV
		R _s =10k B=22Hz to22kHz		3		
Supply Voltage rejection	SVR	f=100Hz C1=C2=100 μF	24	30		dB
Channel Separation	CSR	f=1kHz		50		dB

2. Bridge Test Circuit (Unless otherwise specified $V_{CC}=6V, T_{amb}=25^{\circ}C$)

Characteristic	Sym- bol	Test Condition	Min.	Typ.	Max.	Unit
Supply Voltage	V_{CC}		1.8		15	V
Quiescent Drain Current	I_D	$R_L=\infty$		6	9	mA
Output Offset Voltage (Between the Outputs)	V_{OS}	$R_L=8$			± 50	mV
Input Bias Current	I_B			100		nA
Output Power	P_O	$d=10\%$ $f=1kHz$ $V_{CC}=9V$ $R_L=16$ $V_{CC}=6V$ $R_L=8$ $V_{CC}=4.5V$ $R_L=8$ $V_{CC}=4.5V$ $R_L=4$		2 1.35 0.7 1		W
		$V_{CC}=3V$ $R_L=4$ $V_{CC}=2V$ $R_L=4$	200	350 80		mW
Distortion	THD	$P_O=0.5W$ $R_L=8$ $f=1kHz$		0.2		%
Closed Loop Voltage Gain	A_{vf}	$f=1kHz$		40		dB
Input Resistance	R_i	$f=1kHz$	100			k
Total Input Noise	V_{NI}	$R_s=10k$ Curve A		2.5		μV
		$R_s=10k$ B=22Hz to 22kHz		3		
Supply Voltage Rejection	SVR	$f=100Hz$		40		dB
Power Bandwidth (-3dB)	B	$R_L=8$ $P_O=1W$		120		kHz

TEST CIRCUIT

1. STEREO TEST CIRCUIT

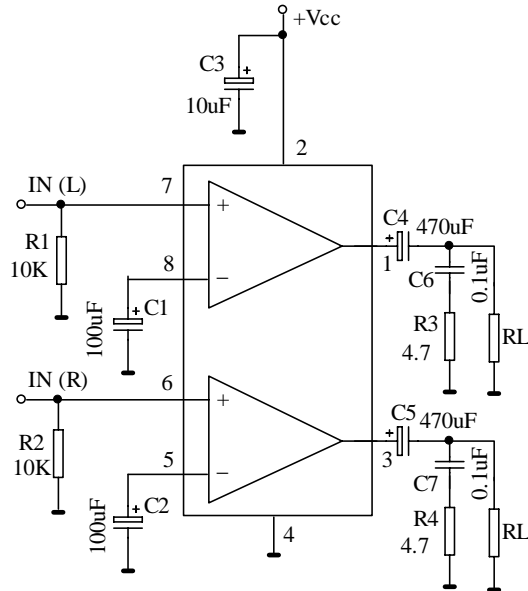

2. BRIDGE TEST CIRCUIT

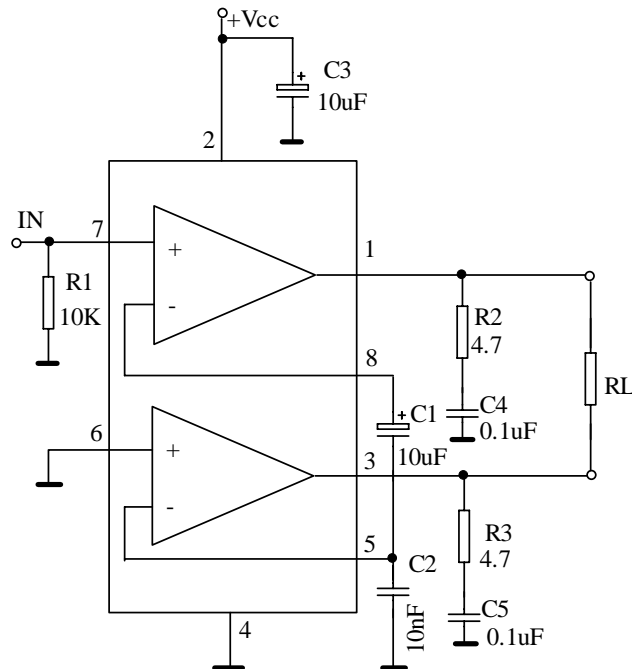

APPLICATION CIRCUIT

1. Typical application in portable players

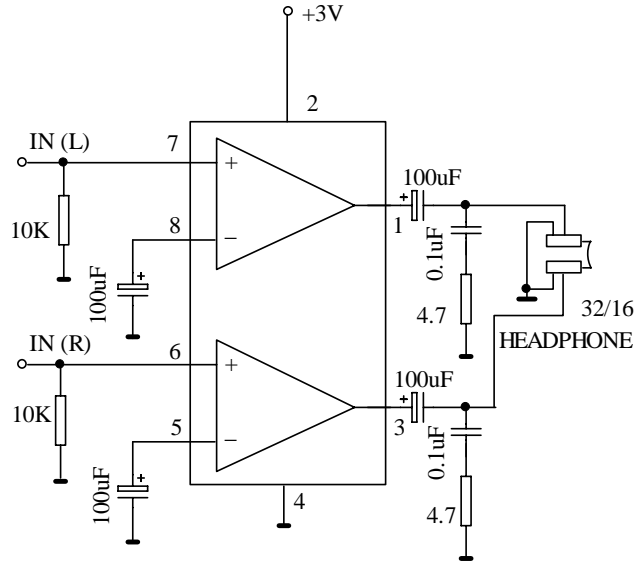

2. Application circuit for portable radio receivers

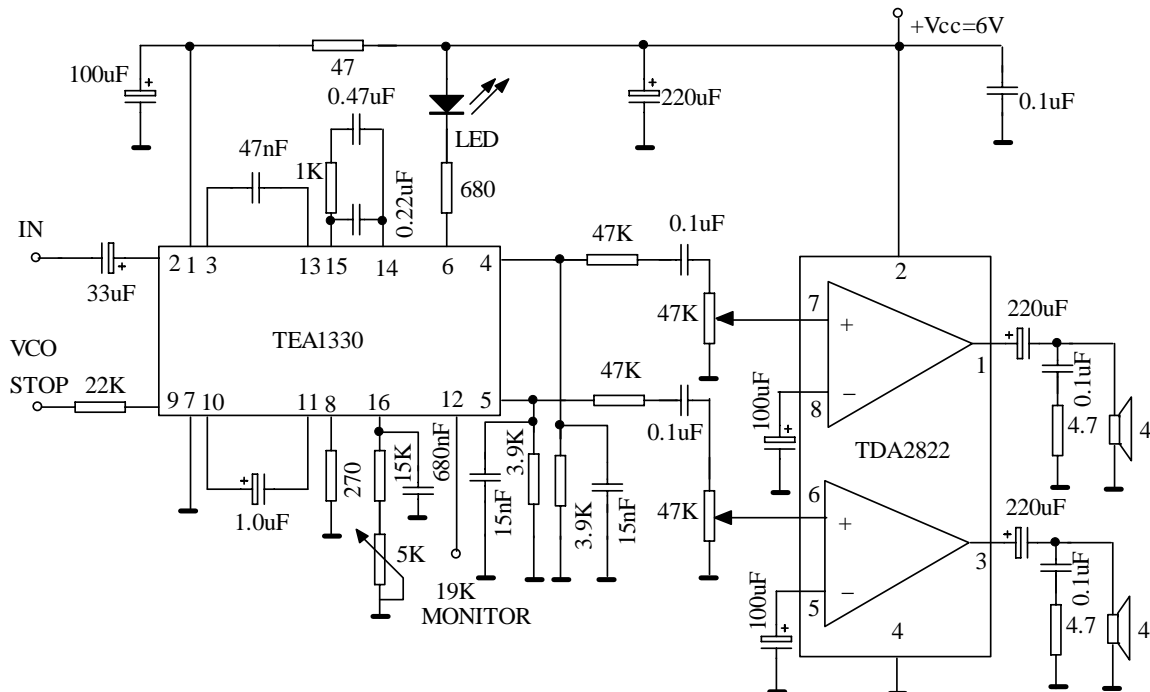

3. Portable radio cassette players

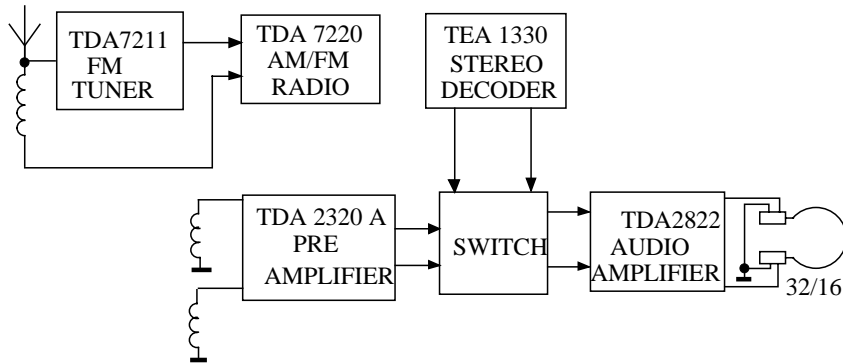

4. Portable stereo radios

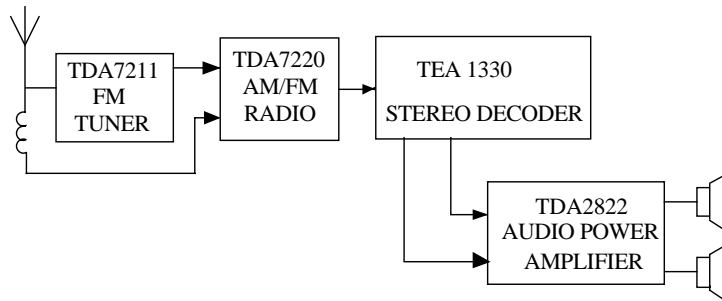

5. Low cost application for portables (using only one 100 μ F output capacitor)

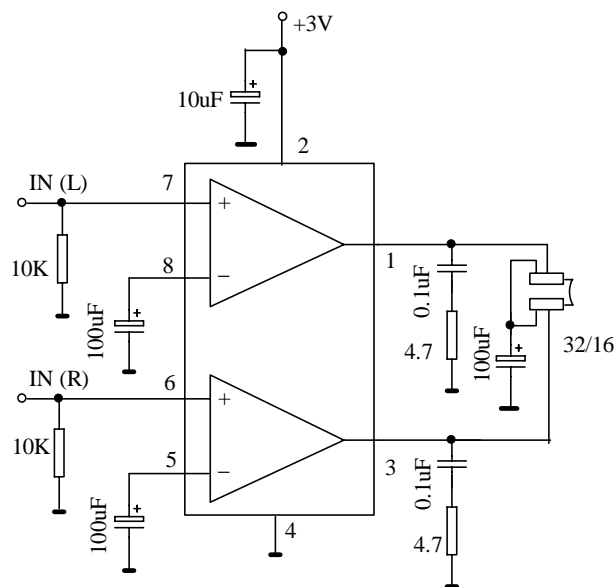

CHARACTERISTICS CURVES

Fig. 4 - Quiescent current vs. supply voltage

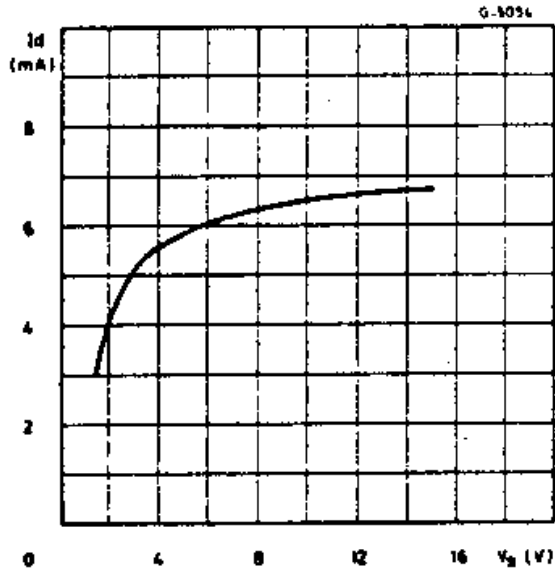

Fig. 5 - Supply voltage rejection vs. frequency (stereo)

