

STEREO AMPLIFIER

- WIDE SUPPLY VOLTAGE RANGE (3 to 36V)
- SINGLE OR SPLIT SUPPLY OPERATION
- VERY LOW CURRENT CONSUMPTION (0.8mA)
- VERY LOW DISTORTION
- NO POP-NOISE

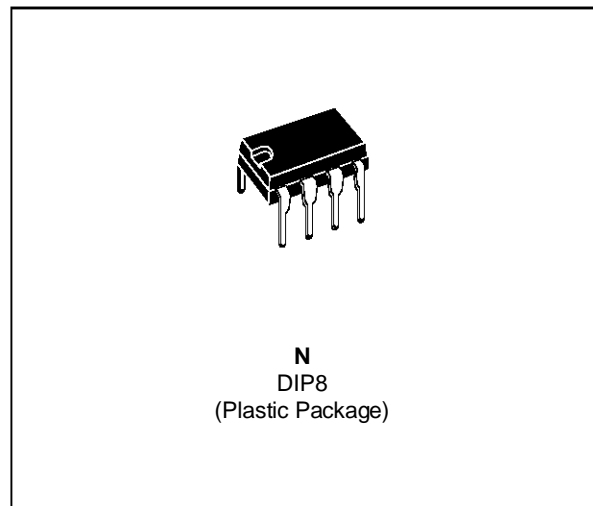

DESCRIPTION

The TDA2320A is a stereo class A preamplifier intended for application in portable cassette players and high quality audio systems.

The TDA2320A is a monolithic integrated circuit in a 8 lead plastic dip.

ORDER CODES

Part Number	Temperature Range	Package
		N
TDA2320A	-40°C, +105°C	•

PIN CONNECTIONS (top view)

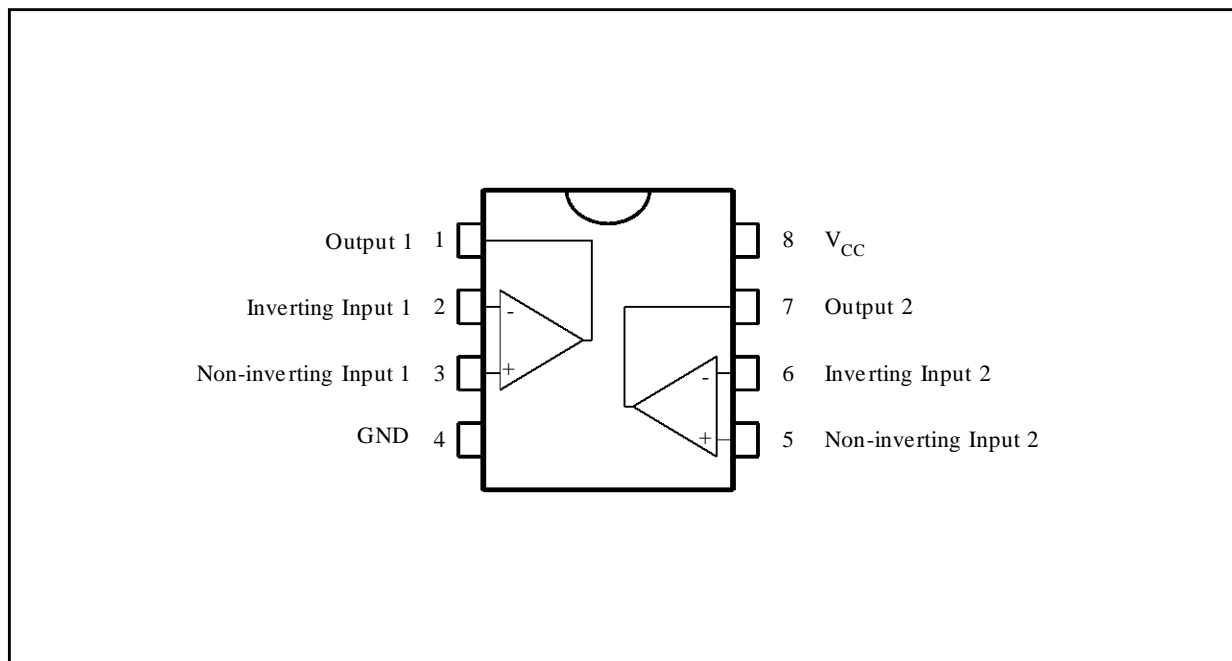

SCHEMATIC DIAGRAM (1/2 TDA2320A)

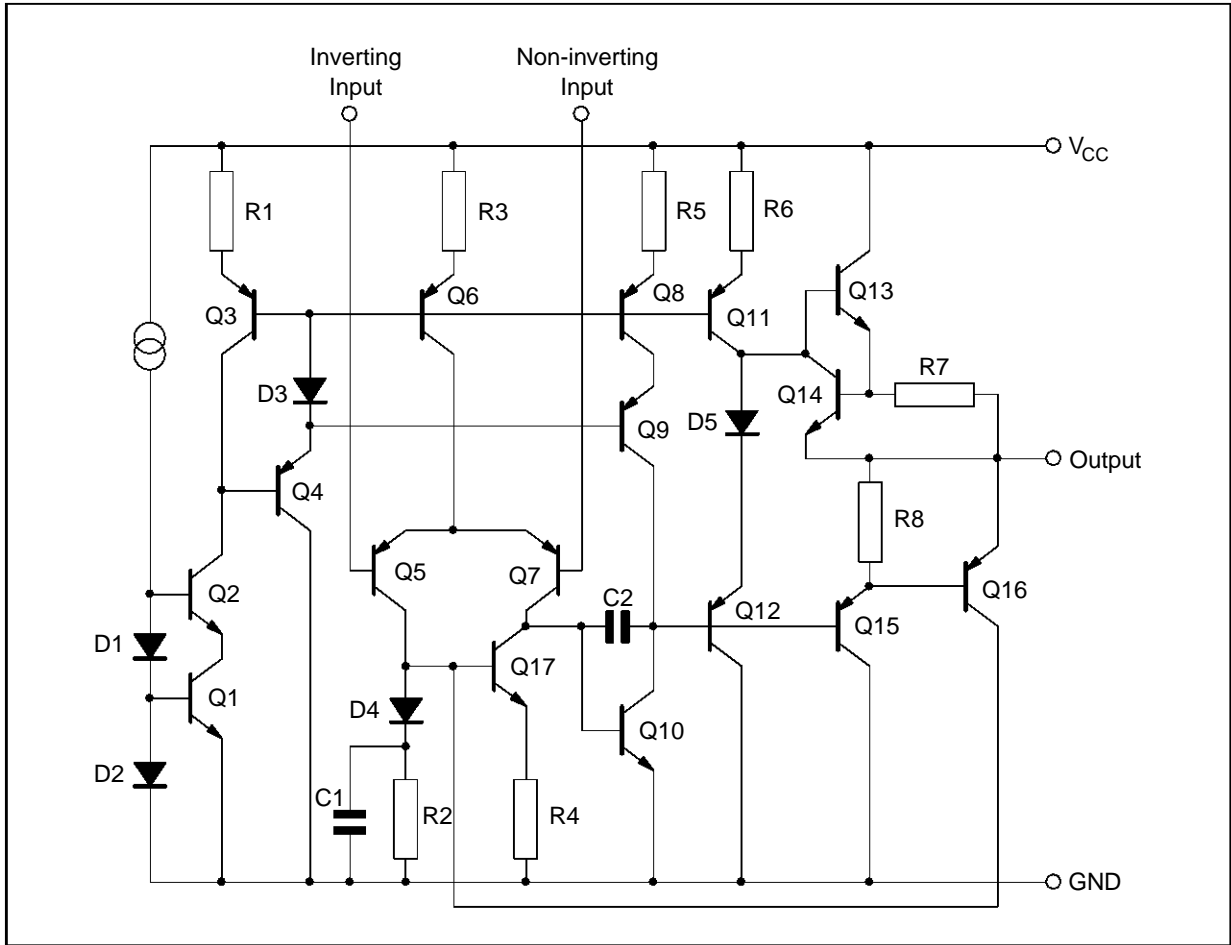

ABSOLUTE MAXIMUM RATINGS

Symbol	Parameter	Value	Unit
V _{CC}	Supply Voltage	36	V
P _{tot}	Total Power Dissipation at T _{amb} = 70°C	400	mW
T _{stg} , T _j	Storage and Junction Temperature	-40 to 150	°C

ELECTRICAL CHARACTERISTICS

$V_{CC} = 15V$, $T_{amb} = 25^{\circ}C$ (unless otherwise specified) (refer to the test circuits)

Symbol	Parameter	Min.	Typ.	Max.	Unit
V_{CC}	Supply Voltage (*)	3		36	V
I_{CC}	Supply Current (*)		0.8	2	mA
I_{ib}	Input Bias Current		150	500	nA
V_{io}	Input Offset Voltage $R_s \leq 10k\Omega$		1	5	mV
I_{io}	Input Offset Current		10	50	nA
A_{vd}	Open Loop Voltage Gain $V_{CC} = 15V$ $V_{CC} = 4.5V$ f = 333Hz f = 1kHz f = 10kHz f = 1kHz		80 70 50 70		dB
V_{OPP}	Output Voltage Swing (f = 1kHz, $R_L = 600\Omega$) (*) $V_{CC} = 15V$ $V_{CC} = 4.5V$		13 2.5		V
GBP	Gain-bandwidth Product f = 20kHz	1.5	2.5		MHz
FBP	Power Bandwidth (*) $V_o = 5V_{PP}$, THD = 1%	40	70		kHz
SR	Slew Rate (*)	1	1.6		V/ μ s
THD	Distortion ($V_o = 2V$, $A_v = 20dB$) (*) f = 1kHz f = 10kHz		0.03 0.08		%
e_n	Equivalent Input Noise Voltage (**) Curve A B = 22Hz to 22kHz f = 1kHz		1 1.1 1.5 1.3 1.5 2 9	1.4	μ V nV \sqrt{Hz}
V_{O1}/V_{O2}	Channel Separation (**) f = 1kHz		100		dB
SVR	Supply Voltage Rejection Ratio(**) f = 100Hz		80		dB

(*) Test circuit of figure 1

(**) Test circuit of figure 2

TYPICAL APPLICATION

STEREO PREAMPLIFIER FOR CASSETTE PLAYERS

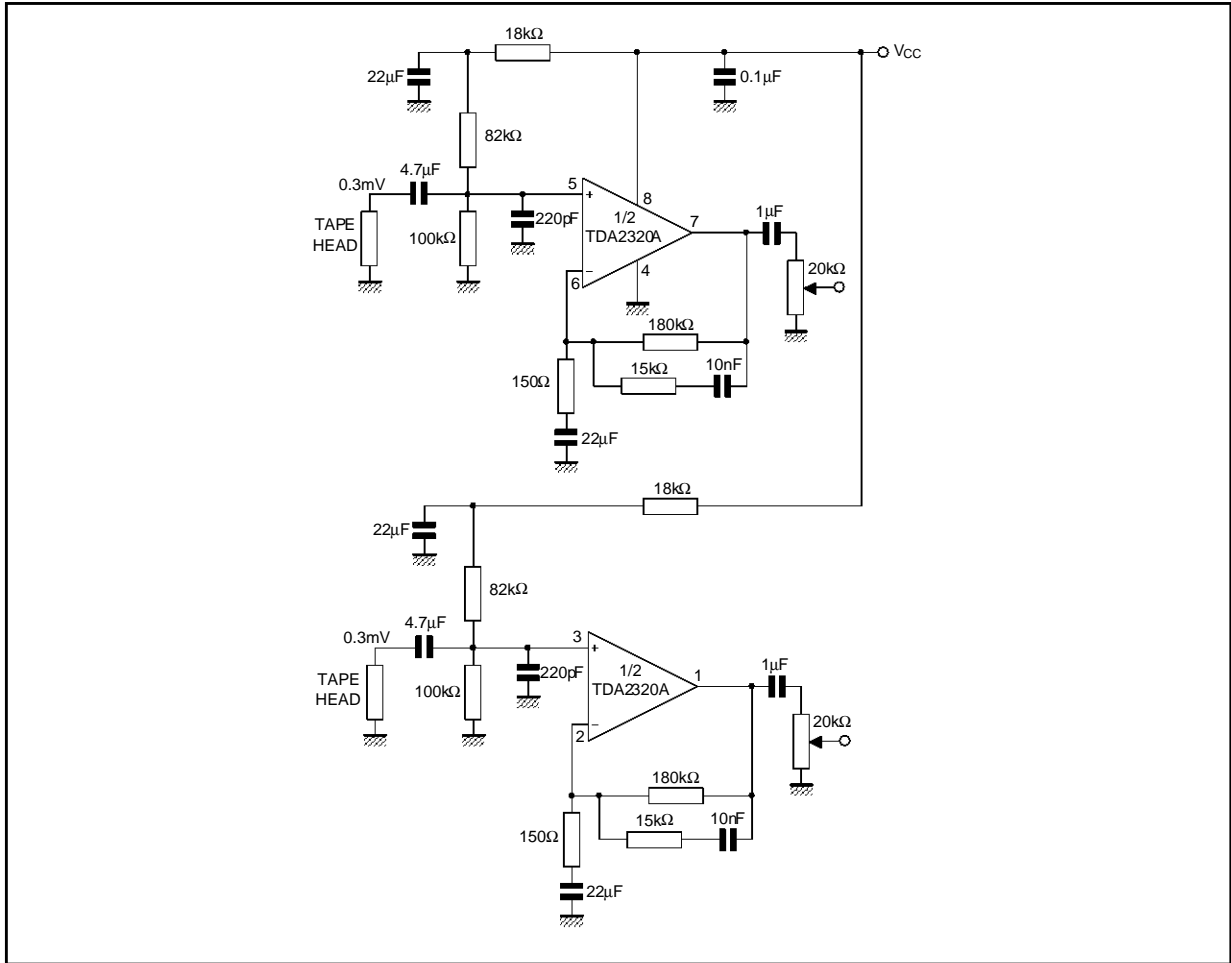

TEST CIRCUITS

Figure 1

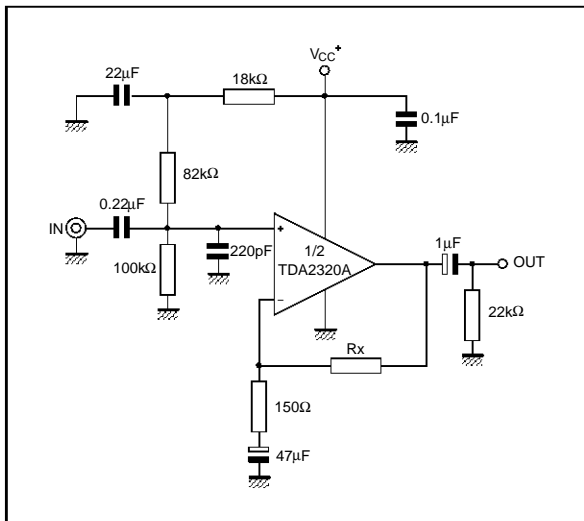

Figure 2

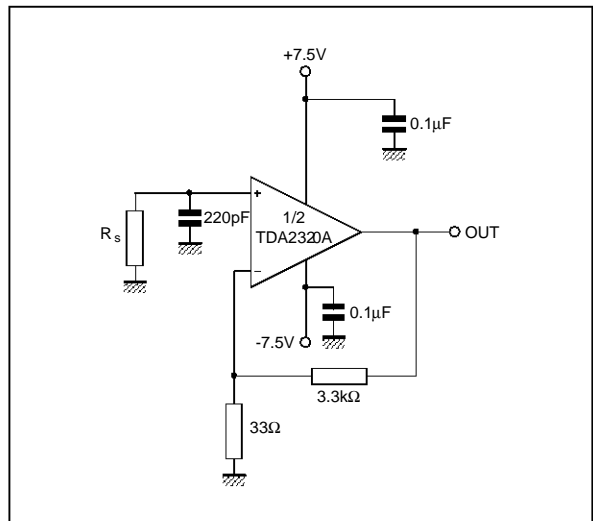

Figure 3 : Supply Current versus Supply Voltage

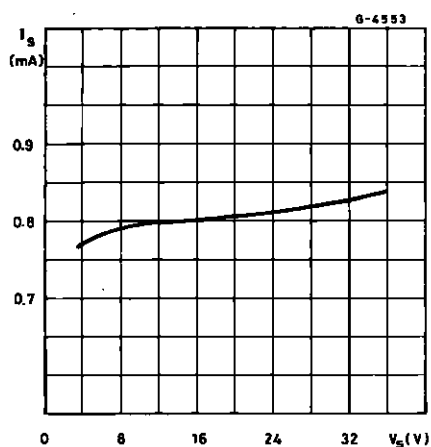

Figure 4 : Supply Current versus Ambient Temperature

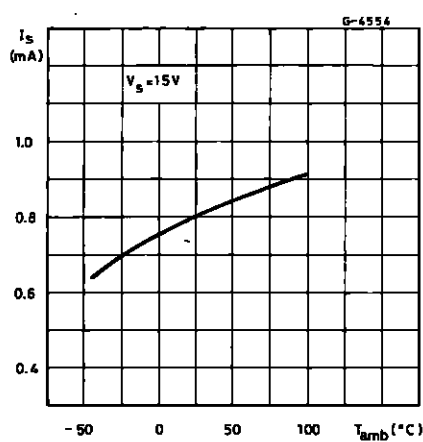

Figure 5 : Output Voltage Swing versus Load Resistance

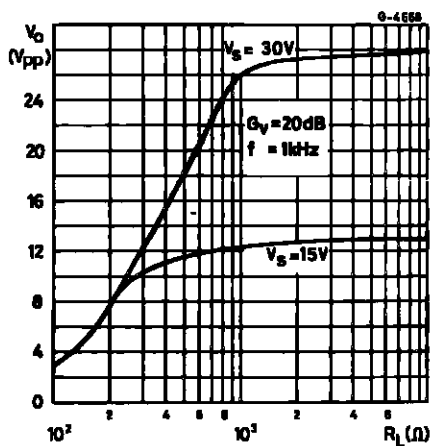

Figure 6 : Power Bandwidth

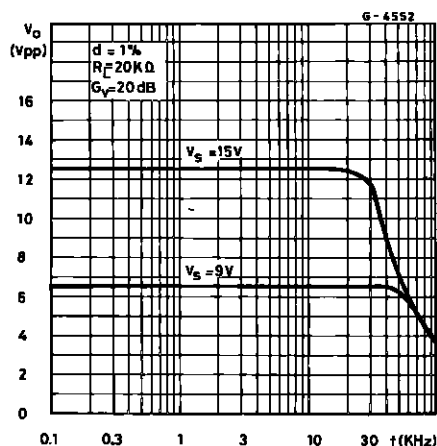

Figure 7 : Total Harmonic Distortion versus Output Voltage

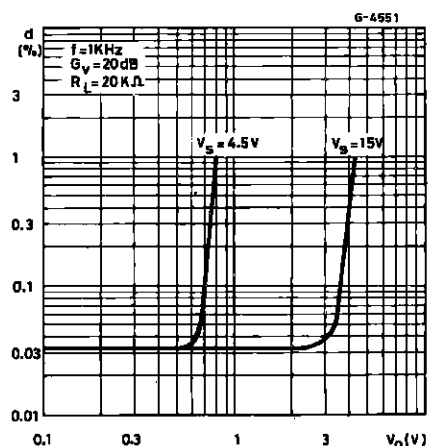

Figure 8 : Total Input Noise versus Source Resistance

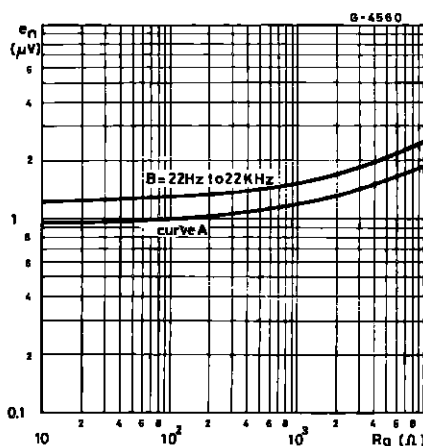

Figure 9 : Noise Density versus Frequency

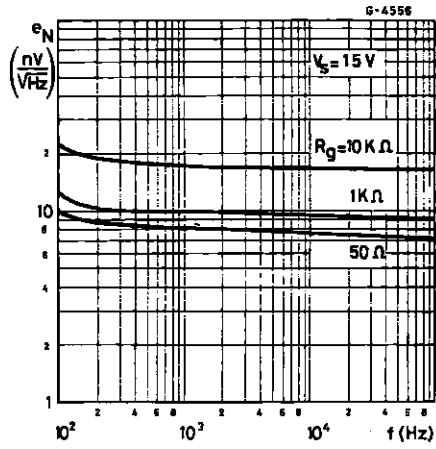

Figure 10 :RIAA Preamplifier Response

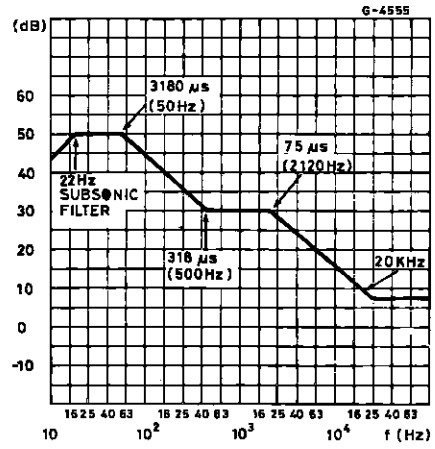
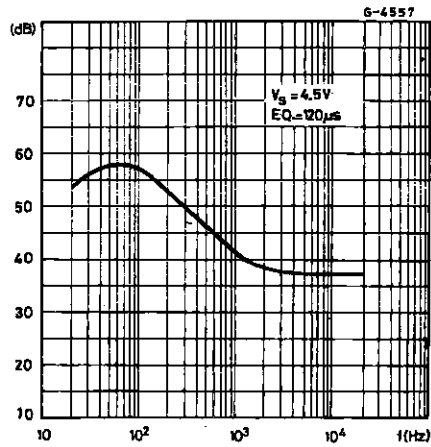

Figure 11 :Tape Preamplifier Frequency



APPLICATION INFORMATION

Figure 12 :Stereo RIAA Preamplifier

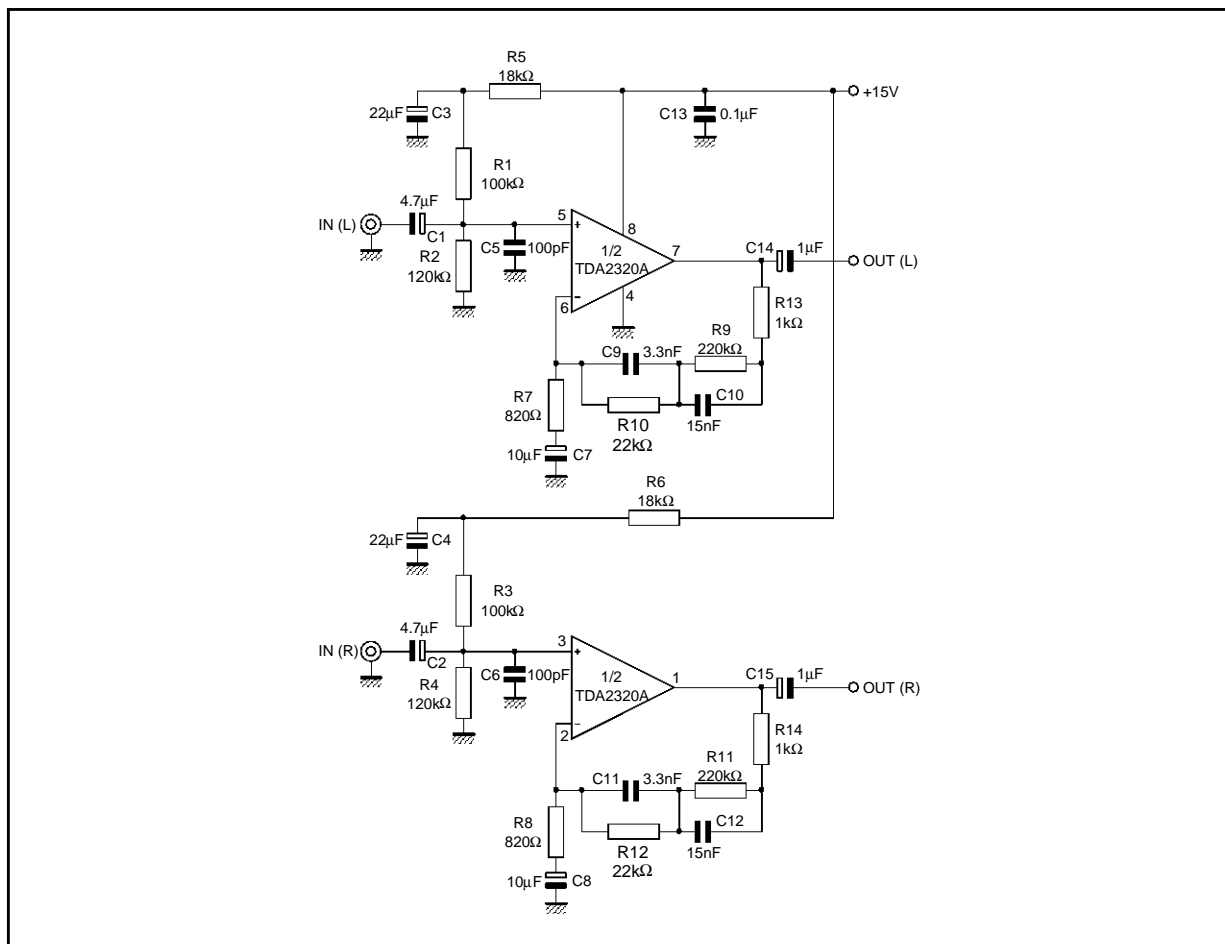

Figure 13 :P.C. Board and Components layout of the Circuit of figure 12

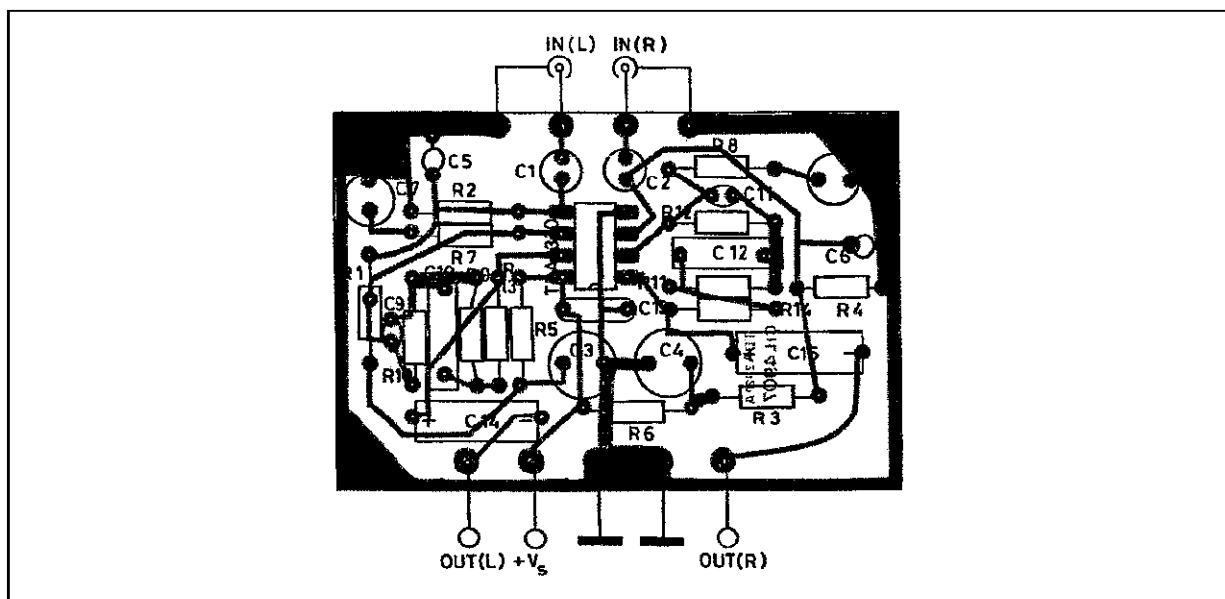

Figure 14 : Second Order 2kHz Butterworth Crossover Filter for Hi-Fi Active Boxes

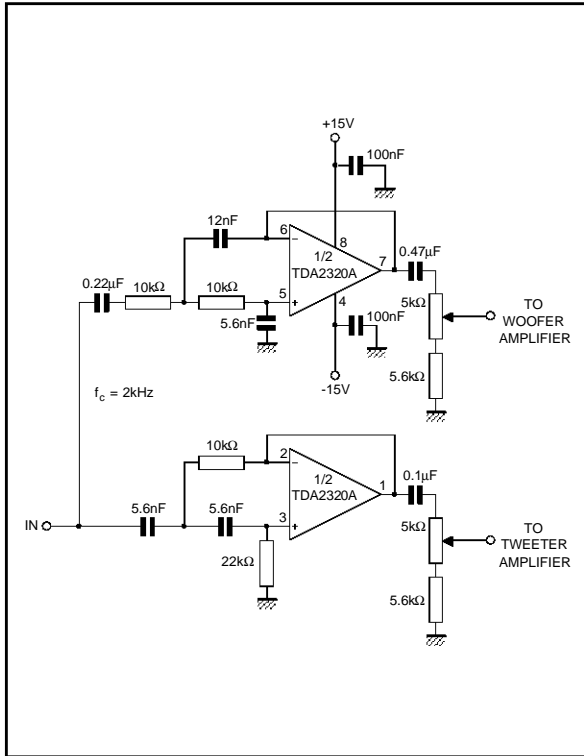

Figure 16 : Frequency Response (circuit of figure 14)

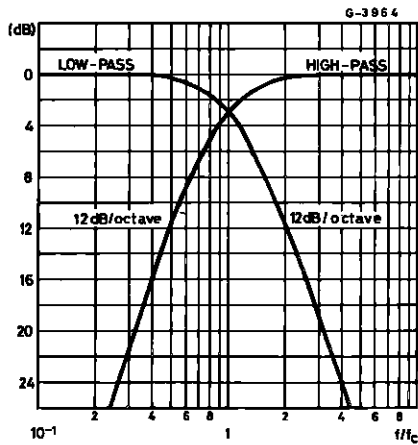

Figure 15 : Third Order 2.8kHz Bessel Crossover Filter for Hi-Fi Active Boxes

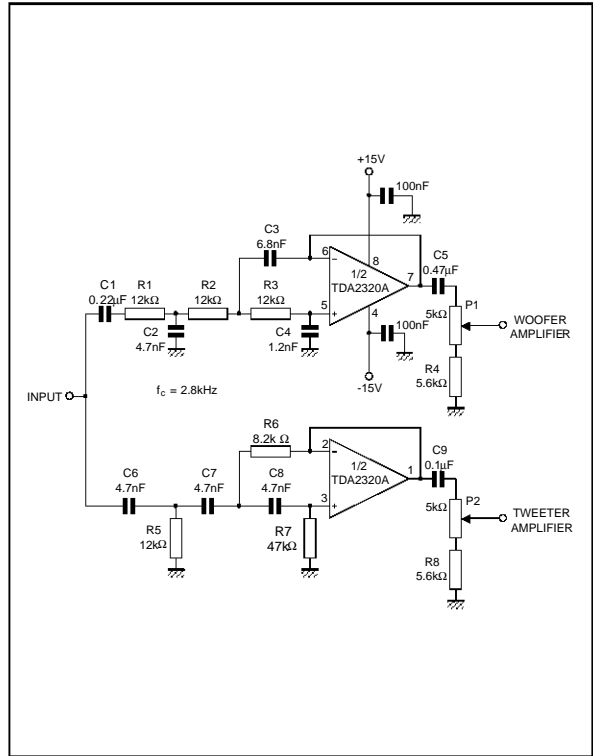

Figure 17 : Frequency Response (circuit of figure 15)

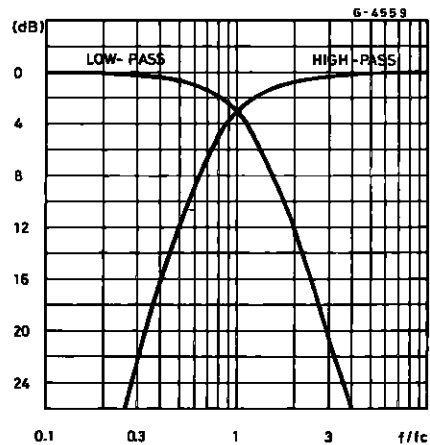

Figure 18 :200Hz to 2kHz Active Bandpass Filter for Midrange Speakers

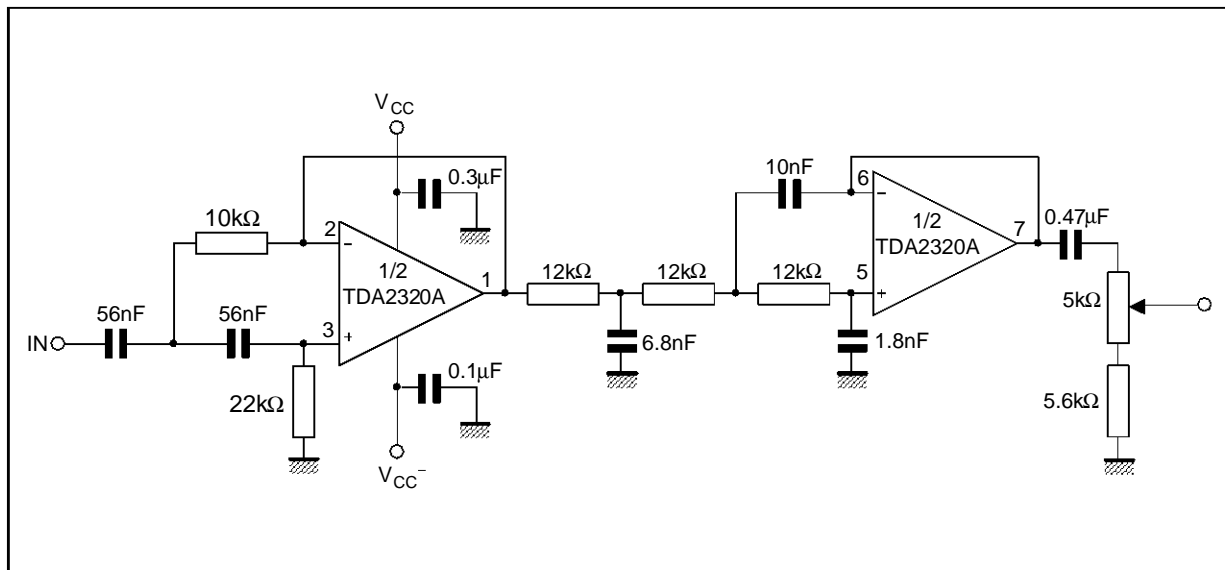

Figure 19 :Subsonic Filter

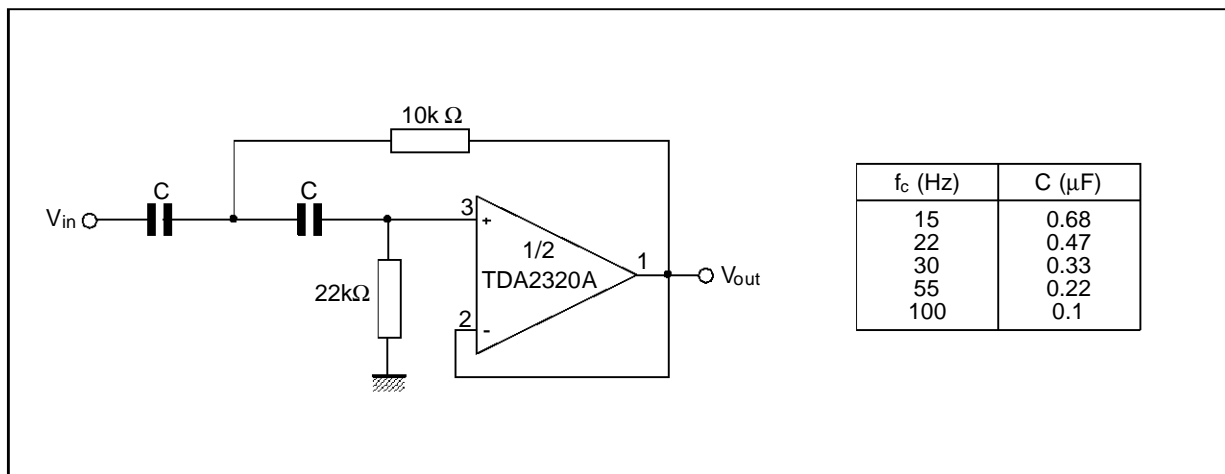

Figure 20 :High-cut Filter

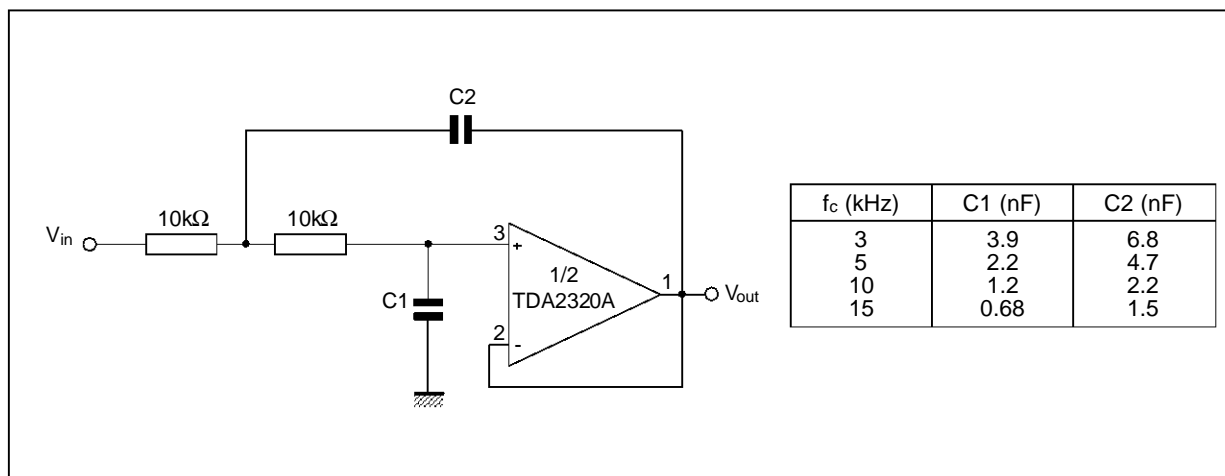
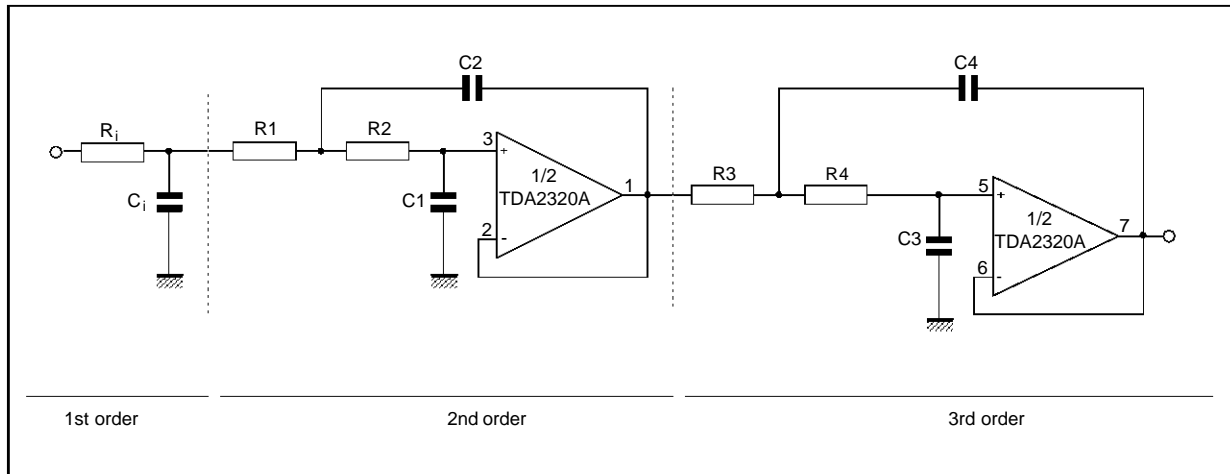

Figure 21 :Fifth Order 3.4kHz Low-pass Butterworth Filter



For $f_c = 3.4\text{kHz}$ and $R_i = R_1 = R_2 = R_3 = R_4 = 10\text{k}\Omega$, we obtain :

$$C_1 = 1.354 \cdot \frac{1}{R} \cdot \frac{1}{2\pi f_c} = 6.33\text{nF}$$

$$C_3 = 0.309 \cdot \frac{1}{R} \cdot \frac{1}{2\pi f_c} = 1.45\text{nF}$$

$$C_1 = 0.421 \cdot \frac{1}{R} \cdot \frac{1}{2\pi f_c} = 1.97\text{nF}$$

$$C_4 = 3.325 \cdot \frac{1}{R} \cdot \frac{1}{2\pi f_c} = 15.14\text{nF}$$

$$C_2 = 1.753 \cdot \frac{1}{R} \cdot \frac{1}{2\pi f_c} = 8.20\text{nF}$$

The attenuation of the filter is 30dB at 6.8kHz and better than 60dB at 15kHz.

Figure 22 :Sixth-pole 355Hz Low-pass Filter (Chebychev type)

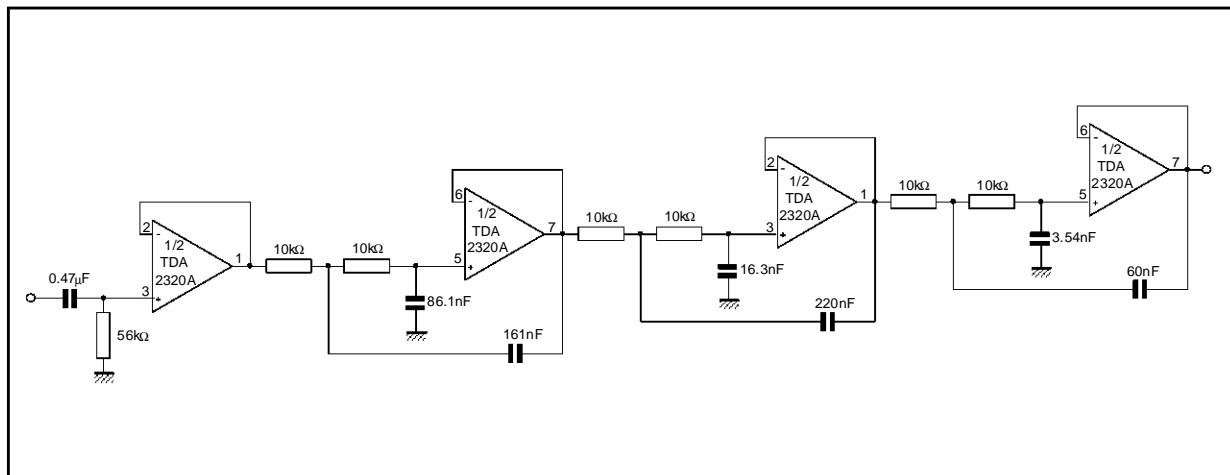

This is a 6-pole Chebychev type with $\pm 0.25\text{dB}$ ripple in the passband. A decoupling stage is used to avoid the influence of the input impedance of the filter's characteristics.

The attenuation is about 55dB at 710Hz and reaches 80dB at 1065Hz. The in band attenuation is limited in practice to the $\pm 0.25\text{dB}$ ripple and does not exceed $1/2\text{dB}$ at $0.9f_c$.

Figure 23 : Three Band Tone Control

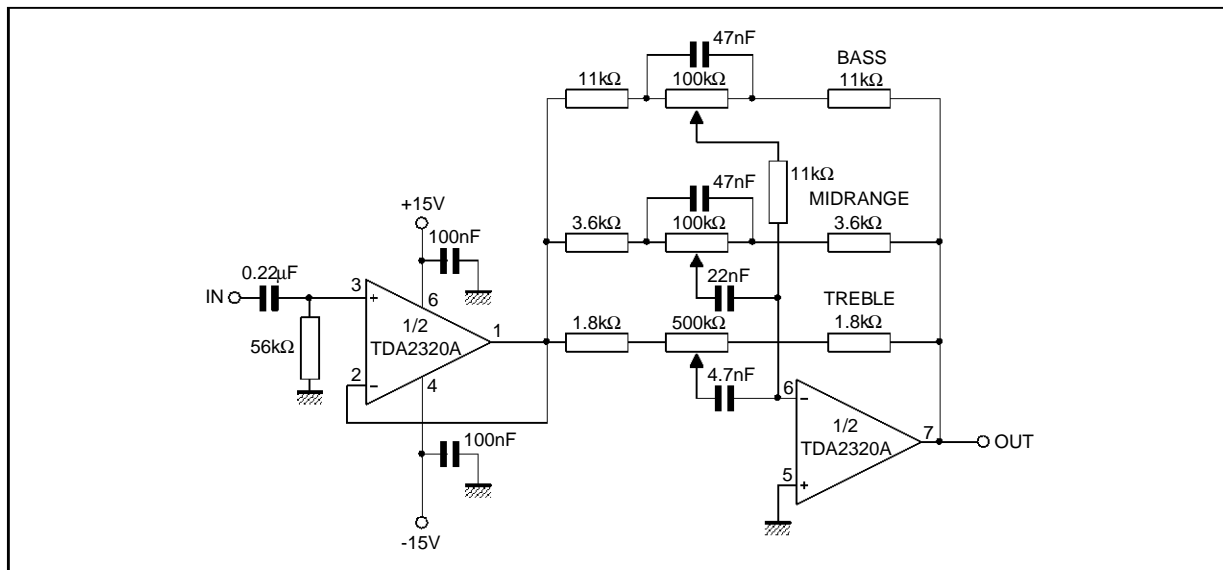
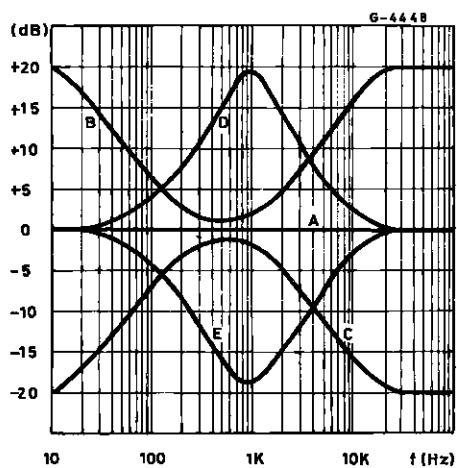
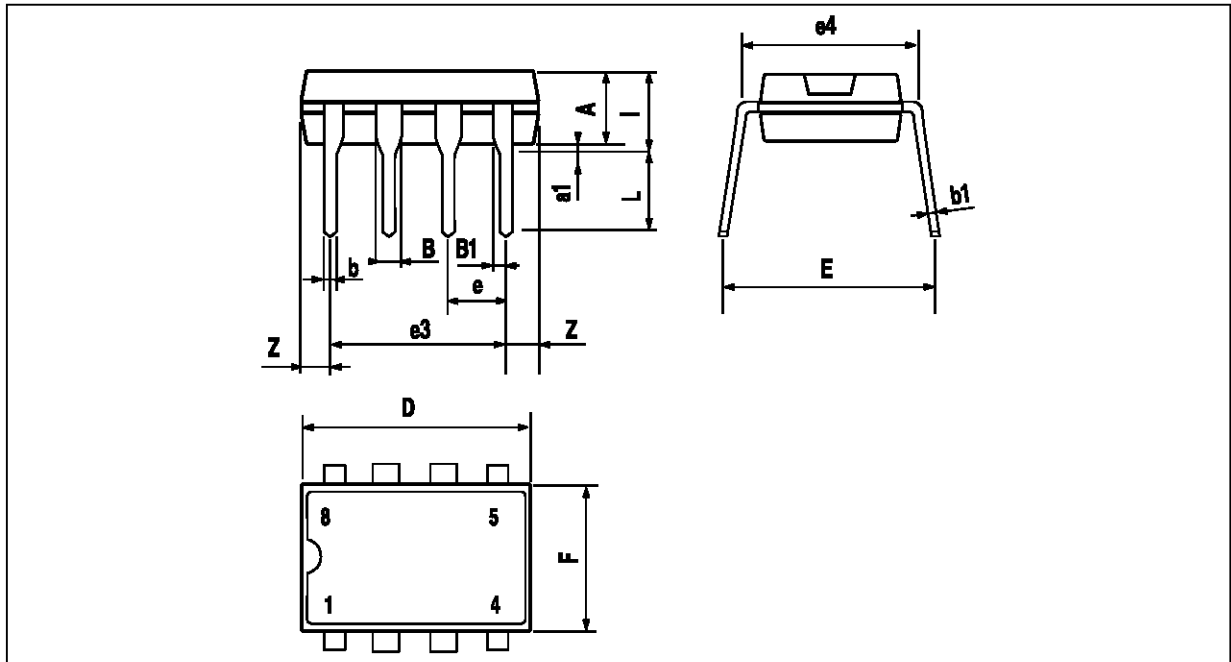

Figure 24 :Frequency Response of the Circuit of figure 23



- A : all controls flat
- B : bass & treble boost, mid flat
- C : bass & treble cut, mid flat
- D : mid boost, bass & treble flat
- E : mid cut, bass treble flat

PACKAGE MECHANICAL DATA
8 PINS -PLASTIC DIP



PM-DIP8.EPS

Dimensions	Millimeters			Inches		
	Min.	Typ.	Max.	Min.	Typ.	Max.
A		3.32			0.131	
a1	0.51			0.020		
B	1.15		1.65	0.045		0.065
b	0.356		0.55	0.014		0.022
b1	0.204		0.304	0.008		0.012
D			10.92			0.430
E	7.95		9.75	0.313		0.384
e		2.54			0.100	
e3		7.62			0.300	
e4		7.62			0.300	
F			6.6			0.260
i			5.08			0.200
L	3.18		3.81	0.125		0.150
Z			1.52			0.060

DIP8.TBL

Information furnished is believed to be accurate and reliable. However, SGS-THOMSON Microelectronics assumes no responsibility for the consequences of use of such information nor for any infringement of patents or other rights of third parties which may result from its use. No license is granted by implication or otherwise under any patent or patent rights of SGS-THOMSON Microelectronics. Specifications mentioned in this publication are subject to change without notice. This publication supersedes and replaces all information previously supplied. SGS-THOMSON Microelectronics products are not authorized for use as critical components in life support devices or systems without express written approval of SGS-THOMSON Microelectronics.

© 1997 SGS-THOMSON Microelectronics – Printed in Italy – All Rights Reserved

SGS-THOMSON Microelectronics GROUP OF COMPANIES
Australia - Brazil - Canada - China - France - Germany - Hong Kong - Italy - Japan - Korea - Malaysia - Malta - Morocco
The Netherlands - Singapore - Spain - Sweden - Switzerland - Taiwan - Thailand - United Kingdom - U.S.A.

ORDER CODE :