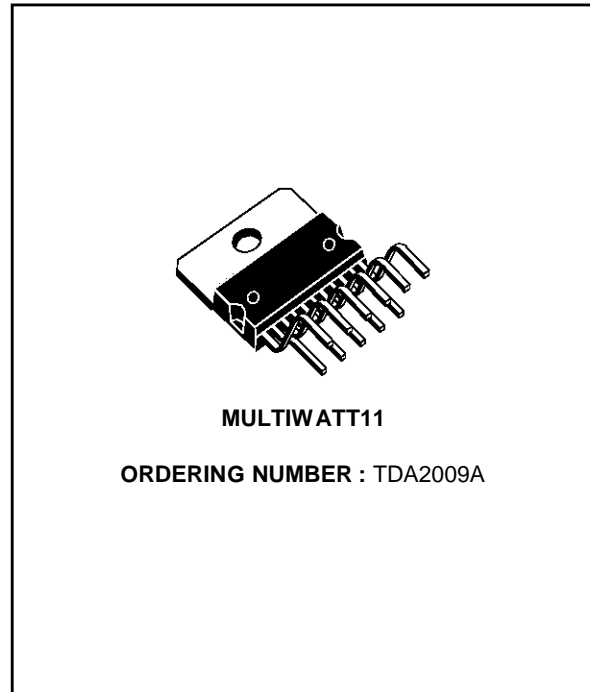


**10 +10W STEREO AMPLIFIER**

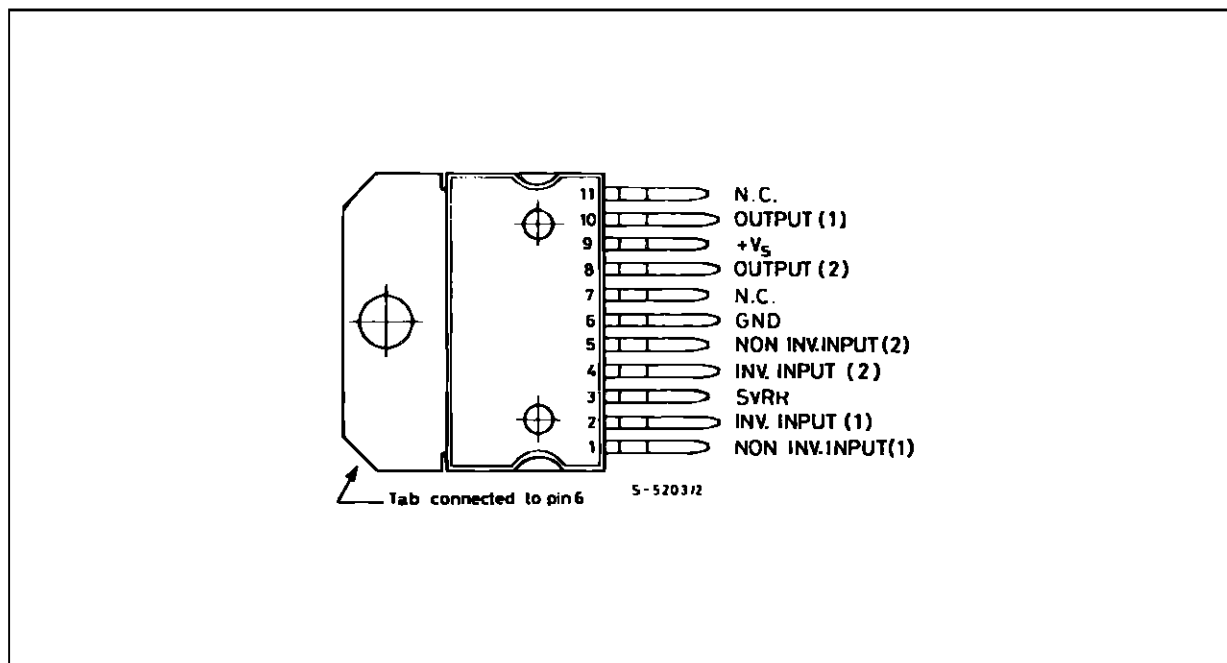
- HIGH OUTPUT POWER  
(10 + 10W Min. @ D = 1%)
- HIGH CURRENT CAPABILITY (UP TO 3.5A)
- AC SHORT CIRCUIT PROTECTION
- THERMAL OVERLOAD PROTECTION
- SPACE AND COST SAVING : VERY LOW NUMBER OF EXTERNAL COMPONENTS AND SIMPLE MOUNTING THANKS TO THE MULTIWATT<sup>®</sup> PACKAGE.



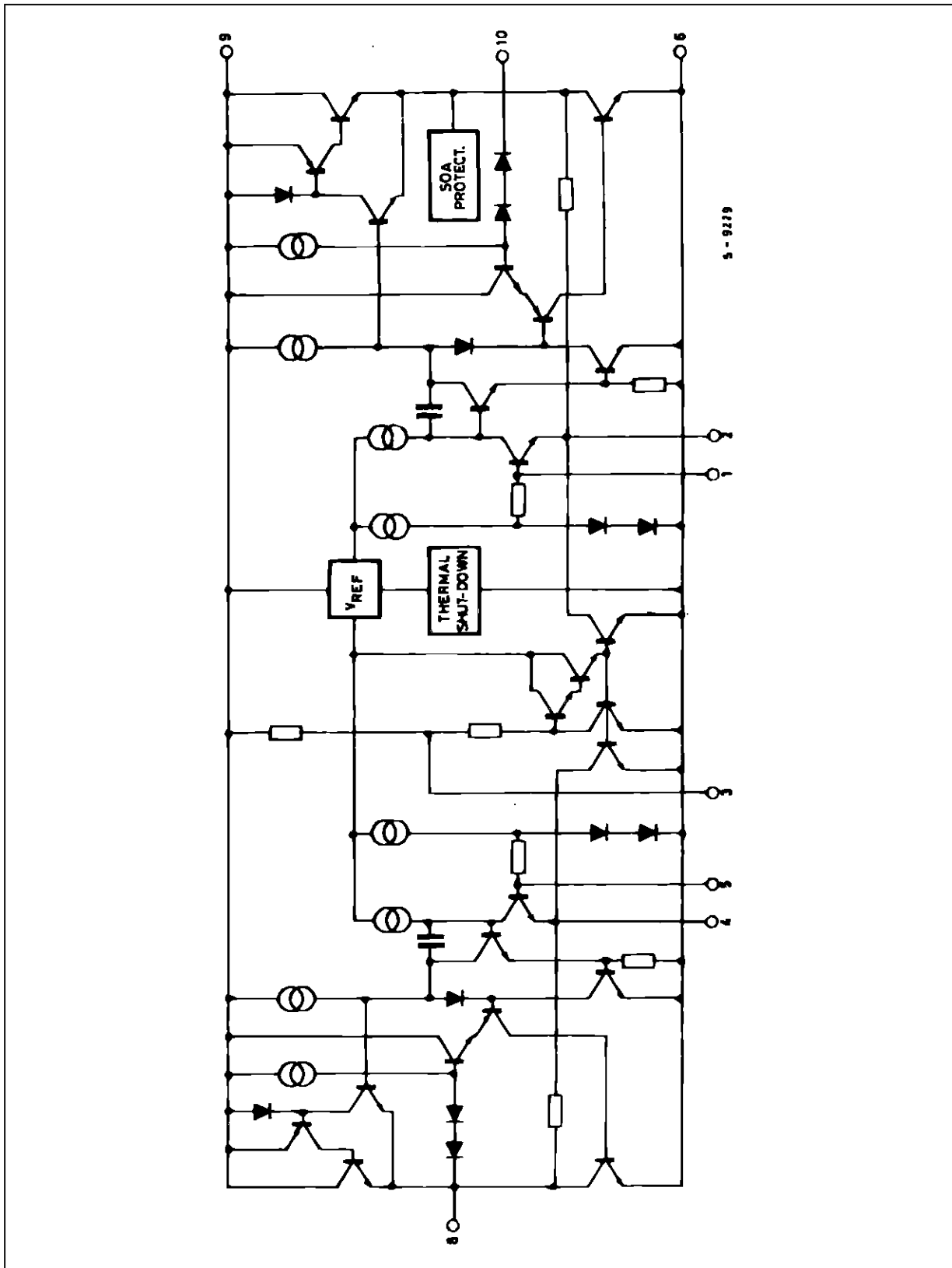
**DESCRIPTION**

The TDA2009A is class AB dual Hi-Fi Audio power amplifier assembled in Multiwatt<sup>®</sup> package, specially designed for high quality stereo application as Hi-Fi and music centers.

**PIN CONNECTION**



SCHEMATIC DIAGRAM



**ABSOLUTE MAXIMUM RATINGS**

Symbol	Parameter	Value	Unit
$V_s$	Supply Voltage	28	V
$I_o$	Output Peak Current (repetitive $f \geq 20$ Hz)	3.5	A
$I_o$	Output Peak Current (non repetitive, $t = 100 \mu s$ )	4.5	A
$P_{tot}$	Power Dissipation at $T_{case} = 90$ °C	20	W
$T_{stg}, T_j$	Storage and Junction Temperature	- 40, + 150	°C

**THERMAL DATA**

Symbol	Parameter	Value	Unit
$R_{thj-case}$	Thermal Resistance Junction-case Max.	3	°C/W

**ELECTRICAL CHARACTERISTICS**

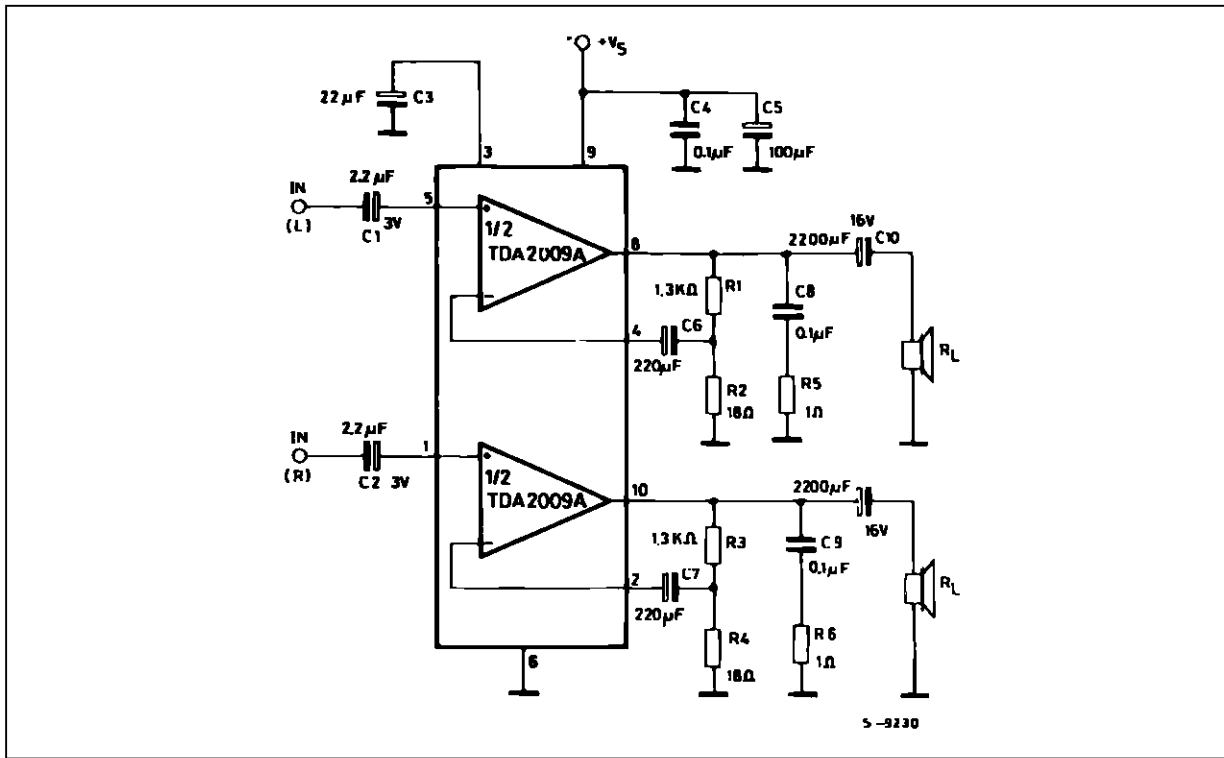
(refer to the stereo application circuit,  $T_{amb} = 25$ °C,  $V_s = 24$ V,  $G_v = 36$ dB, unless otherwise specified)

Symbol	Parameter	Test Conditions	Min.	Typ.	Max.	Unit
$V_s$	Supply Voltage		8		28	V
$V_o$	Quiescent Output Voltage	$V_s = 24$ V		11.5		V
$I_d$	Total Quiescent Drain Current	$V_s = 24$ V		60	120	mA
$P_o$	Output Power (each channel)	$d = 1\%$ , $V_s = 24$ V, $f = 1$ kHz $R_L = 4\Omega$ $R_L = 8\Omega$ $f = 40$ Hz to 12.5kHz $R_L = 4\Omega$ $R_L = 8\Omega$ $V_s = 18$ V, $f = 1$ kHz $R_L = 4\Omega$ $R_L = 8\Omega$	10 5	12.5 7		W W W W W W
$d$	Distortion (each channel)	$f = 1$ kHz, $V_s = 24$ V $P_o = 0.1$ to 7W $R_L = 4\Omega$ $P_o = 0.1$ to 3.5W $R_L = 8\Omega$ $V_s = 18$ V $P_o = 0.1$ to 5W $R_L = 4\Omega$ $P_o = 0.1$ to 2.5W $R_L = 8\Omega$		0.2 0.1		% % % %
CT	Cross Talk (3)	$R_L = \infty$ , $R_g = 10$ k $\Omega$ $f = 1$ kHz $f = 10$ kHz		60 50		dB
$V_i$	Input Saturation Voltage (rms)		300			mV
$R_i$	Input Resistance	$f = 1$ kHz, Non Inverting Input	70	200		k $\Omega$
$f_L$	Low Frequency Roll off (- 3dB)	$R_L = 4\Omega$		20		Hz
$f_H$	High Frequency Roll off (- 3dB)	$R_L = 4\Omega$		80		kHz
$G_v$	Voltage Gain (closed loop)	$f = 1$ kHz	35.5	36	36.5	dB
$\Delta G_v$	Closed Loop Gain Matching			0.5		dB
$e_N$	Total Input Noise Voltage	$R_g = 10$ k $\Omega$ (1) $R_g = 10$ k $\Omega$ (2)		1.5 2.5	8	$\mu$ V $\mu$ V
SVR	Supply Voltage Rejection (each channel)	$R_g = 10$ k $\Omega$ $f_{ripple} = 100$ Hz, $V_{ripple} = 0.5$ V		55		dB
$T_J$	Thermal Shut-down Junction Temperature			145		°C

- Notes : 1. Curve A  
2. 22Hz to 22kHz

# TDA2009A

**Figure 1** : Test and Application Circuit ( $G_v = 36\text{dB}$ )



**Figure 2** : P.C. board and component layout of the fig. 1

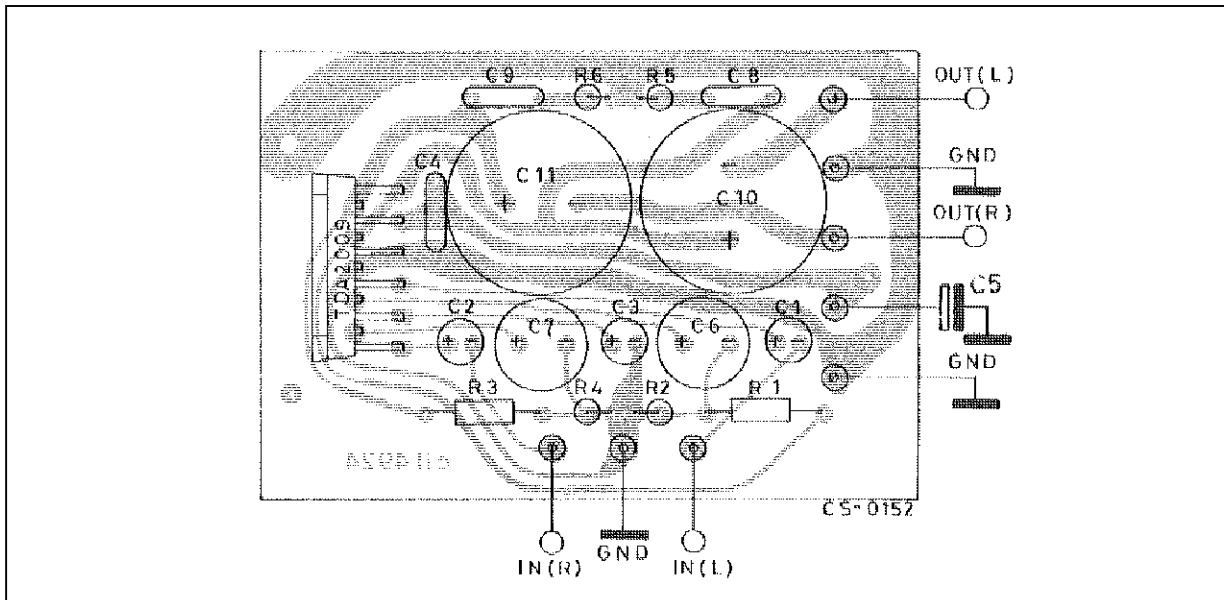


Figure 3 : Output Power versus Supply Voltage

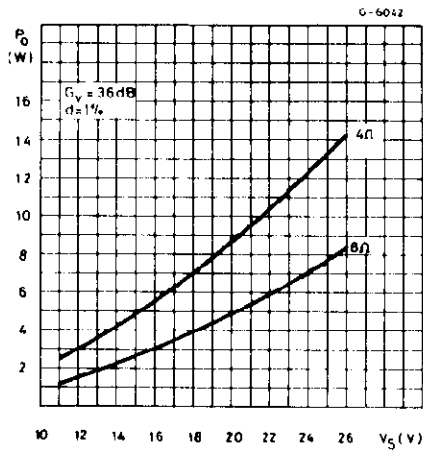


Figure 4 : Output Power versus Supply Voltage

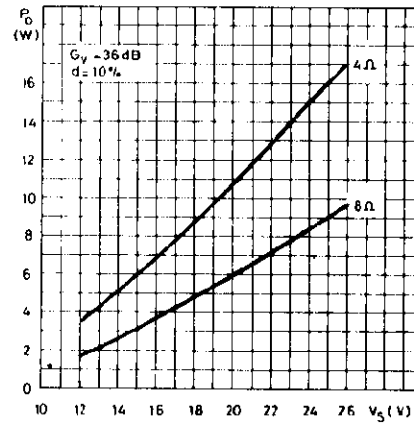


Figure 5 : Distortion versus Output Power

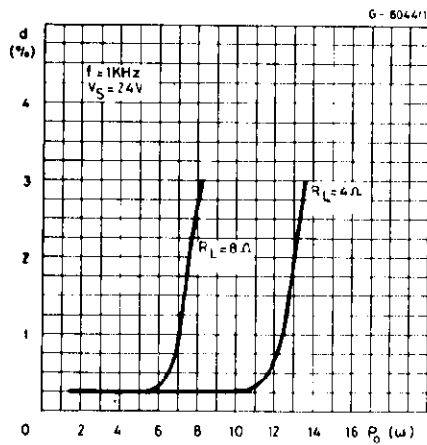


Figure 6 : Distortion versus Frequency

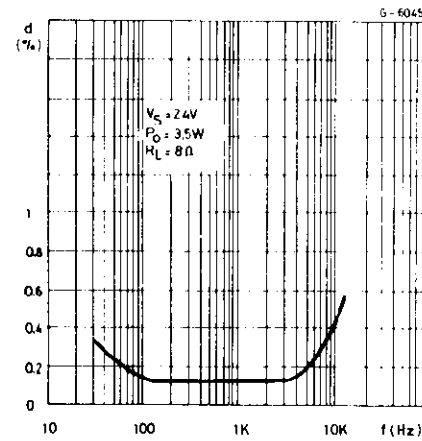


Figure 7 : Distortion versus Frequency

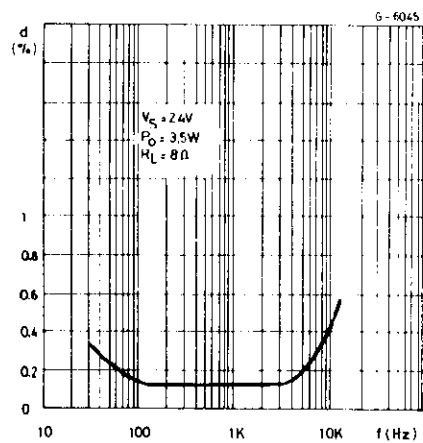
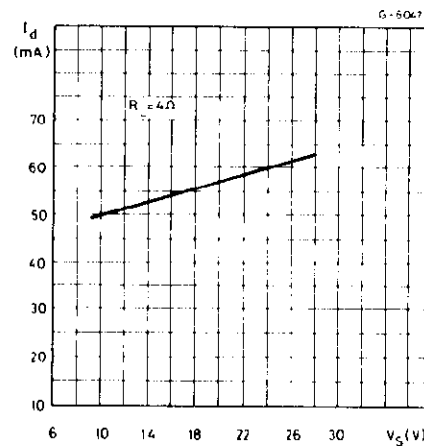
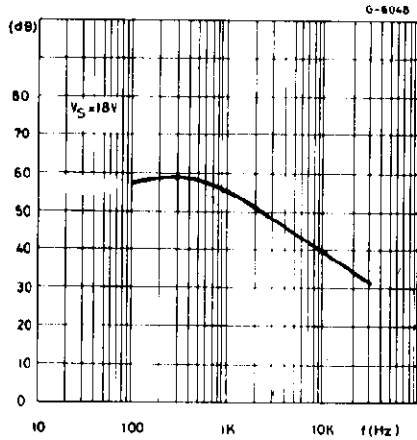


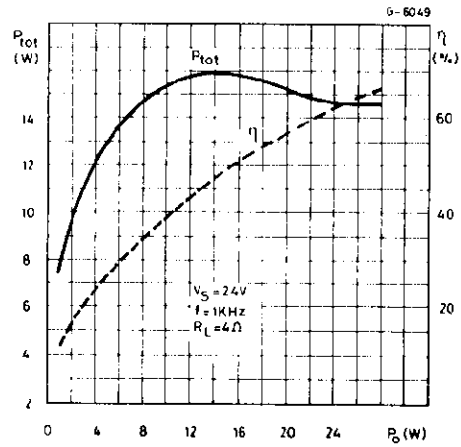
Figure 8 : Quiescent Current versus Supply Voltage



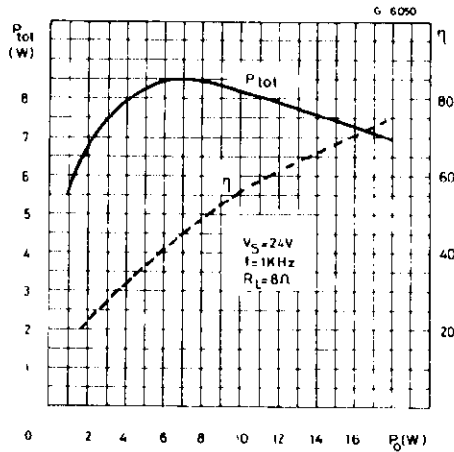
**Figure 9 :** Supply Voltage Rejection versus Frequency



**Figure 10 :** Total Power Dissipation and Efficiency versus Output Power



**Figure 11 :** Total Power Dissipation and Efficiency versus Output Power



**APPLICATION INFORMATION**

**Figure 12 :** Example of Muting Circuit

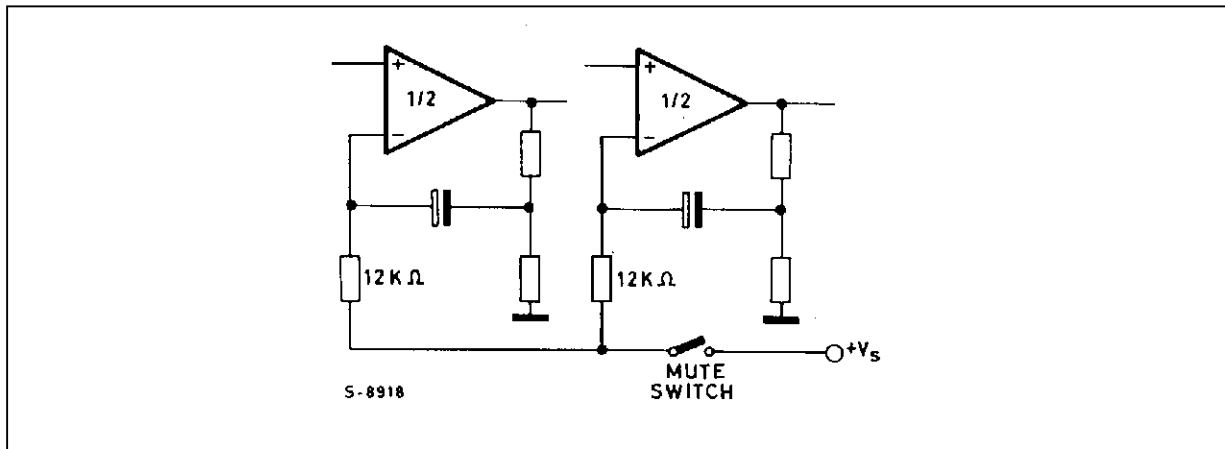


Figure 13 : 10W +10W Stereo Amplifier with Tone Balance and Loudness Control

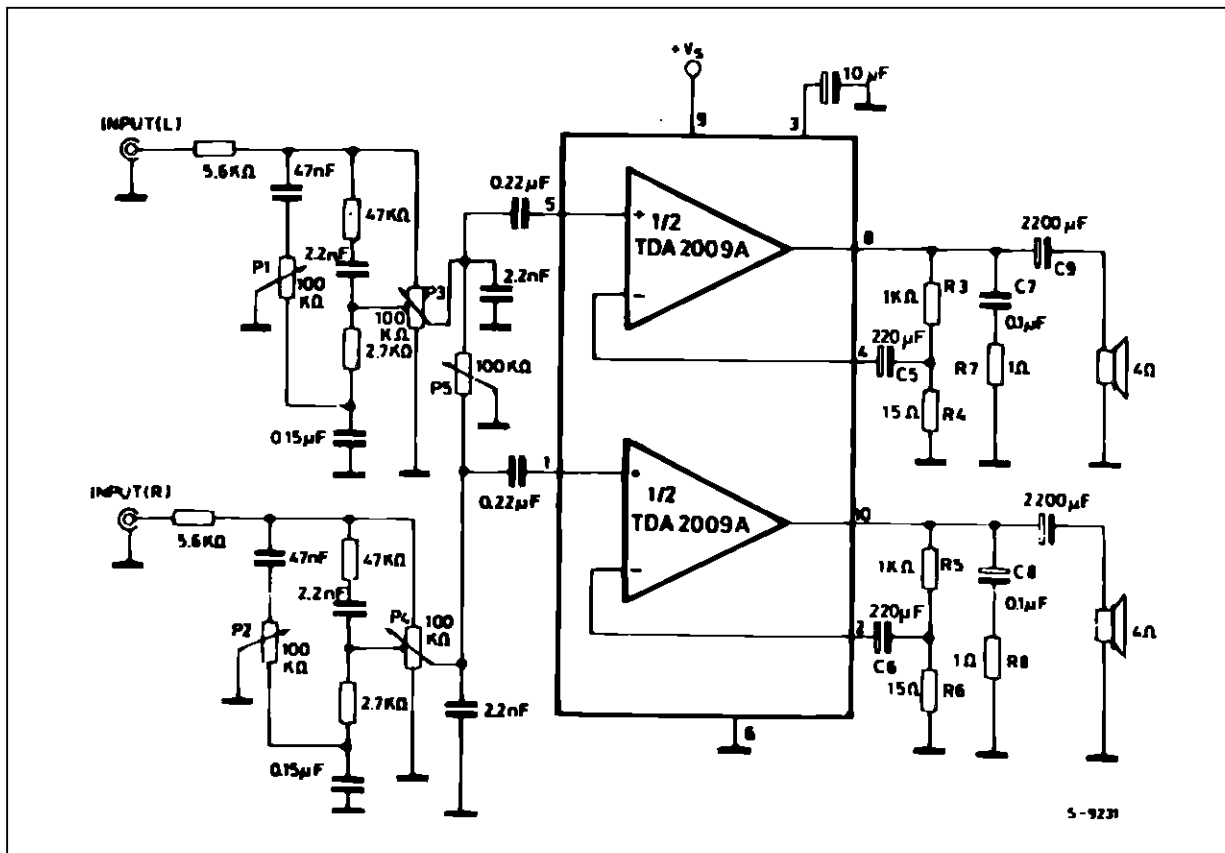
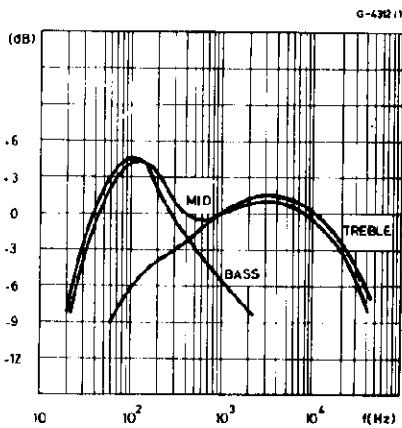
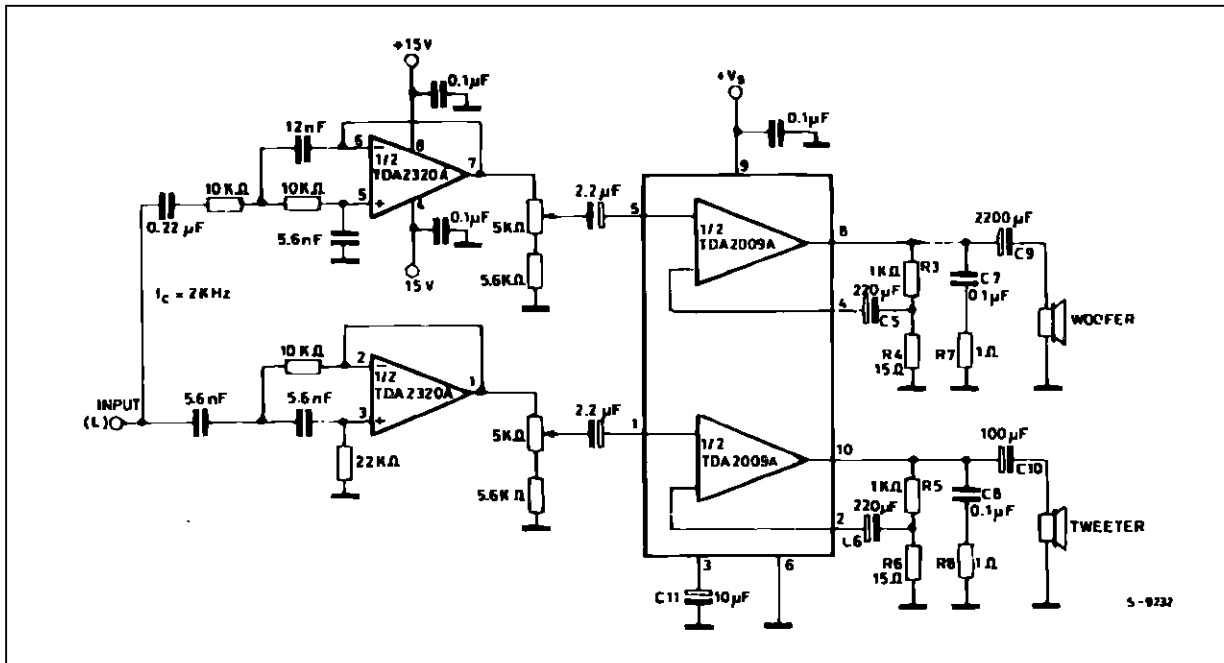


Figure 14 : Tone Control Response  
(circuit of Figure 13)



# TDA2009A

**Figure 15 :** High Quality 20 + 20W Two Way Amplifier for Stereo Music Center (one channel only)



**Figure 16 :** 18W Bridge Amplifier ( $d = 1\%$ ,  $G_v = 40\text{dB}$ )

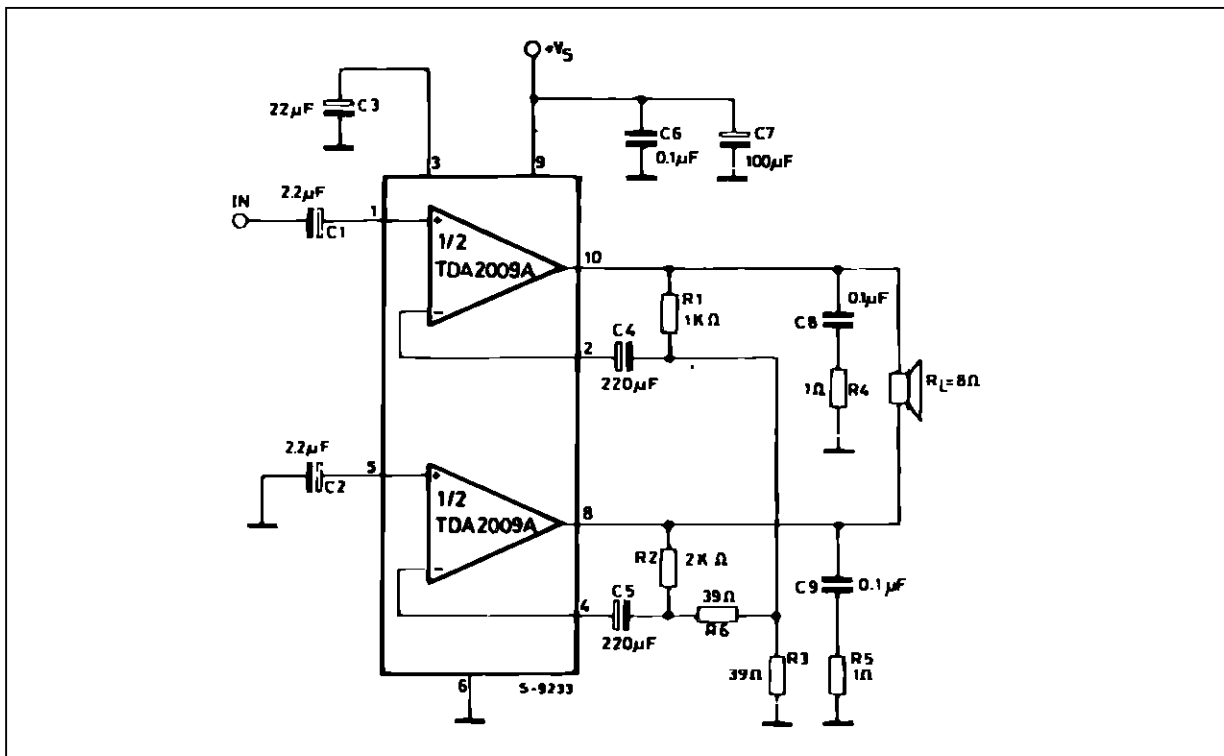
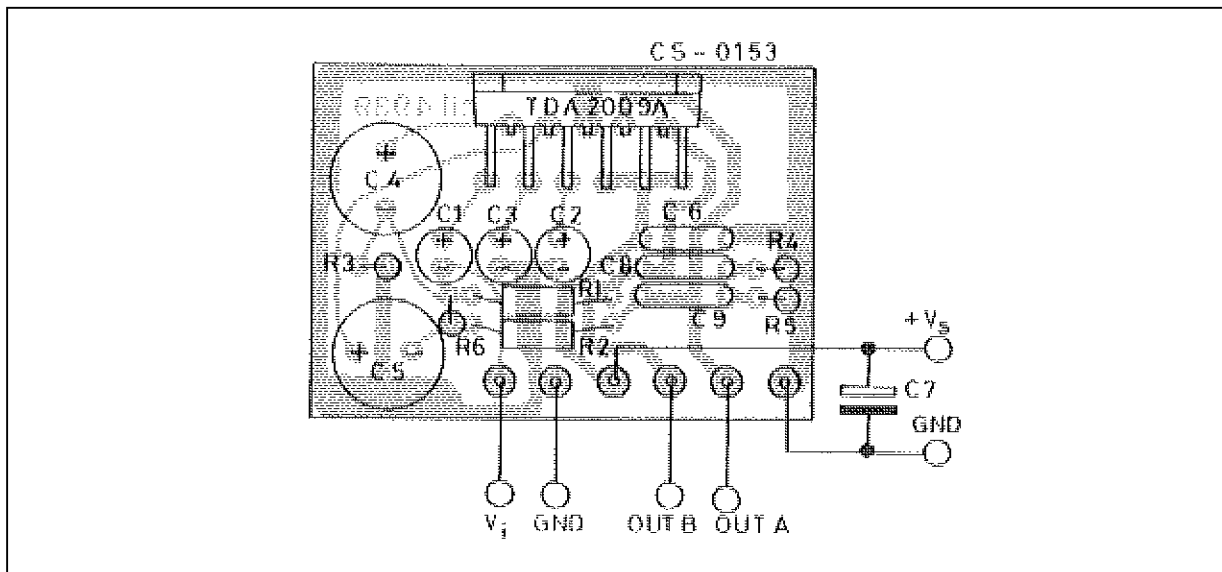




Figure 17 : P.C. BOARD and Components Layout of the Circuit of Figure 16 (1:1 scale)



**APPLICATION SUGGESTION**

The recommended values of the components are those shown on application circuit of fig. 1. Different values can be used ; the following table can help the designer.

Component	Recommended Value	Purpose	Larger than	Smaller than
R1, R3	1.2kΩ	Close Loop Gain Setting (1)	Increase of Gain	Decrease of Gain
R2, R4	18kΩ		Decrease of Gain	Increase of Gain
R5, R6	1Ω	Frequency Stability	Danger of Oscillation at High Frequency with Inductive Load	
C1, C2	2.2μF	Input DC Decoupling	High Turn-on Delay	High Turn-on Pop. Higher Low Frequency Cut-off. Increase of Noise
C3	22μF	Ripple Rejection	Better SVR. Increase of the Switch-on Time	Degradation of SVR
C6, C7	220μF	Feedback Input DC Decoupling		
C8, C9	0.1μF	Frenquency Stability		Danger of Oscillation
C10, C11	1000μF to 2200μF	Output DC Decoupling		Higher Low-frequency Cut-off

(1) The closed loop gain must be higher than 26dB.

**BUILD-IN PROTECTION SYSTEMS**

**THERMAL SHUT-DOWN**

The presence of a thermal limiting circuit offers the following advantages:

- 1) an averload on the output (even if it is permanent), or an excessive ambient temperature can be easily withstood.
- 2) the heatsink can have a smaller factor of safety compared with that of a conventional circuit. There is no device damage in the case of excessive junction temperature : all that happens is that  $P_o$  (and therefore  $P_{tot}$ ) and  $I_o$  are reduced.

The maximum allowable power dissipation depends upon the size of the external heatsink (i.e. its thermal resistance); Figure 18 shows this dissippable power as a function of ambient temperature for different thermal resistance.

Short circuit (AC Conditions). The TDA2009A can withstand an accidental short circuit from the output and ground made by a wrong connection during normal play operation.

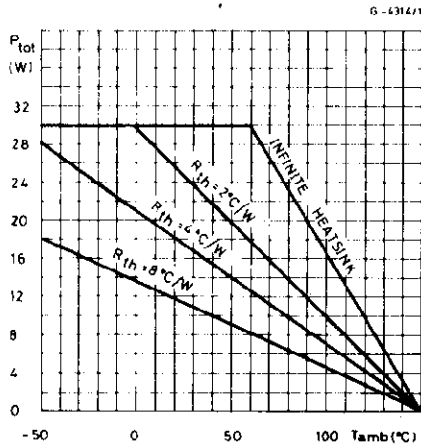
**MOUNTING INSTRUCTIONS**

The power dissipated in the circuit must be removed by adding an external heatsink.

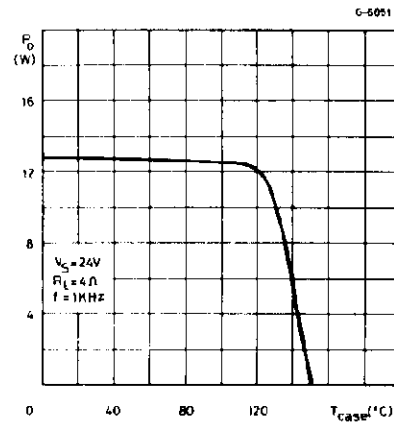
Thanks to the MULTIWATT® package attaching

the heatsink is very simple, a screw or a compression spring (clip) being sufficient. Between the heatsink and the package it is better to insert a layer of silicon grease, to optimize the thermal contact ; no electrical isolation is needed between the two

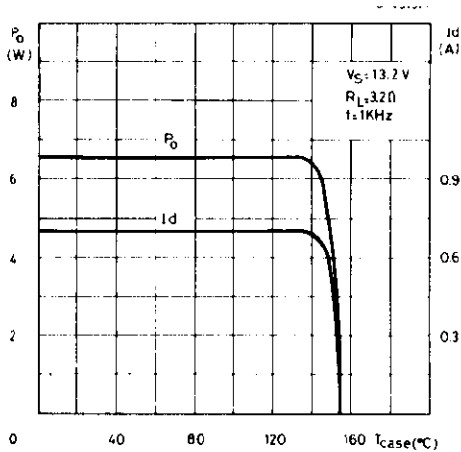
**Figure 18 :** Maximum Allowable Power Dissipation versus Ambient Temperature



**Figure 19 :** Output Power versus Case Temperature

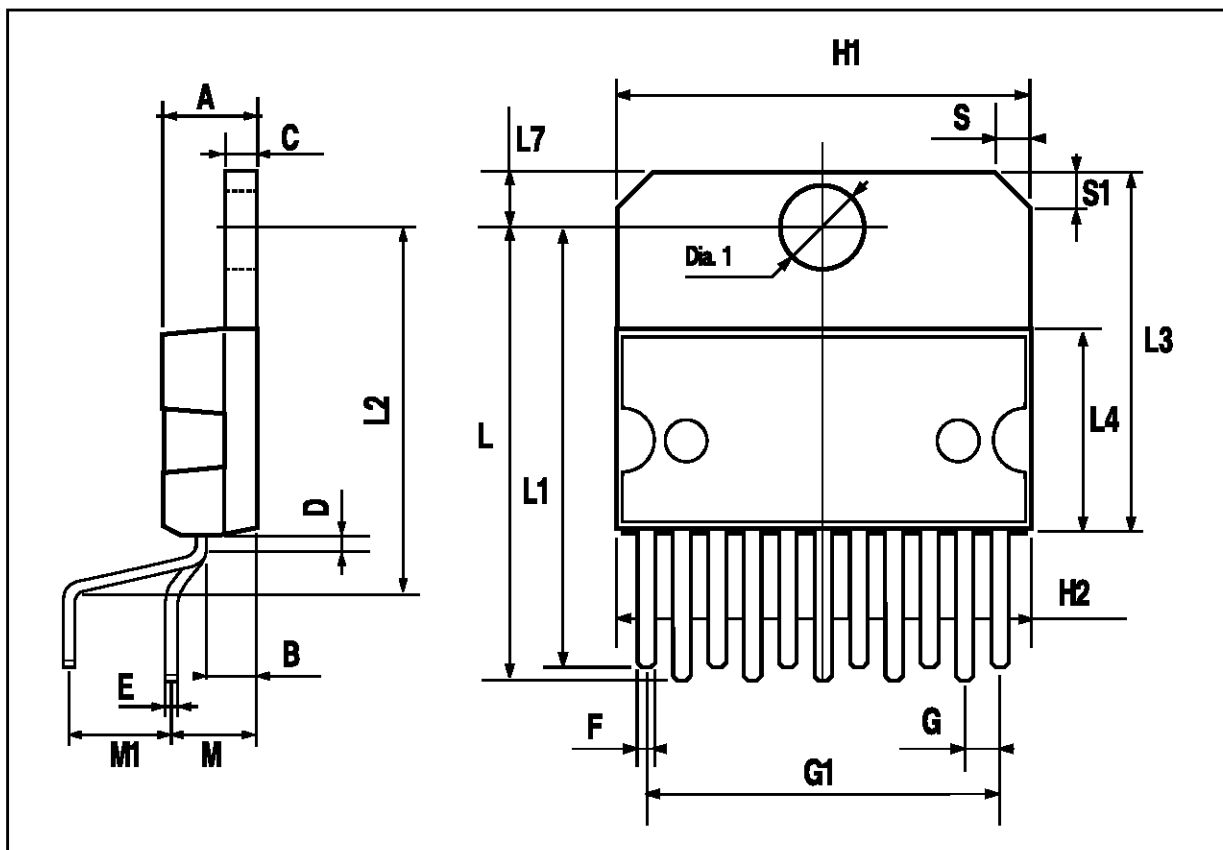


**Figure 20 :** Output Power and Drain Current versus Case Temperature



## MULTIWATT11 PACKAGE MECHANICAL DATA

DIM.	mm			inch		
	MIN.	TYP.	MAX.	MIN.	TYP.	MAX.
A			5			0.197
B			2.65			0.104
C			1.6			0.063
D		1			0.039	
E	0.49		0.55	0.019		0.022
F	0.88		0.95	0.035		0.037
G	1.45	1.7	1.95	0.057	0.067	0.077
G1	16.75	17	17.25	0.659	0.669	0.679
H1	19.6			0.772		
H2			20.2			0.795
L	21.9	22.2	22.5	0.862	0.874	0.886
L1	21.7	22.1	22.5	0.854	0.87	0.886
L2	17.4		18.1	0.685		0.713
L3	17.25	17.5	17.75	0.679	0.689	0.699
L4	10.3	10.7	10.9	0.406	0.421	0.429
L7	2.65		2.9	0.104		0.114
M	4.25	4.55	4.85	0.167	0.179	0.191
M1	4.73	5.08	5.43	0.186	0.200	0.214
S	1.9		2.6	0.075		0.102
S1	1.9		2.6	0.075		0.102
Dia1	3.65		3.85	0.144		0.152



Information furnished is believed to be accurate and reliable. However, SGS-THOMSON Microelectronics assumes no responsibility for the consequences of use of such information nor for any infringement of patents or other rights of third parties which may result from its use. No license is granted by implication or otherwise under any patent or patent rights of SGS-THOMSON Microelectronics. Specifications mentioned in this publication are subject to change without notice. This publication supersedes and replaces all information previously supplied. SGS-THOMSON Microelectronics products are not authorized for use as critical components in life support devices or systems without express written approval of SGS-THOMSON Microelectronics.

© 1994 SGS-THOMSON Microelectronics - All Rights Reserved

SGS-THOMSON Microelectronics GROUP OF COMPANIES

Australia - Brazil - France - Germany - Hong Kong - Italy - Japan - Korea - Malaysia - Malta - Morocco - The Netherlands - Singapore - Spain - Sweden - Switzerland - Taiwan - Thailand - United Kingdom - U.S.A.