

5W AUDIO AMPLIFIER WITH MUTING

DESCRIPTION

The TDA1905 is a monolithic integrated circuit in POWERDIP package, intended for use as low frequency power amplifier in a wide range of applications in radio and TV sets:

- muting facility
- protection against chip over temperature
- very low noise
- high supply voltage rejection
- low "switch-on" noise
- voltage range 4V to 30V

The TDA 1905 is assembled in a new plastic package, the POWERDIP, that offers the same assembly ease, space and cost saving of a normal dual in-line package but with a power dissipation of up to 6W and a thermal resistance of 15°C/W (junction to pins).

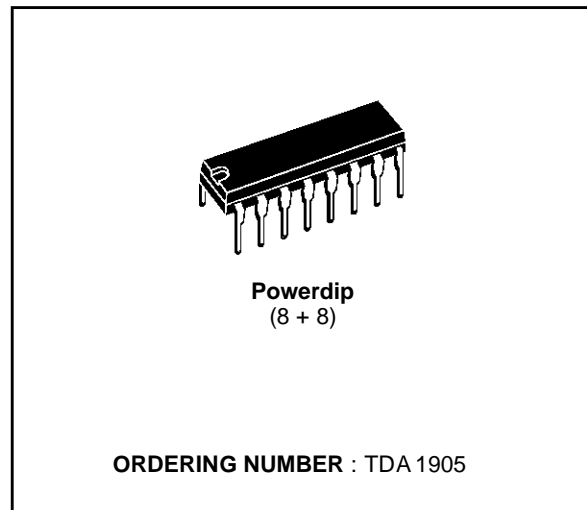

ABSOLUTE MAXIMUM RATINGS

Symbol	Parameter	Value	Unit
V_s	Supply voltage	30	V
I_o	Output peak current (non repetitive)	3	A
I_o	Output peak current (repetitive)	2.5	A
V_i	Input voltage	0 to + V_s	V
V_i	Differential input voltage	± 7	V
V_{11}	Muting threshold voltage	V_s	V
P_{tot}	Power dissipation at $T_{amb} = 80^\circ\text{C}$	1	W
	$T_{case} = 60^\circ\text{C}$	6	W
T_{stg}, T_j	Storage and junction temperature	-40 to 150	$^\circ\text{C}$

APPLICATION CIRCUIT

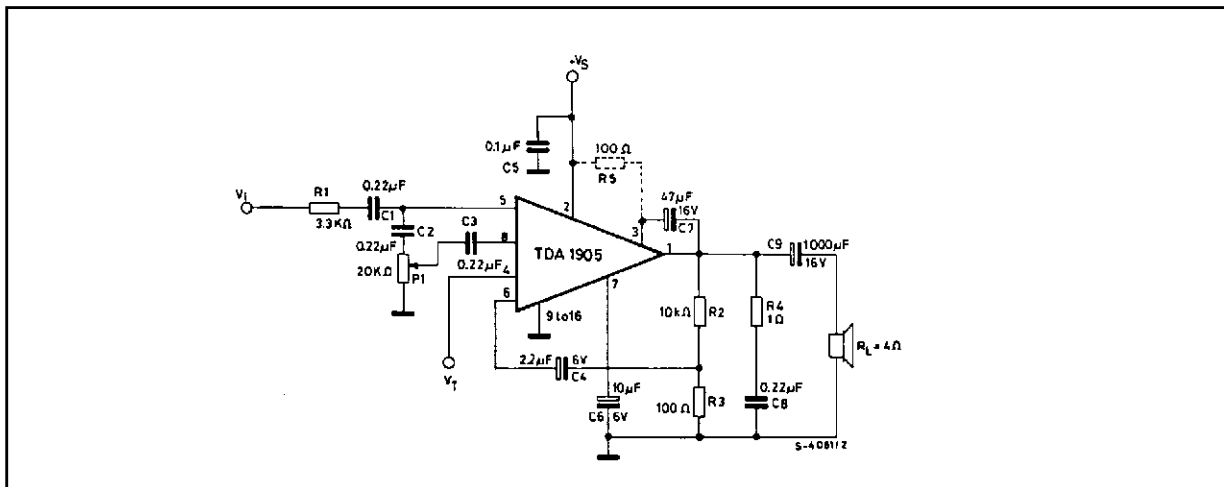

TDA1905

PIN CONNECTION (top view)

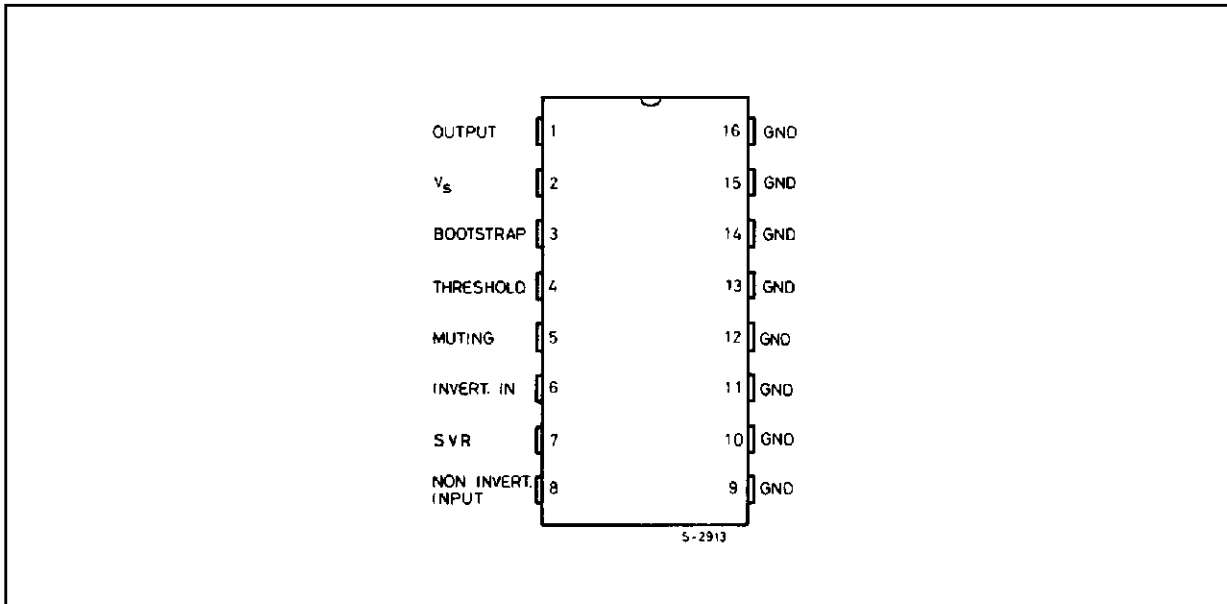

SCHEMATIC DIAGRAM

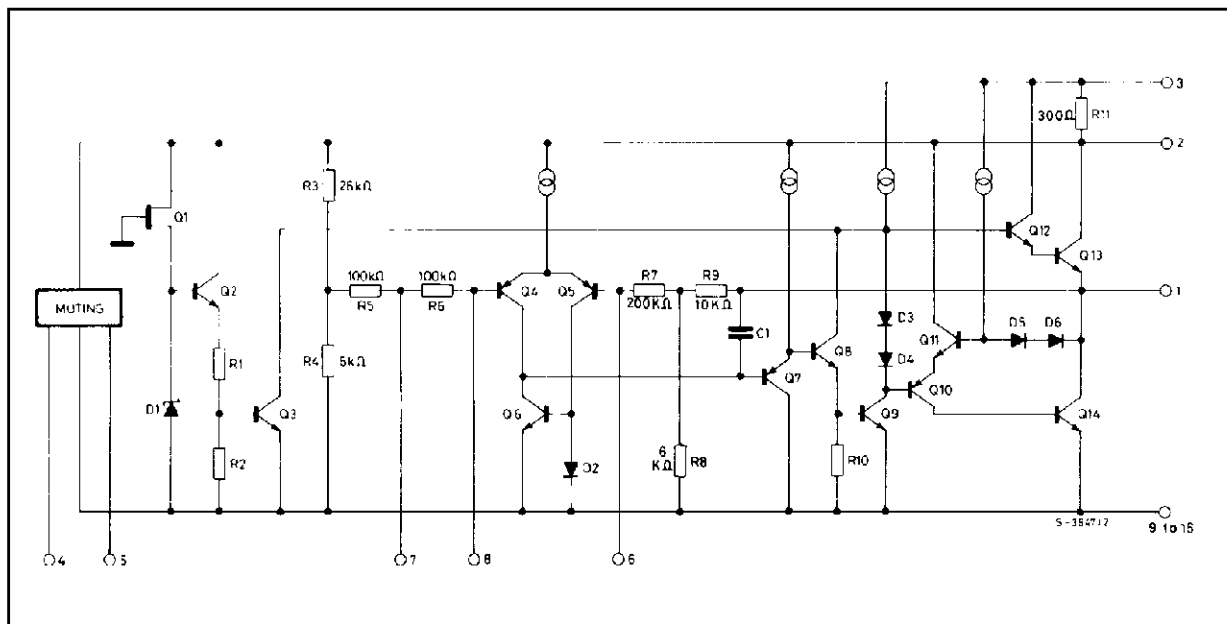

THERMAL DATA

Symbol	Parameter	Value	Unit
R _{th-j-case}	Thermal resistance junction-pins	max 15	°C/W
R _{th-j-amb}	Thermal resistance junction-ambient	max 70	°C/W

TEST CIRCUITS:
WITHOUT MUTING

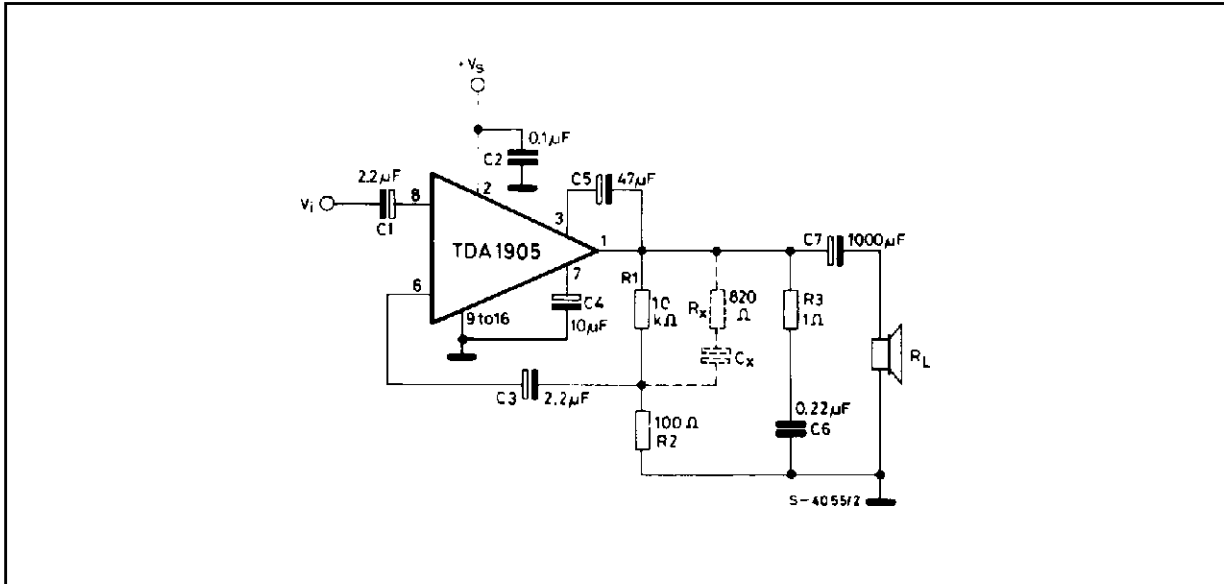

WITH MUTING FUNCTION

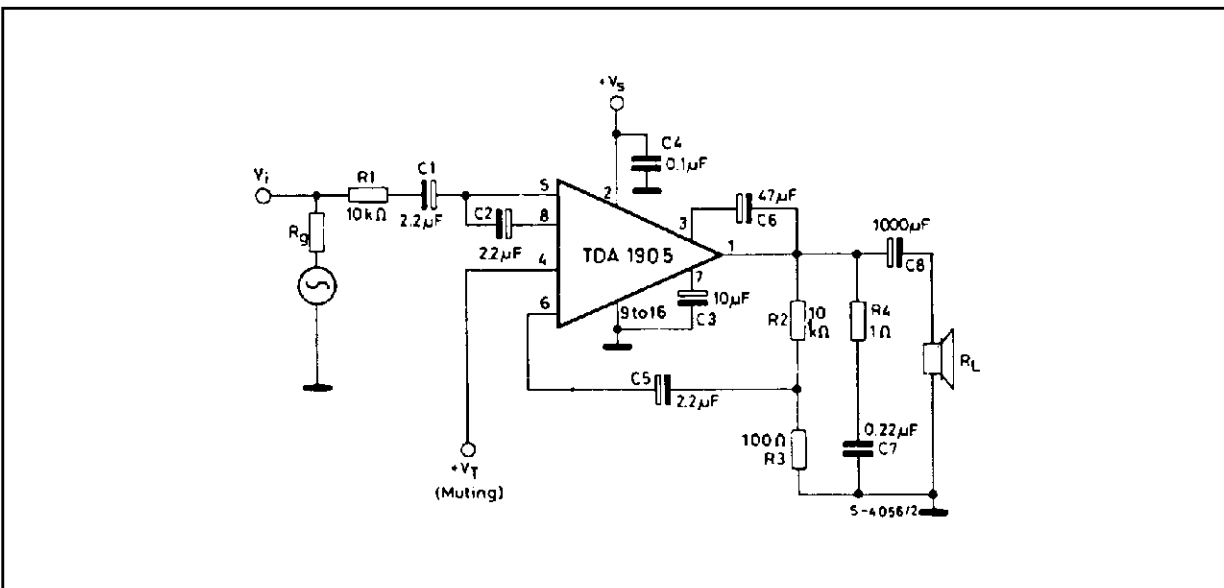

ELECTRICAL CHARACTERISTICS (Refer to the test circuit, $T_{amb} = 25\text{ }^{\circ}\text{C}$, R_{th} (heatsink) = $20\text{ }^{\circ}\text{C/W}$, unless otherwise specified)

Symbol	Parameter	Test conditions	Min.	Typ.	Max.	Unit
V_s	Supply voltage		4		30	V
V_o	Quiescent output voltage	$V_s = 4\text{V}$ $V_s = 14\text{V}$ $V_s = 30\text{V}$	1.6 6.7 14.4	2.1 7.2 15.5	2.5 7.8 16.8	V
I_d	Quiescent drain current	$V_s = 4\text{V}$ $V_s = 14\text{V}$ $V_s = 30\text{V}$		15 17 21	35	mA
$V_{CE\text{ sat}}$	Output stage saturation voltage	$I_C = 1\text{A}$ $I_C = 2\text{A}$		0.5 1		V
P_o	Output power	$d = 10\%$ $f = 1\text{KHz}$ $V_s = 9\text{V}$ $R_L = 4\Omega$ (*) $V_s = 14\text{V}$ $R_L = 4\Omega$ $V_s = 18\text{V}$ $R_L = 8\Omega$ $V_s = 24\text{V}$ $R_L = 16\Omega$	2.2 5 5 4.5	2.5 5.5 5.5 5.3		W
d	Harmonic distortion	$f = 1\text{KHz}$ $V_s = 9\text{V}$ $R_L = 4\Omega$ $P_o = 50\text{ mW to } 1.5\text{W}$ $V_s = 14\text{V}$ $R_L = 4\Omega$ $P_o = 50\text{ mW to } 3\text{W}$ $V_s = 18\text{V}$ $R_L = 8\Omega$ $P_o = 50\text{ mW to } 3\text{W}$ $V_s = 24\text{V}$ $R_L = 16\Omega$ $P_o = 50\text{ mW to } 3\text{W}$		0.1 0.1 0.1 0.1		%
V_i	Input sensitivity	$f = 1\text{KHz}$ $V_s = 9\text{V}$ $R_L = 4\Omega$ $P_o = 2.5\text{W}$ $V_s = 14\text{V}$ $R_L = 4\Omega$ $P_o = 5.5\text{W}$ $V_s = 18\text{V}$ $R_L = 8\Omega$ $P_o = 5.5\text{W}$ $V_s = 24\text{V}$ $R_L = 16\Omega$ $P_o = 5.3\text{W}$		37 49 73 100		mV
V_i	Input saturation voltage (rms)	$V_s = 9\text{V}$ $V_s = 14\text{V}$ $V_s = 18\text{V}$ $V_s = 24\text{V}$	0.8 1.3 1.8 2.4			V
R_i	Input resistance (pin 8)	$f = 1\text{KHz}$	60	100		$\text{K}\Omega$
I_d	Drain current	$f = 1\text{KHz}$ $V_s = 9\text{V}$ $R_L = 4\Omega$ $P_o = 2.5\text{W}$ $V_s = 14\text{V}$ $R_L = 4\Omega$ $P_o = 5.5\text{W}$ $V_s = 18\text{V}$ $R_L = 8\Omega$ $P_o = 5.5\text{W}$ $V_s = 24\text{V}$ $R_L = 16\Omega$ $P_o = 5.3\text{W}$		380 550 410 295		mA
η	Efficiency	$f = 1\text{KHz}$ $V_s = 9\text{V}$ $R_L = 4\Omega$ $P_o = 2.5\text{W}$ $V_s = 14\text{V}$ $R_L = 4\Omega$ $P_o = 5.5\text{W}$ $V_s = 18\text{V}$ $R_L = 8\Omega$ $P_o = 5.5\text{W}$ $V_s = 24\text{V}$ $R_L = 16\Omega$ $P_o = 5.3\text{W}$		73 71 74 75		%

(*) With an external resistor of 100Ω between pin 3 and $+V_s$.

ELECTRICAL CHARACTERISTICS (continued)

Symbol	Parameter	Test conditions	Min.	Typ.	Max.	Unit
BW	Small signal bandwidth (-3dB)	$V_s = 14V$ $R_L = 4\Omega$ $P_o = 1W$	40 to 40,000			Hz
G_v	Voltage gain (open loop)	$V_s = 14V$ $f = 1KHz$		75		dB
G_v	Voltage gain (closed loop)	$V_s = 14V$ $R_L = 4\Omega$ $f = 1KHz$ $P_o = 1W$	39.5	40	40.5	dB
e_N	Total input noise	$R_g = 50\Omega$ $R_g = 1K\Omega$ $(^\circ)$ $R_g = 10K\Omega$		1.2 1.3 1.5	4.0	μV
		$R_g = 50\Omega$ $R_g = 1K\Omega$ $(^{\circ\circ})$ $R_g = 10K\Omega$		2.0 2.0 2.2	6.0	μV
S/N	Signal to noise ratio	$V_s = 14V$ $P_o = 5.5W$ $R_L = 4\Omega$	$R_g = 10K\Omega$ $R_g = 0$ $(^\circ)$	90 92		dB
			$R_g = 10K\Omega$ $R_g = 0$ $(^{\circ\circ})$	87 87		dB
SVR	Supply voltage rejection	$V_s = 18V$ $R_L = 8\Omega$ $f_{ripple} = 100$ Hz $R_g = 10K\Omega$ $V_{ripple} = 0.5V_{rms}$	40	50		dB
T_{sd}	Thermal shut-down case temperatura (*)	$P_{tot} = 2.5W$		115		$^\circ C$

MUTING FUNCTION

$V_{T_{OFF}}$	Muting-off threshold voltage (pin 4)		1.9		4.7	V
$V_{T_{ON}}$	Muting-on threshold voltage (pin 4)		0		1.3	V
			6.2		V_s	
R_5	Input-resistance (pin 5)	Muting off	80	200		$K\Omega$
		Muting on		10	30	Ω
R_4	Input resistance (pin 4)		150			$K\Omega$
A_T	Muting attenuation	$R_g + R_1 = 10K\Omega$	50	60		dB

Note:

- ($^\circ$) Weighting filter = curve A.
($^{\circ\circ}$) Filter with noise bandwidth: 22 Hz to 22 KHz.
(*) See fig. 30 and fig. 31

Figure 1. Quiescent output voltage vs. supply voltage

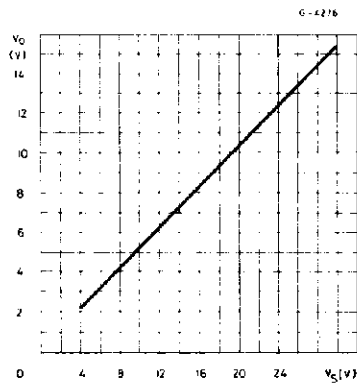

Figure 2. Quiescent drain current vs. supply voltage

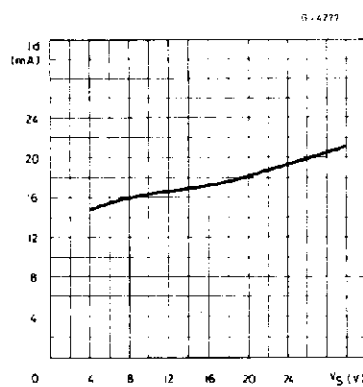

Figure 3. Output power vs. supply voltage

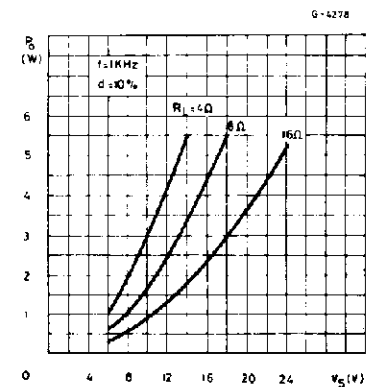

Figure 4. Distortion vs. output power ($R_L = 16\Omega$)

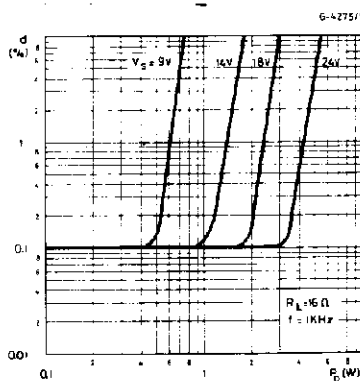

Figure 5. Distortion vs. output power ($R_L = 8\Omega$)

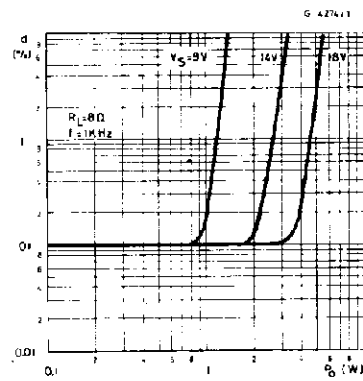

Figure 6. Distortion vs. output power ($R_L = 4\Omega$)

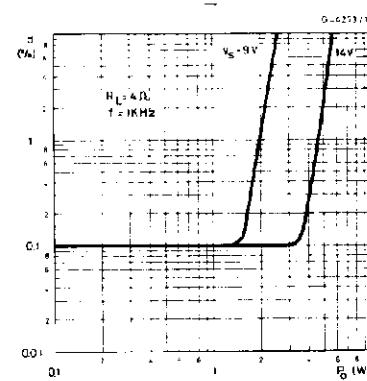

Figure 7. Distortion vs. frequency ($R_L = 16\Omega$)

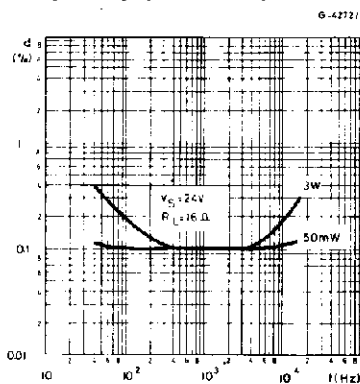

Figure 8. Distortion vs. frequency ($R_L = 8\Omega$)

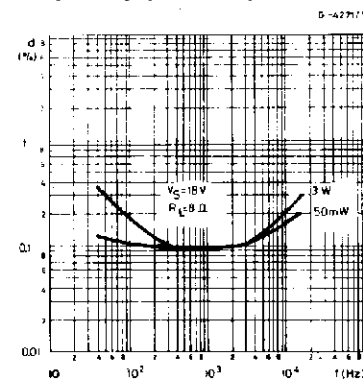

Figure 9. Distortion vs. frequency ($R_L = 4\Omega$)

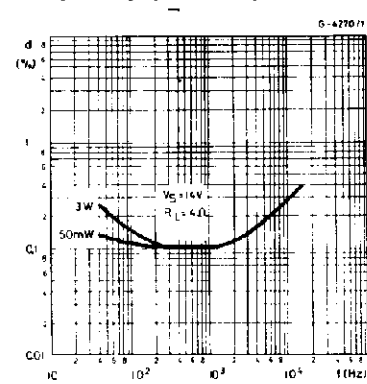

Figure 10. Open loop frequency response

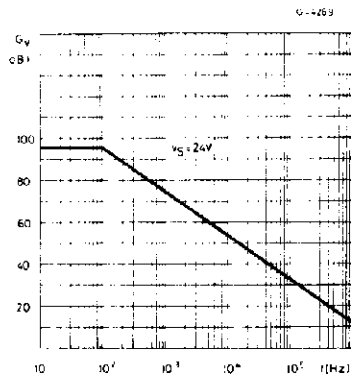

Figure 11. Output power vs. input voltage

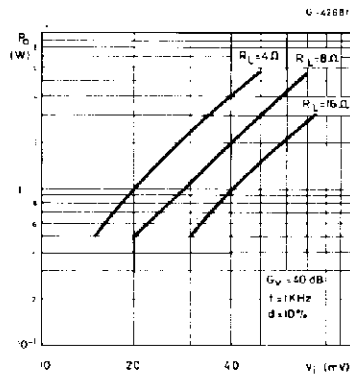

Figure 12. Value of capacitor Cx vs. bandwidth (BW) and gain (Gv)

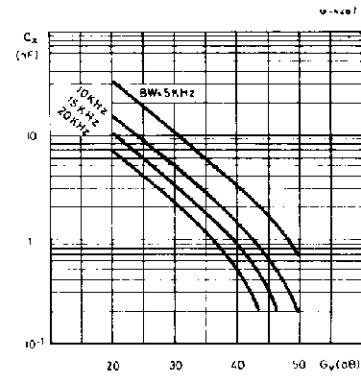

Figure 13. Supply voltage rejection vs. voltage gain (ref. to the Muting circuit)

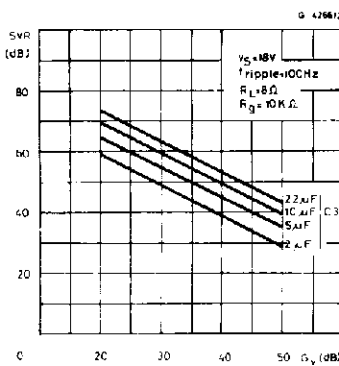

Figure 14. Supply voltage rejection vs. source resistance

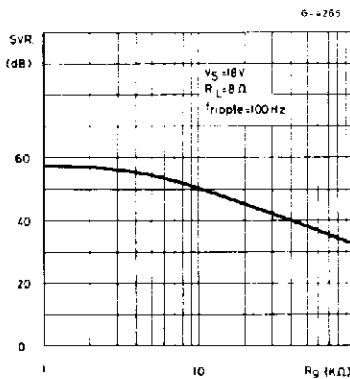

Figure 15. Max power dissipation vs. supply voltage (sine wave operation)

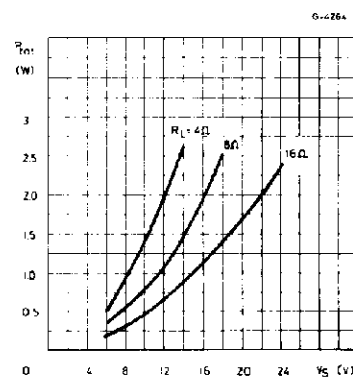

Figure 16. Power dissipation and efficiency vs. output power

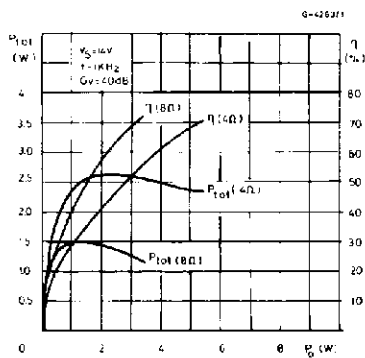

Figure 17. Power dissipation and efficiency vs. output power

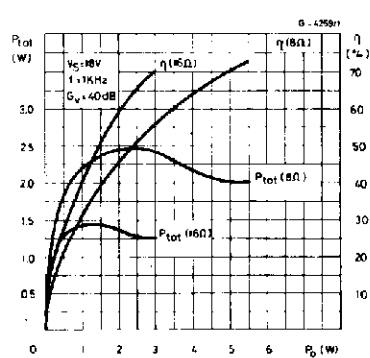
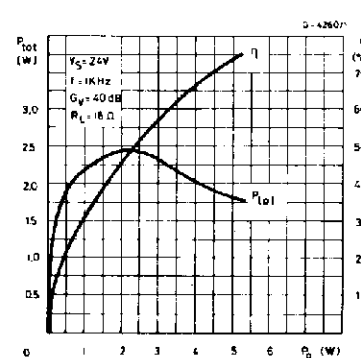

Figure 18. Power dissipation and efficiency vs. output power



APPLICATION INFORMATION

Figure 19. Application circuit without muting

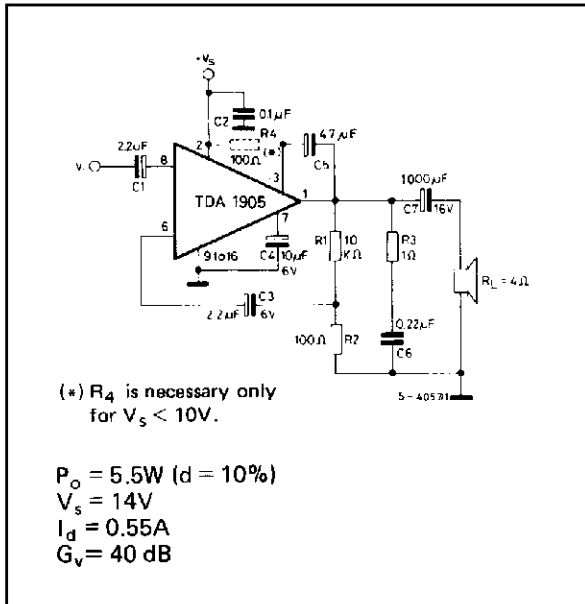

Figure 20. PC board and components lay-out of the circuit of fig. 19 (1 : 1 scale)

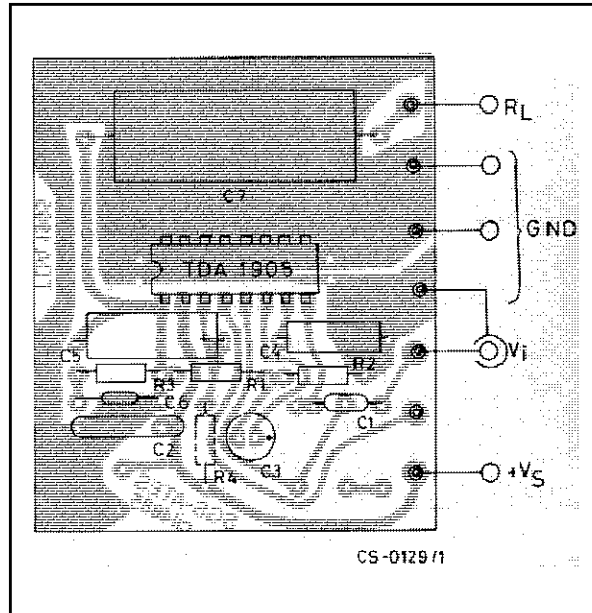

Figure 21. Application circuit with muting

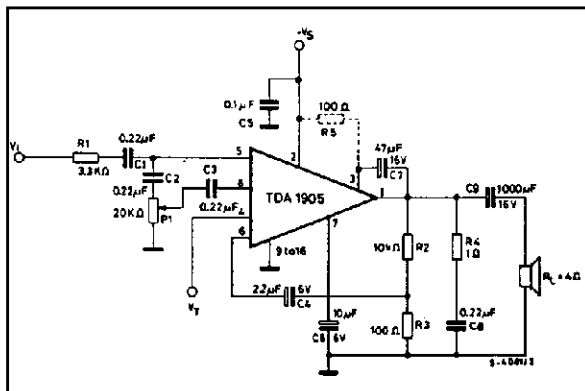
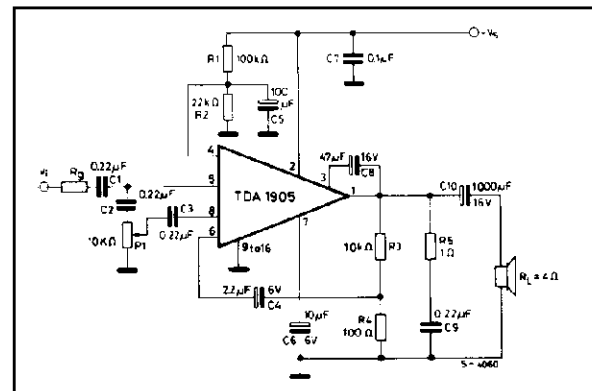

Figure 22. Delayed muting circuit



APPLICATION INFORMATION (continued)

Figure 23. Low-cost application circuit without bootstrap.

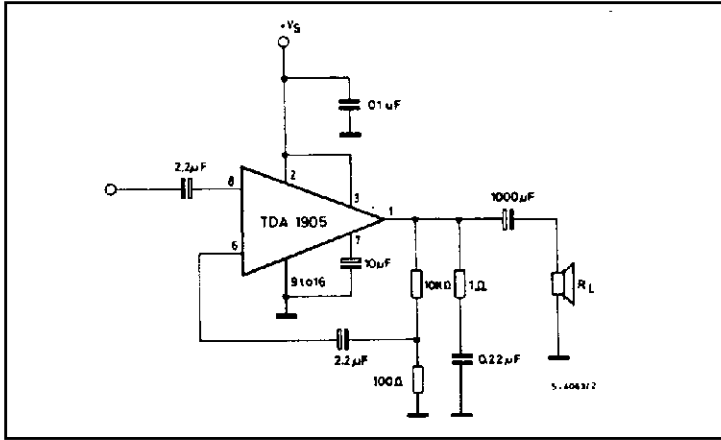

Figure 24. Output power vs. supply voltage (circuit of fig. 23)

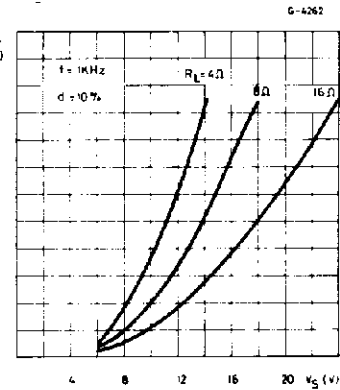

Figure 25. Two position DC tone control using change of pin 5 resistance (muting function)

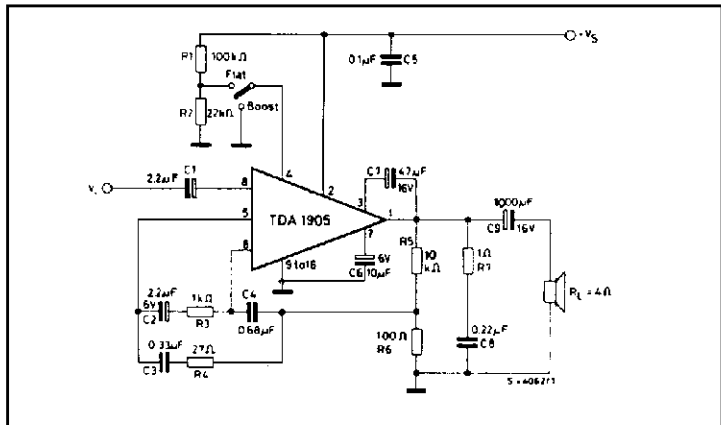

Figure 26. Frequency response of the circuit of fig. 25

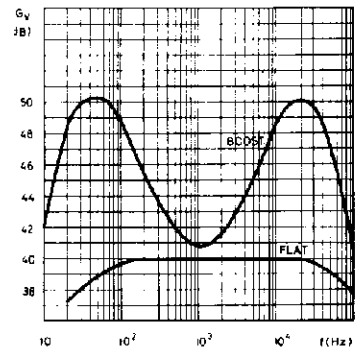

Figure 27. Bass Bomb tone control using change of pin 5 resistance (muting function)

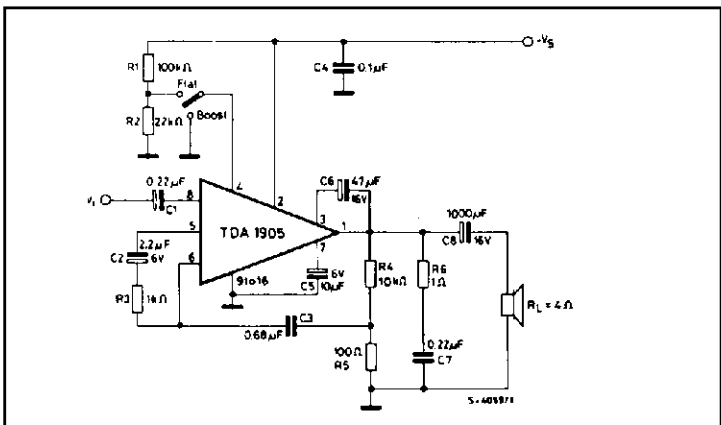
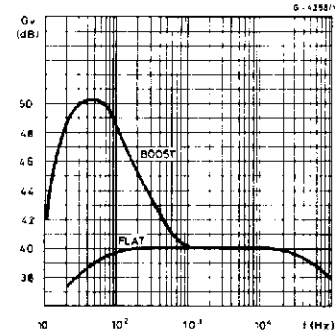

Figure 28. Frequency response of the circuit of fig. 27



MUTING FUNCTION

The output signal can be inhibited applying a DC voltage V_T to pin 4, as shown in fig. 29

Figure 29

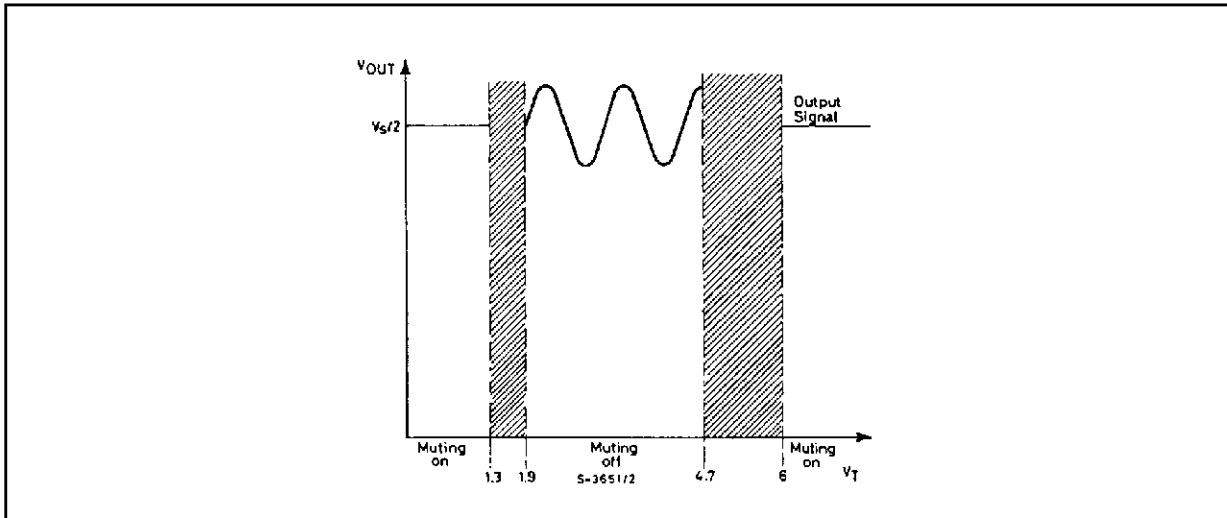

The input resistance at pin 5 depends on the threshold voltage V_T at pin 4 and is typically :

$R_5 = 200\text{ K}\Omega$	@	$1.9\text{V} \leq V_T \leq 4.7\text{V}$	muting-off
$R_5 = 10\ \Omega$	@	$0\text{V} \leq V_T \leq 1.3\text{V}$ $6\text{V} \leq V_T \leq V_s$	muting-on

Referring to the following input stage, the possible attenuation of the input signal and therefore of the output signal can be found using the following expression:

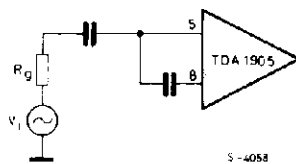

$$A_T = \frac{V_i}{V_8} = \frac{R_g + \left(\frac{R_8 \cdot R_5}{R_8 + 5} \right)}{\left(\frac{R_8 \cdot R_5}{R_8 + R_5} \right)}$$

where $R_8 \cong 100\text{ K}\Omega$

Considering $R_g = 10\text{ K}\Omega$ the attenuation in the muting-on condition is typically $A_T = 60\text{ dB}$. In the muting-off condition, the attenuation is very low, typically 1.2 dB.

A very low current is necessary to drive the threshold voltage V_T because the input resistance at pin 4 is greater than 150 K Ω . The muting function can be used in many cases, when a temporary inhibition of the output signal is requested, for example:

- in switch-on condition, to avoid preamplifier power-on transients (see fig. 22)

- during switching at the input stages.
- during the receiver tuning.

The variable impedance capability at pin 5 can be useful in many applications and two examples are shown in fig. 25 and 27, where it has been used to change the feedback network, obtaining 2 different frequency responses.

APPLICATION SUGGESTION

The recommended values of the external components are those shown on the application circuit of fig. 21. When the supply voltage V_s is less than 10V, a 100 Ω resistor must be connected between pin 2 and pin 3 in order to obtain the maximum output power.

Different values can be used. The following table can help the designer.

Component	Raccom. value	Purpose	Larger than recommended value	Smaller than recommended value	Allowed range	
					Min.	Max.
$R_g + R_1$	10K Ω	Input signal impeded for muting operation	Increase of the attenuation in muting-on condition. Decrease of the input sensitivity.	Decrease of the attenuation in muting on condition.		
R_2	10K Ω	Feedback resistors	Increase of gain.	Decrease of gain. Increase quiescent current.	9 R_3	
R_3	100 Ω		Decrease of gain.	Increase of gain.		1K Ω
R_4	1K Ω	Frequency stability	Danger of oscillation at high frequencies with inductive loads.			
R_5	100 Ω	Increase of the output swing with low supply voltage.			47	330
P_1	20K Ω	Volume potentiometer	Increase of the switch-on noise.	Decrease of the input impedance and of the input level.	10K Ω	100K Ω
C_1 C_2 C_3	0.22 μ F	Input DC decoupling.	Higher cost lower noise.	Higher low frequency cutoff. Higher noise.		
C_4	2.2 μ F	Inverting input DC decoupling.	Increase of the switch-on noise.	Higher low frequency cutoff.	0.1 μ F	
C_5	0.1 μ F	Supply voltage bypass.		Danger of oscillations.		
C_6	10 μ F	Ripple rejection	Increase of SVR increase of the switch-on time	Degradation of SVR	2.2 μ F	100 μ F
C_7	47 μ F	Bootstrap.		Increase of the distortion at low frequency.	10 μ F	100 μ F
C_8	0.22 μ F	Frequency stability.		Danger of oscillation.		
C_9	1000 μ F	Output DC decoupling.		Higher low frequency cutoff.		

THERMAL SHUT-DOWN

The presence of a thermal limiting circuit offers the following advantages:

- 1) An overload on the output (even if it is permanent), or an above limit ambient temperature can be easily tolerated since the T_j cannot be higher than $150\text{ }^\circ\text{C}$.
- 2) The heatsink can have a smaller factor of safety compared with that of a conventional circuit. There is no possibility of device damage due to high junction temperature.
If for any reason, the junction temperature increases up to $150\text{ }^\circ\text{C}$, the thermal shut-down simply reduces the power dissipation and the current consumption.

The maximum allowable power dissipation depends upon the size of the external heatsink (i.e. its thermal resistance); fig. 32 shows this dissipable power as a function of ambient temperature for different thermal resistance.

Figure 30. Output power and drain current vs. case temperature

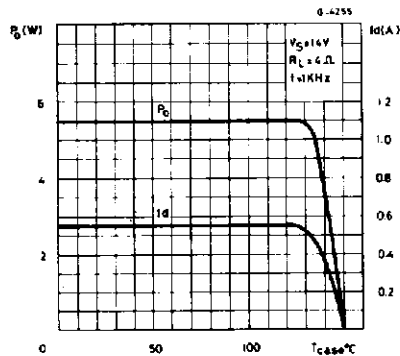

Figure 31. Output power and drain current vs. case temperature

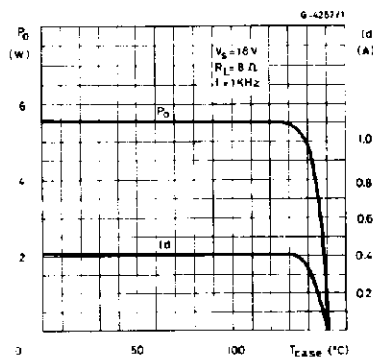
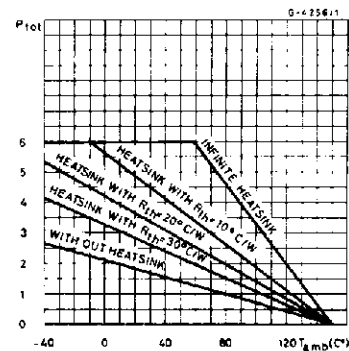

Figure 32. Maximum allowable power dissipation vs. ambient temperature



MOUNTING INSTRUCTION : See TDA1904

POWERDIP PACKAGE MECHANICAL DATA

DIM.	mm			inch		
	MIN.	TYP.	MAX.	MIN.	TYP.	MAX.
a1	0.51			0.020		
B	0.85		1.40	0.033		0.055
b		0.50			0.020	
b1	0.38		0.50	0.015		0.020
D			20.0			0.787
E		8.80			0.346	
e		2.54			0.100	
e3		17.78			0.700	
F			7.10			0.280
I			5.10			0.201
L		3.30			0.130	
Z			1.27			0.050

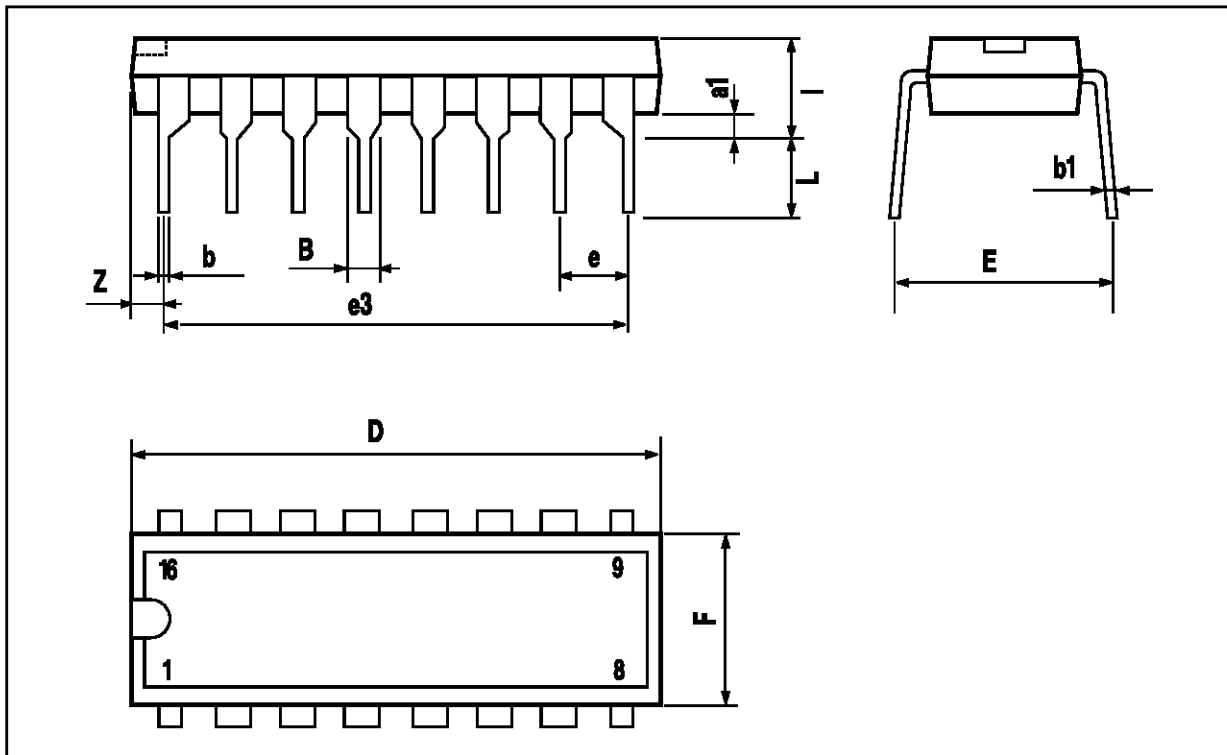

Information furnished is believed to be accurate and reliable. However, SGS-THOMSON Microelectronics assumes no responsibility for the consequences of use of such information nor for any infringement of patents or other rights of third parties which may result from its use. No license is granted by implication or otherwise under any patent or patent rights of SGS-THOMSON Microelectronics. Specifications mentioned in this publication are subject to change without notice. This publication supersedes and replaces all information previously supplied. SGS-THOMSON Microelectronics products are not authorized for use as critical components in life support devices or systems without express written approval of SGS-THOMSON Microelectronics.

© 1994 SGS-THOMSON Microelectronics - All Rights Reserved

SGS-THOMSON Microelectronics GROUP OF COMPANIES

Australia - Brazil - France - Germany - Hong Kong - Italy - Japan - Korea - Malaysia - Malta - Morocco - The Netherlands - Singapore - Spain - Sweden - Switzerland - Taiwan - Thailand - United Kingdom - U.S.A.