

4-Pin Microcontroller Reset Monitors

Features

- Precision V_{DD} Monitor for 2.0V, 2.8V, 3.0V, 3.3V, 5.0V Nominal Supplies
- Manual Reset Input
- 140 msec Minimum RESET Output Duration
- RESET Output Valid to $V_{DD} = 1.0V$ (TCM811)
- Low 6 μA (typ.) Supply Current
- V_{DD} Transient Immunity
- Small 4-Pin SOT-143 Package
- No External Components
- Replacement for MAX811/812 and Offers a Lower Threshold Voltage Option
- Push-Pull RESET Output
- Temperature Range:
 - Commercial (C) $-40^{\circ}C$ to $+85^{\circ}C$

Applications

- Computers
- Embedded Systems
- Battery Powered Equipment
- Critical Microcontroller Power Supply Monitoring

Typical Application Circuit

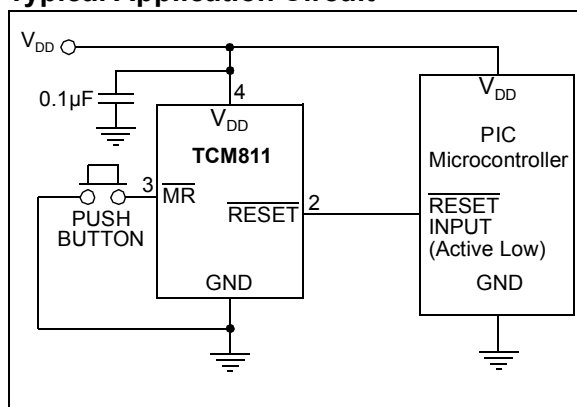

General Description

The TCM811 and TCM812 are cost effective system supervisory circuits designed to monitor V_{DD} in digital systems and provide a reset signal to the host controller when necessary. A manual reset input is provided to override the reset monitor and is suitable for use as a push-button reset. No external components are required.

The reset output is driven active within 20 μsec (5 μsec for F version) of V_{DD} falling through the reset voltage threshold. RESET is maintained active for a minimum of 140 msec after V_{DD} rises above the reset threshold. The TCM812 has an active high RESET output while the TCM811 has an active low RESET output. The output of the TCM811 is valid down to $V_{DD} = 1V$. Both devices are available in a 4-Pin SOT-143 package, specified with a temperature range of $-40^{\circ}C$ to $+85^{\circ}C$.

The TCM811/TCM812 are optimized to reject fast transient glitches on the V_{DD} line. A low supply current of 6 μA ($V_{DD} = 3.3V$) makes these devices ideal for battery powered applications.

Package Types:

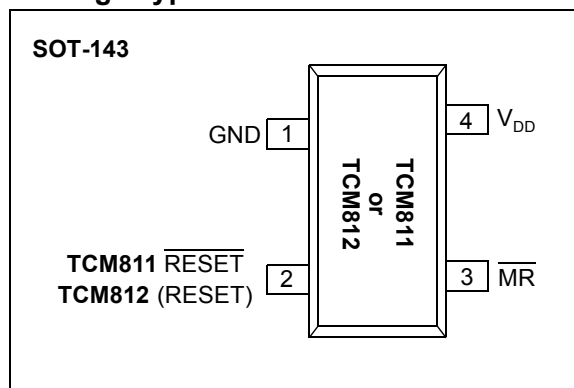

TCM811/TCM812

1.0 ELECTRICAL CHARACTERISTICS

ABSOLUTE MAXIMUM RATINGS*

Supply Voltage (V_{DD} to GND).....	+6.0V
$\overline{\text{RESET}}$, RESET.....	- 0.3V to (V_{DD} + 0.3V)
Input Current, V_{DD}20 mA
Output Current, $\overline{\text{RESET}}$, RESET.....	.20 mA
Operating Temperature Range.....	- 40°C to +85°C
Storage Temperature Range.....	- 65°C to +150°C
Maximum Junction Temperature, T_J	150°C

***Notice:** Stresses beyond those listed under "Absolute Maximum Ratings" may cause permanent damage to the device. These are stress ratings only, and functional operation of the device at these or any other conditions beyond those indicated in the operational sections of the specifications is not implied. Exposure to absolute maximum rating conditions for extended periods may affect device reliability.

PIN FUNCTION TABLE

NAME	FUNCTION
GND	Ground
RESET (TCM811)	RESET push-pull output remains low while V_{DD} is below the reset voltage threshold, and for at least 140 msec (min.) after V_{DD} rises above reset threshold.
RESET (TCM812)	RESET push-pull output remains high while V_{DD} is below the reset voltage threshold, and for at least 140 msec (min.) after V_{DD} rises above reset threshold.
$\overline{\text{MR}}$	Manual Reset input generates a reset when $\overline{\text{MR}}$ is below V_{IL} .
V_{DD}	Supply Voltage

ELECTRICAL CHARACTERISTICS

V_{DD} = 5V for L/M versions, V_{DD} = 3.3V for T/S versions, V_{DD} = 3V for R version, V_{DD} = 2.0V for F version. T_A = -40°C to +85°C, unless otherwise noted. Typical values are at T_A = +25°C. (Note 1)						
Parameters	Sym	Min	Typ	Max	Units	Conditions
V_{DD} Range	V_{DD}	1.0 1.1	— —	5.5 5.5	V	TCM811 TCM812
Supply Current	I_{CC}	— —	6 4.75	15 10	μA	TCM81_L/M, V_{DD} = 5.5V, I_{OUT} = 0 TCM81_R/S/T/F, V_{DD} = 3.6V, I_{OUT} = 0
Reset Threshold	V_{TH}	4.54 4.50	4.63 —	4.72 4.75	V	TCM81_L: T_A = +25°C T_A = -40°C to +85°C
		4.30 4.25	4.38 —	4.46 4.50		TCM81_M: T_A = +25°C T_A = -40°C to +85°C
		3.03 3.00	3.08 —	3.14 3.15		TCM81_T: T_A = +25°C T_A = -40°C to +85°C
		2.88 2.85	2.93 —	2.98 3.00		TCM81_S: T_A = +25°C T_A = -40°C to +85°C
		2.58 2.55	2.63 —	2.68 2.70		TCM81_R: T_A = +25°C T_A = -40°C to +85°C
		1.71 1.70	1.75 —	1.79 1.80		TCM81_F: T_A = +25°C T_A = -40°C to +85°C
Reset Threshold Tempco		—	30	—	ppm/°C	
V_{DD} to Reset Delay		— —	20 5	— —	μsec	V_{DD} = V_{TH} to V_{TH} -125 mV; L, M, R, S, T, F
Reset Active Timeout Period	t_{RP}	140	280	560	msec	V_{DD} = $V_{TH(MAX)}$
$\overline{\text{MR}}$ Minimum Pulse Width	t_{MR}	10	—	—	μsec	
$\overline{\text{MR}}$ Glitch Immunity		—	100	—	nsec	
$\overline{\text{MR}}$ to Reset Propagation Delay	t_{MD}	—	0.5	—	μsec	

Note 1: Production testing done at T_A = +25°C and +85°C, over temperature limits are tested with periodic QA tests in production.

TCM811/TCM812

$V_{DD} = 5V$ for L/M versions, $V_{DD} = 3.3V$ for T/S versions, $V_{DD} = 3V$ for R version, $V_{DD} = 2.0V$ for F version.
 $T_A = -40^{\circ}C$ to $+85^{\circ}C$, unless otherwise noted. Typical values are at $T_A = +25^{\circ}C$. (Note 1)

Parameters	Sym	Min	Typ	Max	Units	Conditions
MR Input Threshold	V_{IH} V_{IL}	2.3 —	— —	— 0.8	V	$V_{DD} > V_{TH(MAX)}$, TCM81_L/M
	V_{IH} V_{IL}	$0.7 V_{DD}$ —	— —	— $0.25 V_{DD}$	V	$V_{DD} > V_{TH(MAX)}$, TCM81_R/S/T/F
MR Pull-up Resistance		10	20	40	k Ω	
RESET Output Voltage Low (TCM811)	V_{OL}	—	—	0.3	V	TCM811R/S/T only; $I_{SINK} = 1.2 \text{ mA}$, $V_{DD} = V_{TH(MIN)}$
		—	—	0.4	V	TCM811F only; $I_{SINK} = 500 \mu\text{A}$, $V_{DD} = V_{TH(MIN)}$
		—	—	0.3	V	TCM811L/M only; $I_{SINK} = 3.2 \text{ mA}$, $V_{DD} = V_{TH(MIN)}$ $I_{SINK} = 3.2 \text{ mA}$, $V_{DD} = V_{TH(MIN)}$
RESET Output Voltage High (TCM811)	V_{OH}	$0.8 V_{DD}$	—	—	V	TCM811R/S/T/F only; $I_{SOURCE} = 500 \mu\text{A}$, $V_{DD} > V_{TH(MAX)}$
		$V_{DD} - 1.5$	—	—	V	TCM811L/M only; $I_{SOURCE} = 800 \mu\text{A}$, $V_{DD} > V_{TH(MAX)}$
RESET Output Voltage Low (TCM812)	V_{OL}	—	—	0.2	V	TCM812F only, $I_{SINK} = 500 \mu\text{A}$, $V_{DD} = V_{TH(MAX)}$
		—	—	0.3		TCM812R/S/T only, $I_{SINK} = 1.2 \text{ mA}$, $V_{DD} = V_{TH(MAX)}$
		—	—	0.4		TCM812L/M only, $I_{SINK} = 1.2 \text{ mA}$, $V_{DD} = V_{TH(MAX)}$
RESET Output Voltage High (TCM812)	V_{OH}	$0.8 V_{DD}$	—	—	V	$I_{SOURCE} = 150 \mu\text{A}$, $V_{DD} \leq V_{TH(MIN)}$

Note 1: Production testing done at $T_A = +25^{\circ}C$ and $+85^{\circ}C$, over temperature limits are tested with periodic QA tests in production.

TCM811/TCM812

2.0 APPLICATIONS INFORMATION

The TCM811/TCM812 provides accurate V_{DD} monitoring and reset timing during power-up, power-down, and brownout/sag conditions. These devices also reject negative-going transients (glitches) on the power supply line. Figure 2-1 shows the maximum transient duration vs. maximum negative excursion (overdrive) for glitch rejection. Any combination of duration and overdrive that is under the curve will not generate a reset signal. Combinations above the curve are detected as a brownout or power-down. Transient immunity can be improved by adding a 0.1 μF capacitor in close proximity to the V_{DD} pin of the TCM811/812.

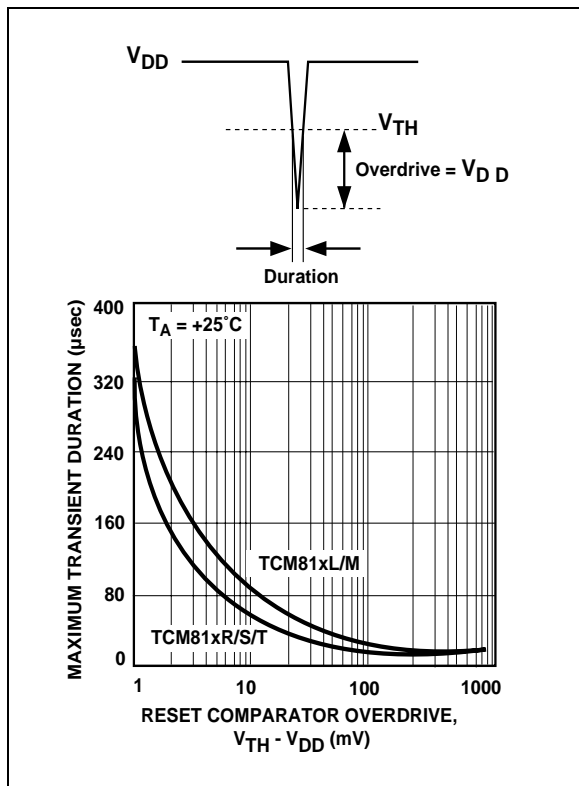

FIGURE 2-1: Maximum Transient Duration vs. Overdrive for Glitch Rejection at 25°C.

2.1 RESET Signal Integrity During Power-Down

The TCM811 RESET push-pull output is valid to $V_{DD} = 1.0\text{V}$. Below this voltage the output becomes an "open circuit" and does not sink current. This means CMOS logic inputs to the microcontroller will be floating at an undetermined voltage. Most digital systems are completely shutdown well above this voltage. However, in situations where RESET must be maintained valid to $V_{DD} = 0\text{V}$, a pull-down resistor must be connected from RESET to ground to discharge stray capacitances and hold the output low (Figure 2-2). This resistor value, though not critical, should be chosen such that it does not appreciably load RESET under normal operation

(100 k Ω will be suitable for most applications). Similarly, a pull-up resistor to V_{DD} is required for the TCM812 to ensure a valid high RESET for V_{DD} below 1.1V.

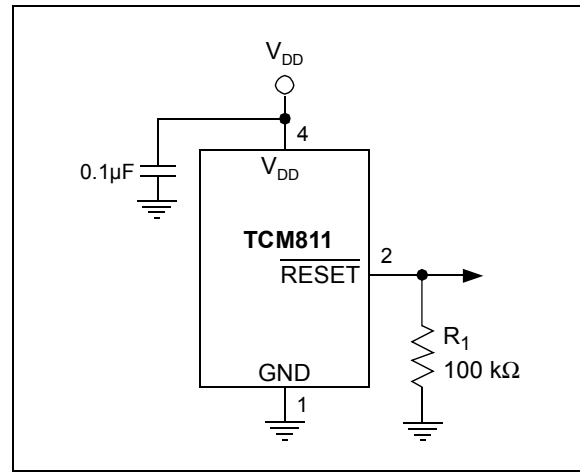

FIGURE 2-2: The addition of R_1 at the RESET output of the TCM811 ensures that the RESET output is valid to $V_{DD} = 0\text{V}$.

2.2 Controllers and Processors With Bidirectional I/O Pins

Some microcontrollers have bi-directional reset pins. Depending on the current drive capability of the controller pin, an indeterminate logic level may result if there is a logic conflict. This can be avoided by adding a 4.7 k Ω resistor in series with the output of the TCM811/TCM812 (Figure 2-3). If there are other components in the system which require a reset signal, they should be buffered so as not to load the reset line. If the other components are required to follow the reset I/O of the microcontroller, the buffer should be connected as shown with the solid line.

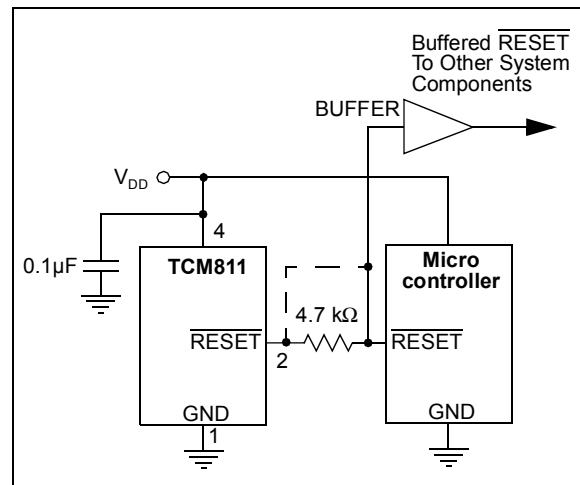

FIGURE 2-3: Interfacing the TCM811 to a Bi-directional Reset I/O.

3.0 TYPICAL PERFORMANCE CHARACTERISTICS

Note: The graphs provided following this note are a statistical summary based on a limited number of samples and are provided for informational purposes only. The performance characteristics listed herein are not tested or guaranteed. In some graphs, the data presented may be outside the specified operating range (e.g., outside specified power supply range) and therefore outside the warranted range.

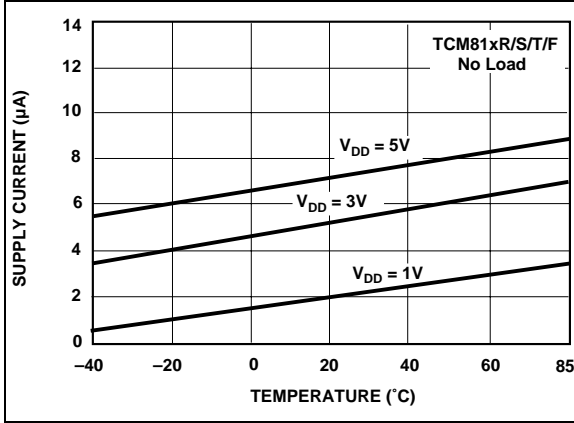

FIGURE 3-1: Supply Current vs. Temperature.

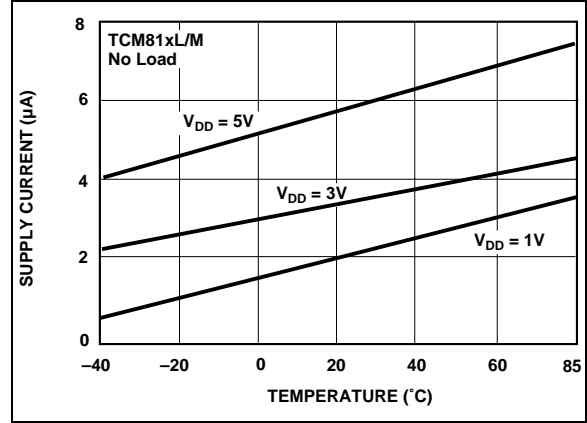

FIGURE 3-4: Supply Current vs. Temperature.

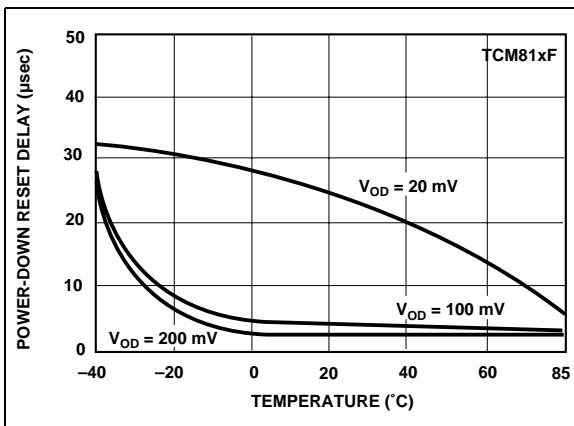

FIGURE 3-2: Power-Down Reset Delay vs. Temperature.

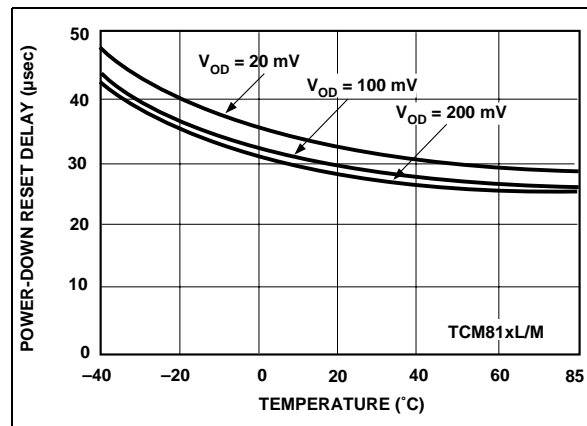

FIGURE 3-5: Power-Down Reset Delay vs. Temperature.

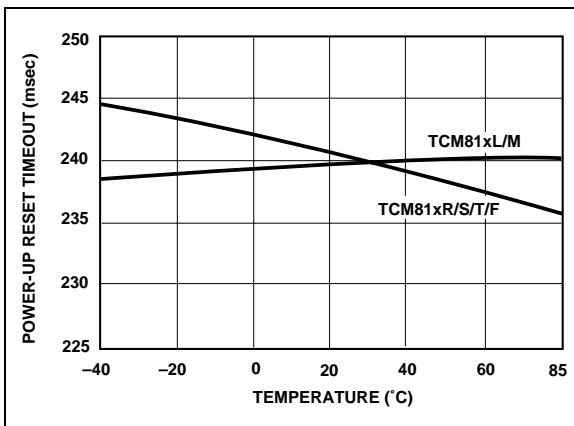

FIGURE 3-3: Power-Up Reset Timeout vs. Temperature.

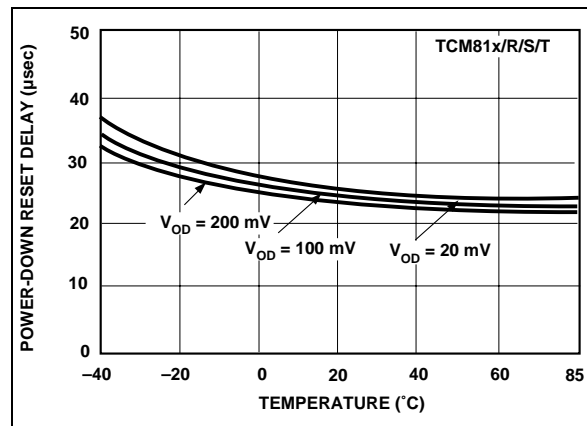

FIGURE 3-6: Power-Down Reset Delay vs. Temperature.

TCM811/TCM812

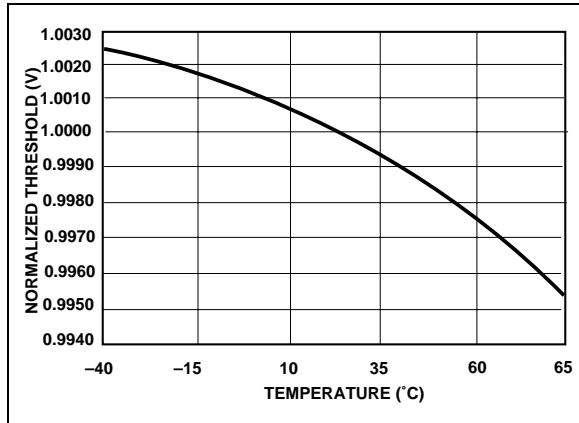
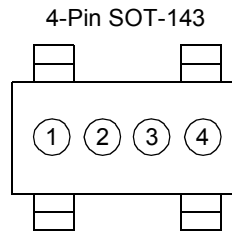

FIGURE 3-7: Normalized Reset Threshold vs. Temperature.

4.0 PACKAGING INFORMATION

4.1 Package Marking Information



Part Number	(V)	Code
TCM811LERC	4.63	U1
TCM811MERC	4.38	U2
TCM811TERC	3.08	U3
TCM811SERC	2.93	U4
TCM811RERC	2.63	U5
TCM811FERC	1.75	U7
TCM812LERC	4.63	V1
TCM812MERC	4.38	V2
TCM812TERC	3.08	V3
TCM812SERC	2.93	V4
TCM812RERC	2.63	V5
TCM812FERC	1.75	V7

Legend:	1	Part Number + temperature range and voltage (two-digit code)
	2	Part Number + temperature range and voltage (two-digit code)
	3	Year and two-month period code
	4	Lot ID number
Note:	In the event the full Microchip part number cannot be marked on one line, it will be carried over to the next line thus limiting the number of available characters for customer specific information.	

TCM811/TCM812

4.2 Package Dimensions

Component Taping Orientation for 4-Pin SOT-143 Devices

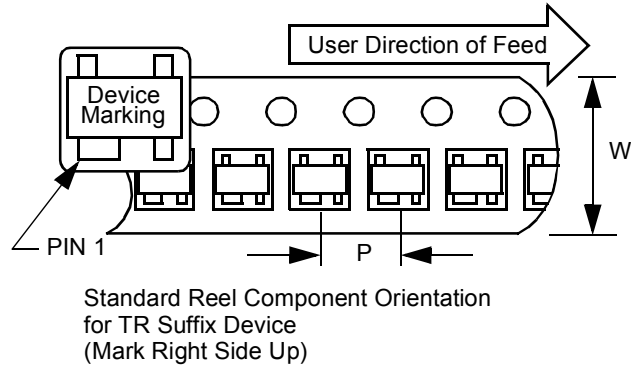

Carrier Tape, Number of Components Per Reel and Reel Size:

Package	Carrier Width (W)	Pitch (P)	Part Per Full Reel	Reel Size
4-Pin SOT-143	8 mm	4 mm	3000	7 in.

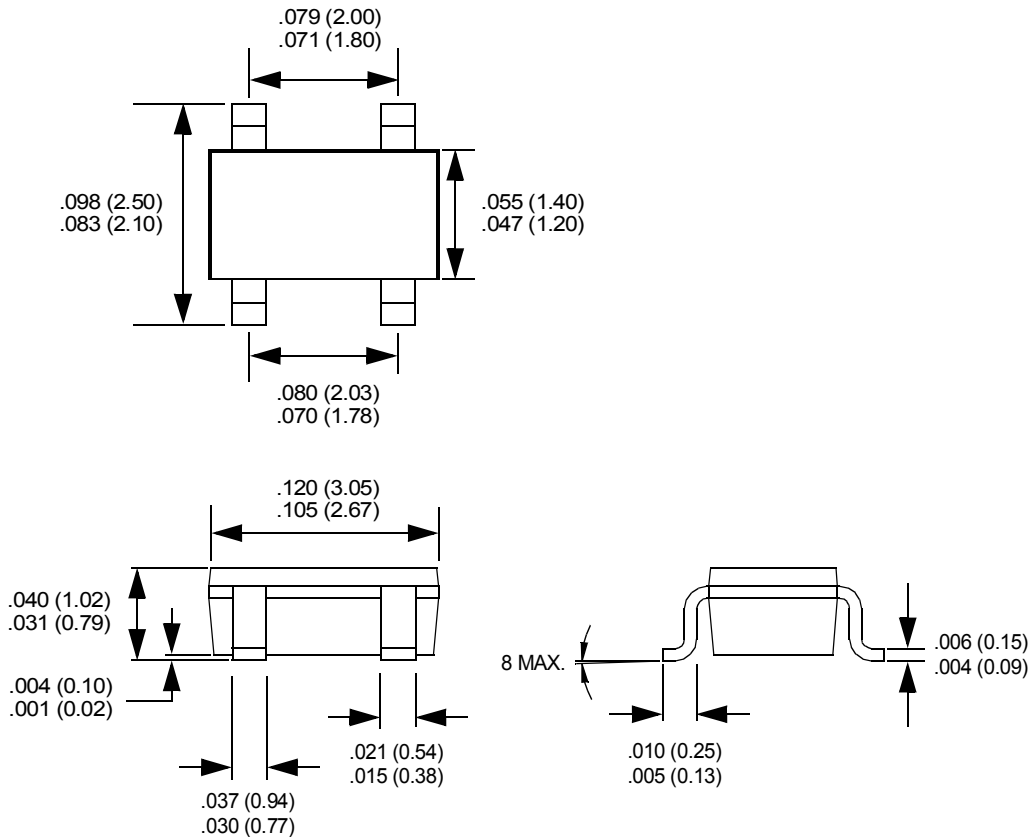

ON-LINE SUPPORT

Microchip provides on-line support on the Microchip World Wide Web (WWW) site.

The web site is used by Microchip as a means to make files and information easily available to customers. To view the site, the user must have access to the Internet and a web browser, such as Netscape or Microsoft Explorer. Files are also available for FTP download from our FTP site.

Connecting to the Microchip Internet Web Site

The Microchip web site is available by using your favorite Internet browser to attach to:

www.microchip.com

The file transfer site is available by using an FTP service to connect to:

<ftp://ftp.microchip.com>

The web site and file transfer site provide a variety of services. Users may download files for the latest Development Tools, Data Sheets, Application Notes, User's Guides, Articles and Sample Programs. A variety of Microchip specific business information is also available, including listings of Microchip sales offices, distributors and factory representatives. Other data available for consideration is:

- Latest Microchip Press Releases
- Technical Support Section with Frequently Asked Questions
- Design Tips
- Device Errata
- Job Postings
- Microchip Consultant Program Member Listing
- Links to other useful web sites related to Microchip Products
- Conferences for products, Development Systems, technical information and more
- Listing of seminars and events

Systems Information and Upgrade Hot Line

The Systems Information and Upgrade Line provides system users a listing of the latest versions of all of Microchip's development systems software products. Plus, this line provides information on how customers can receive any currently available upgrade kits. The Hot Line Numbers are:

1-800-755-2345 for U.S. and most of Canada, and
1-480-792-7302 for the rest of the world.

013001

TCM811/TCM812

READER RESPONSE

It is our intention to provide you with the best documentation possible to ensure successful use of your Microchip product. If you wish to provide your comments on organization, clarity, subject matter, and ways in which our documentation can better serve you, please FAX your comments to the Technical Publications Manager at (480) 792-4150.

Please list the following information, and use this outline to provide us with your comments about this Data Sheet.

To: Technical Publications Manager Total Pages Sent
RE: Reader Response
From: Name _____
Company _____
Address _____
City / State / ZIP / Country _____
Telephone: (_____) _____ - _____ FAX: (_____) _____ - _____

Application (optional):

Would you like a reply? ___Y ___N

Device: **TCM811/TCM812** Literature Number: **DS21615B**

Questions:

1. What are the best features of this document?

2. How does this document meet your hardware and software development needs?

3. Do you find the organization of this data sheet easy to follow? If not, why?

4. What additions to the data sheet do you think would enhance the structure and subject?

5. What deletions from the data sheet could be made without affecting the overall usefulness?

6. Is there any incorrect or misleading information (what and where)?

7. How would you improve this document?

8. How would you improve our software, systems, and silicon products?

PRODUCT IDENTIFICATION SYSTEM

To order or obtain information, e.g., on pricing or delivery, refer to the factory or the listed sales office.

<u>PART NO.</u>	<u>X</u>	<u>X</u>	<u>XXXX</u>
Device	V_{DD} Reset Threshold	Temperature Range	Package
Device:	TCM811: Supervisor Circuit with active-low <u>RESET</u> output TCM812: Supervisor Circuit with active-high <u>RESET</u> output		
V_{DD} Reset Threshold:	L = 4.63V M = 4.38V T = 3.08V S = 2.93V R = 2.63V F = 1.75V		
Temperature Range:	E = -40°C to +85°C		
Package:	RCTR = SOT-143, 4-pin (Tape and Reel)		

Examples:

a) TCM811LERCTR: SOT-143, Microcontroller
4.63V Reset Monitor, -40°C to +85°C, Tape and Reel.

b) TCM811MERCTR: SOT-143, Microcontroller
4.38V Reset Monitor, -40°C to +85°C, Tape and Reel.

a) TCM812FERCTR: SOT-143, Microcontroller
1.75V Reset Monitor, -40°C to +85°C, Tape and Reel.

b) TCM812SERCTR: SOT-143, Microcontroller
2.93V Reset Monitor, -40°C to +125°C, Tape and Reel.

Sales and Support

Data Sheets

Products supported by a preliminary Data Sheet may have an errata sheet describing minor operational differences and recommended workarounds. To determine if an errata sheet exists for a particular device, please contact one of the following:

1. Your local Microchip sales office
2. The Microchip Corporate Literature Center U.S. FAX: (480) 792-7277
3. The Microchip Worldwide Site (www.microchip.com)

Please specify which device, revision of silicon and Data Sheet (include Literature #) you are using.

New Customer Notification System

Register on our web site (www.microchip.com/cn) to receive the most current information on our products.

TCM811/TCM812

NOTES:

Information contained in this publication regarding device applications and the like is intended through suggestion only and may be superseded by updates. It is your responsibility to ensure that your application meets with your specifications. No representation or warranty is given and no liability is assumed by Microchip Technology Incorporated with respect to the accuracy or use of such information, or infringement of patents or other intellectual property rights arising from such use or otherwise. Use of Microchip's products as critical components in life support systems is not authorized except with express written approval by Microchip. No licenses are conveyed, implicitly or otherwise, under any intellectual property rights.

Trademarks

The Microchip name and logo, the Microchip logo, FilterLab, KEELOQ, MPLAB, PIC, PICmicro, PICMASTER, PICSTART, PRO MATE, SEEVAL and The Embedded Control Solutions Company are registered trademarks of Microchip Technology Incorporated in the U.S.A. and other countries.

dsPIC, ECONOMONITOR, FanSense, FlexROM, fuzzyLAB, In-Circuit Serial Programming, ICSP, ICEPIC, microID, microPort, Migratable Memory, MPASM, MPLIB, MPLINK, MPSIM, MXDEV, PICC, PICDEM, PICDEM.net, rPIC, Select Mode and Total Endurance are trademarks of Microchip Technology Incorporated in the U.S.A.

Serialized Quick Term Programming (SQTP) is a service mark of Microchip Technology Incorporated in the U.S.A.

All other trademarks mentioned herein are property of their respective companies.

© 2002, Microchip Technology Incorporated, Printed in the U.S.A., All Rights Reserved.

 Printed on recycled paper.

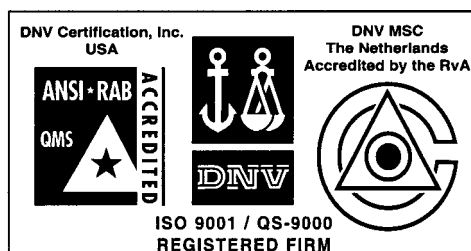

Microchip received QS-9000 quality system certification for its worldwide headquarters, design and wafer fabrication facilities in Chandler and Tempe, Arizona in July 1999. The Company's quality system processes and procedures are QS-9000 compliant for its PICmicro® 8-bit MCUs, KEELOQ® code hopping devices, Serial EEPROMs and microperipheral products. In addition, Microchip's quality system for the design and manufacture of development systems is ISO 9001 certified.



MICROCHIP

WORLDWIDE SALES AND SERVICE

AMERICAS

Corporate Office

2355 West Chandler Blvd.
Chandler, AZ 85224-6199
Tel: 480-792-7200 Fax: 480-792-7277
Technical Support: 480-792-7627
Web Address: <http://www.microchip.com>

Rocky Mountain

2355 West Chandler Blvd.
Chandler, AZ 85224-6199
Tel: 480-692-7966 Fax: 480-792-7456

Atlanta

500 Sugar Mill Road, Suite 200B
Atlanta, GA 30350
Tel: 770-640-0034 Fax: 770-640-0307

Boston

2 Lan Drive, Suite 120
Westford, MA 01886
Tel: 978-692-3848 Fax: 978-692-3821

Chicago

333 Pierce Road, Suite 180
Itasca, IL 60143
Tel: 630-285-0071 Fax: 630-285-0075

Dallas

4570 Westgrove Drive, Suite 160
Addison, TX 75001
Tel: 972-818-7423 Fax: 972-818-2924

Detroit

Tri-Atria Office Building
32255 Northwestern Highway, Suite 190
Farmington Hills, MI 48334
Tel: 248-538-2250 Fax: 248-538-2260

Kokomo

2767 S. Albright Road
Kokomo, Indiana 46902
Tel: 765-864-8360 Fax: 765-864-8387

Los Angeles

18201 Von Karman, Suite 1090
Irvine, CA 92612
Tel: 949-263-1888 Fax: 949-263-1338

New York

150 Motor Parkway, Suite 202
Hauppauge, NY 11788
Tel: 631-273-5305 Fax: 631-273-5335

San Jose

Microchip Technology Inc.
2107 North First Street, Suite 590
San Jose, CA 95131
Tel: 408-436-7950 Fax: 408-436-7955

Toronto

6285 Northam Drive, Suite 108
Mississauga, Ontario L4V 1X5, Canada
Tel: 905-673-0699 Fax: 905-673-6509

ASIA/PACIFIC

Australia

Microchip Technology Australia Pty Ltd
Suite 22, 41 Rawson Street
Epping 2121, NSW
Australia
Tel: 61-2-9868-6733 Fax: 61-2-9868-6755

China - Beijing

Microchip Technology Consulting (Shanghai)
Co., Ltd., Beijing Liaison Office
Unit 915
Bei Hai Wan Tai Bldg.
No. 6 Chaoyangmen Beidajie
Beijing, 100027, No. China
Tel: 86-10-85282100 Fax: 86-10-85282104

China - Chengdu

Microchip Technology Consulting (Shanghai)
Co., Ltd., Chengdu Liaison Office
Rm. 2401, 24th Floor,
Ming Xing Financial Tower
No. 88 TIDU Street
Chengdu 610016, China
Tel: 86-28-6766200 Fax: 86-28-6766599

China - Fuzhou

Microchip Technology Consulting (Shanghai)
Co., Ltd., Fuzhou Liaison Office
Unit 28F, World Trade Plaza
No. 71 Wusi Road
Fuzhou 350001, China
Tel: 86-591-7503506 Fax: 86-591-7503521

China - Shanghai

Microchip Technology Consulting (Shanghai)
Co., Ltd.
Room 701, Bldg. B
Far East International Plaza
No. 317 Xian Xia Road
Shanghai, 200051
Tel: 86-21-6275-5700 Fax: 86-21-6275-5060

China - Shenzhen

Microchip Technology Consulting (Shanghai)
Co., Ltd., Shenzhen Liaison Office
Rm. 1315, 13/F, Shenzhen Kerry Centre,
Renminnan Lu
Shenzhen 518001, China
Tel: 86-755-2350361 Fax: 86-755-2366086

Hong Kong

Microchip Technology Hongkong Ltd.
Unit 901-6, Tower 2, Metroplaza
223 Hing Fong Road
Kwai Fong, N.T., Hong Kong
Tel: 852-2401-1200 Fax: 852-2401-3431

India

Microchip Technology Inc.
India Liaison Office
Divyasree Chambers
1 Floor, Wing A (A3/A4)
No. 11, O'Shaughnessey Road
Bangalore, 560 025, India
Tel: 91-80-2290061 Fax: 91-80-2290062

Japan

Microchip Technology Japan K.K.
Benex S-1 6F
3-18-20, Shinyokohama
Kohoku-Ku, Yokohama-shi
Kanagawa, 222-0033, Japan
Tel: 81-45-471-6166 Fax: 81-45-471-6122

Korea

Microchip Technology Korea
168-1, Youngbo Bldg. 3 Floor
Samsung-Dong, Kangnam-Ku
Seoul, Korea 135-882
Tel: 82-2-554-7200 Fax: 82-2-558-5934

Singapore

Microchip Technology Singapore Pte Ltd.
200 Middle Road
#07-02 Prime Centre
Singapore, 188980
Tel: 65-334-8870 Fax: 65-334-8850

Taiwan

Microchip Technology Taiwan
11F-3, No. 207
Tung Hua North Road
Taipei, 105, Taiwan
Tel: 886-2-2717-7175 Fax: 886-2-2545-0139

EUROPE

Denmark

Microchip Technology Nordic ApS
Regus Business Centre
Lautrup høj 1-3
Ballerup DK-2750 Denmark
Tel: 45 4420 9895 Fax: 45 4420 9910

France

Microchip Technology SARL
Parc d'Activite du Moulin de Massy
43 Rue du Saule Trapu
Batiment A - 1er Etage
91300 Massy, France
Tel: 33-1-69-53-63-20 Fax: 33-1-69-30-90-79

Germany

Microchip Technology GmbH
Gustav-Heinemann Ring 125
D-81739 Munich, Germany
Tel: 49-89-627-144 0 Fax: 49-89-627-144-44

Italy

Microchip Technology SRL
Centro Direzionale Colleoni
Palazzo Taurus 1 V. Le Colleoni 1
20041 Agrate Brianza
Milan, Italy
Tel: 39-039-65791-1 Fax: 39-039-6899883

United Kingdom

Arizona Microchip Technology Ltd.
505 Eskdale Road
Winnersh Triangle
Wokingham
Berkshire, England RG41 5TU
Tel: 44 118 921 5869 Fax: 44-118 921-5820

01/18/02

