

TCA9509 Level-Translating I²C and SMBUS Bus Repeater

1 Features

- Two-Channel Bidirectional Buffer
- I²C Bus and SMBus Compatible
- Operating Supply Voltage Range of 2.7 V to 5.5 V on B side
- Operating Voltage Range of 0.9 V to 5.5 V on A-Side
- Voltage-Level Translation From 0.9 V to 5.5 V and 2.7 V to 5.5 V
- Active-High Repeater-Enable Input
- Requires No External Pullup Resistors on Lower-Voltage Port-A
- Open-Drain I²C I/O
- 5.5-V Tolerant I²C and Enable Input Support Mixed-Mode Signal Operation
- Lockup-Free Operation
- Accommodates Standard Mode and Fast Mode I²C Devices and Multiple Masters
- Supports Arbitration and Clock Stretching Across Repeater
- Powered-Off High-Impedance I²C Bus Pins
- Supports 400-kHz Fast I²C Bus Operating Speeds
- Available in
 - 1.6-mm x 1.6-mm, 0.4-mm height, 0.5-mm Pitch QFN Package
 - 3-mm x 3-mm Industry Standard MSOP Package
- Latch-Up Performance Exceeds 100 mA Per JESD 78, Class II
- ESD Protection Exceeds JESD 22
 - 2000-V Human-Body Model (A114-A)
 - 1000-V Charged-Device Model (C101)

2 Applications

- Servers
- Routers (Telecom Switching Equipment)
- Industrial Equipment
- Products with many I²C slaves and/or long PCB Traces

3 Description

This TCA9509 integrated circuit is an I²C bus/SMBus Repeater for use in I²C/SMBus systems. It can also provide bidirectional voltage-level translation (up-translation/down-translation) between low voltages (down to 0.9 V) and higher voltages (2.7 V to 5.5 V) in mixed-mode applications. This device enables I²C and similar bus systems to be extended, without degradation of performance even during level shifting.

The TCA9509 buffers both the serial data (SDA) and the serial clock (SCL) signals on the I²C bus, thus allowing 400-pF bus capacitance on the B-side. This device can also be used to isolate two halves of a bus for voltage and capacitance.

The TCA9509 has two types of drivers – A-side drivers and B-side drivers. All inputs and B-side I/Os are overvoltage tolerant to 5.5 V. The A-side I/Os are overvoltage tolerant to 5.5 V when the device is unpowered (V_{CCB} and/or V_{CCA} = 0 V).

Device Information⁽¹⁾

PART NUMBER	PACKAGE	BODY SIZE (NOM)
TCA9509	VSSOP (8)	3.00 mm x 3.00 mm
	X2QFN (8)	1.60 mm x 1.60 mm

(1) For all available packages, see the orderable addendum at the end of the data sheet.

Simplified Schematic

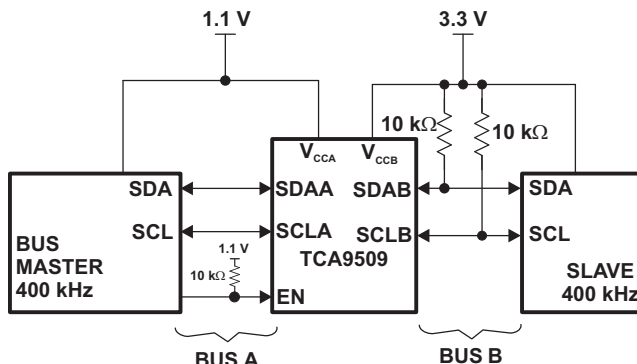

Copyright © 2017, Texas Instruments Incorporated



Table of Contents

1 Features	1	9.2 Functional Block Diagram	8
2 Applications	1	9.3 Feature Description	9
3 Description	1	9.4 Device Functional Modes	9
4 Revision History	2	10 Application and Implementation	10
5 Description (continued)	3	10.1 Application Information	10
6 Pin Configuration or Functions	3	10.2 Typical Application	10
7 Specifications	4	11 Power Supply Recommendations	13
7.1 Absolute Maximum Ratings	4	12 Layout	14
7.2 ESD Ratings	4	12.1 Layout Guidelines	14
7.3 Recommended Operating Conditions	4	12.2 Layout Example	14
7.4 Thermal Information	5	13 Device and Documentation Support	15
7.5 Electrical Characteristics	5	13.1 Receiving Notification of Documentation Updates	15
7.6 Timing Requirements	5	13.2 Community Resources	15
7.7 I ² C Interface Timing Requirements	6	13.3 Trademarks	15
8 Parameter Measurement Information	7	13.4 Electrostatic Discharge Caution	15
9 Detailed Description	8	13.5 Glossary	15
9.1 Overview	8	14 Mechanical, Packaging, and Orderable Information	15

4 Revision History

NOTE: Page numbers for previous revisions may differ from page numbers in the current version.

Changes from Revision B (January 2012) to Revision C	Page
• Added ESD Ratings table, Feature Description section, Device Functional Modes, Application and Implementation section, Power Supply Recommendations section, Layout section, Device and Documentation Support section, and Mechanical, Packaging, and Orderable Information section.	1
• Added junction temperature to the Absolute Maximum Ratings	4
• Changed thermal information for RVH and DGK packages	5
• Changed V _{I_{ILC}} , added Test Conditions with new MIN and TYP values in the Electrical Characteristics table	5
• Updated Bus A (0.9-V to 5.5-V Bus) Waveform	6
• Updated Bus B (2.7-V to 5.5-V Bus) Waveform	6

Changes from Revision A (October 2011) to Revision B	Page
• Added DGK package and package information to datasheet.	1

Changes from Original (August 2011) to Revision A	Page
• Corrected V _{CCA} operating voltage lower limit, to 0.9V at multiple instances in document.	1
• Changed Operating Supply Voltage Range value error in FEATURES for B side. Changed from (0.9 V to 5.5 V on B side) to (2.7 V to 5.5 V on B side).	1
• Changed Operating Voltage Range value error in FEATURES for A side. Changed (2.7 V to V _{CCB} – 1 V on A side) to (0.9 V to V _{CCB} – 1 V on A side).	1

5 Description (continued)

The bus port B drivers are compliant with SMBus I/O levels, while the A-side uses a current sensing mechanism to detect the input or output LOW signal which prevents bus lock-up. The A-side uses a 1 mA current source for pull-up and a 200 Ω pull-down driver. This results in a LOW on the A-side accommodating smaller voltage swings. The output pull-down on the A-side internal buffer LOW is set for approximately 0.2 V, while the input threshold of the internal buffer is set about 50 mV lower than that of the output voltage LOW. When the A-side I/O is driven LOW internally, the LOW is not recognized as a LOW by the input. This prevents a lock-up condition from occurring. The output pull-down on the B-side drives a hard LOW and the input level is set at 0.3 of SMBus or I²C-bus voltage level which enables B side to connect to any other I²C-bus devices or buffer.

The TCA9509 drivers are not enabled unless V_{CCA} is above 0.8 V and V_{CCB} is above 2.5 V. The enable (EN) pin can also be used to turn the drivers on and off under system control. Caution should be observed to only change the state of the EN pin when the bus is idle.

6 Pin Configuration or Functions



Pin Functions

PIN		I/O	DESCRIPTION
NAME	NO.		
V_{CCA}	1	Supply	A-side supply voltage (0.9 V to 5.5 V)
SCLA	2	I/O	Serial clock bus, A side.
SDAA	3	I/O	Serial data bus, A side.
GND	4	Supply	Supply ground
EN	5	Input	Active-high repeater enable input
SDAB	6	I/O	Serial data bus, B side. Connect to V_{CCB} through a pull-up resistor.
SCLB	7	I/O	Serial clock bus, B side. Connect to V_{CCB} through a pull-up resistor.
V_{CCB}	8	Supply	B-side and device supply voltage (2.7 V to 5.5 V)
Thermal Attach Pad	-	-	Thermal Attach Pad is not electrically connected and it is recommended to be attached to GND for best thermal performance. This is for the RVH package only.

7 Specifications

7.1 Absolute Maximum Ratings

over operating free-air temperature range (unless otherwise noted)⁽¹⁾

		MIN	MAX	UNIT
V _{CCB}	Supply voltage	-0.5	6	V
V _{CCA}	Supply voltage	-0.5	6	V
V _I	Enable input voltage ⁽²⁾	-0.5	6	V
V _{I/O}	I ² C bus voltage ⁽²⁾	-0.5	6	V
I _{IK}	Input clamp current	V _I < 0	-20	mA
I _{OK}	Output clamp current	V _O < 0	-20	
P _d	Max power dissipation		100	mW
T _J	Junction temperature		125	°C
T _{stg}	Storage temperature	-65	150	°C

- (1) Stresses beyond those listed under "absolute maximum ratings" may cause permanent damage to the device. These are stress ratings only, and functional operation of the device at these or any other conditions beyond those indicated under "recommended operating conditions" is not implied. Exposure to absolute-maximum-rated conditions for extended periods may affect device reliability.
- (2) The input negative-voltage and output voltage ratings may be exceeded if the input and output current ratings are observed.

7.2 ESD Ratings

		VALUE	UNIT
V _(ESD)	Electrostatic discharge	Human-body model (HBM), per ANSI/ESDA/JEDEC JS-001 ⁽¹⁾	±2000
		Charged-device model (CDM), per JEDEC specification JESD22-C101 ⁽²⁾	±1000

- (1) JEDEC document JEP155 states that 500-V HBM allows safe manufacturing with a standard ESD control process.
- (2) JEDEC document JEP157 states that 250-V CDM allows safe manufacturing with a standard ESD control process.

7.3 Recommended Operating Conditions

		MIN	MAX	UNIT
V _{CCA}	Supply voltage, A-side bus	0.9 ⁽¹⁾	5.5	V
V _{CCB}	Supply voltage, B-side bus	2.7	5.5	V
V _{IH}	High-level input voltage	SDAA, SCLA	0.7 × V _{CCA}	V _{CCA}
		SDAB, SCLB	0.7 × V _{CCB}	5.5
		EN	0.7 × V _{CCA}	5.5
V _{IL}	Low-level input voltage	SDAA, SCLA	-0.5	0.3
		SDAB, SCLB	-0.5	0.3 × V _{CCB}
		EN	-0.5	0.3 × V _{CCA}
I _{OL}	Low-level output current	SDAA, SCLA	10	μA
		SDAB, SCLB	6	mA
T _A	Operating free-air temperature	-40	85	°C

- (1) Low-level supply voltage

7.4 Thermal Information

THERMAL METRIC ⁽¹⁾		TCA9509		UNIT
		RVH (X2QFN)	DGK (VSSOP)	
		8 PINS	8 PINS	
R _{θJA}	Junction-to-ambient thermal resistance ⁽²⁾	160.3	222.9	°C/W
R _{θJC(top)}	Junction-to-case (top) thermal resistance	66.4	109.5	°C/W
R _{θJB}	Junction-to-board thermal resistance	115.9	144.5	°C/W
ψ _{JT}	Junction-to-top characterization parameter	0.8	34.5	°C/W
ψ _{JB}	Junction-to-board characterization parameter	116.2	142.7	°C/W
R _{θJC(bot)}	Junction-to-case (bottom) thermal resistance	80.5	n/a	°C/W

(1) For more information about traditional and new thermal metrics, see the [Semiconductor and IC Package Thermal Metrics](#) application report.

(2) The package thermal impedance is calculated in accordance with JESD 51-7.

7.5 Electrical Characteristics

V_{CCB} = 2.7 V to 5.5 V, V_{CCA} = 0.9 V to (V_{CCB}-1), T_A = -40°C to 85°C (unless otherwise noted)

PARAMETER		TEST CONDITIONS	MIN	TYP	MAX	UNIT
V _{IK}	Input clamp voltage	I _I = -18 mA	-1.5		-0.5	V
V _{OL}	Low-level output voltage	SDAA, SCLA I _{OL} = 10 μA, V _{ILA} = V _{ILB} = 0 V, V _{CCA} = 0.9 to 1.2 V		0.18	0.25	V
		SDAA, SCLA I _{OL} = 20 μA, V _{ILA} = V _{ILB} = 0 V, 1.2V < V _{CCA} ≤ (V _{CCB} - 1 V)		0.2	0.3	
V _{OL} - V _{ILc}	Low-level input voltage below low-level output voltage	SDAA, SCLA		50		mV
V _{ILc}	SDA and SCL low-level input voltage contention	SDAA, SCLA V _{CCA} ≥ 1.5 V and V _{CCB} ≥ 3.15 V	110	150		mV
		SDAA, SCLA V _{CCA} < 1.5 V or V _{CCB} < 3.15 V	50	100		
V _{OLB}	Low-level output voltage	SDAB, SCLB I _{OL} = 6 mA		0.1	0.2	V
I _{CC}	Quiescent supply current for V _{CCA}	All port A Static high	0.25	0.45	0.9	mA
		All port A Static low	1.25			
I _{CC}	Quiescent supply current for V _{CCB}	All port B Static high	0.5	0.9	1.1	mA
I _I	Input leakage current	SDAB, SCLB V _I = V _{CCB}			±1	μA
			SDAA, SCLA V _I = V _{CCA}			
		EN V _I = V _{CCB}				
			SDAB, SCLB V _O = 3.6 V			
		SDAA, SCLA V _O = 3.6 V				
I _{OH}	High-level output leakage current	SDAB, SCLB SDAA, SCLA V _O = 3.6 V			10	μA
C _{IOA}	I/O capacitance of A-side	SCLA, SDAA V _I = 0 V		6.5	7	pF
C _{IOB}	I/O capacitance of B-side	SCLB, SDAB V _I = 0 V	5.5		6.2	pF

7.6 Timing Requirements

over recommended operating free-air temperature range (unless otherwise noted)

		MIN	MAX	UNIT
t _{SU}	Setup time, EN high before Start condition ⁽¹⁾	100		ns
t _H	Hold time, EN high after Stop condition ⁽¹⁾	100		ns

(1) EN should change state only when the global bus and the repeater port are in an idle state.

7.7 I²C Interface Timing Requirements

 $T_A = -40^{\circ}\text{C}$ to 85°C (unless otherwise noted)

PARAMETER		V_{CCA} (INPUT)	V_{CCB} (OUTPUT)	TEST CONDITIONS	MIN	TYP ⁽¹⁾	MAX	UNIT	
t_{PHL}	Propagation delay	port A to port B	1.9 V	5 V	EN High	123.1	127.2	132.8	ns
		port B to port A				88.1	88.8	89.8	
t_{PLH}	Propagation delay	port A to port B	1.9 V	5 V	EN High	122.6	125.7	131.7	ns
		port B to port A				123	124.1	126.9	
t_{rise}	Transition time	port A	1.9 V	5 V	EN High	40.1	40.9	41.9	ns
		port B				57.3	57.5	58.4	
t_{fall}	Transition time	port A	1.9 V	5 V	EN High	14.5	16.4	17.9	ns
		port B				18.7	19.4	20.2	
t_{PLH2}	Propagation delay 50% of initial low on Port A to 1.5 V on Port B	port A to port B	1.9 V	5 V		176	177.3	178	ns
f_{MAX}	Maximum switching frequency					400			KHz

(1) Typical values were measured with $V_{CCA} = V_{CCB} = 2.7\text{ V}$ at $T_A = 25^{\circ}\text{C}$, unless otherwise noted.

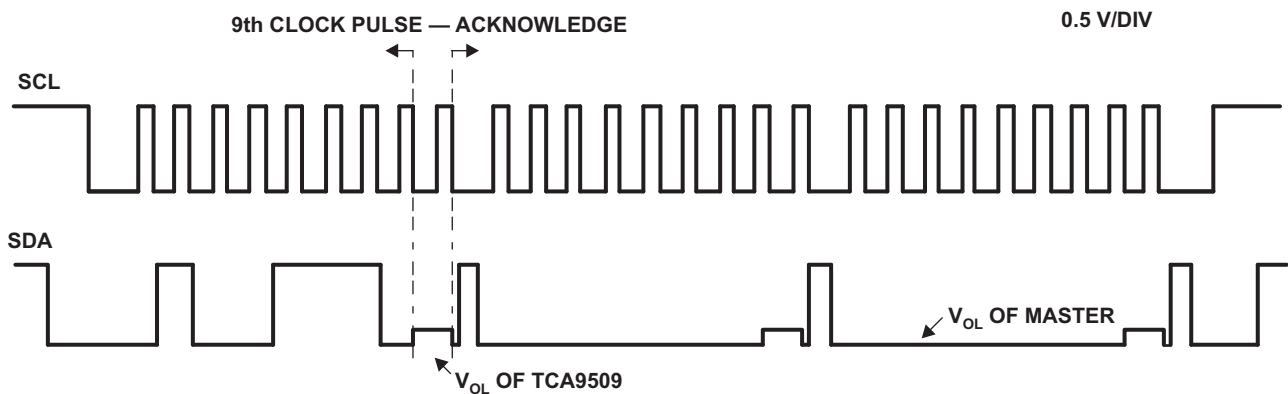

Figure 1. Bus A (0.9-V to 5.5-V Bus) Waveform

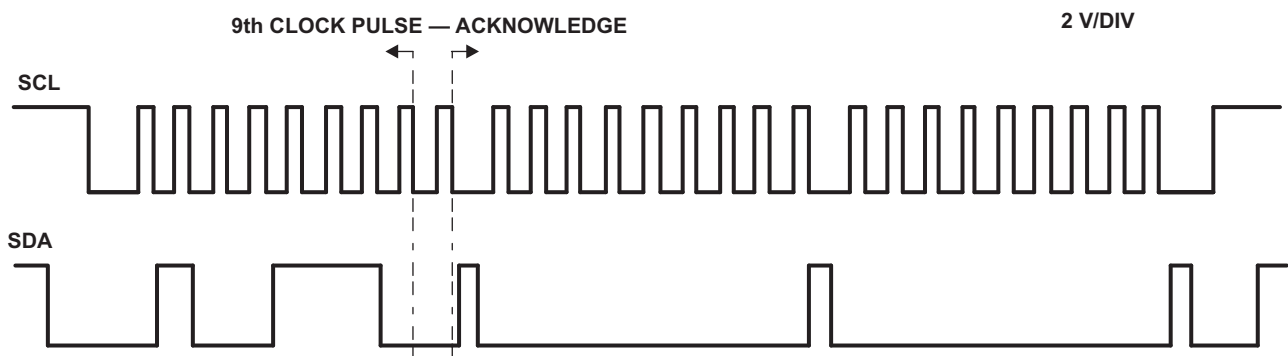
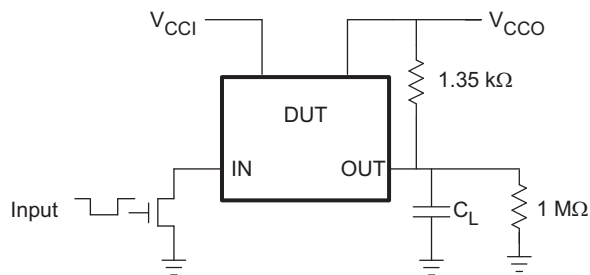
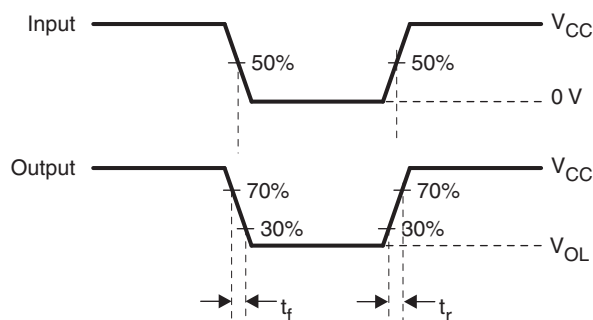

Figure 2. Bus B (2.7-V to 5.5-V Bus) Waveform

8 Parameter Measurement Information



PIN	C _L
SCLA, SDAA (A-side)	50 pF
SDAB, SCLB (B-side)	50 pF



- R_T termination resistance should be equal to Z_{OUT} of pulse generators.
- C_L includes probe and jig capacitance.
- All input pulses are supplied by generators having the following characteristics: PRR ≤ 10 MHz, Z_O = 50 Ω, slew rate ≥ 1 V/ns.
- The outputs are measured one at a time, with one transition per measurement.
- t_{PLH} and t_{PHL} are the same as t_{pd}.

Figure 3. Test Circuit and Voltage Waveforms

9 Detailed Description

9.1 Overview

This TCA9509 integrated circuit is an I²C bus/SMBus Repeater for use in I²C/SMBus systems. It can also provide bidirectional voltage-level translation (up-translation/down-translation) between low voltages (down to 0.9 V) and higher voltages (2.7 V to 5.5 V) in mixed-mode applications. This device enables I²C and similar bus systems to be extended, without degradation of performance even during level shifting.

The TCA9509 buffers both the serial data (SDA) and the serial clock (SCL) signals on the I²C bus, thus allowing 400-pF bus capacitance on the B-side. This device can also be used to isolate two halves of a bus for voltage and capacitance.

The TCA9509 has two types of drivers – A-side drivers and B-side drivers. All inputs and B-side I/O's are overvoltage tolerant to 5.5V. The A-side I/O's are overvoltage tolerant to 5.5 V when the device is unpowered (V_{CCB} and/or $V_{CCA} = 0V$).

9.2 Functional Block Diagram

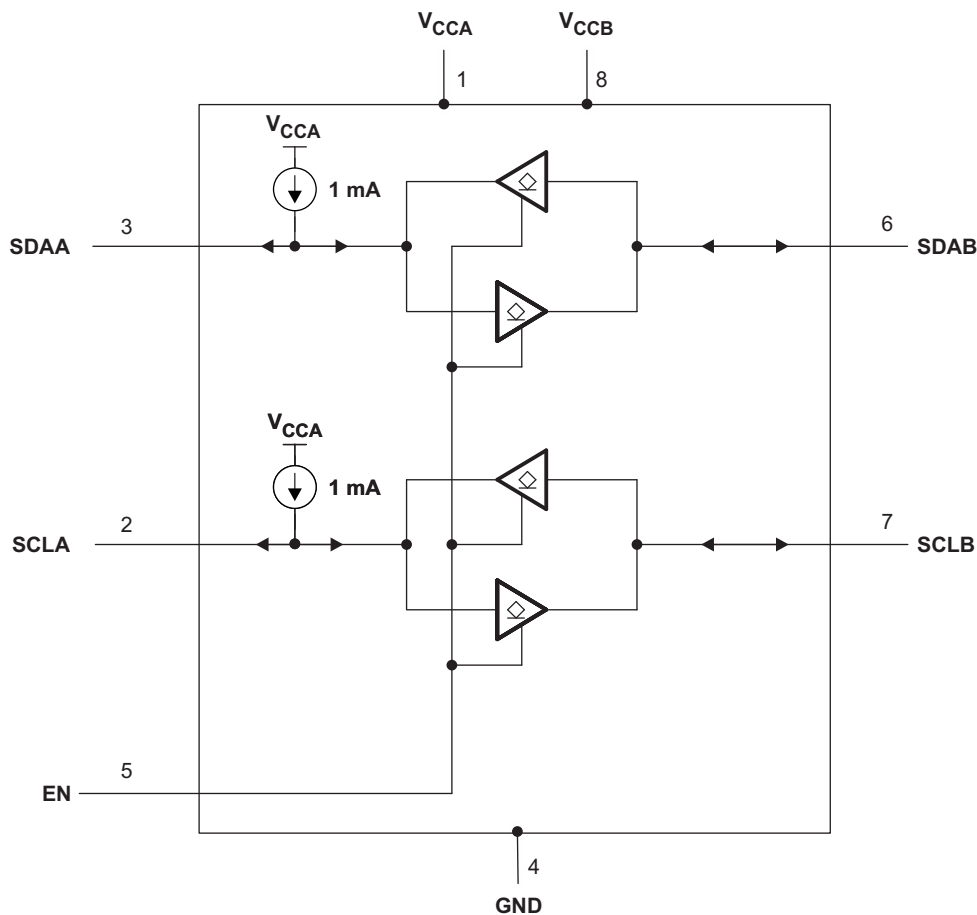

Copyright © 2017, Texas Instruments Incorporated

9.3 Feature Description

9.3.1 Two-Channel Bidirectional Buffer

The TCA9509 is a two-channel bidirectional buffer with level-shifting capabilities, featuring an integrated current source on the A-side.

9.3.2 Integrated A-Side Current Source

The A-side ports of the TCA9509 feature an integrated 1 mA current source, eliminating the need for external pull-up resistors on SDAA and SCLA.

9.3.3 Standard Mode and Fast Mode Support

The TCA9509 supports standard mode as well as fast mode I²C. The maximum system operating frequency will depend on system design and delays added by the repeater.

9.4 Device Functional Modes

[Table 1](#) lists the functional modes for the TCA9509.

Table 1. Function Table

INPUT EN	FUNCTION
L	Outputs disabled
H	SDAA = SDAB SCLA = SCLB

10 Application and Implementation

NOTE

Information in the following applications sections is not part of the TI component specification, and TI does not warrant its accuracy or completeness. TI's customers are responsible for determining suitability of components for their purposes. Customers should validate and test their design implementation to confirm system functionality.

10.1 Application Information

The TCA9509 is 5-V tolerant, so it does not require any additional circuitry to translate between 0.9-V to 5.5-V bus voltages and 2.7-V to 5.5-V bus voltages.

When the B-side of the TCA9509 is pulled low by a driver on the I²C bus and the falling edge goes below 0.3 V_{CCB}, it causes the internal driver on the A-side to turn on, causing the A-side to pull down to about 0.2 V (V_{OL}). When the A-side of the TCA9509 falls, a comparator detects the falling edge and causes the internal driver on the B-side to turn on and pull the B-side pin down to ground. In order to illustrate what would be seen in a typical application, refer to Figure 1. If the bus master in Figure 4 were to write to the slave through the TCA9509, waveforms shown in Figure 2 would be observed on the B bus. This looks like a normal I²C bus transmission, except that the high level may be as low as 0.9 V, and the turn on and turn off of the acknowledge signals are slightly delayed.

On the A-side bus of the TCA9509, the clock and data lines would have a positive offset from ground equal to the V_{OL} of the TCA9509. After the eighth clock pulse, the data line is pulled to the V_{OL} of the master device, which is close to ground in this example. At the end of the acknowledge, the level rises only to the low level set by the driver in the TCA9509 for a short delay, while the B-bus side rises above 0.3 V_{CCB} and then continues high. It is important to note that any arbitration or clock stretching events require that the low level on the A-bus side at the input of the TCA9509 (V_{IL}) be at or below V_{ILC} to be recognized by the TCA9509 and then transmitted to the B-bus side.

10.2 Typical Application

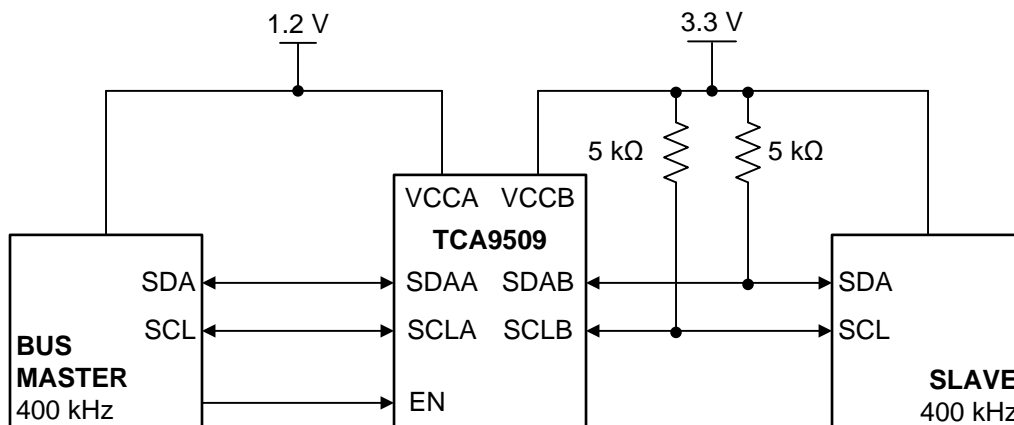

Copyright © 2017, Texas Instruments Incorporated

Figure 4. Typical Application, A-side Connected to Master

10.2.1 Design Requirements

A typical application is shown in Figure 4. In this example, the system master is running on a 1.2-V I²C bus, and the slave is connected to a 3.3-V bus. Both buses run at 400 kHz. Master devices can be placed on either bus. For the level translating application, the following should be true: $V_{CCA} \leq (V_{CCB} - 1\text{ V})$

- V_{CCA} = 0.9 V to 5.5 V
- V_{CCB} = 2.7 to 5.5 V
- A-side ports must not be connected together
- Pullup resistors should not be placed on the A-side ports

Typical Application (continued)

10.2.2 Detailed Design Procedure

10.2.2.1 Clock Stretching Support

The TCA9509 can support clock stretching, but care needs to be taken to minimize the overshoot voltage presented during the hand-off between the slave and master. This is best done by increasing the pull-up resistor value on B-side ports.

10.2.2.2 V_{ILC} and Pulldown Strength Requirements

For the TCA9509 to function correctly, all devices on the A-side must be able to pull the A-side below the voltage input low contention level (V_{ILC}). This means that the V_{OL} of any device on the A-side must be below V_{ILC} min.

The V_{OL} can be adjusted by changing the I_{OL} through the device which is set by the pull-up resistance value. The pull-up resistance on the A-side must be carefully selected to ensure that the logic levels will be transferred correctly to the B-side.

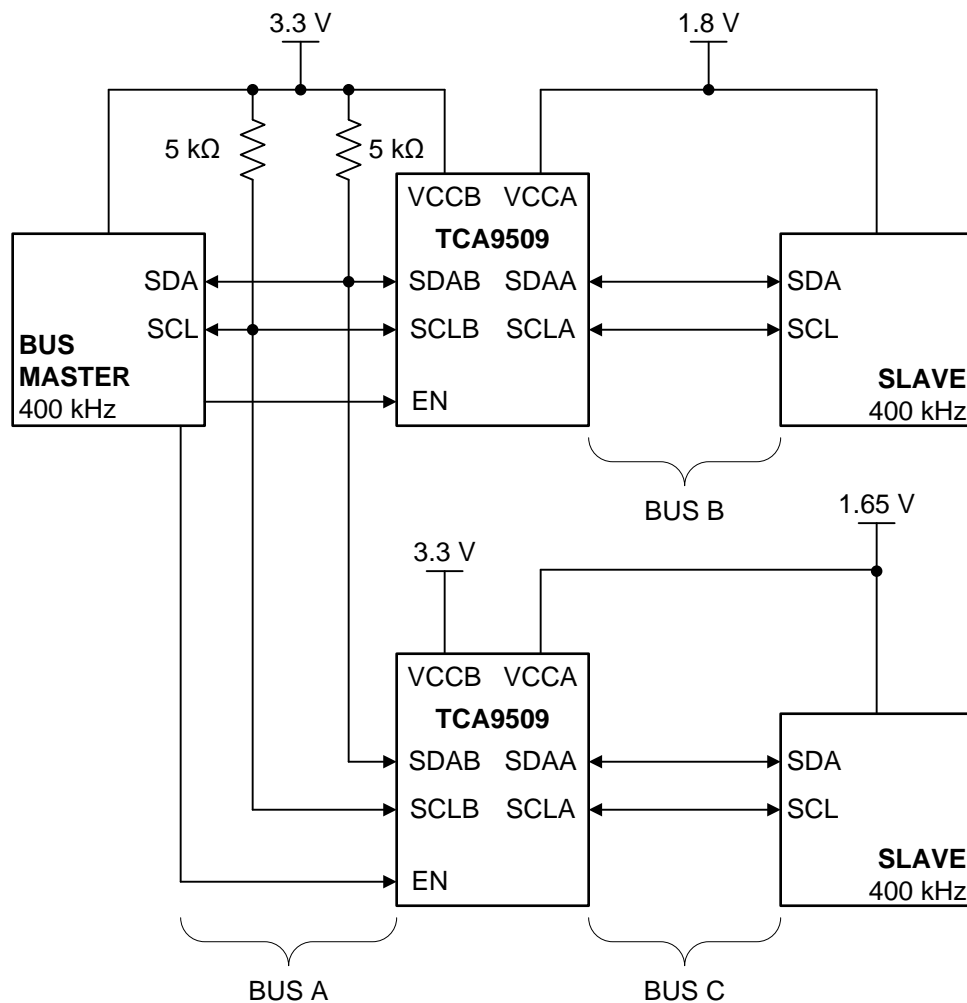

Copyright © 2017, Texas Instruments Incorporated

Figure 5. Typical Star Application

Multiple B-sides of TCA9509 s can be connected in a star configuration, allowing all nodes to communicate with each other. The A-sides should not be connected together when used in a star/parallel configuration.

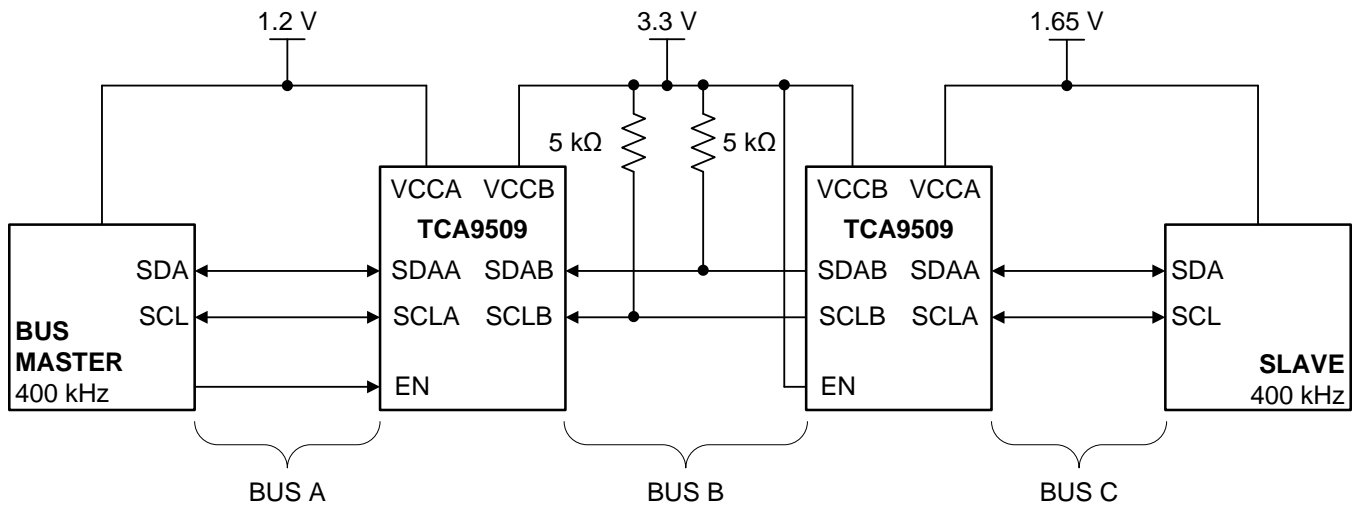
Typical Application (continued)

Copyright © 2017, Texas Instruments Incorporated

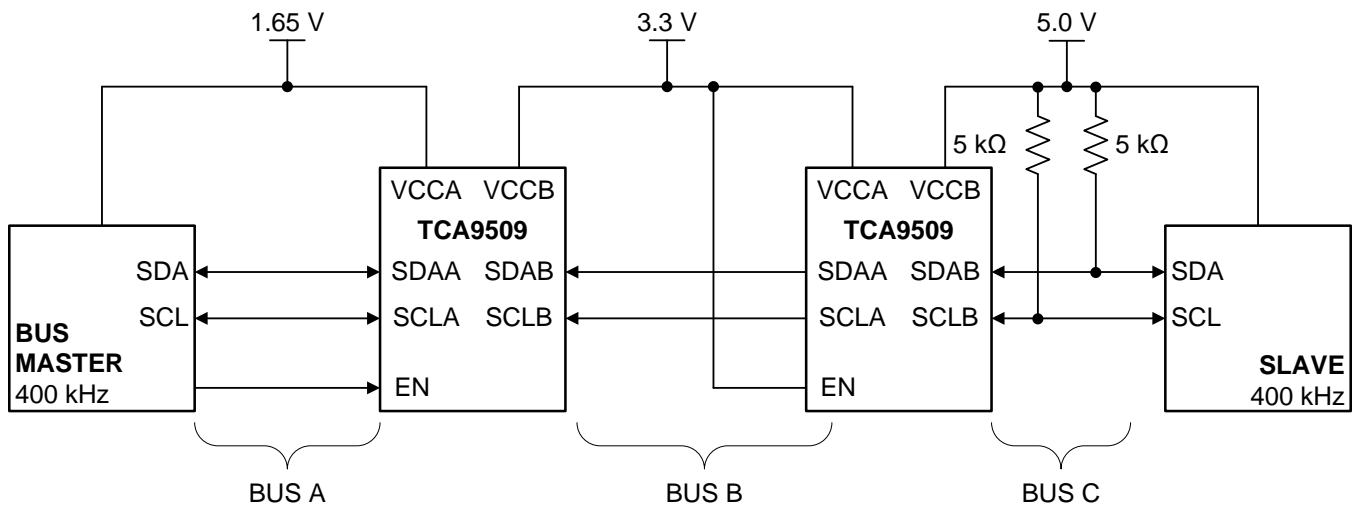
Figure 6. Typical Series Application, Two B-Sides Connected Together

Copyright © 2017, Texas Instruments Incorporated

Figure 7. Typical Series Application, A-side Connected to B-Side

To further extend the I²C bus for long traces/cables, multiple TCA9509 devices can be connected in series as long as the A-side is connected to the B-side and $V_{CCA} \leq (V_{CCB} - 1\text{ V})$ must also be met. Series connections can also be made by connecting both B-sides together while following power supply rule $V_{CCA} \leq (V_{CCB} - 1\text{ V})$. I²C bus slave devices can be connected to any of the bus segments. The number of devices that can be connected in series is limited by repeater delay/time-of-flight considerations on the maximum bus speed requirements.

11 Power Supply Recommendations

V_{CCB} and V_{CCA} can be applied in any sequence at power up. The TCA9509 includes a power-up circuit that keeps the output drivers turned off until V_{CCB} is above 2.5 V and the V_{CCA} is above 0.8 V. After power up and with the EN high, a low level on the B-side (below $0.3 \times V_{CCB}$) turns the corresponding A-side driver (either SDA or SCL) on and drives the A-side down to approximately 0.2 V. When the B-side rises above $0.3 \times V_{CCB}$, the A-side pull-down driver is turned off and the external pull-up resistor pulls the pin high. When the A-side falls first and goes below $0.3 \times V_{CCA}$, the B-side driver is turned on and the B-side pulls down to 0 V. The A-side pull-down is not enabled unless the A-side voltage goes below 0.4 V. If the A-side low voltage does not go below 0.5 V, the B-side driver turns off when the A-side voltage is above $0.7 \times V_{CCA}$. If the A-side low voltage goes below 0.4 V, the A-side pull-down driver is enabled, and the A-side is able to rise to only 0.5 V until the B-side rises above $0.3 \times V_{CCB}$.

A 100nF a decoupling capacitor should be placed as close to the V_{CCA} and V_{CCB} pins in order to provide proper filtering of supply noise.

12 Layout

12.1 Layout Guidelines

There are no special layout procedures required for the TCA9509.

It is recommended that the decoupling capacitors be placed as close to the VCC pins as possible.

12.2 Layout Example

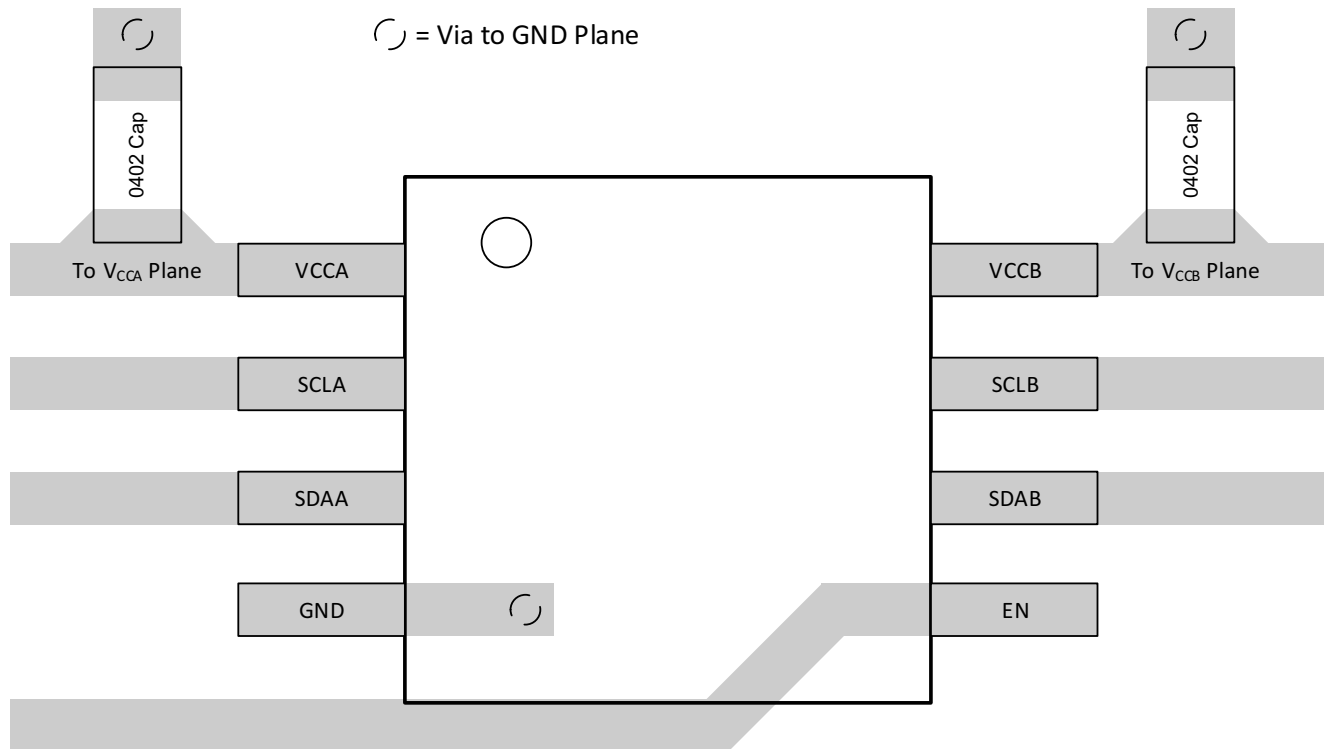

Figure 8. Example Layout

13 Device and Documentation Support

13.1 Receiving Notification of Documentation Updates

To receive notification of documentation updates, navigate to the device product folder on ti.com. In the upper right corner, click on *Alert me* to register and receive a weekly digest of any product information that has changed. For change details, review the revision history included in any revised document.

13.2 Community Resources

The following links connect to TI community resources. Linked contents are provided "AS IS" by the respective contributors. They do not constitute TI specifications and do not necessarily reflect TI's views; see TI's [Terms of Use](#).

TI E2E™ Online Community *TI's Engineer-to-Engineer (E2E) Community*. Created to foster collaboration among engineers. At e2e.ti.com, you can ask questions, share knowledge, explore ideas and help solve problems with fellow engineers.

Design Support *TI's Design Support* Quickly find helpful E2E forums along with design support tools and contact information for technical support.

13.3 Trademarks

E2E is a trademark of Texas Instruments.
All other trademarks are the property of their respective owners.

13.4 Electrostatic Discharge Caution



These devices have limited built-in ESD protection. The leads should be shorted together or the device placed in conductive foam during storage or handling to prevent electrostatic damage to the MOS gates.

13.5 Glossary

[SLYZ022](#) — *TI Glossary*.

This glossary lists and explains terms, acronyms, and definitions.

14 Mechanical, Packaging, and Orderable Information

The following pages include mechanical, packaging, and orderable information. This information is the most current data available for the designated devices. This data is subject to change without notice and revision of this document. For browser-based versions of this data sheet, refer to the left-hand navigation.

PACKAGING INFORMATION

Orderable Device	Status (1)	Package Type	Package Drawing	Pins	Package Qty	Eco Plan (2)	Lead/Ball Finish (6)	MSL Peak Temp (3)	Op Temp (°C)	Device Marking (4/5)	Samples
TCA9509DGKR	ACTIVE	VSSOP	DGK	8	2500	Green (RoHS & no Sb/Br)	CU NIPDAUAG	Level-1-260C-UNLIM	-40 to 85	(7KO, 7KQ)	Samples
TCA9509MRVHR	ACTIVE	X2QFN	RVH	8	5000	Green (RoHS & no Sb/Br)	CU NIPDAU	Level-1-260C-UNLIM	-40 to 85	7K	Samples
TCA9509RVHR	ACTIVE	X2QFN	RVH	8	5000	Green (RoHS & no Sb/Br)	CU NIPDAU	Level-1-260C-UNLIM	-40 to 85	7K	Samples

(1) The marketing status values are defined as follows:

ACTIVE: Product device recommended for new designs.

LIFEBUY: TI has announced that the device will be discontinued, and a lifetime-buy period is in effect.

NRND: Not recommended for new designs. Device is in production to support existing customers, but TI does not recommend using this part in a new design.

PREVIEW: Device has been announced but is not in production. Samples may or may not be available.

OBSELETE: TI has discontinued the production of the device.

(2) **RoHS:** TI defines "RoHS" to mean semiconductor products that are compliant with the current EU RoHS requirements for all 10 RoHS substances, including the requirement that RoHS substance do not exceed 0.1% by weight in homogeneous materials. Where designed to be soldered at high temperatures, "RoHS" products are suitable for use in specified lead-free processes. TI may reference these types of products as "Pb-Free".

RoHS Exempt: TI defines "RoHS Exempt" to mean products that contain lead but are compliant with EU RoHS pursuant to a specific EU RoHS exemption.

Green: TI defines "Green" to mean the content of Chlorine (Cl) and Bromine (Br) based flame retardants meet JS709B low halogen requirements of <=1000ppm threshold. Antimony trioxide based flame retardants must also meet the <=1000ppm threshold requirement.

(3) MSL, Peak Temp. - The Moisture Sensitivity Level rating according to the JEDEC industry standard classifications, and peak solder temperature.

(4) There may be additional marking, which relates to the logo, the lot trace code information, or the environmental category on the device.

(5) Multiple Device Markings will be inside parentheses. Only one Device Marking contained in parentheses and separated by a "-" will appear on a device. If a line is indented then it is a continuation of the previous line and the two combined represent the entire Device Marking for that device.

(6) Lead/Ball Finish - Orderable Devices may have multiple material finish options. Finish options are separated by a vertical ruled line. Lead/Ball Finish values may wrap to two lines if the finish value exceeds the maximum column width.

Important Information and Disclaimer:The information provided on this page represents TI's knowledge and belief as of the date that it is provided. TI bases its knowledge and belief on information provided by third parties, and makes no representation or warranty as to the accuracy of such information. Efforts are underway to better integrate information from third parties. TI has taken and continues to take reasonable steps to provide representative and accurate information but may not have conducted destructive testing or chemical analysis on incoming materials and chemicals. TI and TI suppliers consider certain information to be proprietary, and thus CAS numbers and other limited information may not be available for release.

In no event shall TI's liability arising out of such information exceed the total purchase price of the TI part(s) at issue in this document sold by TI to Customer on an annual basis.

TAPE AND REEL INFORMATION



QUADRANT ASSIGNMENTS FOR PIN 1 ORIENTATION IN TAPE



*All dimensions are nominal

Device	Package Type	Package Drawing	Pins	SPQ	Reel Diameter (mm)	Reel Width W1 (mm)	A0 (mm)	B0 (mm)	K0 (mm)	P1 (mm)	W (mm)	Pin1 Quadrant
TCA9509DGKR	VSSOP	DGK	8	2500	330.0	12.4	5.3	3.4	1.4	8.0	12.0	Q1
TCA9509MRVHR	X2QFN	RVH	8	5000	180.0	8.4	1.8	1.8	0.5	4.0	8.0	Q1
TCA9509RVHR	X2QFN	RVH	8	5000	180.0	8.4	1.8	1.8	0.5	4.0	8.0	Q3

TAPE AND REEL BOX DIMENSIONS

*All dimensions are nominal

Device	Package Type	Package Drawing	Pins	SPQ	Length (mm)	Width (mm)	Height (mm)
TCA9509DGKR	VSSOP	DGK	8	2500	364.0	364.0	27.0
TCA9509MRVHR	X2QFN	RVH	8	5000	183.0	183.0	20.0
TCA9509RVHR	X2QFN	RVH	8	5000	202.0	201.0	28.0

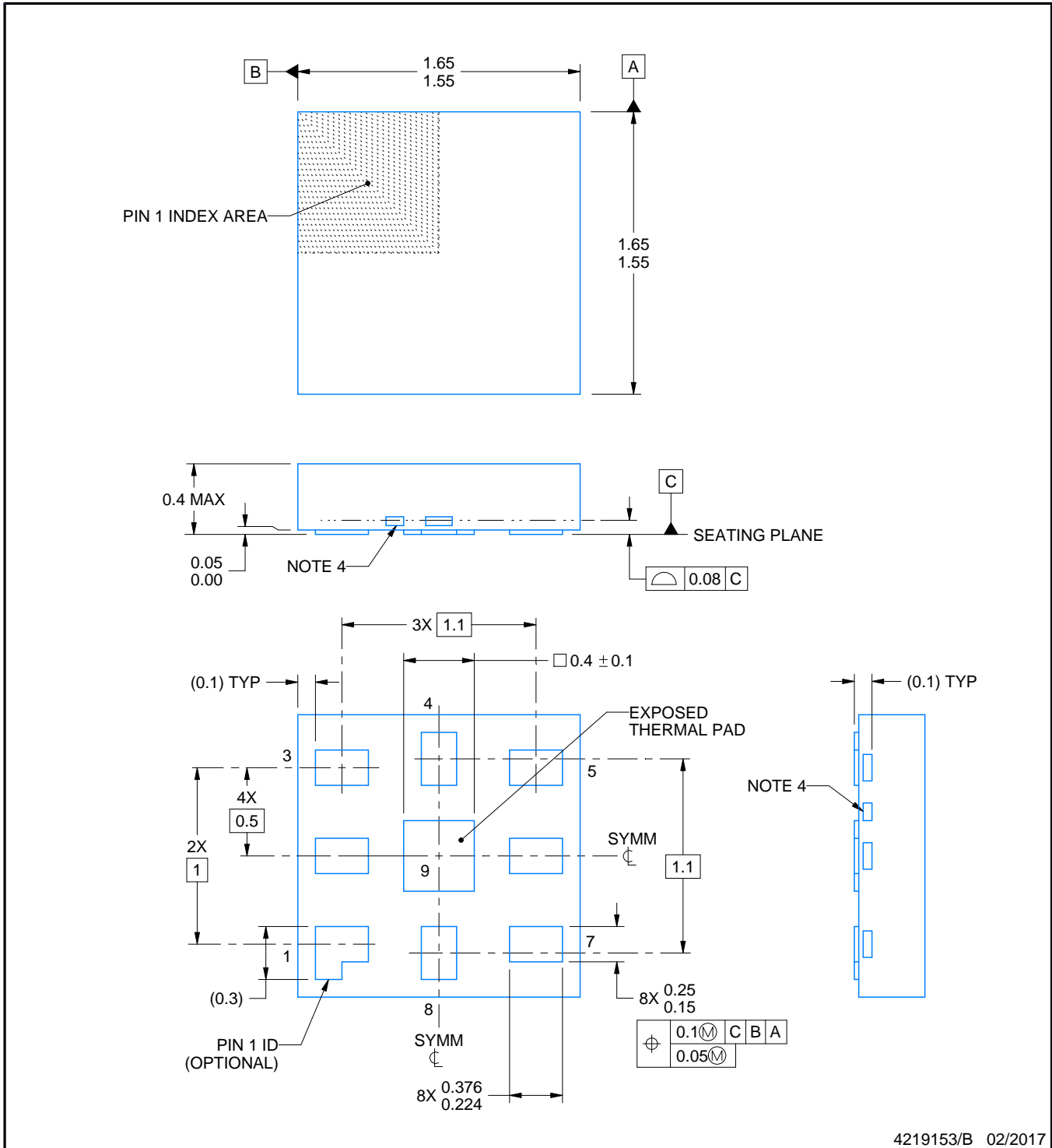
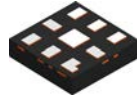

NOTES:

1. All linear dimensions are in millimeters. Any dimensions in parenthesis are for reference only. Dimensioning and tolerancing per ASME Y14.5M.
2. This drawing is subject to change without notice.
3. The package thermal pad must be soldered to the printed circuit board for thermal and mechanical performance.
4. Exposed tie bars may vary in size and location.

EXAMPLE BOARD LAYOUT

RVH0008A

X2QFN - 0.4 mm max height

PLASTIC QUAD FLATPACK - NO LEAD

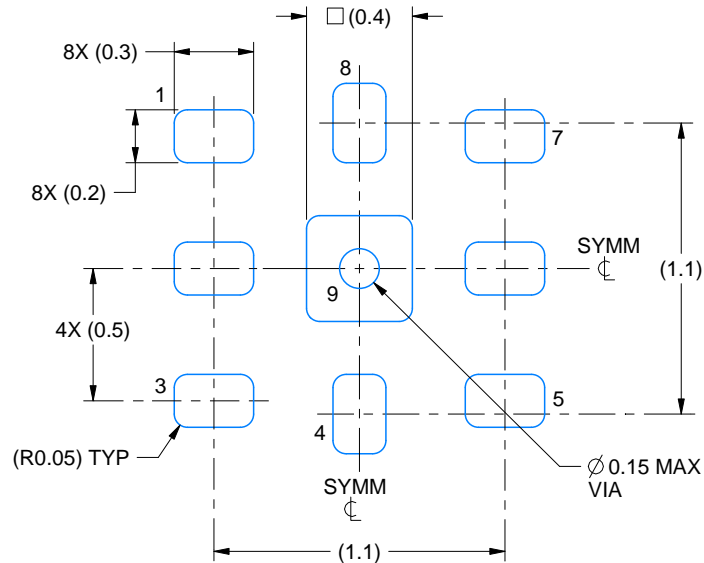

LAND PATTERN EXAMPLE
EXPOSED METAL SHOWN
SCALE:35X

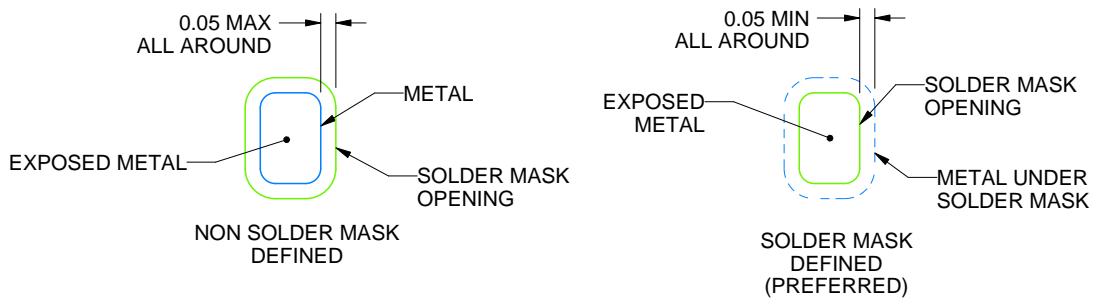

SOLDER MASK DETAILS

4219153/B 02/2017

NOTES: (continued)

5. This package is designed to be soldered to a thermal pad on the board. For more information, see Texas Instruments literature number SLUA271 (www.ti.com/lit/sluea271).
6. Vias are optional depending on application, refer to device data sheet. If any vias are implemented, refer to their locations shown on this view. It is recommended that vias under paste be filled, plugged or tented.

EXAMPLE STENCIL DESIGN

RVH0008A

X2QFN - 0.4 mm max height

PLASTIC QUAD FLATPACK - NO LEAD

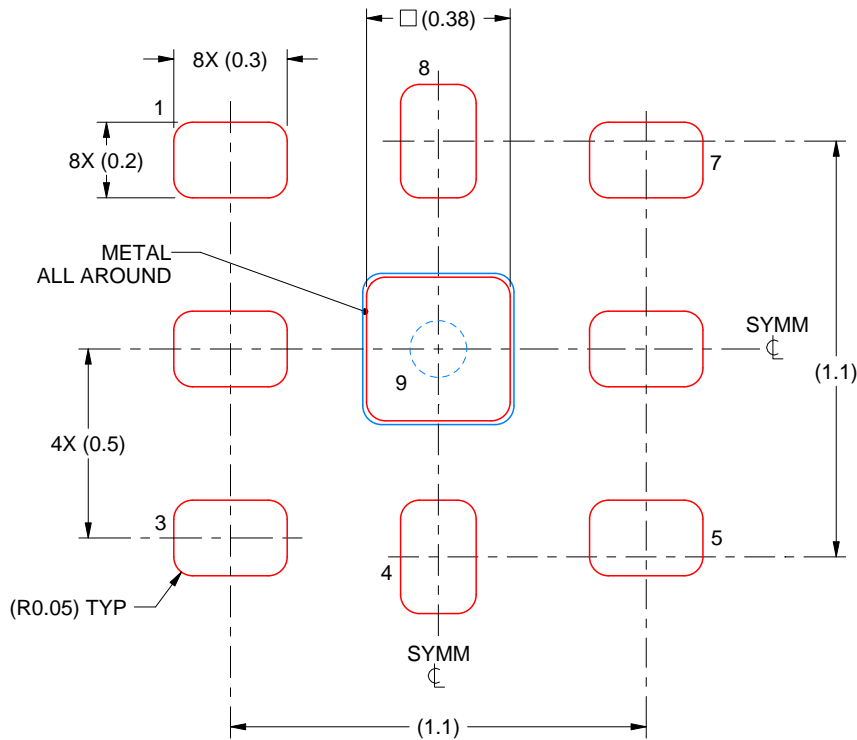

SOLDER PASTE EXAMPLE
BASED ON 0.1 mm THICK STENCIL

EXPOSED PAD 9
90% PRINTED SOLDER COVERAGE BY AREA UNDER PACKAGE
SCALE:50X

4219153/B 02/2017

NOTES: (continued)

7. Laser cutting apertures with trapezoidal walls and rounded corners may offer better paste release. IPC-7525 may have alternate design recommendations.

DGK (S-PDSO-G8)

PLASTIC SMALL-OUTLINE PACKAGE



- NOTES:
- A. All linear dimensions are in millimeters.
 - B. This drawing is subject to change without notice.
 - C. Body length does not include mold flash, protrusions, or gate burrs. Mold flash, protrusions, or gate burrs shall not exceed 0.15 per end.
 - D. Body width does not include interlead flash. Interlead flash shall not exceed 0.50 per side.
 - E. Falls within JEDEC MO-187 variation AA, except interlead flash.

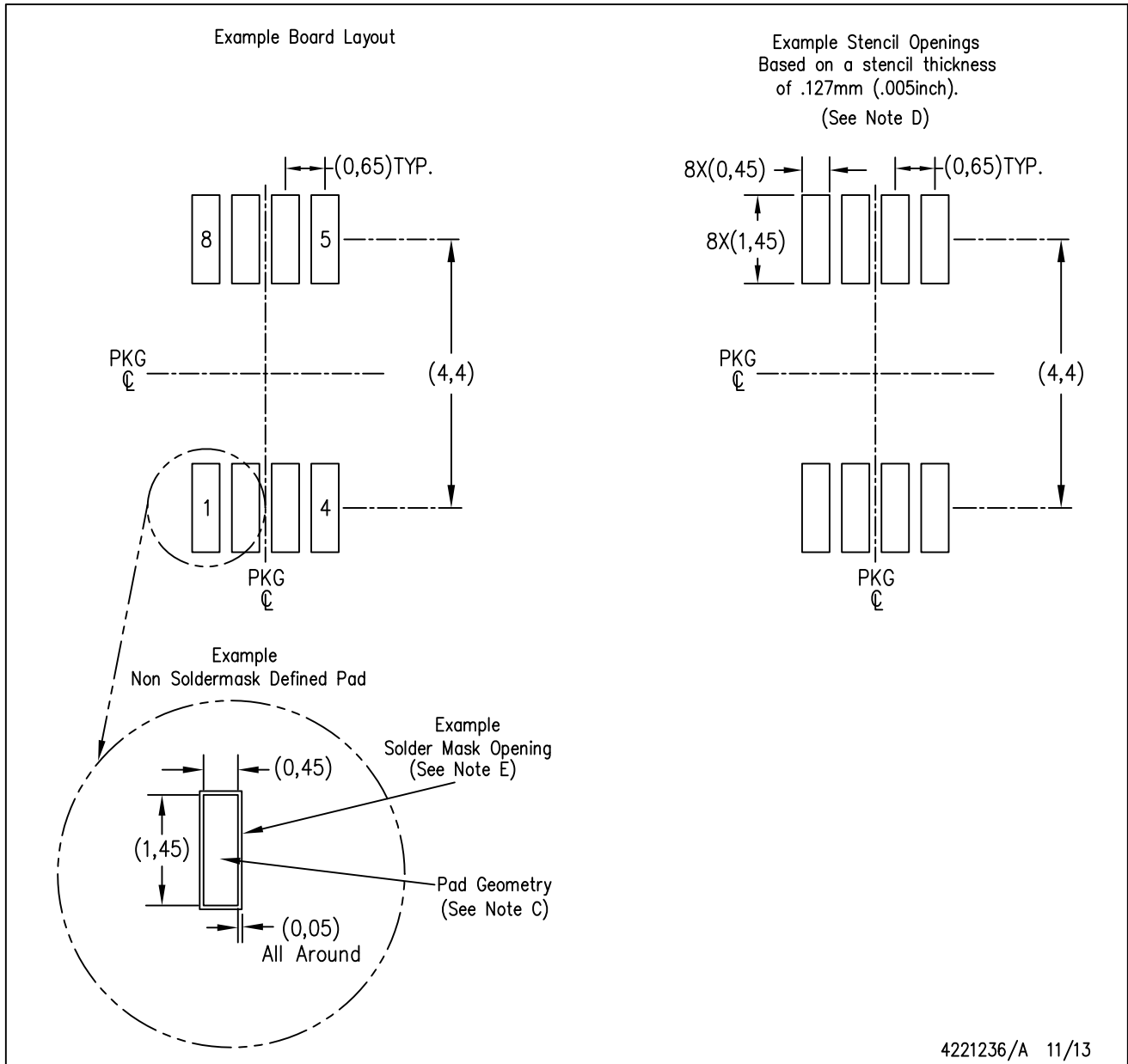

- NOTES:
- A. All linear dimensions are in millimeters.
 - B. This drawing is subject to change without notice.
 - C. Publication IPC-7351 is recommended for alternate designs.
 - D. Laser cutting apertures with trapezoidal walls and also rounding corners will offer better paste release. Customers should contact their board assembly site for stencil design recommendations. Refer to IPC-7525 for other stencil recommendations.
 - E. Customers should contact their board fabrication site for solder mask tolerances between and around signal pads.

IMPORTANT NOTICE AND DISCLAIMER

TI PROVIDES TECHNICAL AND RELIABILITY DATA (INCLUDING DATASHEETS), DESIGN RESOURCES (INCLUDING REFERENCE DESIGNS), APPLICATION OR OTHER DESIGN ADVICE, WEB TOOLS, SAFETY INFORMATION, AND OTHER RESOURCES "AS IS" AND WITH ALL FAULTS, AND DISCLAIMS ALL WARRANTIES, EXPRESS AND IMPLIED, INCLUDING WITHOUT LIMITATION ANY IMPLIED WARRANTIES OF MERCHANTABILITY, FITNESS FOR A PARTICULAR PURPOSE OR NON-INFRINGEMENT OF THIRD PARTY INTELLECTUAL PROPERTY RIGHTS.

These resources are intended for skilled developers designing with TI products. You are solely responsible for (1) selecting the appropriate TI products for your application, (2) designing, validating and testing your application, and (3) ensuring your application meets applicable standards, and any other safety, security, or other requirements. These resources are subject to change without notice. TI grants you permission to use these resources only for development of an application that uses the TI products described in the resource. Other reproduction and display of these resources is prohibited. No license is granted to any other TI intellectual property right or to any third party intellectual property right. TI disclaims responsibility for, and you will fully indemnify TI and its representatives against, any claims, damages, costs, losses, and liabilities arising out of your use of these resources.

TI's products are provided subject to TI's Terms of Sale (www.ti.com/legal/termsofsale.html) or other applicable terms available either on ti.com or provided in conjunction with such TI products. TI's provision of these resources does not expand or otherwise alter TI's applicable warranties or warranty disclaimers for TI products.

Mailing Address: Texas Instruments, Post Office Box 655303, Dallas, Texas 75265
Copyright © 2019, Texas Instruments Incorporated