

# LOW-VOLTAGE 24-BIT I<sup>2</sup>C AND SMBus I/O EXPANDER WITH INTERRUPT OUTPUT, RESET, AND CONFIGURATION REGISTERS

Check for Samples: [TCA6424A](#)

## FEATURES

- Operating Power-Supply Voltage Range of 1.65 V to 5.5 V
- Allows Bidirectional Voltage-Level Translation and GPIO Expansion Between:
  - 1.8-V SCL/SDA and 1.8-V, 2.5-V, 3.3-V, or 5-V P Port
  - 2.5-V SCL/SDA and 1.8-V, 2.5-V, 3.3-V, or 5-V P Port
  - 3.3-V SCL/SDA and 1.8-V, 2.5-V, 3.3-V, or 5-V P Port
  - 5-V SCL/SDA and 1.8-V, 2.5-V, 3.3-V, or 5-V P Port
- I<sup>2</sup>C to Parallel Port Expander
- Low Standby Current Consumption of 1  $\mu$ A
- Schmitt-Trigger Action Allows Slow Input Transition and Better Switching Noise Immunity at the SCL and SDA Inputs
  - $V_{hys} = 0.18$  V Typ at 1.8 V
  - $V_{hys} = 0.25$  V Typ at 2.5 V
  - $V_{hys} = 0.33$  V Typ at 3.3 V
  - $V_{hys} = 0.5$  V Typ at 5 V
- 5-V Tolerant I/O Ports
- Active-Low Reset Input ( $\overline{\text{RESET}}$ )
- Open-Drain Active-Low Interrupt Output ( $\overline{\text{INT}}$ )
- 400-kHz Fast I<sup>2</sup>C Bus
- Input/Output Configuration Register
- Polarity Inversion Register
- Internal Power-On Reset
- Power Up With All Channels Configured as Inputs
- No Glitch On Power Up
- Noise Filter on SCL/SDA Inputs
- Latched Outputs With High-Current Drive Maximum Capability for Directly Driving LEDs
- Latch-Up Performance Exceeds 100 mA Per JESD 78, Class II
- ESD Protection Exceeds JESD 22
  - 2000-V Human-Body Model (A114-A)
  - 200-V Machine Model (A115-A)
  - 1000-V Charged-Device Model (C101)

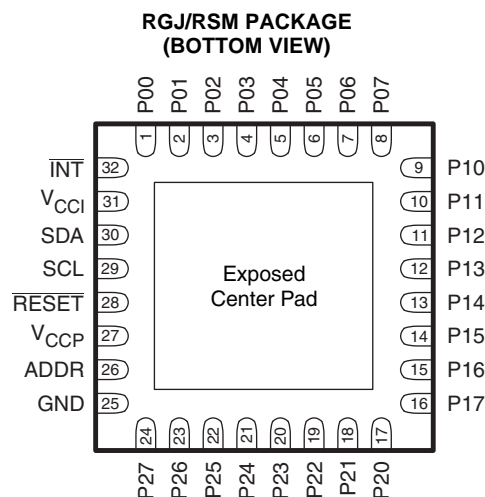

If used, the exposed center pad must be connected as a secondary ground or left electrically open.

## DESCRIPTION/ORDERING INFORMATION

This 24-bit I/O expander for the two-line bidirectional bus (I<sup>2</sup>C) is designed to provide general-purpose remote I/O expansion for most microcontroller families via the I<sup>2</sup>C interface [serial clock (SCL) and serial data (SDA)].

The major benefit of this device is its wide  $V_{CC}$  range. It can operate from 1.65 V to 5.5 V on the P-port side and on the SDA/SCL side. This allows the TCA6424A to interface with next-generation microprocessors and microcontrollers on the SDA/SCL side, where supply levels are dropping down to conserve power. In contrast to the dropping power supplies of microprocessors and microcontrollers, some PCB components, such as LEDs, remain at a 5-V power supply.



Please be aware that an important notice concerning availability, standard warranty, and use in critical applications of Texas Instruments semiconductor products and disclaimers thereto appears at the end of this data sheet.

## DESCRIPTION/ORDERING INFORMATION (CONTINUED)

The bidirectional voltage level translation in the TCA6424A is provided through  $V_{CCI}$ .  $V_{CCI}$  should be connected to the  $V_{CC}$  of the external SCL/SDA lines. This indicates the  $V_{CC}$  level of the I<sup>2</sup>C bus to the TCA6424A. The voltage level on the P-port of the TCA6424A is determined by the  $V_{CCP}$ .

The TCA6424A consists of three 8-bit Configuration (input or output selection), Input, Output, and Polarity Inversion (active high) registers. At power on, the I/Os are configured as inputs. However, the system master can enable the I/Os as either inputs or outputs by writing to the I/O configuration bits. The data for each input or output is kept in the corresponding input or output register. The polarity of the Input Port register can be inverted with the Polarity Inversion register. All registers can be read by the system master.

The system master can reset the TCA6424A in the event of a timeout or other improper operation by asserting a low in the RESET input. The power-on reset puts the registers in their default state and initializes the I<sup>2</sup>C/SMBus state machine. The RESET pin causes the same reset/initialization to occur without depowering the part.

The TCA6424A open-drain interrupt ( $\overline{INT}$ ) output is activated when any input state differs from its corresponding Input Port register state and is used to indicate to the system master that an input state has changed.

$\overline{INT}$  can be connected to the interrupt input of a microcontroller. By sending an interrupt signal on this line, the remote I/O can inform the microcontroller if there is incoming data on its ports without having to communicate via the I<sup>2</sup>C bus. Thus, the TCA6424A can remain a simple slave device.

The device P-port outputs have high-current sink capabilities for directly driving LEDs while consuming low device current.

One hardware pin (ADDR) can be used to program and vary the fixed I<sup>2</sup>C address and allow up to two devices to share the same I<sup>2</sup>C bus or SMBus.

### ORDERING INFORMATION

$T_A$	PACKAGE <sup>(1) (2)</sup>		ORDERABLE PART NUMBER	TOP-SIDE MARKING
-40°C to 85°C	QFN – RGJ	Reel of 3000	TCA6424ARGJR	PH424
	QFN – RSM	TBD	TCA6424ARSMR	TBD

(1) Package drawings, thermal data, and symbolization are available at [www.ti.com/packaging](http://www.ti.com/packaging).

(2) For the most current package and ordering information, see the Package Option Addendum at the end of this document, or see the TI website at [www.ti.com](http://www.ti.com).

**Table 1. TERMINAL FUNCTIONS**

TERMINAL		DESCRIPTION
PIN NO.	NAME	
1	P00	P-port input/output (push-pull design structure). At power on, P00 is configured as an input.
2	P01	P-port input/output (push-pull design structure). At power on, P01 is configured as an input.
3	P02	P-port input/output (push-pull design structure). At power on, P02 is configured as an input.
4	P03	P-port input/output (push-pull design structure). At power on, P03 is configured as an input.
5	P04	P-port input/output (push-pull design structure). At power on, P04 is configured as an input.
6	P05	P-port input/output (push-pull design structure). At power on, P05 is configured as an input.
7	P06	P-port input/output (push-pull design structure). At power on, P06 is configured as an input.
8	P07	P-port input/output (push-pull design structure). At power on, P07 is configured as an input.
9	P10	P-port input/output (push-pull design structure). At power on, P10 is configured as an input.
10	P11	P-port input/output (push-pull design structure). At power on, P11 is configured as an input.
11	P12	P-port input/output (push-pull design structure). At power on, P12 is configured as an input.
12	P13	P-port input/output (push-pull design structure). At power on, P13 is configured as an input.
13	P14	P-port input/output (push-pull design structure). At power on, P14 is configured as an input.
14	P15	P-port input/output (push-pull design structure). At power on, P15 is configured as an input.
15	P16	P-port input/output (push-pull design structure). At power on, P16 is configured as an input.
16	P17	P-port input/output (push-pull design structure). At power on, P17 is configured as an input.
17	P20	P-port input/output (push-pull design structure). At power on, P20 is configured as an input.
18	P21	P-port input/output (push-pull design structure). At power on, P21 is configured as an input.
19	P22	P-port input/output (push-pull design structure). At power on, P22 is configured as an input.
20	P23	P-port input/output (push-pull design structure). At power on, P23 is configured as an input.
21	P24	P-port input/output (push-pull design structure). At power on, P24 is configured as an input.
22	P25	P-port input/output (push-pull design structure). At power on, P25 is configured as an input.
23	P26	P-port input/output (push-pull design structure). At power on, P26 is configured as an input.
24	P27	P-port input/output (push-pull design structure). At power on, P27 is configured as an input.
25	GND	Ground
26	ADDR	Address input. Connect directly to $V_{CCP}$ or ground.
27	$V_{CCP}$	Supply voltage of TCA6424A for P port
28	$\overline{\text{RESET}}$	Active-low reset input. Connect to $V_{CCI}$ through a pullup resistor, if no active connection is used.
29	SCL	Serial clock bus. Connect to $V_{CCI}$ through a pullup resistor.
30	SDA	Serial data bus. Connect to $V_{CCI}$ through a pullup resistor.
31	$V_{CCI}$	Supply voltage of I <sup>2</sup> C bus. Connect directly to the $V_{CC}$ of the external I <sup>2</sup> C master. Provides voltage-level translation.
32	$\overline{\text{INT}}$	Interrupt output. Connect to $V_{CCI}$ through a pullup resistor.

## Voltage Translation

Table 2 shows how to set up  $V_{CC}$  levels for the necessary voltage translation between the I<sup>2</sup>C bus and the TCA6424A.

**Table 2. Voltage Translation**

V <sub>CCI</sub> (SDA AND SCL OF I <sup>2</sup> C MASTER) (V)	V <sub>CCP</sub> (P PORT) (V)
1.8	1.8
1.8	2.5
1.8	3.3
1.8	5
2.5	1.8
2.5	2.5
2.5	3.3
2.5	5
3.3	1.8
3.3	2.5
3.3	3.3
3.3	5
5	1.8
5	2.5
5	3.3
5	5

**LOGIC DIAGRAM (POSITIVE LOGIC)**

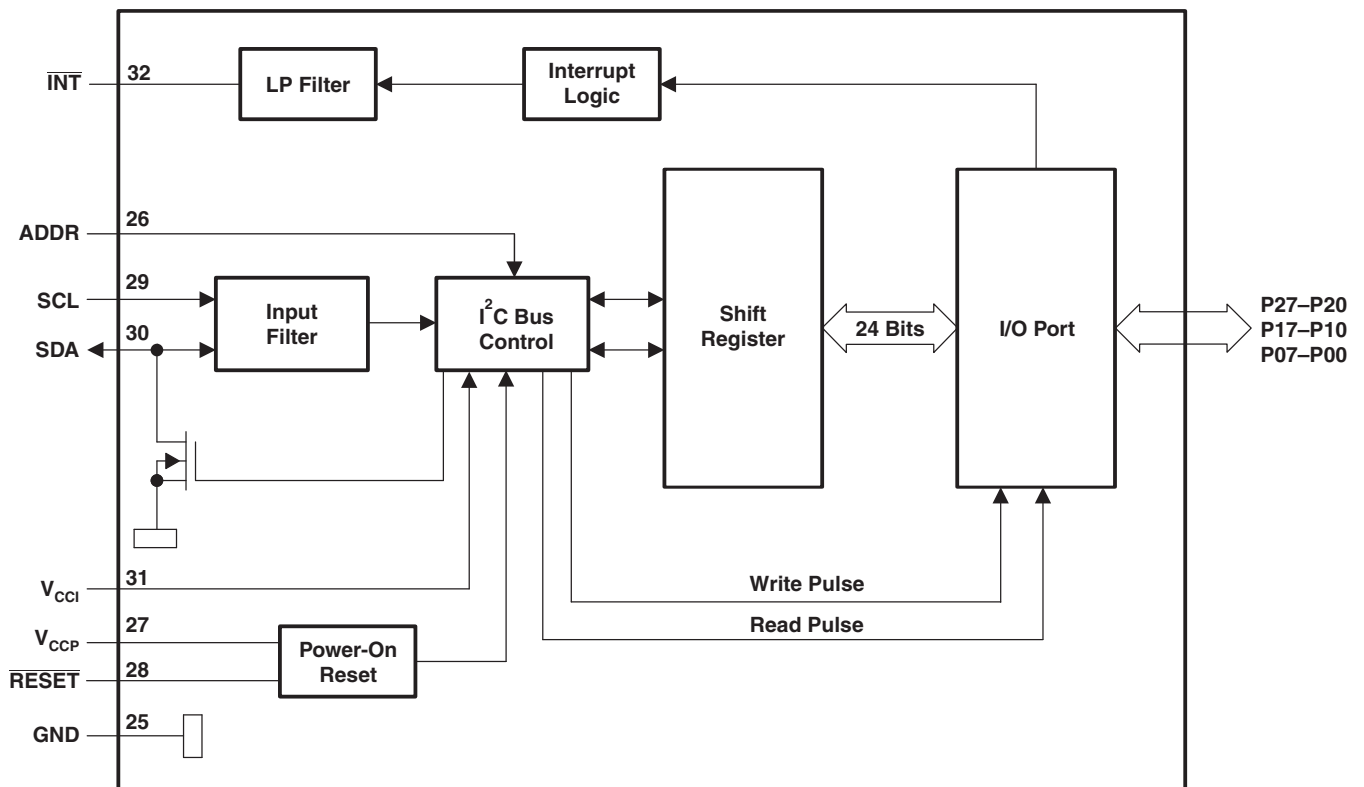

- A. All I/Os are set to inputs at reset.
- B. Pin numbers shown are for the RGJ package.

Simplified Schematic of P00 to P27

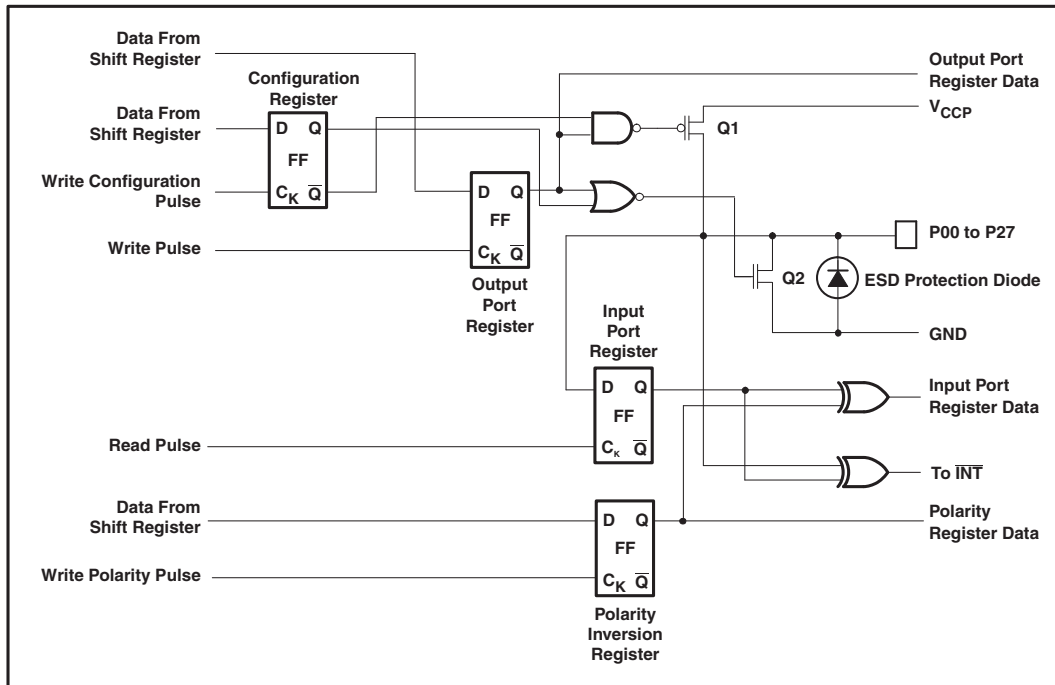

- A. On power up or reset, all registers return to default values.

## I/O Port

When an I/O is configured as an input, FETs Q1 and Q2 are off, which creates a high-impedance input. The input voltage may be raised above  $V_{CC}$  to a maximum of 5.5 V.

If the I/O is configured as an output, Q1 or Q2 is enabled, depending on the state of the output port register. In this case, there are low-impedance paths between the I/O pin and either  $V_{CC}$  or GND. The external voltage applied to this I/O pin should not exceed the recommended levels for proper operation.

## I<sup>2</sup>C Interface

The bidirectional I<sup>2</sup>C bus consists of the serial clock (SCL) and serial data (SDA) lines. Both lines must be connected to a positive supply through a pullup resistor when connected to the output stages of a device. Data transfer may be initiated only when the bus is not busy.

I<sup>2</sup>C communication with this device is initiated by a master sending a Start condition, a high-to-low transition on the SDA input/output, while the SCL input is high (see [Figure 1](#)). After the Start condition, the device address byte is sent, most significant bit (MSB) first, including the data direction bit ( $R/\overline{W}$ ).

After receiving the valid address byte, this device responds with an acknowledge (ACK), a low on the SDA input/output during the high of the ACK-related clock pulse. The address (ADDR) input of the slave device must not be changed between the Start and the Stop conditions.

On the I<sup>2</sup>C bus, only one data bit is transferred during each clock pulse. The data on the SDA line must remain stable during the high pulse of the clock period, as changes in the data line at this time are interpreted as control commands (Start or Stop) (see [Figure 2](#)).

A Stop condition, a low-to-high transition on the SDA input/output while the SCL input is high, is sent by the master (see [Figure 1](#)).

Any number of data bytes can be transferred from the transmitter to receiver between the Start and the Stop conditions. Each byte of eight bits is followed by one ACK bit. The transmitter must release the SDA line before the receiver can send an ACK bit. The device that acknowledges must pull down the SDA line during the ACK clock pulse, so that the SDA line is stable low during the high pulse of the ACK-related clock period (see [Figure 3](#)). When a slave receiver is addressed, it must generate an ACK after each byte is received. Similarly, the master must generate an ACK after each byte that it receives from the slave transmitter. Setup and hold times must be met to ensure proper operation.

A master receiver signals an end of data to the slave transmitter by not generating an acknowledge (NACK) after the last byte has been clocked out of the slave. This is done by the master receiver by holding the SDA line high. In this event, the transmitter must release the data line to enable the master to generate a Stop condition.

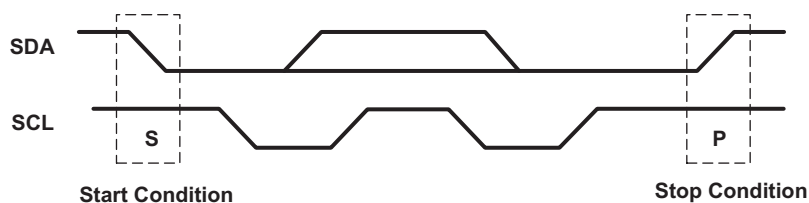

**Figure 1. Definition of Start and Stop Conditions**

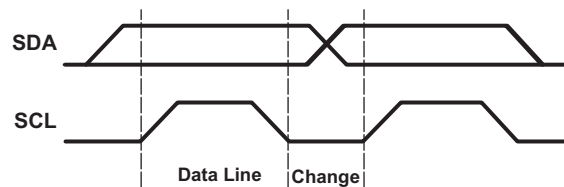

**Figure 2. Bit Transfer**

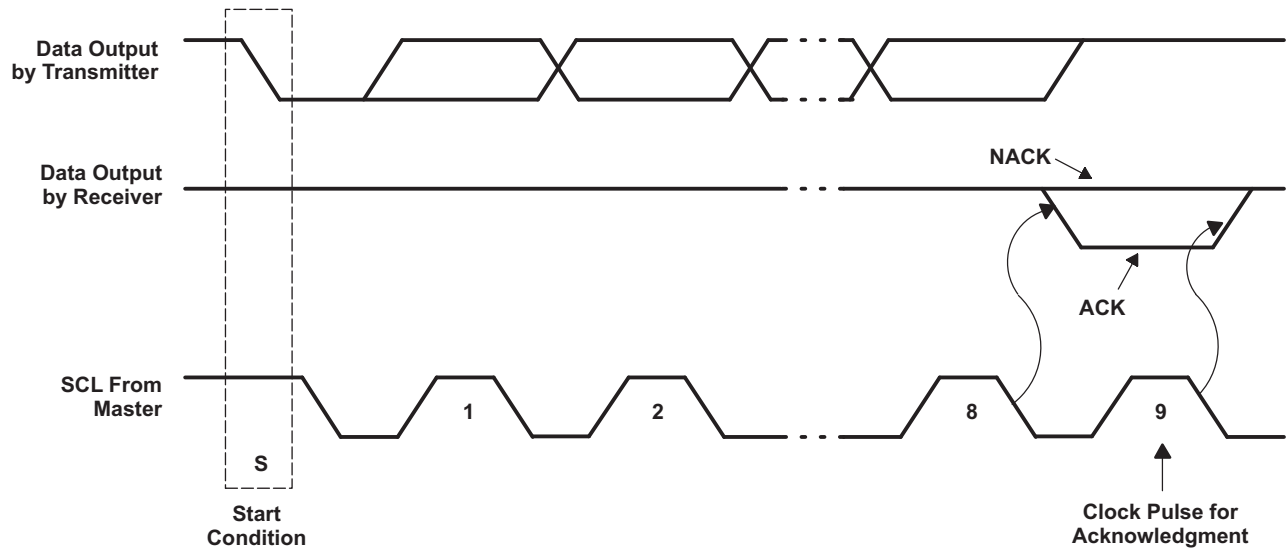

Figure 3. Acknowledgment on the I<sup>2</sup>C Bus

Table 3. Interface Definition

BYTE	BIT							
	7 (MSB)	6	5	4	3	2	1	0 (LSB)
I <sup>2</sup> C slave address	L	H	L	L	L	H	ADDR	R/W
I/O data bus	P07	P06	P05	P04	P03	P02	P01	P00
	P17	P16	P15	P14	P13	P12	P11	P10
	P27	P26	P25	P24	P23	P22	P21	P20

### Device Address

The address of the TCA6424A is shown in Figure 4.

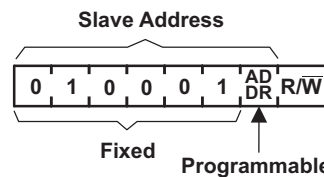

Figure 4. TCA6424A Address

Table 4. Address Reference

ADDR	I <sup>2</sup> C BUS SLAVE ADDRESS
L	34 (decimal), 22 (hexadecimal)
H	35 (decimal), 23 (hexadecimal)

The last bit of the slave address defines the operation (read or write) to be performed. A high (1) selects a read operation, while a low (0) selects a write operation.

### Control Register and Command Byte

Following the successful acknowledgment of the address byte, the bus master sends a command byte, which is stored in the control register in the TCA6424A. Four bits of this data byte state the operation (read or write) and the internal registers (input, output, polarity inversion, or configuration) that will be affected. The control register can be written or read through the I<sup>2</sup>C bus. The command byte is sent only during a write transmission.

The control register includes an Auto-Increment (AI) bit which is the most significant bit (bit 7) of the command byte. At power-up, the control register defaults to 00 (hex), with the AI bit set to logic 1, and the lowest 7 bits set to logic 0.

If AI is 1, the 2 least significant bits are automatically incremented after a read or write. This allows the user to program and/or read the 3 register banks sequentially. If more than 3 bytes of data are written when AI is 1, previous data in the selected registers will be overwritten. Reserved registers are skipped and not accessed (refer to Table 5).

If AI is 0, the 2 least significant bits are not incremented after data is read or written. During a read operation, the same register bank is read each time. During a write operation, data is written to the same register bank each time.

Reserved command codes and command byte outside the range stated in the Command Byte table must not be accessed for proper device functionality.

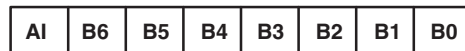

**Figure 5. Control Register Bits**



**Table 5. Command Byte**

CONTROL REGISTER BITS								AUTO-INCREMENT STATE	COMMAND BYTE (HEX)	REGISTER	PROTOCOL	POWER-UP DEFAULT
AI	B6	B5	B4	B3	B2	B1	B0					
0	0	0	0	0	0	0	0	Disable	00	Input Port 0	Read byte	xxxx xxxx <sup>(1)</sup>
1	0	0	0	0	0	0	0	Enable	80			
0	0	0	0	0	0	0	1	Disable	01	Input Port 1	Read byte	xxxx xxxx <sup>(1)</sup>
1	0	0	0	0	0	0	1	Enable	81			
0	0	0	0	0	0	1	0	Disable	02	Input Port 2	Read byte	xxxx xxxx <sup>(1)</sup>
1	0	0	0	0	0	1	0	Enable	82			
0	0	0	0	0	0	1	1	Disable	03	Reserved	Reserved	Reserved
1	0	0	0	0	0	1	1	Enable	83			
0	0	0	0	0	1	0	0	Disable	04	Output Port 0	Read/write byte	1111 1111
1	0	0	0	0	1	0	0	Enable	84			
0	0	0	0	0	1	0	1	Disable	05	Output Port 1	Read/write byte	1111 1111
1	0	0	0	0	1	0	1	Enable	85			
0	0	0	0	0	1	1	0	Disable	06	Output Port 2	Read/write byte	1111 1111
1	0	0	0	0	1	1	0	Enable	86			
0	0	0	0	0	1	1	1	Disable	07	Reserved	Reserved	Reserved
1	0	0	0	0	1	1	1	Enable	87			
0	0	0	0	1	0	0	0	Disable	08	Polarity Inversion Port 0	Read/write byte	0000 0000
1	0	0	0	1	0	0	0	Enable	88			
0	0	0	0	1	0	0	1	Disable	09	Polarity Inversion Port 1	Read/write byte	0000 0000
1	0	0	0	1	0	0	1	Enable	89			
0	0	0	0	1	0	1	0	Disable	0A	Polarity Inversion Port 2	Read/write byte	0000 0000
1	0	0	0	1	0	1	0	Enable	8A			
0	0	0	0	1	0	1	1	Disable	0B	Reserved	Reserved	Reserved
1	0	0	0	1	0	1	1	Enable	8B			
0	0	0	0	1	1	0	0	Disable	0C	Configuration Port 0	Read/write byte	1111 1111
1	0	0	0	1	1	0	0	Enable	8C			
0	0	0	0	1	1	0	1	Disable	0D	Configuration Port 1	Read/write byte	1111 1111
1	0	0	0	1	1	0	1	Enable	8D			
0	0	0	0	1	1	1	0	Disable	0E	Configuration Port 2	Read/write byte	1111 1111
1	0	0	0	1	1	1	0	Enable	8E			
0	0	0	0	1	1	1	1	Disable	0F	Reserved	Reserved	Reserved
1	0	0	0	1	1	1	1	Enable	8F			

(1) Undefined

## Register Descriptions

The Input Port registers (registers 0, 1 and 2) reflect the incoming logic levels of the pins, regardless of whether the pin is defined as an input or an output by the Configuration register. They act only on read operation. Writes to these registers have no effect. The default value (X) is determined by the externally applied logic level. Before a read operation, a write transmission is sent with the command byte to indicate to the I<sup>2</sup>C device that the Input Port register will be accessed next.

**Table 6. Registers 0 and 1 (Input Port Registers)**

<b>BIT</b>	I-07	I-06	I-05	I-04	I-03	I-02	I-01	I-00
<b>DEFAULT</b>	X	X	X	X	X	X	X	X
<b>BIT</b>	I-17	I-16	I-15	I-14	I-13	I-12	I-11	I-10
<b>DEFAULT</b>	X	X	X	X	X	X	X	X
<b>BIT</b>	I-27	I-26	I-25	I-24	I-23	I-22	I-21	I-20
<b>DEFAULT</b>	X	X	X	X	X	X	X	X

The Output Port registers (registers 4, 5 and 6) shows the outgoing logic levels of the pins defined as outputs by the Configuration register. Bit values in these registers have no effect on pins defined as inputs. In turn, reads from these registers reflect the value that is in the flip-flop controlling the output selection, NOT the actual pin value.

**Table 7. Registers 2 and 3 (Output Port Registers)**

<b>BIT</b>	O-07	O-06	O-05	O-04	O-03	O-02	O-01	O-00
<b>DEFAULT</b>	1	1	1	1	1	1	1	1
<b>BIT</b>	O-17	O-16	O-15	O-14	O-13	O-12	O-11	O-10
<b>DEFAULT</b>	1	1	1	1	1	1	1	1
<b>BIT</b>	O-27	O-26	O-25	O-24	O-23	O-22	O-21	O-20
<b>DEFAULT</b>	1	1	1	1	1	1	1	1

The Polarity Inversion registers (registers 8, 9 and 10) allow polarity inversion of pins defined as inputs by the Configuration register. If a bit in these registers is set (written with 1), the corresponding port pin's polarity is inverted. If a bit in these registers is cleared (written with a 0), the corresponding port pin's original polarity is retained.

**Table 8. Registers 4 and 5 (Polarity Inversion Registers)**

<b>BIT</b>	P-07	P-06	P-05	P-04	P-03	P-02	P-01	P-00
<b>DEFAULT</b>	0	0	0	0	0	0	0	0
<b>BIT</b>	P-17	P-16	P-15	P-14	P-13	P-12	P-11	P-10
<b>DEFAULT</b>	0	0	0	0	0	0	0	0
<b>BIT</b>	P-27	P-26	P-25	P-24	P-23	P-22	P-21	P-20
<b>DEFAULT</b>	0	0	0	0	0	0	0	0

The Configuration registers (registers 12, 13 and 14) configure the direction of the I/O pins. If a bit in these registers is set to 1, the corresponding port pin is enabled as an input with a high-impedance output driver. If a bit in these registers is cleared to 0, the corresponding port pin is enabled as an output.

**Table 9. Registers 6 and 7 (Configuration Registers)**

<b>BIT</b>	C-07	C-06	C-05	C-04	C-03	C-02	C-01	C-00
<b>DEFAULT</b>	1	1	1	1	1	1	1	1
<b>BIT</b>	C-17	C-16	C-15	C-14	C-13	C-12	C-11	C-10
<b>DEFAULT</b>	1	1	1	1	1	1	1	1
<b>BIT</b>	C-27	C-26	C-25	C-24	C-23	C-22	C-21	C-20
<b>DEFAULT</b>	1	1	1	1	1	1	1	1

## Power-On Reset

When power (from 0 V) is applied to  $V_{CCP}$ , an internal power-on reset holds the TCA6424A in a reset condition until  $V_{CCP}$  has reached  $V_{POR}$ . At that time, the reset condition is released, and the TCA6424A registers and I<sup>2</sup>C/SMBus state machine initializes to their default states. After that,  $V_{CCP}$  must be lowered to below 0.2 V and back up to the operating voltage for a power-reset cycle.

## ADD TABLE WITH SPECS AND DEFINITIONS TO SUPPORT POR OPERATION

### Reset Input ( $\overline{\text{RESET}}$ )

The  $\overline{\text{RESET}}$  input can be asserted to initialize the system while keeping the  $V_{CCP}$  at its operating level. A reset can be accomplished by holding the  $\overline{\text{RESET}}$  pin low for a minimum of  $t_W$ . The TCA6424A registers and I<sup>2</sup>C/SMBus state machine are changed to their default state once  $\overline{\text{RESET}}$  is low (0). When  $\overline{\text{RESET}}$  is high (1), the I/O levels at the P port can be changed externally or through the master. This input requires a pullup resistor to  $V_{CCI}$ , if no active connection is used.

### Interrupt Output ( $\overline{\text{INT}}$ )

An interrupt is generated by any rising or falling edge of the port inputs in the input mode. After time  $t_{IV}$ , the signal  $\overline{\text{INT}}$  is valid. Resetting the interrupt circuit is achieved when data on the port is changed to the original setting or when data is read from the port that generated the interrupt. Resetting occurs in the read mode at the acknowledge (ACK) or not acknowledge (NACK) bit after the rising edge of the SCL signal. Interrupts that occur during the ACK or NACK clock pulse can be lost (or be very short) due to the resetting of the interrupt during this pulse. Each change of the I/Os after resetting is detected and is transmitted as  $\overline{\text{INT}}$ .

Reading from or writing to another device does not affect the interrupt circuit, and a pin configured as an output cannot cause an interrupt. Changing an I/O from an output to an input may cause a false interrupt to occur, if the state of the pin does not match the contents of the Input Port register.

The  $\overline{\text{INT}}$  output has an open-drain structure and requires pullup resistor to  $V_{CCP}$  or  $V_{CCI}$  depending on the application. If the  $\overline{\text{INT}}$  signal is connected back to the processor that provides the SCL signal to the TCA6424A then the  $\overline{\text{INT}}$  pin has to be connected to  $V_{CCI}$ . If not, the  $\overline{\text{INT}}$  pin can be connected to  $V_{CCP}$ .

## Bus Transactions

Data is exchanged between the master and TCA6424A through write and read commands.

### Writes

Data is transmitted to the TCA6424A by sending the device address and setting the least-significant bit (LSB) to a logic 0 (see [Figure 4](#) for device address). The command byte is sent after the address and determines which register receives the data that follows the command byte. There is no limitation on the number of data bytes sent in one write transmission.

The twelve registers within the TCA6424A are grouped into four different sets. The four sets of registers are input ports, output ports, polarity inversion ports and configuration ports. After sending data to one register, the next data byte is sent to the next register in the group of 3 registers (see [Figure 6](#) and [Figure 7](#)). For example, if the first byte is sent to Output Port 2 (register 6), the next byte is stored in Output Port 0 (register 4).

There is no limitation on the number of data bytes sent in one write transmission. In this way, each 8-bit register may be updated independently of the other registers.

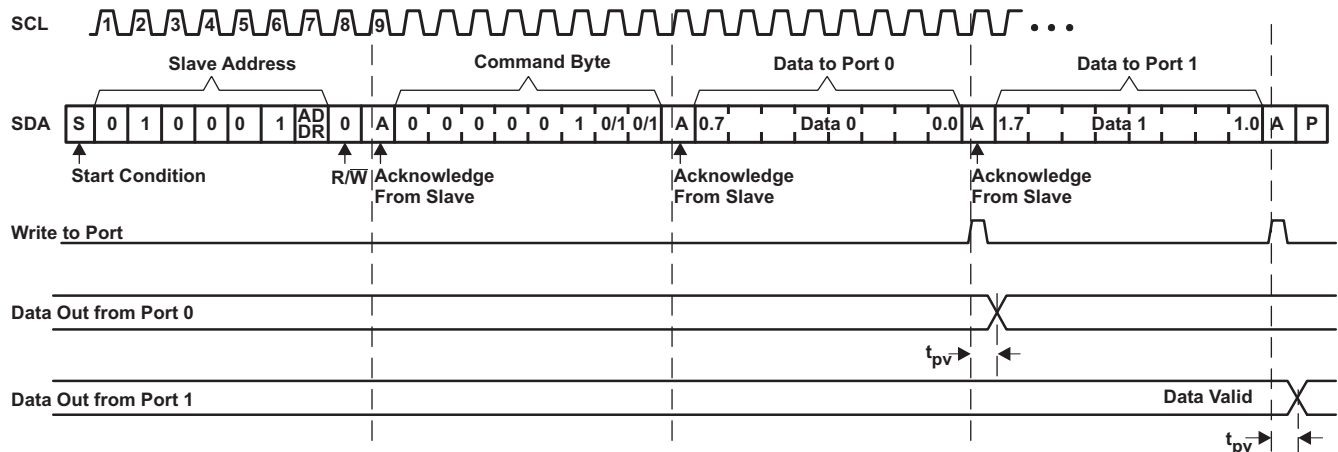

Figure 6. Write to Output Port Register

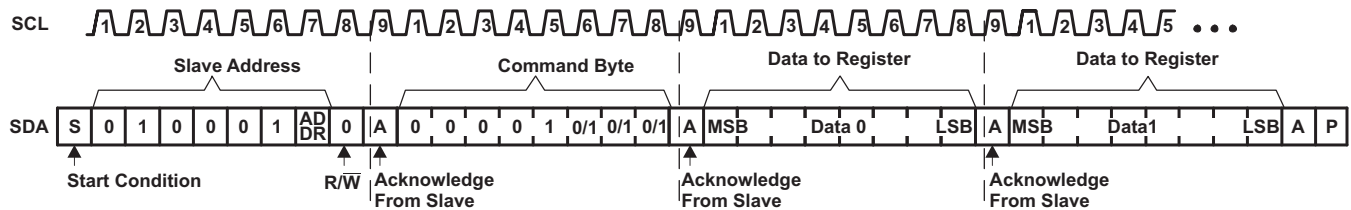

Figure 7. Write to Configuration or Polarity Inversion Registers

## Reads

The bus master first must send the TCA6424A address with the LSB set to a logic 0 (see Figure 4 for device address). The command byte is sent after the address and determines which register is accessed.

After a restart, the device address is sent again but, this time, the LSB is set to a logic 1. Data from the register defined by the command byte then is sent by the TCA6424A (see Figure 8 and Figure 9).

After a restart, the value of the register defined by the command byte matches the register being accessed when the restart occurred. For example, if the command byte references Input Port 1 before the restart, and the restart occurs when Input Port 0 is being read, the stored command byte changes to reference Input Port 0. The original command byte is forgotten. If a subsequent restart occurs, Input Port 0 is read first. Data is clocked into the register on the rising edge of the ACK clock pulse. After the first byte is read, additional bytes may be read, but the data now reflects the information in the other register in the pair. For example, if Input Port 1 is read, the next byte read is Input Port 0.

Data is clocked into the register on the rising edge of the ACK clock pulse. There is no limitation on the number of data bytes received in one read transmission, but when the final byte is received, the bus master must not acknowledge the data.

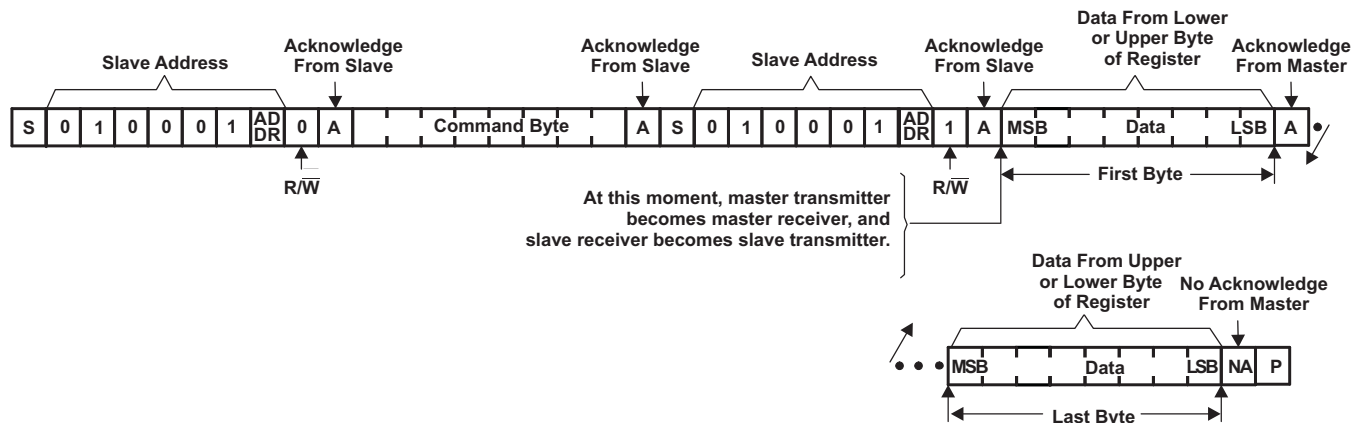
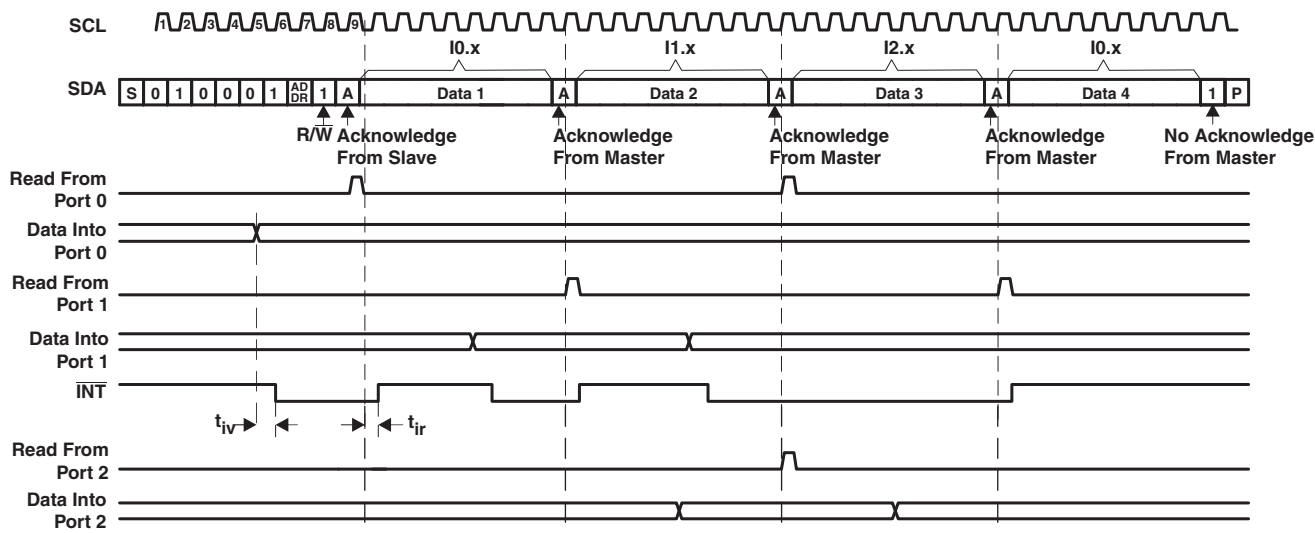

Figure 8. Read From Register



- A. Transfer of data can be stopped at any time by a Stop condition. When this occurs, data present at the latest acknowledge phase is valid (output mode). It is assumed that the command byte previously has been set to 00 (read Input Port register).
- B. This figure eliminates the command byte transfer, a restart, and slave address call between the initial slave address call and actual data transfer from P port (see Figure 8).
- C. Auto-increment mode is enabled.

Figure 9. Read Input Port Register

**ABSOLUTE MAXIMUM RATINGS<sup>(1)</sup>**

over operating free-air temperature range (unless otherwise noted)

				MIN	MAX	UNIT	
V <sub>CCI</sub>	Supply voltage range			-0.5	6.5	V	
V <sub>CCP</sub>	Supply voltage range			-0.5	6.5	V	
V <sub>I</sub>	Input voltage range <sup>(2)</sup>			-0.5	6.5	V	
V <sub>O</sub>	Output voltage range <sup>(2)</sup>			-0.5	6.5	V	
I <sub>IK</sub>	Input clamp current	ADDR, $\overline{\text{RESET}}$ , SCL	V <sub>I</sub> < 0		±20	mA	
I <sub>OK</sub>	Output clamp current	$\overline{\text{INT}}$	V <sub>O</sub> < 0		±20	mA	
I <sub>IOK</sub>	Input/output clamp current	P port	V <sub>O</sub> < 0 or V <sub>O</sub> > V <sub>CCP</sub>		±20	mA	
		SDA	V <sub>O</sub> < 0 or V <sub>O</sub> > V <sub>CCI</sub>		±20		
I <sub>OL</sub>	Continuous output low current	P port	V <sub>O</sub> = 0 to V <sub>CCP</sub>		25	mA	
		SDA, $\overline{\text{INT}}$	V <sub>O</sub> = 0 to V <sub>CCI</sub>		15		
I <sub>OH</sub>	Continuous output high current	P port	V <sub>O</sub> = 0 to V <sub>CCP</sub>		25	mA	
I <sub>CC</sub>	Continuous current through GND				200	mA	
	Continuous current through V <sub>CCP</sub>				160		
	Continuous current through V <sub>CCI</sub>				10		
θ <sub>JA</sub>	Package thermal impedance <sup>(3)</sup>		RGJ package		50.05	°C/W	
			RSM package		TBD		
T <sub>stg</sub>	Storage temperature range				-65	150	°C

- (1) Stresses beyond those listed under *Absolute Maximum Ratings* may cause permanent damage to the device. These are stress ratings only, and functional operation of the device at these or any other conditions beyond those indicated under *Recommended Operating Conditions* is not implied. Exposure to absolute-maximum-rated conditions for extended periods may affect device reliability.
- (2) The input negative-voltage and output voltage ratings may be exceeded if the input and output current ratings are observed.
- (3) The package thermal impedance is calculated in accordance with JESD 51-7.

**RECOMMENDED OPERATING CONDITIONS**

				MIN	MAX	UNIT	
V <sub>CCI</sub>	Supply voltage			1.65	5.5	V	
V <sub>CCP</sub>	Supply voltage			1.65	5.5	V	
V <sub>IH</sub>	High-level input voltage	SCL, SDA, $\overline{\text{RESET}}$		0.7 × V <sub>CCI</sub>	5.5	V	
		ADDR, P27–P00		0.7 × V <sub>CCP</sub>	5.5		
V <sub>IL</sub>	Low-level input voltage	SCL, SDA, $\overline{\text{RESET}}$		-0.5	0.3 × V <sub>CCI</sub>	V	
		ADDR, P27–P00		-0.5	0.3 × V <sub>CCP</sub>		
I <sub>OH</sub>	High-level output current	P27–P00			10	mA	
I <sub>OL</sub>	Low-level output current	P27–P00			25	mA	
T <sub>A</sub>	Operating free-air temperature				-40	85	°C

## ELECTRICAL CHARACTERISTICS

 over recommended operating free-air temperature range,  $V_{CCI} = 1.65\text{ V to }5.5\text{ V}$  (unless otherwise noted)

PARAMETER		TEST CONDITIONS	$V_{CCP}$	MIN	TYP <sup>(1)</sup>	MAX	UNIT	
$V_{IK}$	Input diode clamp voltage	$I_I = -18\text{ mA}$	1.65 V to 5.5 V	-1.2			V	
$V_{POR}$	Power-on reset voltage	$V_I = V_{CCP}$ or GND, $I_O = 0$	1.65 V to 5.5 V		1	1.4	V	
$V_{OH}$	P-port high-level output voltage	$I_{OH} = -8\text{ mA}$	1.65 V	1.2			V	
			2.3 V	1.8				
			3 V	2.6				
			4.5 V	4.1				
		$I_{OH} = -10\text{ mA}$	1.65 V	1				
			2.3 V	1.7				
			3 V	2.5				
			4.5 V	4.0				
$V_{OL}$	P-port low-level output voltage	$I_{OL} = 8\text{ mA}$	1.65 V			0.45	V	
			2.3 V			0.25		
			3 V			0.25		
			4.5 V			0.23		
		$I_{OL} = 10\text{ mA}$	1.65 V			0.6		
			2.3 V			0.3		
			3 V			0.25		
			4.5 V			0.24		
$I_{OL}$	SDA	$V_{OL} = 0.4\text{ V}$	1.65 V to 5.5 V	3			mA	
	$\overline{\text{INT}}$	$V_{OL} = 0.4\text{ V}$	1.65 V to 5.5 V	3	15			
$I_I$	SCL, SDA, $\overline{\text{RESET}}$	$V_I = V_{CCI}$ or GND	1.65 V to 5.5 V			$\pm 0.1$	$\mu\text{A}$	
	ADDR	$V_I = V_{CCP}$ or GND				$\pm 0.1$		
$I_{IH}$	P port	$V_I = V_{CCP}$	1.65 V to 5.5 V			1	$\mu\text{A}$	
$I_{IL}$	P port	$V_I = \text{GND}$				1	$\mu\text{A}$	
$I_{CC}$ ( $I_{CCP} + I_{CCI}$ )	Operating mode	SDA, P port, ADDR, $\overline{\text{RESET}}$	$V_I$ on SDA and $\overline{\text{RESET}} = V_{CCI}$ or GND, $V_I$ on P port and ADDR = $V_{CCP}$ , $I_O = 0$ , I/O = inputs, $f_{SCL} = 400\text{ kHz}$	1.65 V to 5.5 V		8	30	$\mu\text{A}$
		SDA, P port, ADDR, $\overline{\text{RESET}}$	$V_I$ on SDA and $\overline{\text{RESET}} = V_{CCI}$ or GND, $V_I$ on P port and ADDR = $V_{CCP}$ , $I_O = 0$ , I/O = inputs, $f_{SCL} = 100\text{ kHz}$	1.65 V to 5.5 V		1.7	10	
	Standby mode	SCL, SDA, P port, ADDR, $\overline{\text{RESET}}$	$V_I$ on SCL, SDA and $\overline{\text{RESET}} = V_{CCI}$ or GND, $V_I$ on P port and ADDR = $V_{CCP}$ , $I_O = 0$ , I/O = inputs, $f_{SCL} = 0$	1.65 V to 5.5 V		0.1	3	
$\Delta I_{CCI}$	Additional current in Standby mode	SCL, SDA, $\overline{\text{RESET}}$	1.65 V to 5.5 V			25	$\mu\text{A}$	
$\Delta I_{CCP}$		P port, ADDR,		One input at $V_{CCP} - 0.6\text{ V}$ , Other inputs at $V_{CCP}$ or GND				60
$C_I$	SCL	$V_I = V_{CCI}$ or GND	1.65 V to 5.5 V		6	7	pF	
$C_{IO}$	SDA	$V_{IO} = V_{CCI}$ or GND	1.65 V to 5.5 V		7	8	pF	
	P port	$V_{IO} = V_{CCP}$ or GND			7.5	8.5		

(1) Except for  $I_{CC}$ , all typical values are at nominal supply voltage ( $V_{CCP} = V_{CCI} = 1.8\text{-V, }2.5\text{-V, }3.3\text{-V, or }5\text{-V }V_{CC}$ ) and  $T_A = 25^\circ\text{C}$ . For  $I_{CC}$ , all typical values are at  $V_{CCP} = V_{CCI} = 3.3\text{ V}$  and  $T_A = 25^\circ\text{C}$ .

## I<sup>2</sup>C INTERFACE TIMING REQUIREMENTS

over recommended operating free-air temperature range (unless otherwise noted) (see [Figure 10](#))

		STANDARD MODE I <sup>2</sup> C BUS		FAST MODE I <sup>2</sup> C BUS		UNIT
		MIN	MAX	MIN	MAX	
f <sub>scl</sub>	I <sup>2</sup> C clock frequency	0	100	0	400	kHz
t <sub>sch</sub>	I <sup>2</sup> C clock high time	4		0.6		μs
t <sub>scl</sub>	I <sup>2</sup> C clock low time	4.7		1.3		μs
t <sub>sp</sub>	I <sup>2</sup> C spike time	0	50	0	50	ns
t <sub>sds</sub>	I <sup>2</sup> C serial data setup time	250		100		ns
t <sub>sdh</sub>	I <sup>2</sup> C serial data hold time	0		0		ns
t <sub>icr</sub>	I <sup>2</sup> C input rise time		1000	20 + 0.1C <sub>b</sub> <sup>(1)</sup>	300	ns
t <sub>icf</sub>	I <sup>2</sup> C input fall time		300	20 + 0.1C <sub>b</sub> <sup>(1)</sup>	300	ns
t <sub>ocf</sub>	I <sup>2</sup> C output fall time; 10 pF to 400 pF bus		300	20 + 0.1C <sub>b</sub> <sup>(1)</sup>	300	μs
t <sub>buf</sub>	I <sup>2</sup> C bus free time between Stop and Start	4.7		1.3		μs
t <sub>sts</sub>	I <sup>2</sup> C Start or repeater Start condition setup time	4.7		0.6		μs
t <sub>sth</sub>	I <sup>2</sup> C Start or repeater Start condition hold time	4		0.6		μs
t <sub>sps</sub>	I <sup>2</sup> C Stop condition setup time	4		0.6		μs
t <sub>vd(data)</sub>	Valid data time; SCL low to SDA output valid		1		1	μs
t <sub>vd(ack)</sub>	Valid data time of ACK condition; ACK signal from SCL low to SDA (out) low		1		1	μs

(1) C<sub>b</sub> = total capacitance of one bus line in pF

## RESET TIMING REQUIREMENTS

over recommended operating free-air temperature range (unless otherwise noted) (see [Figure 13](#))

		STANDARD MODE I <sup>2</sup> C BUS		FAST MODE I <sup>2</sup> C BUS		UNIT
		MIN	MAX	MIN	MAX	
t <sub>W</sub>	Reset pulse duration	4		4		ns
t <sub>REC</sub>	Reset recovery time	0		0		ns
t <sub>RESET</sub>	Time to reset <sup>(1)</sup>	600		600		ns

(1) Minimum time for SDA to become high or minimum time to wait before doing a START.



## SWITCHING CHARACTERISTICS

over recommended operating free-air temperature range,  $C_L \leq 100$  pF (unless otherwise noted) (see [Figure 10](#))

PARAMETER	FROM	TO	STANDARD MODE I <sup>2</sup> C BUS		FAST MODE I <sup>2</sup> C BUS		UNIT
			MIN	MAX	MIN	MAX	
t <sub>IV</sub> Interrupt valid time	P port	$\overline{\text{INT}}$		4		4	μs
t <sub>IR</sub> Interrupt reset delay time	SCL	$\overline{\text{INT}}$		4		4	μs
t <sub>PV</sub> Output data valid	SCL	P27–P00		400		400	ns
t <sub>PS</sub> Input data setup time	P port	SCL	0		0		ns
t <sub>PH</sub> Input data hold time	P port	SCL	300		300		ns

**TYPICAL CHARACTERISTICS**

$T_A = 25^\circ\text{C}$  (unless otherwise noted)

**SUPPLY CURRENT vs TEMPERATURE**

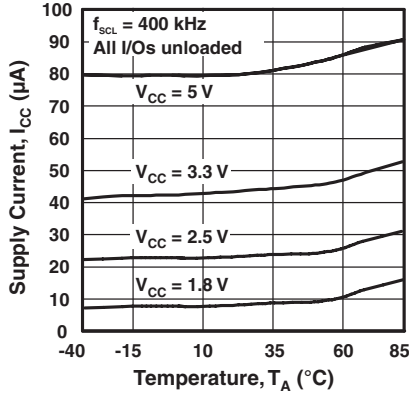

**STANDBY SUPPLY CURRENT vs TEMPERATURE**

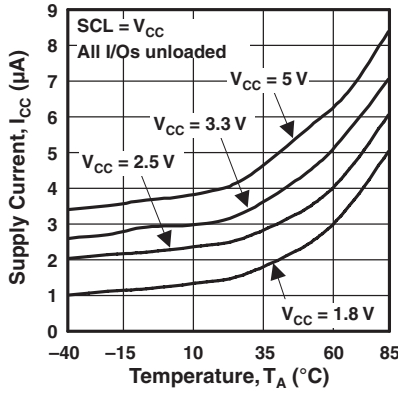

**SUPPLY CURRENT vs SUPPLY VOLTAGE**

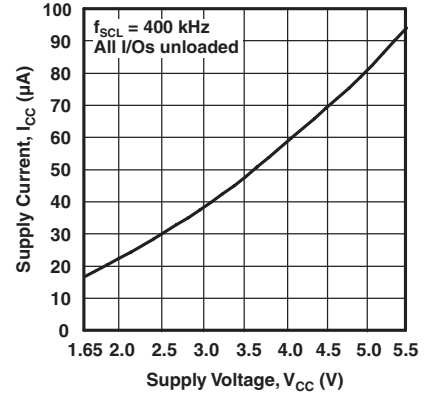

**I/O SINK CURRENT vs OUTPUT LOW VOLTAGE**

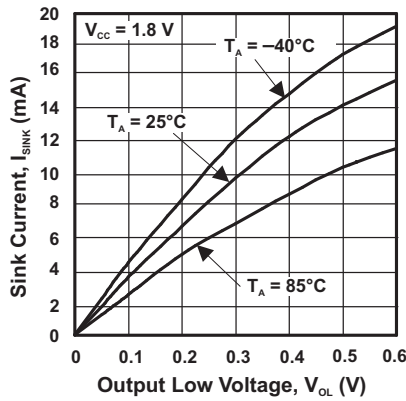

**I/O SINK CURRENT vs OUTPUT LOW VOLTAGE**

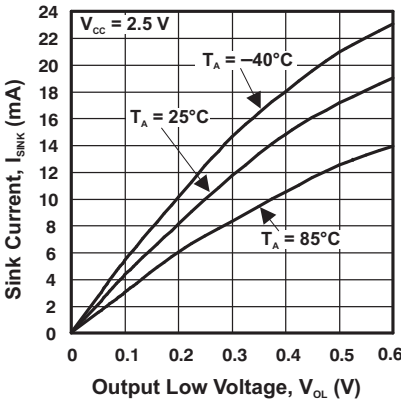

**I/O SINK CURRENT vs OUTPUT LOW VOLTAGE**

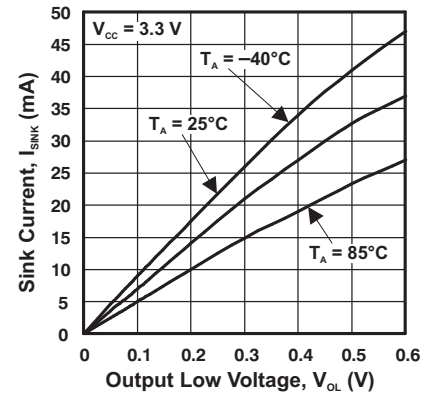

**I/O SINK CURRENT vs OUTPUT LOW VOLTAGE**

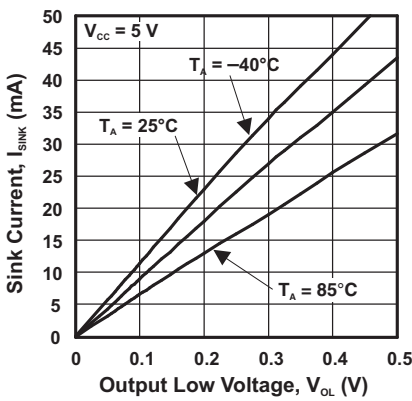

**I/O LOW VOLTAGE vs TEMPERATURE**

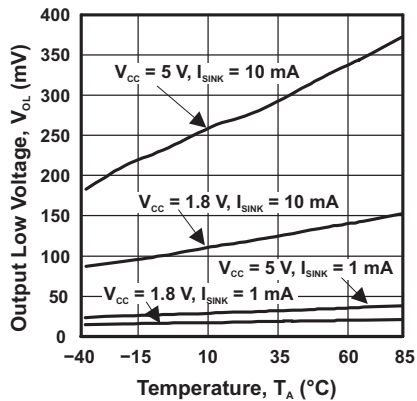

**I/O SOURCE CURRENT vs OUTPUT HIGH VOLTAGE**

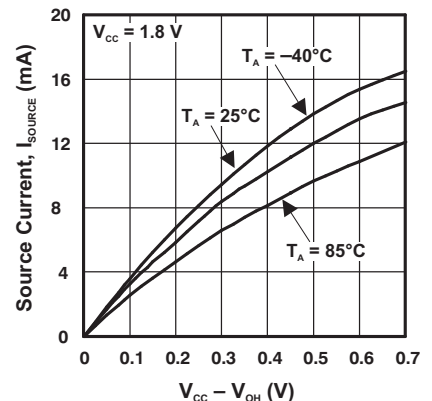

TYPICAL CHARACTERISTICS (continued)

$T_A = 25^\circ\text{C}$  (unless otherwise noted)

I/O SOURCE CURRENT vs OUTPUT HIGH VOLTAGE

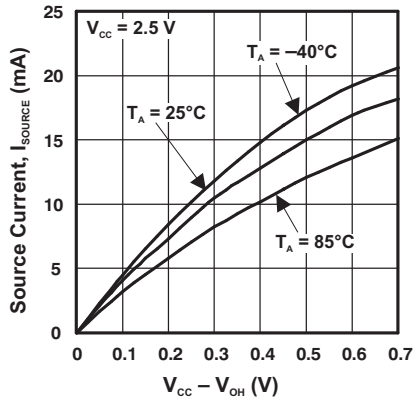

I/O SOURCE CURRENT vs OUTPUT HIGH VOLTAGE

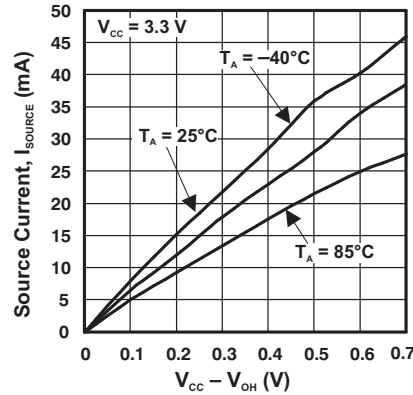

I/O SOURCE CURRENT vs OUTPUT HIGH VOLTAGE

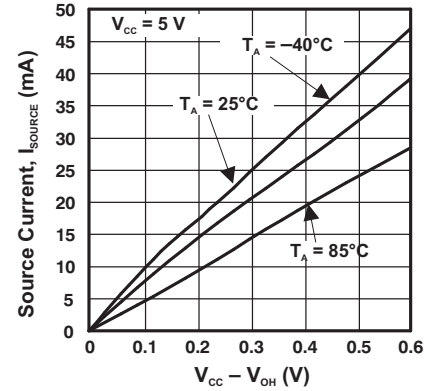

I/O HIGH VOLTAGE vs TEMPERATURE

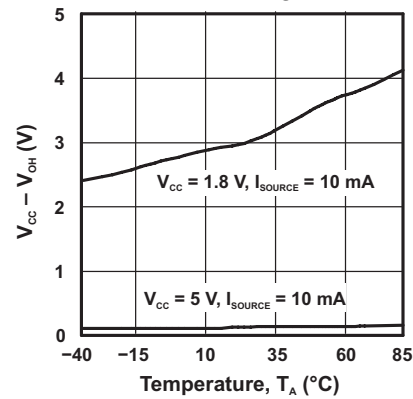

PARAMETER MEASUREMENT INFORMATION

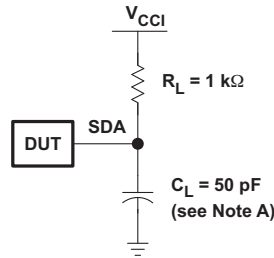

SDA LOAD CONFIGURATION

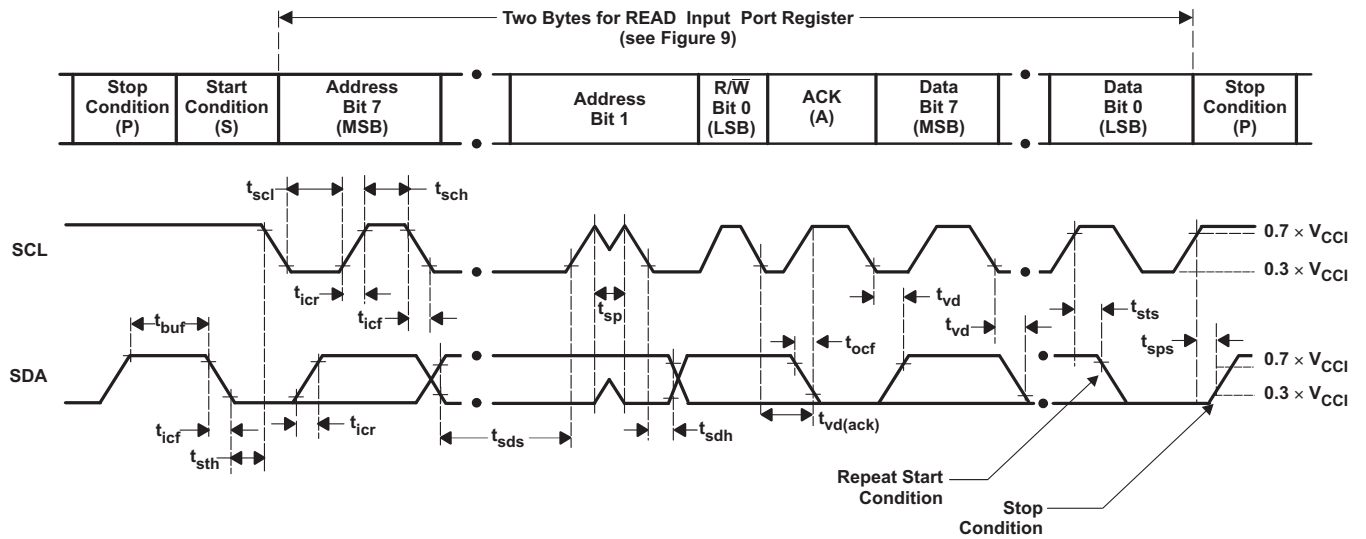

VOLTAGE WAVEFORMS

BYTE	DESCRIPTION
1	I <sup>2</sup> C address
2	Input register port data

- A.  $C_L$  includes probe and jig capacitance.  $t_{ocf}$  is measured with  $C_L$  of 10 pF or 400 pF.
- B. All inputs are supplied by generators having the following characteristics:  $PRR \leq 10$  MHz,  $Z_O = 50 \Omega$ ,  $t_r/t_f \leq 30$  ns.
- C. All parameters and waveforms are not applicable to all devices.

Figure 10. I<sup>2</sup>C Interface Load Circuit and Voltage Waveforms

PARAMETER MEASUREMENT INFORMATION (continued)

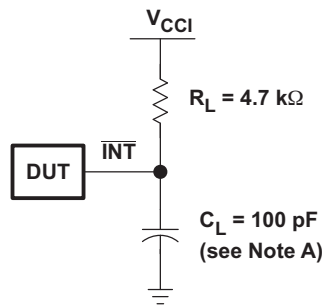

INTERRUPT LOAD CONFIGURATION

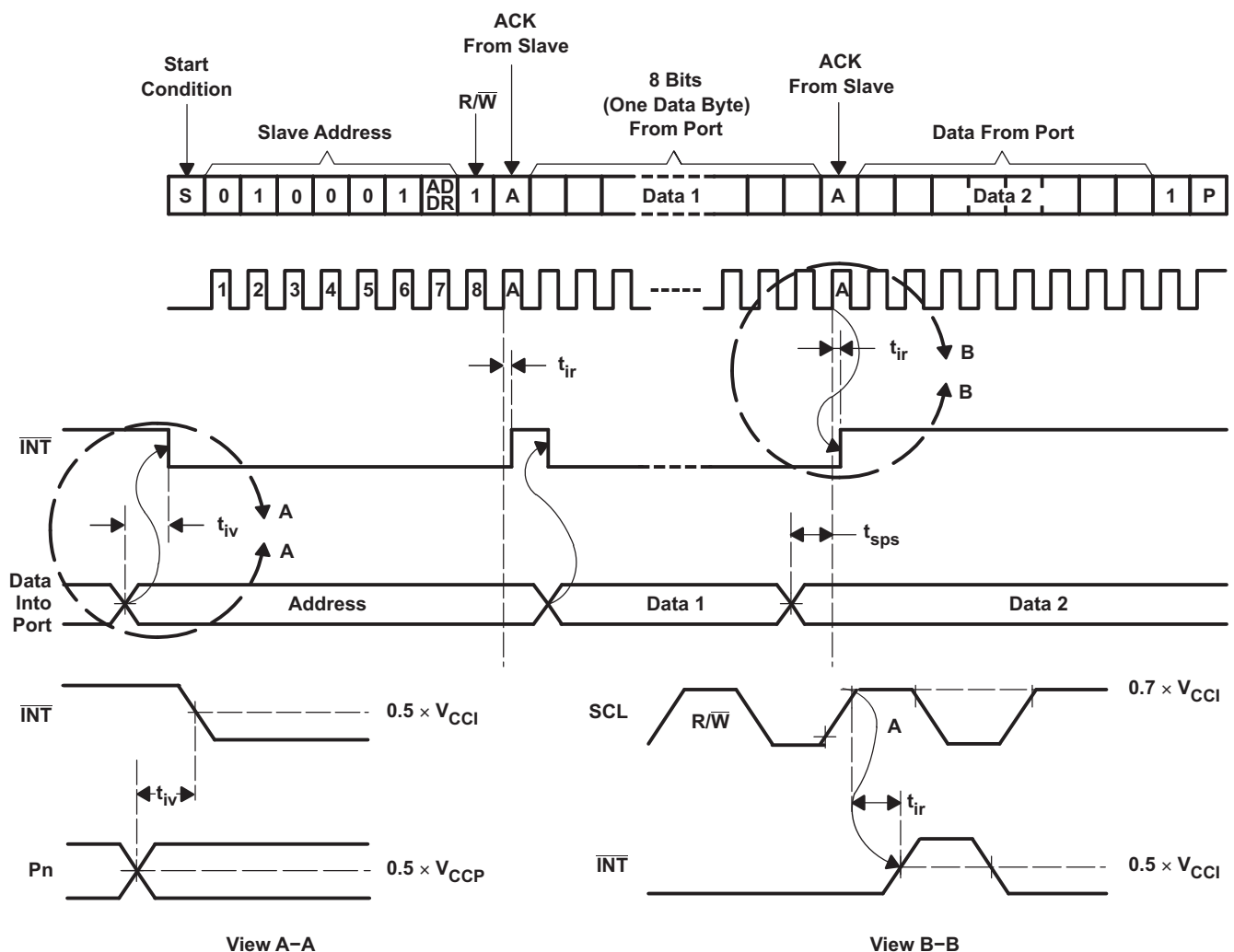

- A.  $C_L$  includes probe and jig capacitance.
- B. All inputs are supplied by generators having the following characteristics: PRR  $\leq$  10 MHz,  $Z_O = 50 \Omega$ ,  $t_r/t_f \leq 30$  ns.
- C. All parameters and waveforms are not applicable to all devices.

Figure 11. Interrupt Load Circuit and Voltage Waveforms

### PARAMETER MEASUREMENT INFORMATION (continued)

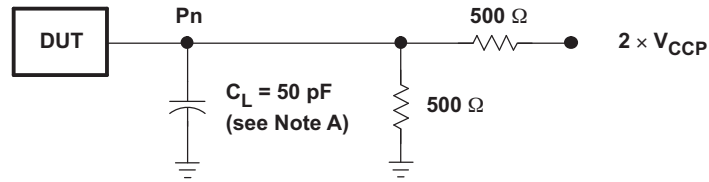

P PORT LOAD CONFIGURATION

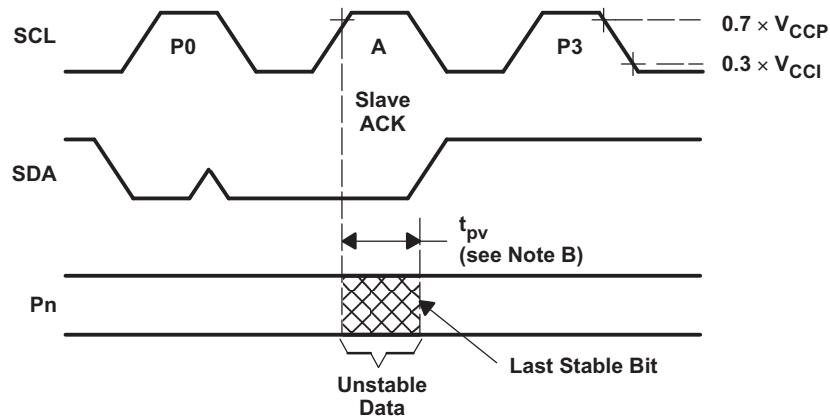

WRITE MODE ( $R/\bar{W} = 0$ )

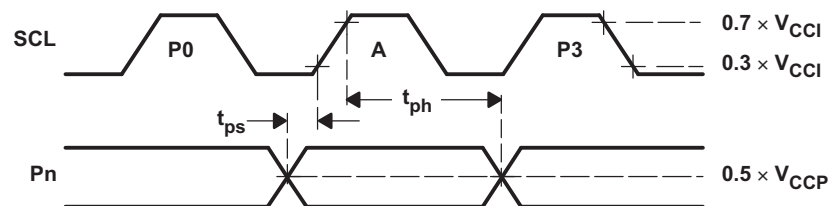

READ MODE ( $R/\bar{W} = 1$ )

- $C_L$  includes probe and jig capacitance.
- $t_{pv}$  is measured from  $0.7 \times V_{CC}$  on SCL to 50% I/O (Pn) output.
- All inputs are supplied by generators having the following characteristics:  $PRR \leq 10$  MHz,  $Z_0 = 50 \Omega$ ,  $t_r/t_f \leq 30$  ns.
- The outputs are measured one at a time, with one transition per measurement.
- All parameters and waveforms are not applicable to all devices.

**Figure 12. P-Port Load Circuit and Timing Waveforms**

PARAMETER MEASUREMENT INFORMATION (continued)

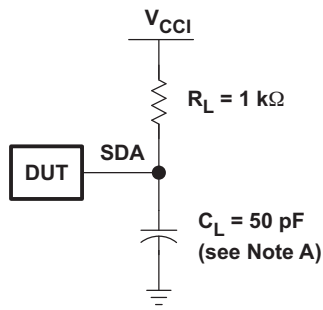

SDA LOAD CONFIGURATION

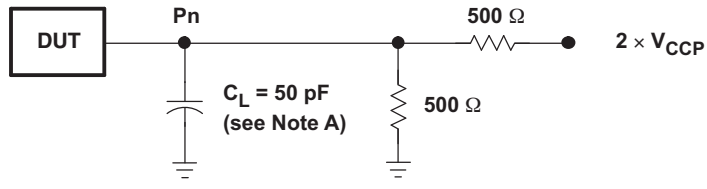

P PORT LOAD CONFIGURATION

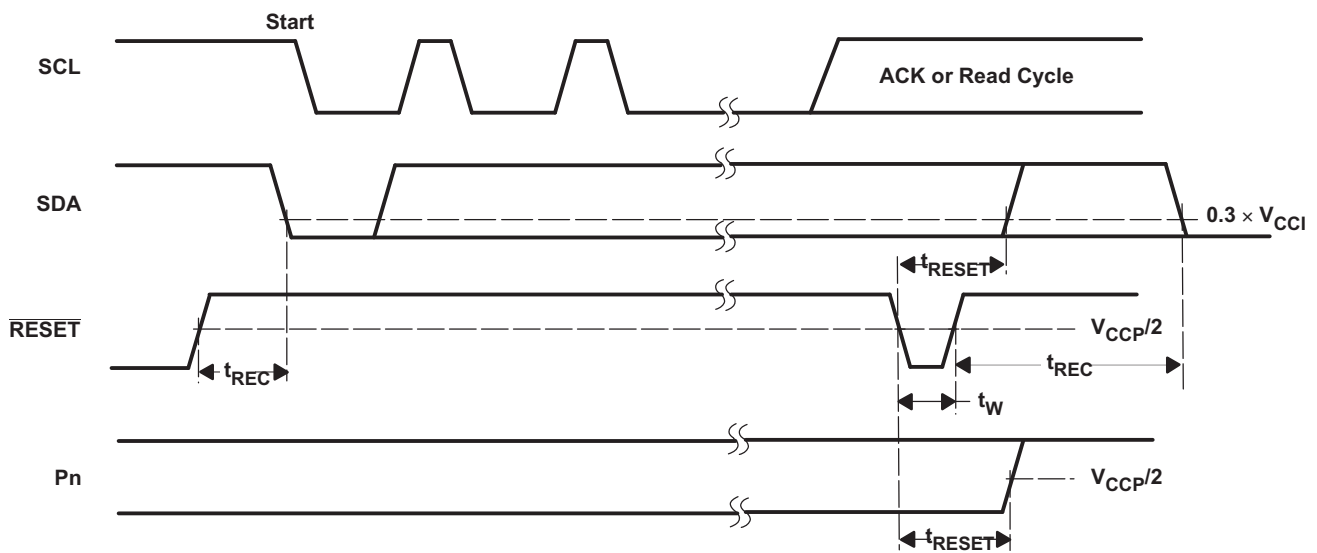

- A.  $C_L$  includes probe and jig capacitance.
- B. All inputs are supplied by generators having the following characteristics: PRR  $\leq 10\text{ MHz}$ ,  $Z_O = 50\ \Omega$ ,  $t_r/t_f \leq 30\text{ ns}$ .
- C. The outputs are measured one at a time, with one transition per measurement.
- D. I/Os are configured as inputs.
- E. All parameters and waveforms are not applicable to all devices.

Figure 13. Reset Load Circuits and Voltage Waveforms

APPLICATION INFORMATION

Figure 14 shows an application in which the TCA6424A can be used.

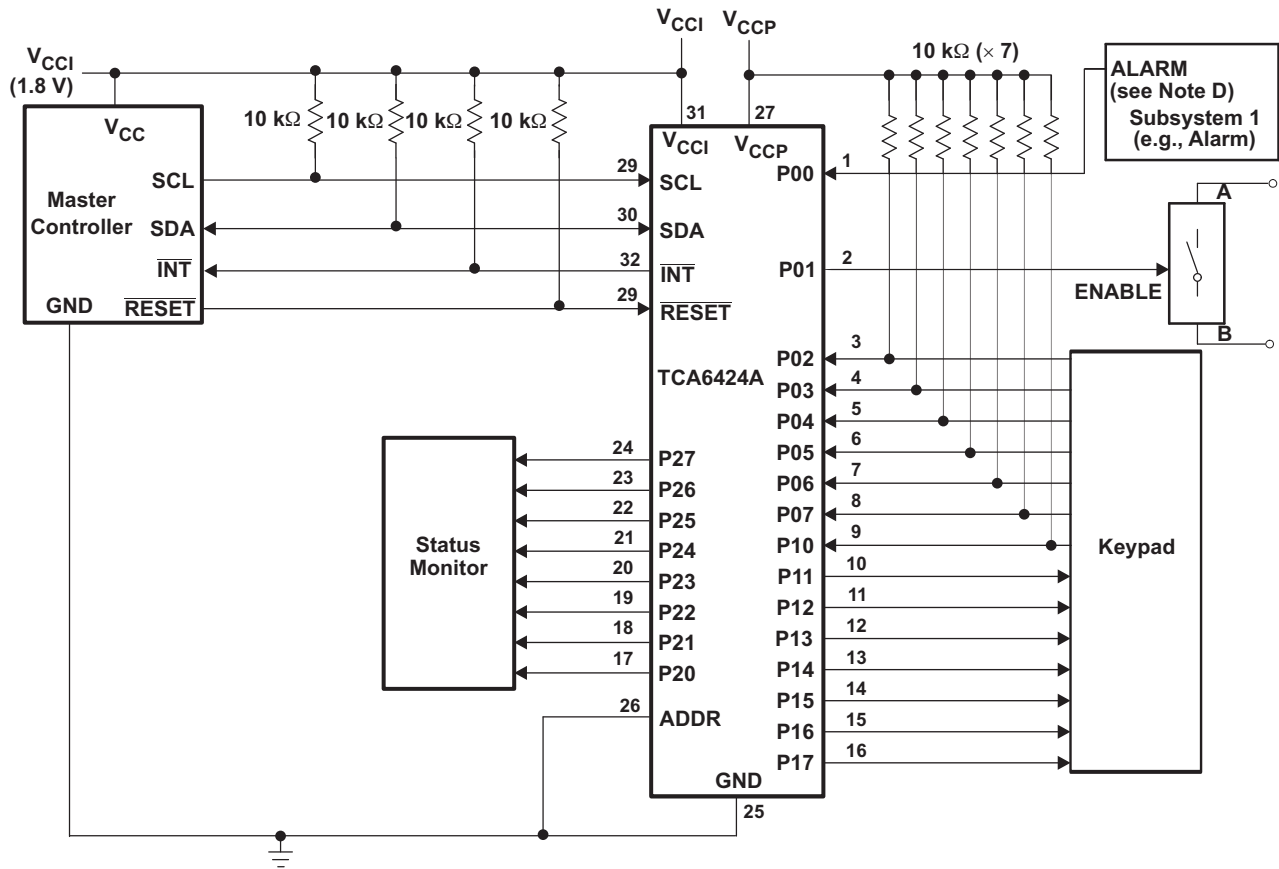

- A. Device address configured as 0100000 for this example.
- B. P00 and P02–P10 are configured as inputs.
- C. P01, P11–P17, and P20–P27 are configured as outputs.
- D. Resistors are required for inputs (on P port) that may float. If a driver to an input will not let the input float, a resistor is not needed. Outputs (in the P port) do not need pullup resistors.

Figure 14. Typical Application



## Minimizing $I_{CC}$ When I/Os Control LEDs

When the I/Os are used to control LEDs, normally they are connected to  $V_{CC}$  through a resistor as shown in Figure 14. The LED acts as a diode so, when the LED is off, the I/O  $V_{IN}$  is about 1.2 V less than  $V_{CC}$ . The  $\Delta I_{CC}$  parameter in Electrical Characteristics shows how  $I_{CC}$  increases as  $V_{IN}$  becomes lower than  $V_{CC}$ . Designs that must minimize current consumption, such as battery power applications, should consider maintaining the I/O pins greater than or equal to  $V_{CC}$  when the LED is off.

Figure 15 shows a high-value resistor in parallel with the LED. Figure 16 shows  $V_{CC}$  less than the LED supply voltage by at least 1.2 V. Both of these methods maintain the I/O  $V_{IN}$  at or above  $V_{CC}$  and prevent additional supply current consumption when the LED is off.

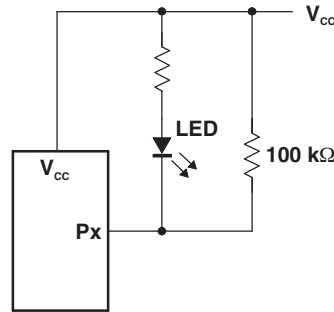

Figure 15. High-Value Resistor in Parallel With the LED

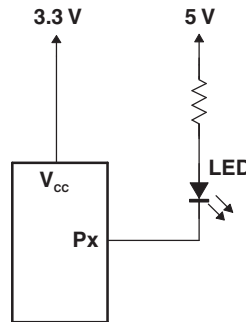

Figure 16. Device Supplied by a Low Voltage

## Power-On Reset Requirements

In the event of a glitch or data corruption, TCA6424A can be reset to its default conditions by using the power-on reset feature. Power-on reset requires that the device go through a power cycle to be completely reset. This reset also happens when the device is powered on for the first time in an application.

The two types of power-on reset are shown in Figure 17 and Figure 18.

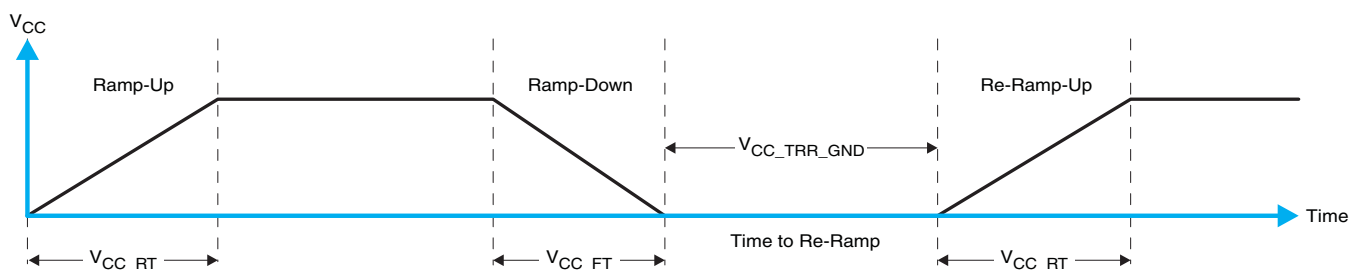
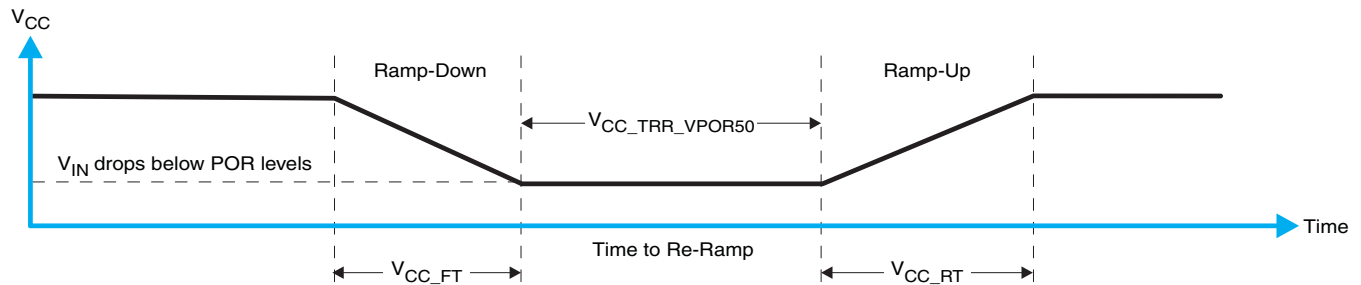

Figure 17.  $V_{CC}$  is Lowered Below 0.2 V or 0 V and Then Ramped Up to  $V_{CC}$



**Figure 18.  $V_{CC}$  is Lowered Below the POR Threshold, Then Ramped Back Up to  $V_{CC}$**

Table 10 specifies the performance of the power-on reset feature for TCA6424A for both types of power-on reset.

**Table 10. Recommended Supply Sequencing and Rates <sup>(1)</sup>**

PARAMETER			MIN	TYP	MAX	UNIT
$t_{VCC\_FT}$	Fall rate	See Figure 17	1		100	ms
$t_{VCC\_RT}$	Rise rate	See Figure 17	0.01		100	ms
$t_{VCC\_TRR\_GND}$	Time to re-ramp (when $V_{CC}$ drops to GND)	See Figure 17	40			$\mu$ s
$t_{VCC\_TRR\_POR50}$	Time to re-ramp (when $V_{CC}$ drops to $V_{POR\_MIN} - 50$ mV)	See Figure 18	40			$\mu$ s
$V_{CC\_GH}$	Level that $V_{CCP}$ can glitch down to, but not cause a functional disruption when $V_{CCX\_GW} = 1$ $\mu$ s	See Figure 19			1.2	V
$t_{VCC\_GW}$	Glitch width that will not cause a functional disruption when $V_{CCX\_GH} = 0.5 \times V_{CCx}$	See Figure 19			10	$\mu$ s
$V_{PORF}$	Voltage trip point of POR on falling $V_{CC}$		0.767		1.144	V
$V_{PORR}$	Voltage trip point of POR on rising $V_{CC}$		1.033		1.428	V

(1)  $T_A = -40^\circ\text{C}$  to  $85^\circ\text{C}$  (unless otherwise noted)

Glitches in the power supply can also affect the power-on reset performance of this device. The glitch width ( $V_{CC\_GW}$ ) and height ( $V_{CC\_GH}$ ) are dependent on each other. The bypass capacitance, source impedance, and device impedance are factors that affect power-on reset performance. Figure 19 and Table 10 provide more information on how to measure these specifications.

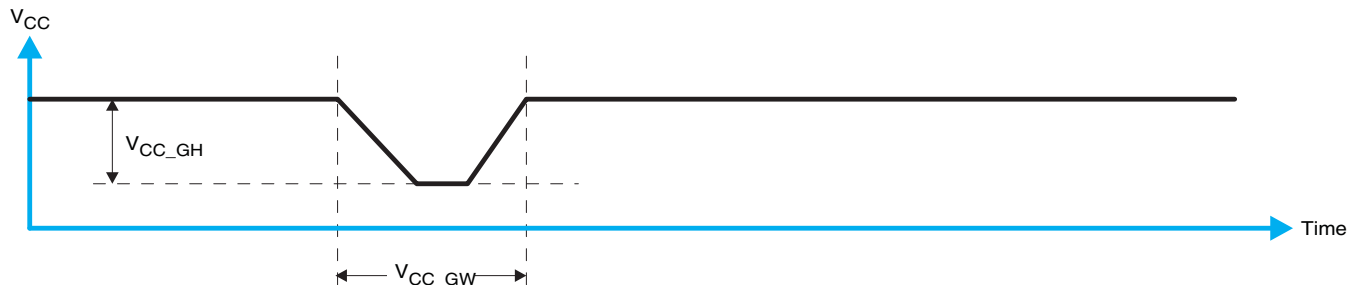

**Figure 19. Glitch Width and Glitch Height**

$V_{POR}$  is critical to the power-on reset.  $V_{POR}$  is the voltage level at which the reset condition is released and all the registers and the I<sup>2</sup>C/SMBus state machine are initialized to their default states. The value of  $V_{POR}$  differs based on the  $V_{CC}$  being lowered to or from 0. Figure 20 and Table 10 provide more details on this specification.

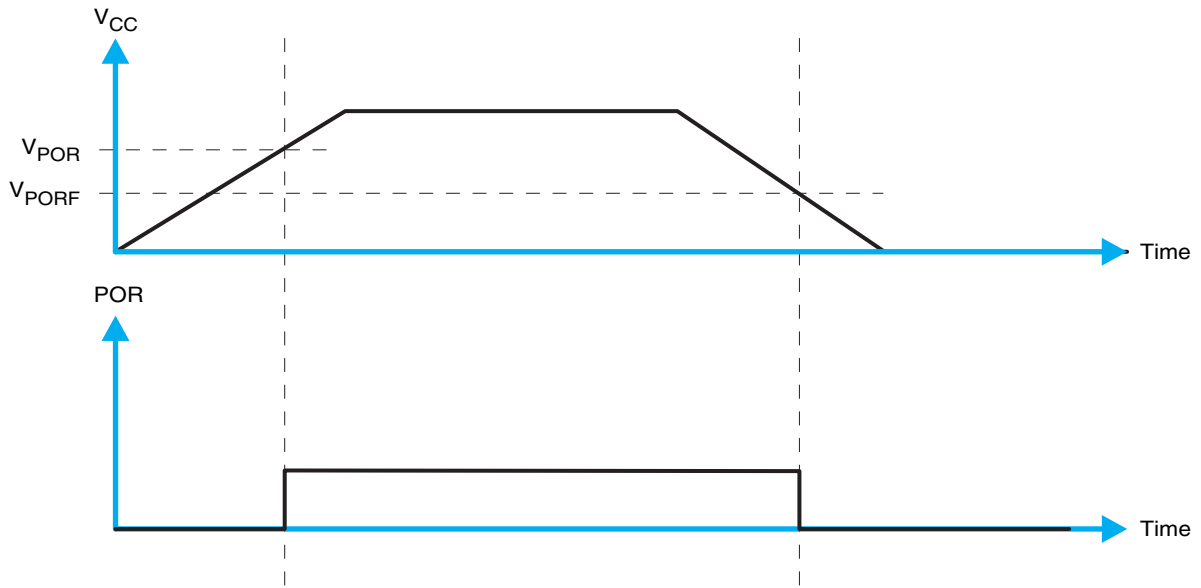

Figure 20.  $V_{POR}$

## REVISION HISTORY

Changes from Original (July 2010) to Revision A	Page
• Changed Recommended Supply Sequencing and Rates Table .....	<a href="#">26</a>

**PACKAGING INFORMATION**

Orderable Device	Status <sup>(1)</sup>	Package Type	Package Drawing	Pins	Package Qty	Eco Plan <sup>(2)</sup>	Lead/ Ball Finish	MSL Peak Temp <sup>(3)</sup>	Samples (Requires Login)
TCA6424ARGJR	ACTIVE	UQFN	RGJ	32	3000	Green (RoHS & no Sb/Br)	CU NIPDAU	Level-1-260C-UNLIM	<a href="#">Request Free Samples</a>

<sup>(1)</sup> The marketing status values are defined as follows:

**ACTIVE:** Product device recommended for new designs.

**LIFEBUY:** TI has announced that the device will be discontinued, and a lifetime-buy period is in effect.

**NRND:** Not recommended for new designs. Device is in production to support existing customers, but TI does not recommend using this part in a new design.

**PREVIEW:** Device has been announced but is not in production. Samples may or may not be available.

**OBSOLETE:** TI has discontinued the production of the device.

<sup>(2)</sup> Eco Plan - The planned eco-friendly classification: Pb-Free (RoHS), Pb-Free (RoHS Exempt), or Green (RoHS & no Sb/Br) - please check <http://www.ti.com/productcontent> for the latest availability information and additional product content details.

**TBD:** The Pb-Free/Green conversion plan has not been defined.

**Pb-Free (RoHS):** TI's terms "Lead-Free" or "Pb-Free" mean semiconductor products that are compatible with the current RoHS requirements for all 6 substances, including the requirement that lead not exceed 0.1% by weight in homogeneous materials. Where designed to be soldered at high temperatures, TI Pb-Free products are suitable for use in specified lead-free processes.

**Pb-Free (RoHS Exempt):** This component has a RoHS exemption for either 1) lead-based flip-chip solder bumps used between the die and package, or 2) lead-based die adhesive used between the die and leadframe. The component is otherwise considered Pb-Free (RoHS compatible) as defined above.

**Green (RoHS & no Sb/Br):** TI defines "Green" to mean Pb-Free (RoHS compatible), and free of Bromine (Br) and Antimony (Sb) based flame retardants (Br or Sb do not exceed 0.1% by weight in homogeneous material)

<sup>(3)</sup> MSL, Peak Temp. -- The Moisture Sensitivity Level rating according to the JEDEC industry standard classifications, and peak solder temperature.

**Important Information and Disclaimer:** The information provided on this page represents TI's knowledge and belief as of the date that it is provided. TI bases its knowledge and belief on information provided by third parties, and makes no representation or warranty as to the accuracy of such information. Efforts are underway to better integrate information from third parties. TI has taken and continues to take reasonable steps to provide representative and accurate information but may not have conducted destructive testing or chemical analysis on incoming materials and chemicals. TI and TI suppliers consider certain information to be proprietary, and thus CAS numbers and other limited information may not be available for release.

In no event shall TI's liability arising out of such information exceed the total purchase price of the TI part(s) at issue in this document sold by TI to Customer on an annual basis.

**TAPE AND REEL INFORMATION**

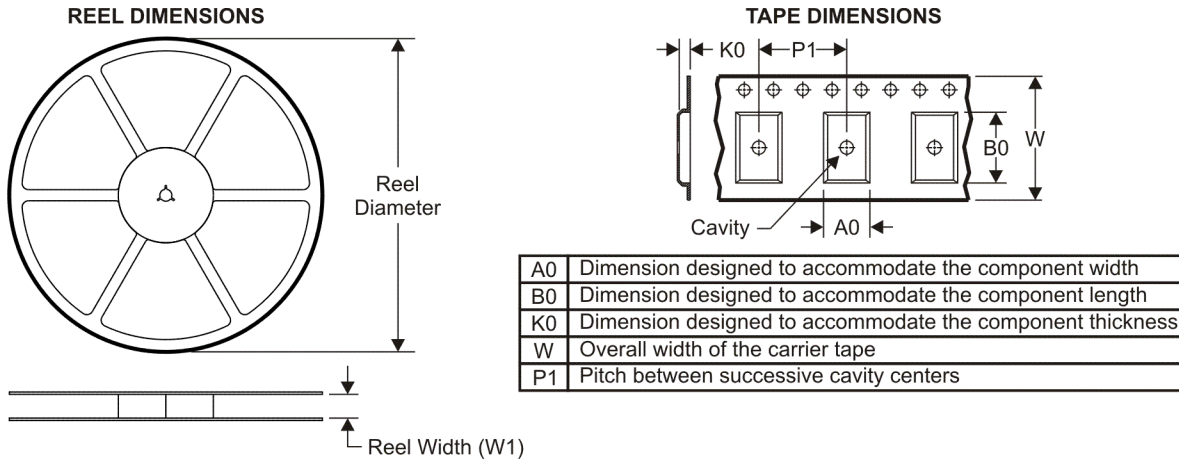

**QUADRANT ASSIGNMENTS FOR PIN 1 ORIENTATION IN TAPE**

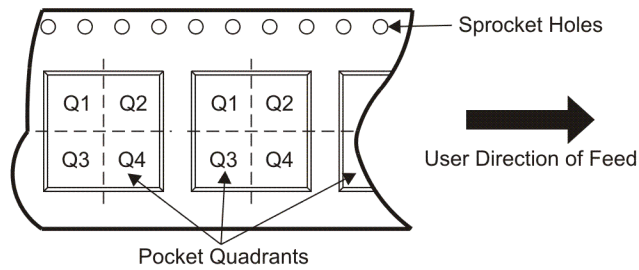

\*All dimensions are nominal

Device	Package Type	Package Drawing	Pins	SPQ	Reel Diameter (mm)	Reel Width W1 (mm)	A0 (mm)	B0 (mm)	K0 (mm)	P1 (mm)	W (mm)	Pin1 Quadrant
TCA6424ARGJR	UQFN	RGJ	32	3000	330.0	12.4	5.3	5.3	0.75	8.0	12.0	Q2

**TAPE AND REEL BOX DIMENSIONS**



\*All dimensions are nominal

Device	Package Type	Package Drawing	Pins	SPQ	Length (mm)	Width (mm)	Height (mm)
TCA6424ARGJR	UQFN	RGJ	32	3000	346.0	346.0	35.0

RGJ (S-PQFP-N32)

PLASTIC QUAD FLATPACK

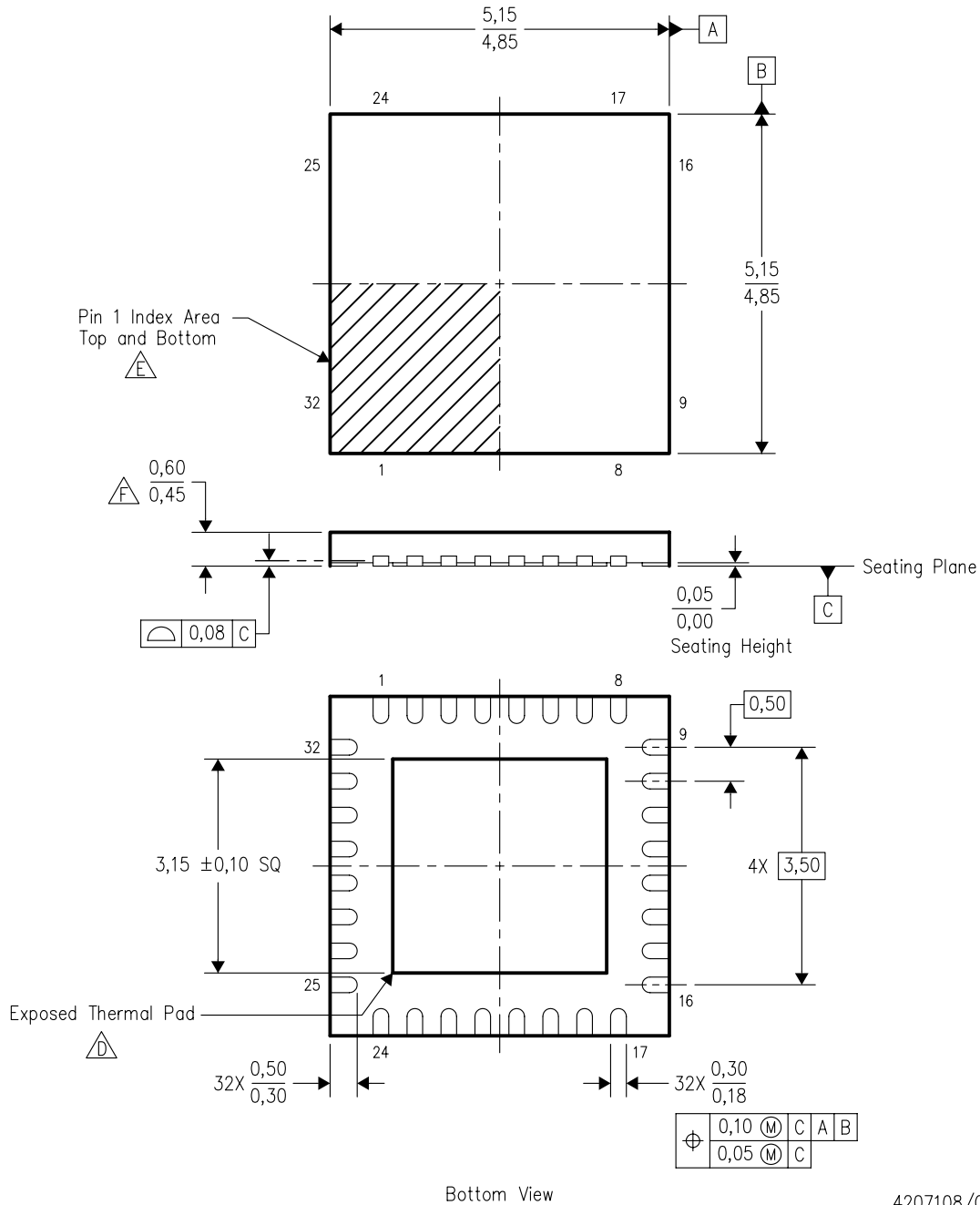

4207108/C 11/2005

- NOTES:
- A. All linear dimensions are in millimeters. Dimensioning and tolerancing per ASME Y14.5M-1994.
  - B. This drawing is subject to change without notice.
  - C. QFN (Quad Flatpack No-Lead) package configuration.
  - The package thermal pad must be soldered to the board for thermal and mechanical performance.
  - Pin 1 identifiers are located on both top and bottom of the package and within the zone indicated. The Pin 1 identifiers are either a molded, marked, or metal feature.
  - Complies to JEDEC MO-248 variation UHHD-1, except minimum package height.



## IMPORTANT NOTICE

Texas Instruments Incorporated and its subsidiaries (TI) reserve the right to make corrections, modifications, enhancements, improvements, and other changes to its products and services at any time and to discontinue any product or service without notice. Customers should obtain the latest relevant information before placing orders and should verify that such information is current and complete. All products are sold subject to TI's terms and conditions of sale supplied at the time of order acknowledgment.

TI warrants performance of its hardware products to the specifications applicable at the time of sale in accordance with TI's standard warranty. Testing and other quality control techniques are used to the extent TI deems necessary to support this warranty. Except where mandated by government requirements, testing of all parameters of each product is not necessarily performed.

TI assumes no liability for applications assistance or customer product design. Customers are responsible for their products and applications using TI components. To minimize the risks associated with customer products and applications, customers should provide adequate design and operating safeguards.

TI does not warrant or represent that any license, either express or implied, is granted under any TI patent right, copyright, mask work right, or other TI intellectual property right relating to any combination, machine, or process in which TI products or services are used. Information published by TI regarding third-party products or services does not constitute a license from TI to use such products or services or a warranty or endorsement thereof. Use of such information may require a license from a third party under the patents or other intellectual property of the third party, or a license from TI under the patents or other intellectual property of TI.

Reproduction of TI information in TI data books or data sheets is permissible only if reproduction is without alteration and is accompanied by all associated warranties, conditions, limitations, and notices. Reproduction of this information with alteration is an unfair and deceptive business practice. TI is not responsible or liable for such altered documentation. Information of third parties may be subject to additional restrictions.

Resale of TI products or services with statements different from or beyond the parameters stated by TI for that product or service voids all express and any implied warranties for the associated TI product or service and is an unfair and deceptive business practice. TI is not responsible or liable for any such statements.

TI products are not authorized for use in safety-critical applications (such as life support) where a failure of the TI product would reasonably be expected to cause severe personal injury or death, unless officers of the parties have executed an agreement specifically governing such use. Buyers represent that they have all necessary expertise in the safety and regulatory ramifications of their applications, and acknowledge and agree that they are solely responsible for all legal, regulatory and safety-related requirements concerning their products and any use of TI products in such safety-critical applications, notwithstanding any applications-related information or support that may be provided by TI. Further, Buyers must fully indemnify TI and its representatives against any damages arising out of the use of TI products in such safety-critical applications.

TI products are neither designed nor intended for use in military/aerospace applications or environments unless the TI products are specifically designated by TI as military-grade or "enhanced plastic." Only products designated by TI as military-grade meet military specifications. Buyers acknowledge and agree that any such use of TI products which TI has not designated as military-grade is solely at the Buyer's risk, and that they are solely responsible for compliance with all legal and regulatory requirements in connection with such use.

TI products are neither designed nor intended for use in automotive applications or environments unless the specific TI products are designated by TI as compliant with ISO/TS 16949 requirements. Buyers acknowledge and agree that, if they use any non-designated products in automotive applications, TI will not be responsible for any failure to meet such requirements.

Following are URLs where you can obtain information on other Texas Instruments products and application solutions:

<b>Products</b>		<b>Applications</b>	
Amplifiers	<a href="http://amplifier.ti.com">amplifier.ti.com</a>	Audio	<a href="http://www.ti.com/audio">www.ti.com/audio</a>
Data Converters	<a href="http://dataconverter.ti.com">dataconverter.ti.com</a>	Automotive	<a href="http://www.ti.com/automotive">www.ti.com/automotive</a>
DLP® Products	<a href="http://www.dlp.com">www.dlp.com</a>	Communications and Telecom	<a href="http://www.ti.com/communications">www.ti.com/communications</a>
DSP	<a href="http://dsp.ti.com">dsp.ti.com</a>	Computers and Peripherals	<a href="http://www.ti.com/computers">www.ti.com/computers</a>
Clocks and Timers	<a href="http://www.ti.com/clocks">www.ti.com/clocks</a>	Consumer Electronics	<a href="http://www.ti.com/consumer-apps">www.ti.com/consumer-apps</a>
Interface	<a href="http://interface.ti.com">interface.ti.com</a>	Energy	<a href="http://www.ti.com/energy">www.ti.com/energy</a>
Logic	<a href="http://logic.ti.com">logic.ti.com</a>	Industrial	<a href="http://www.ti.com/industrial">www.ti.com/industrial</a>
Power Mgmt	<a href="http://power.ti.com">power.ti.com</a>	Medical	<a href="http://www.ti.com/medical">www.ti.com/medical</a>
Microcontrollers	<a href="http://microcontroller.ti.com">microcontroller.ti.com</a>	Security	<a href="http://www.ti.com/security">www.ti.com/security</a>
RFID	<a href="http://www.ti-rfid.com">www.ti-rfid.com</a>	Space, Avionics & Defense	<a href="http://www.ti.com/space-avionics-defense">www.ti.com/space-avionics-defense</a>
RF/IF and ZigBee® Solutions	<a href="http://www.ti.com/lprf">www.ti.com/lprf</a>	Video and Imaging	<a href="http://www.ti.com/video">www.ti.com/video</a>
		Wireless	<a href="http://www.ti.com/wireless-apps">www.ti.com/wireless-apps</a>