

TOSHIBA CMOS DIGITAL INTEGRATED CIRCUIT SILICON MONOLITHIC

TC9273N, TC9273F, TC9274N, TC9274F

ANALOG SWITCH ARRAY ICs

TC9273N, TC9273F, TC9274N and TC9274F are analog switch array ICs developed for use in audio equipment such as home stereo sets. Switch connection layouts can be customized for different sets, thus simplifying the external wiring.

FEATURES

- 10 analog switches × 2 channels built in : TC9273N
TC9273F
- 18 analog switches × 2 channels built in : TC9274N
TC9274F
- An aluminum mask process allows switch connections to be customized.
- Switches are controlled by serial data.
- Built-in 5V microcomputer interface.
- Shrink DIP or flat package.

Weight	
SDIP28-P-400-1.78	: 2.2g (Typ.)
SOP28-P-450-1.27	: 0.8g (Typ.)
SDIP42-P-600-1.78	: 4.2g (Typ.)
QFP44-P-1414-0.80D	: 1.1g (Typ.)

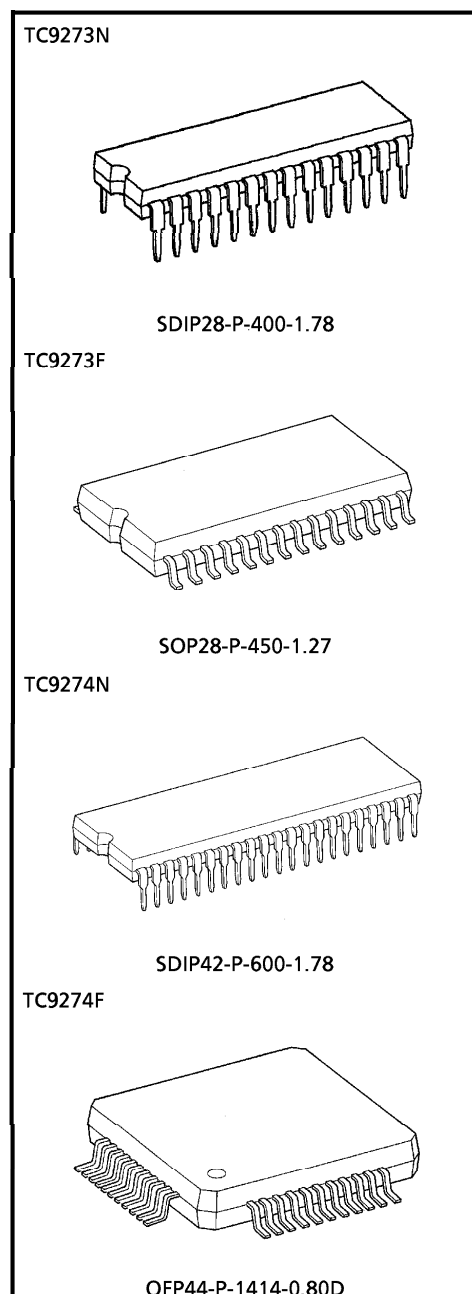

980508EBA2'

● The products described in this document are subject to foreign exchange and foreign trade laws.
 ● The information contained herein is presented only as a guide for the applications of our products. No responsibility is assumed by TOSHIBA CORPORATION for any infringements of intellectual property or other rights of the third parties which may result from its use. No license is granted by implication or otherwise under any intellectual property or other rights of TOSHIBA CORPORATION or others.
 ● The information contained herein is subject to change without notice.

PIN CONNECTION (TOP VIEW)

TC9273N, TC9273F

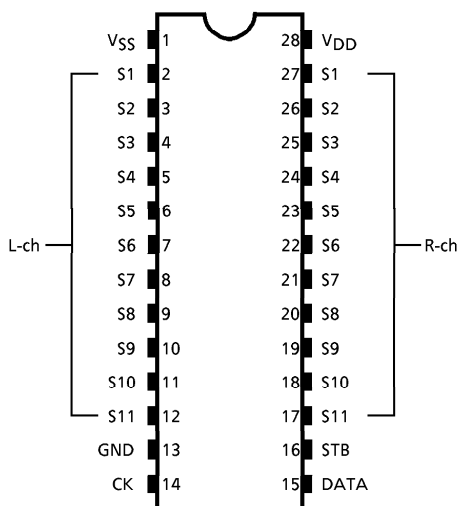

TC9274N

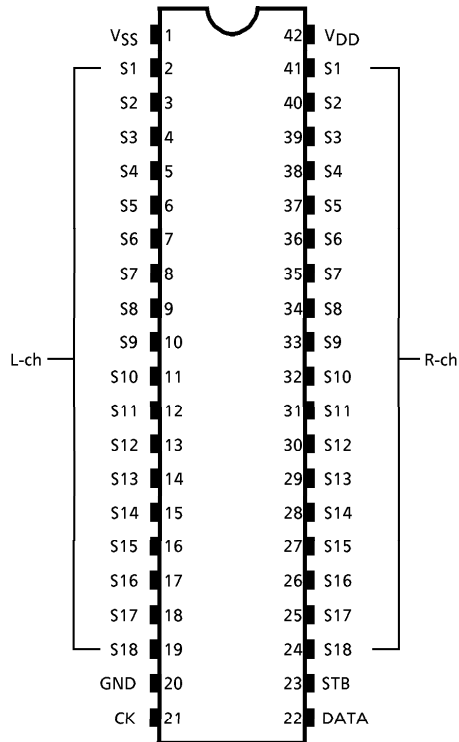

TC9274F

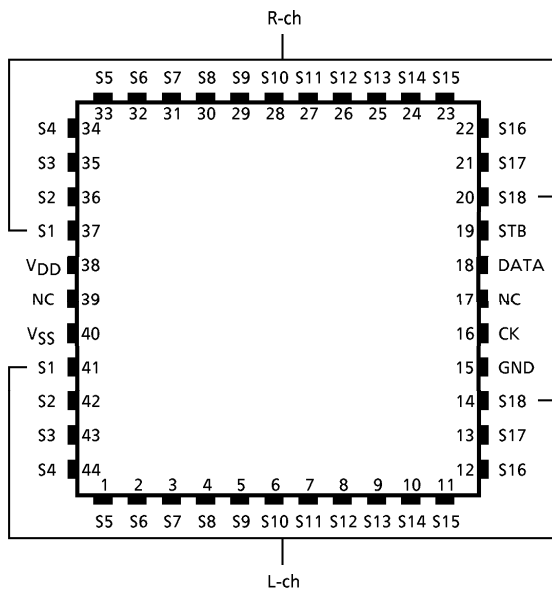

980508EBA2'

- The products described in this document are subject to foreign exchange and foreign trade laws.
- The information contained herein is presented only as a guide for the applications of our products. No responsibility is assumed by TOSHIBA CORPORATION for any infringements of intellectual property or other rights of the third parties which may result from its use. No license is granted by implication or otherwise under any intellectual property or other rights of TOSHIBA CORPORATION or others.
- The information contained herein is subject to change without notice.

BLOCK DIAGRAM

TC9273N, TC9273F

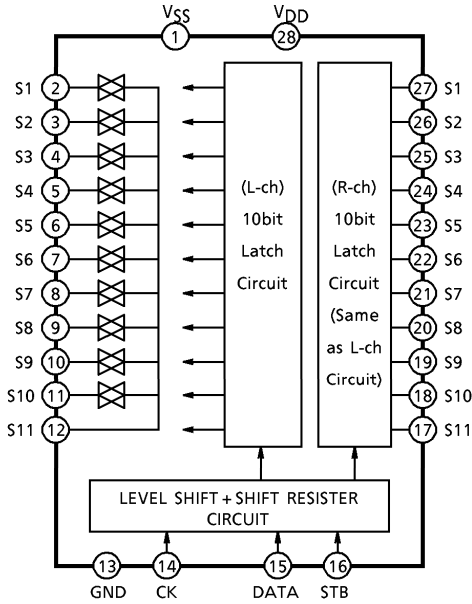

TC9274N

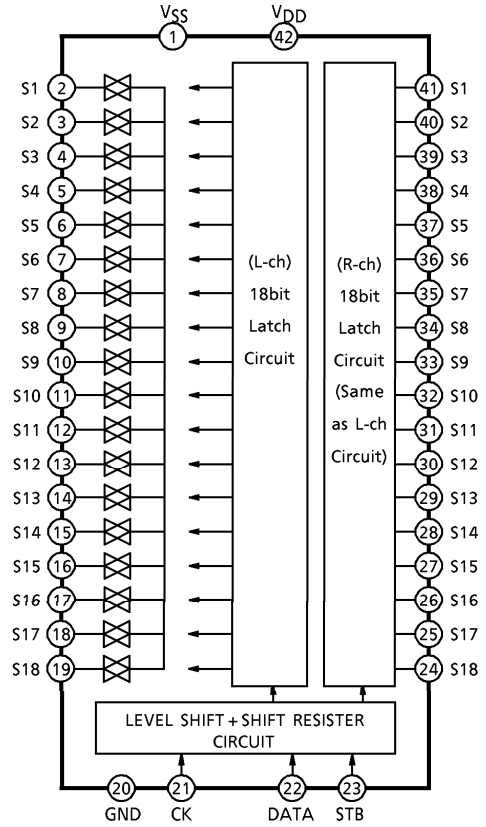

TC9274F

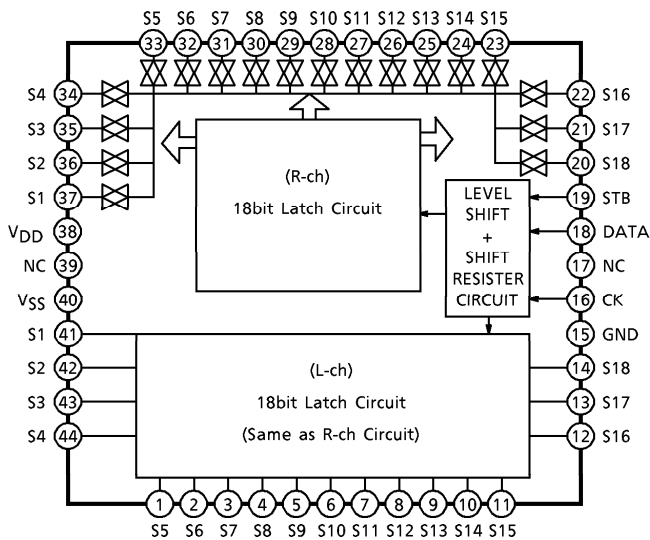

PIN FUNCTION (Left channel / right channel)

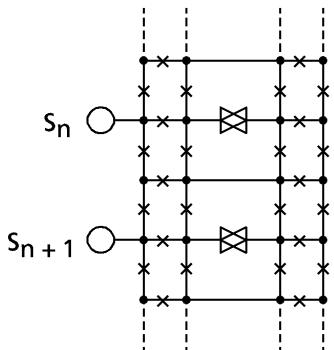
PIN No.			SYMBOL	PIN NAME	FUNCTION AND OPERATION	NOTE
TC9273N / F	TC9274N	TC9274F				
1	1	40	V _{SS}	Negative power supply pin	Dual power supply $V_{DD} = 8.0 \sim 17V$ $GND = 0V$ $V_{SS} = -8.0 \sim -17V$	—
13	20	16	GND	Digital ground pin		
28	42	38	V _{DD}	Positive power supply pin		
2 / 27	2 / 41	41 / 37	S1	Input / output pins	Analog switch input pins. 	—
3 / 26	3 / 40	42 / 36	S2			
4 / 25	4 / 39	43 / 35	S3			
5 / 24	5 / 38	44 / 34	S4			
6 / 23	6 / 37	1 / 33	S5			
7 / 22	7 / 36	2 / 32	S6			
8 / 21	8 / 35	3 / 31	S7			
9 / 20	9 / 34	4 / 30	S8			
10 / 19	10 / 33	5 / 29	S9			
11 / 18	11 / 32	6 / 28	S10			
12 / 17	12 / 31	7 / 27	S11			
—	13 / 30	8 / 26	S12			
—	14 / 29	9 / 25	S13			
—	15 / 28	10 / 24	S14			
—	16 / 27	11 / 23	S15			
—	17 / 26	12 / 22	S16			
—	18 / 25	13 / 21	S17			
—	19 / 24	14 / 20	S18			
—	—	17 / 39	NC	Not connected	—	—
14	21	16	CK	Clock input pin	Clock input for data transfer	Low threshold value input pins
15	22	18	DATA	Data input pin	Serial data input for setting switches	
16	23	19	STB	Strobe input pin	Strobe input for data writing	

× : Aluminum mask switch.
 ● : Open or closed can be specified. Connection for right and left channels can be different.

OPERATION

1. Switch ON/OFF setting

The switches are set to ON or OFF using 18bit or 26bit serial data.

• Data format

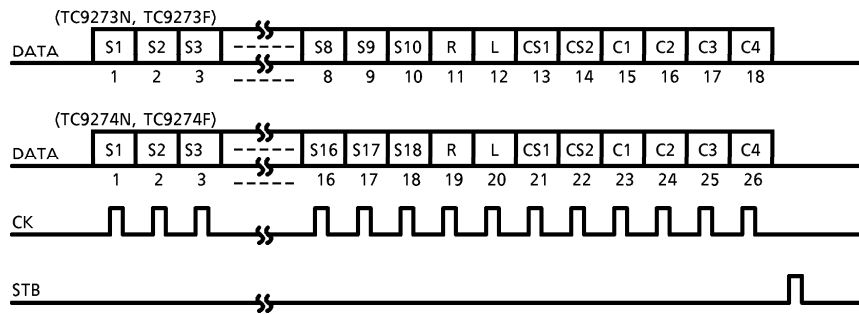

- 1) S₁~S₁₀~S₁₈ : Switch control data
 When S_n = 1, S_n is set to ON ; when S_n = 0, to OFF.
- 2) R and L : Channel select data
 When R = 1, right-channel switches are set ; when L = 1, left-channel switches are set.
 (When R=L=1, both channel switches are set simultaneously.)
- 3) CS1 and CS2 : Sub-code data
 The sub-code data are customized.
- 4) C₁~C₄ : Chip select data (fixed)

IC NAME	C ₁	C ₂	C ₃	C ₄
TC9273N, TC9273F	0	0	1	0
TC9274N, TC9274F	1	0	1	0

2. Serial data timing

Input the CK, DATA and STB signals at the following timing.

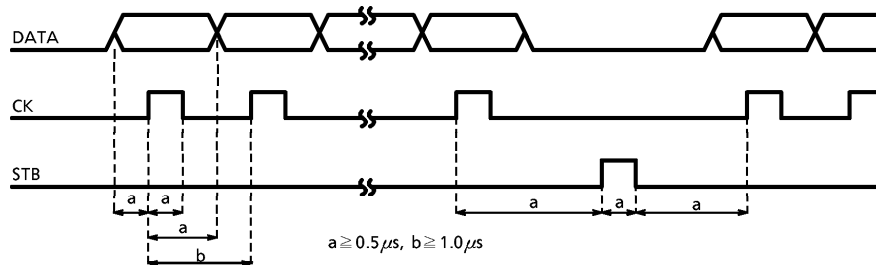

3. One and dual power supply operation

TC9273N, TC9273F, TC9274N and TC9274F can operate with one or dual power supply. With single or dual power supply, serial data logic level can be 0 – 5V.

• Single power supply operation

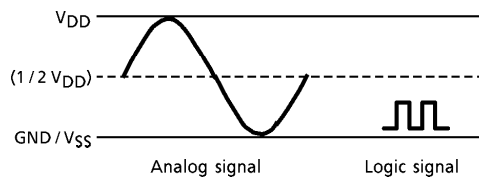

• Dual power supply operation

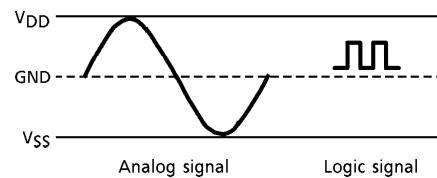

MAXIMUM RATINGS (Ta = 25°C)

CHARACTERISTIC	SYMBOL	RATING	UNIT
Power Supply Voltage (1)	$V_{DD} - V_{SS}$	-0.3~36	V
Power Supply Voltage (2)	$V_{DD} - GND$	-0.3~20	V
GND Input Voltage	$V_{IN} (1)$	-0.3~ $V_{DD} + 0.3$	V
V_{SS} Input Voltage	$V_{IN} (2)$	$V_{SS} - 0.3 \sim V_{DD} + 0.3$	V
Power Dissipation	P_D	300	mW
Operating Temperature	T_{opr}	-40~85	°C
Storage Temperature	T_{stg}	-65~150	°C

ELECTRICAL CHARACTERISTICS (Unless otherwise specified, $V_{DD} = 15V$, $V_{SS} = -15V$, $GND = 0V$, $T_a = 25^\circ C$)

CHARACTERISTIC	SYMBOL	TEST CIRCUIT	TEST CONDITION	MIN.	TYP.	MAX.	UNIT
Operating Supply Voltage (1)	$V_{DD} - V_{SS}$	—	Dual power supplying	16	~	34	V
Operating Supply Voltage (2)	$V_{DD} - GND$	—	Single power supplying	8	~	18	V
Operating Supply Current	I_{DD}	—	No-load, No-input	—	0.01	0.1	mA
Input Voltage	"H" Level	V_{IH}	CK, DATA, STB Terminal $V_{DD} = 8 \sim 18V$	4.0	~	V_{DD}	V
	"L" Level	V_{IL}		GND	~	1.0	
Input Current	"H" Level	I_{IH}	CK, DATA, STB Terminal	$V_{IH} = 15V$	~	1.0	μA
	"L" Level	I_{IL}		$V_{IL} = 0V$	~	1.0	
Operating Frequency	fop	—	CK, DATA, STB Terminal	0	~	1.0	MHz
Operating Minimum Clock Wide	Tck	—		0.5	—	—	μs
Switch-on Resistance	R_{ON}	—	Internal analog switch	—	80	100	Ω
Analog Switch OFF Leak	I_{OFF}	—		-0.1	~	0.1	μA
Total Harmonic Distortion	THD	1	$f_{IN} = 1kHz$, $V_{IN} = 1V_{rms}$ $R_g = 600\Omega$, $R_L = 47k\Omega$ $BW = 20Hz \sim 50kHz$	—	0.001	—	%
Noise Output Voltage	V_N			—	1.0	—	μV_{rms}
Crosstalk	C·T			—	100	—	dB

TEST CIRCUIT 1 (THD/ V_N /C-T)

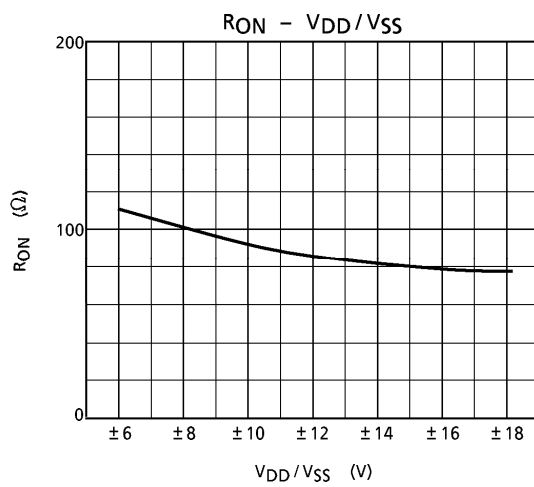
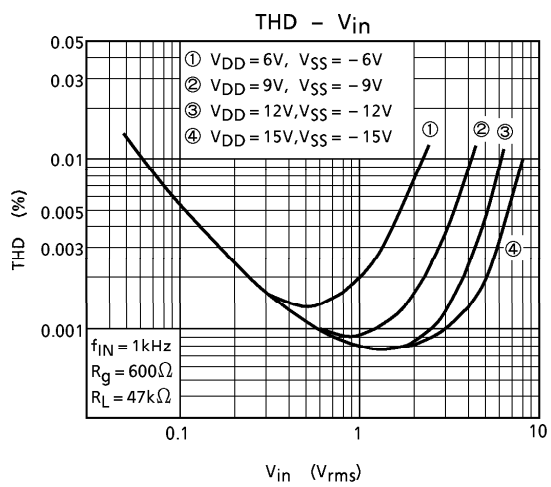
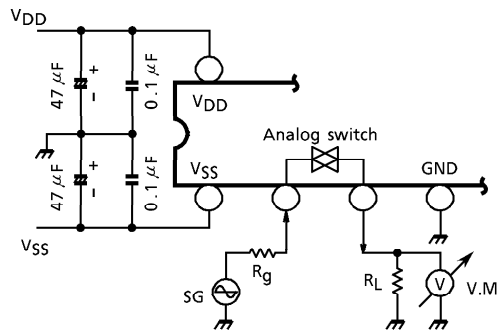

APPLICATION CIRCUIT

1) Typical switch connection for an application set. (N : Switch number)

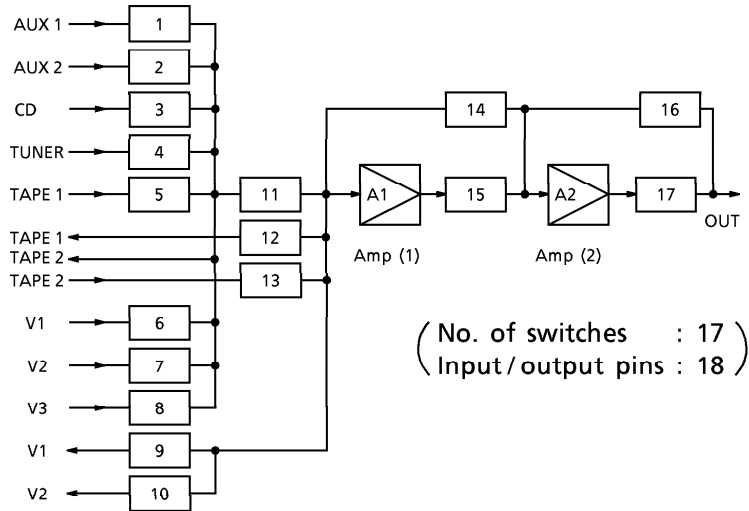

2) Typical switch array for the circuit above.

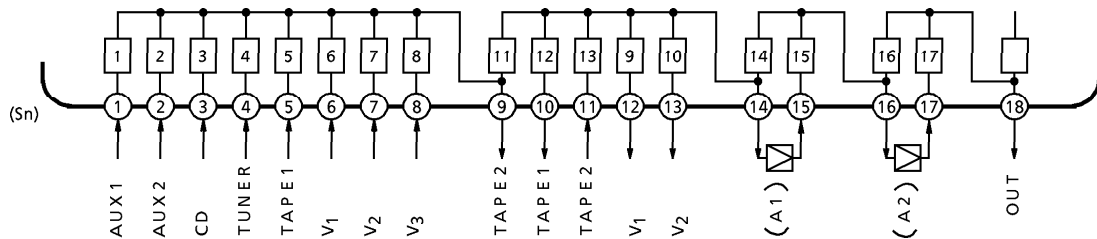

OUTLINE DRAWING
SDIP28-P-400-1.78

Unit : mm

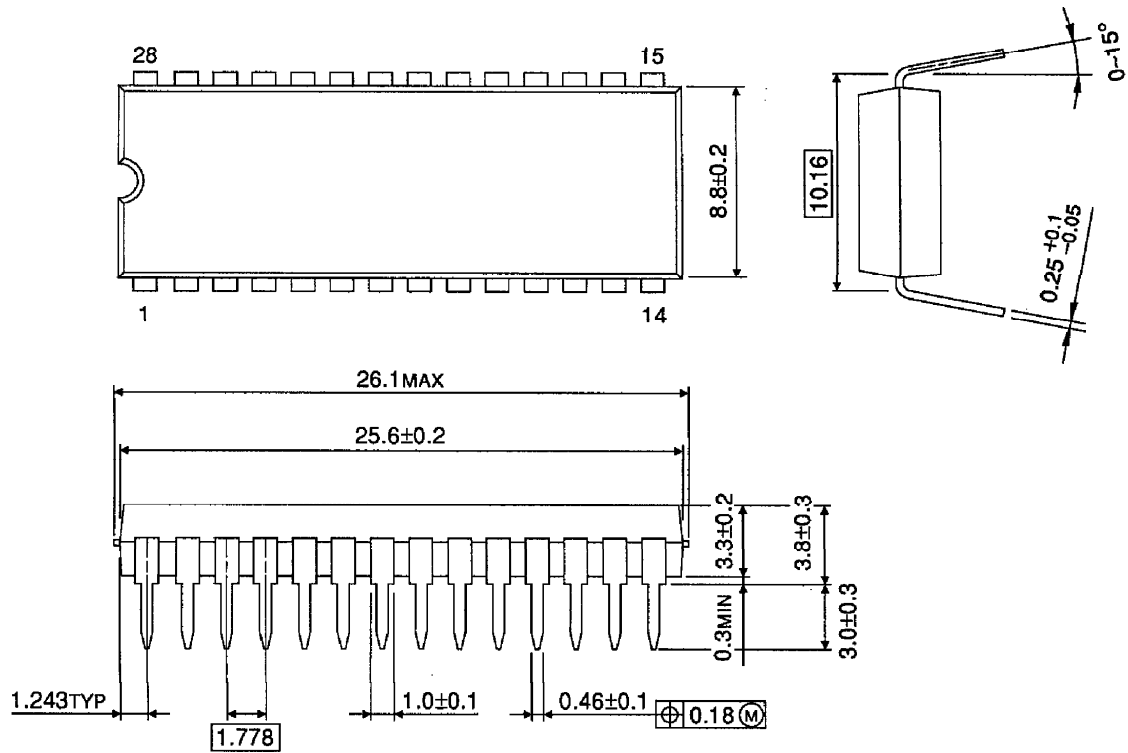

Weight : 2.2g (Typ.)

OUTLINE DRAWING
SOP28-P-450-1.27

Unit : mm

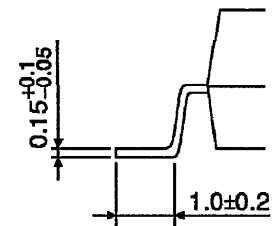
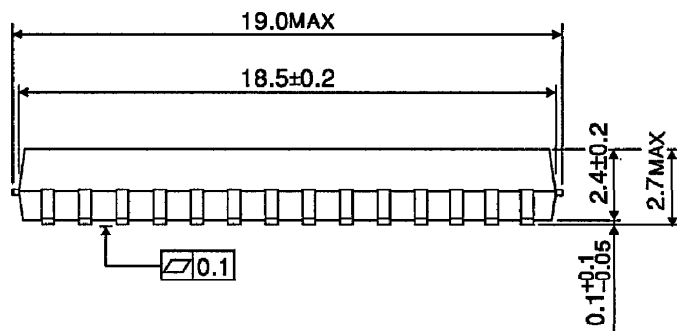
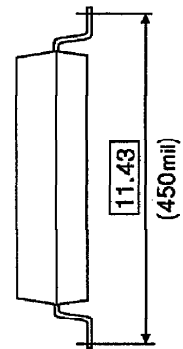
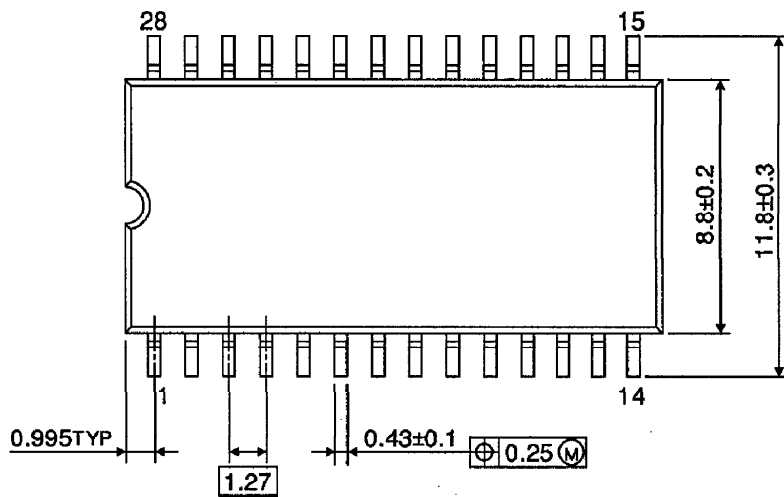

Weight : 0.8g (Typ.)

OUTLINE DRAWING
SDIP42-P-600-1.78

Unit : mm

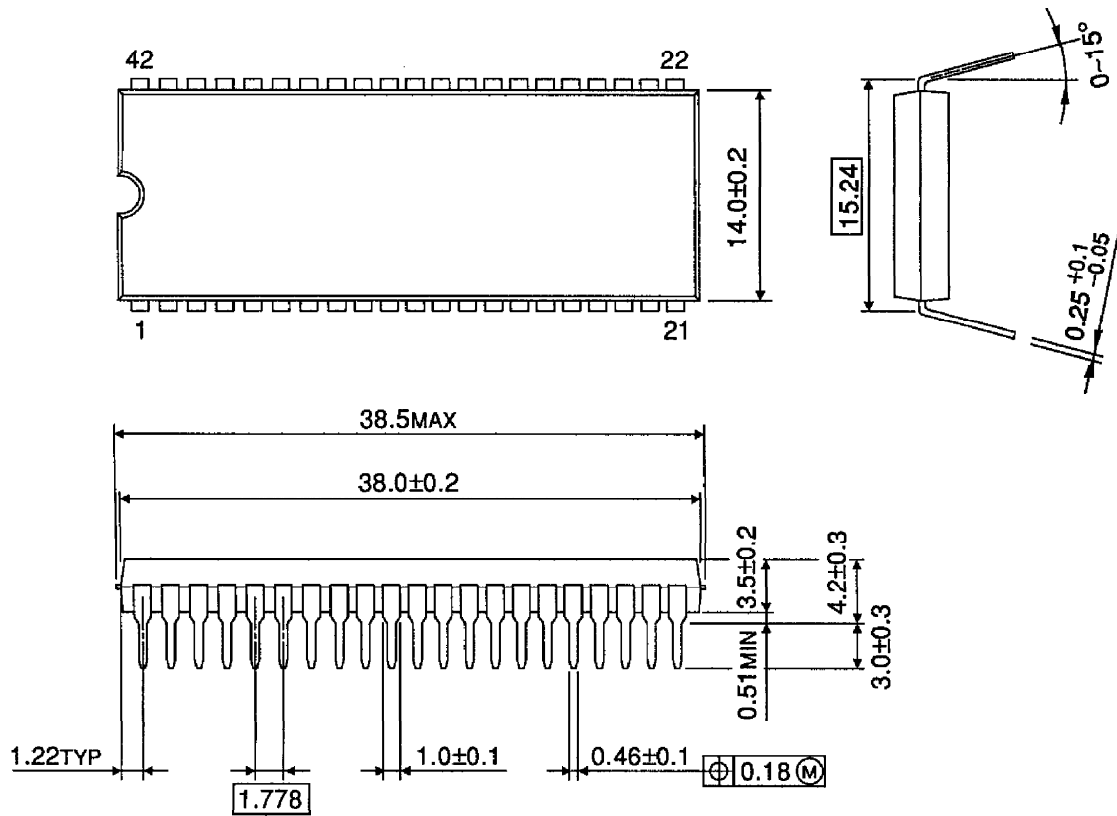

Weight : 4.2g (Typ.)

OUTLINE DRAWING
QFP44-P-1414-0.80D

Unit : mm

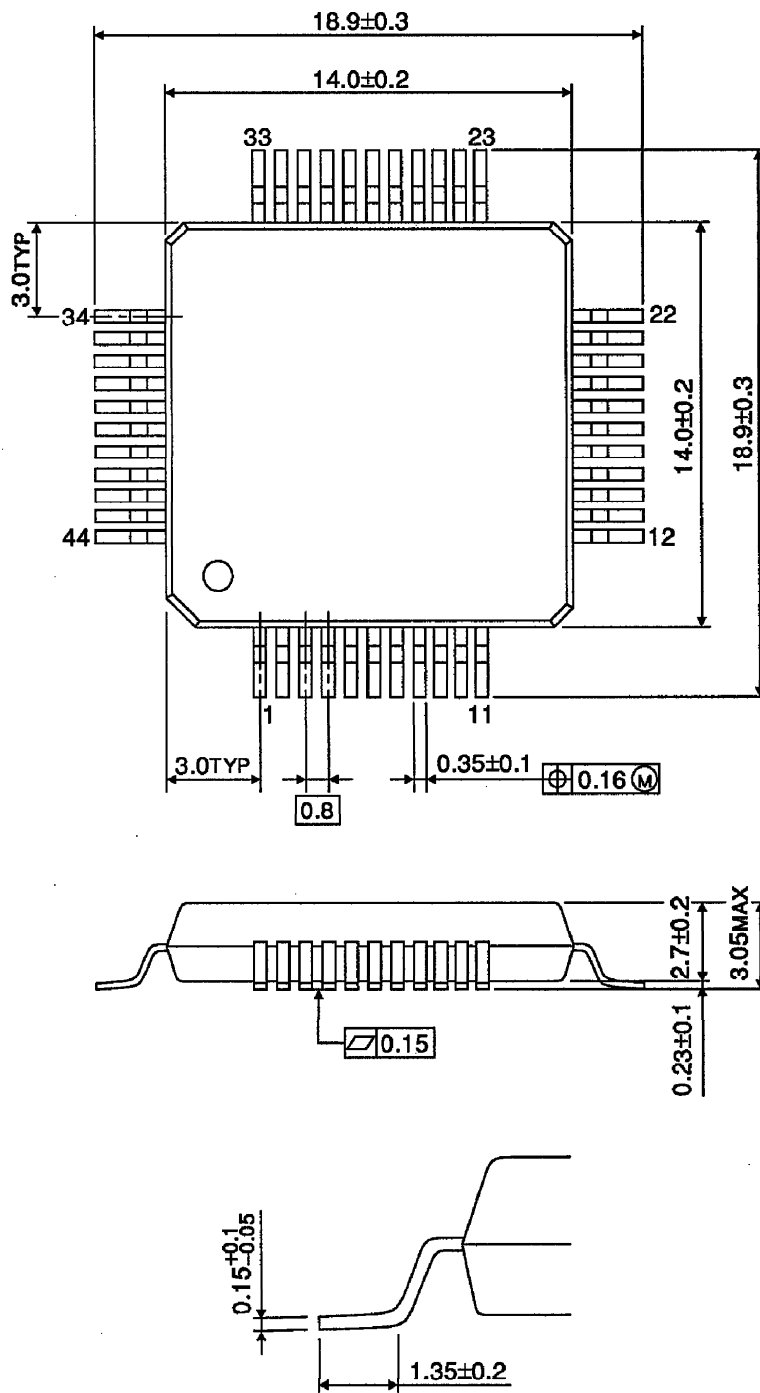

Weight : 1.1g (Typ.)