

TOSHIBA CMOS Digital Integrated Circuit Silicon Monolithic

TC74LVX4245FS

Dual Supply Octal Bus Transceiver

The TC74LVX4245FS is a dual supply, advanced high-speed CMOS octal bus transceiver fabricated with silicon gate CMOS technology.

Designed for use as an interface between a 5V bus and a 3.3V bus in mixed 5V/3.3V supply systems' it achieves high-speed operation while maintaining the CMOS low power dissipation.

It is intended for 2 way asynchronous communication between data busses. The direction of data transmission is determined by the level of the DIR input.

The enable input (\bar{G}) can be used to disable the device so that the busses are effectively isolated. The A-port interfaces with the 5V bus, the B-port with the 3.3V bus.

All inputs are equipped with protection circuits against static discharge or transient excess voltage.

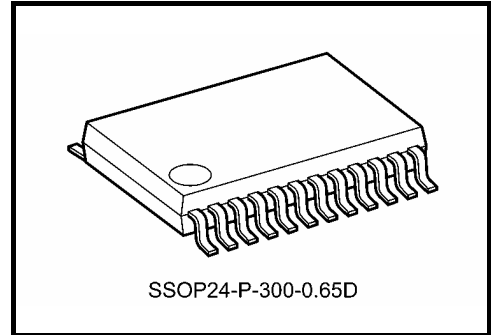

Weight: 0.14 g (typ.)

Features

- Bi-directional interface between 5 V and 3 V buses
- High-speed: $t_{pd} = 6.0$ ns (typ.)
($V_{CCA} = 5.0$ V, $V_{CCB} = 3.3$ V)
- Low power dissipation: $I_{CC} = 8$ μ A (max) ($T_a = 25^\circ$ C)
- Symmetrical output impedance: $I_{OUTA} = \pm 24$ mA (min)
 $I_{OUTB} = \pm 12$ mA (min)
($V_{CCA} = 4.5$ V, $V_{CCB} = 3.0$ V)
- Low noise: $V_{OLP} = 1.5$ V (max)
- Package: SSOP (shrink small outline package)

Note: Do not apply a signal to any bus pins when it is in the output mode. Damage may result.

All floating (high impedance) bus pin must have their input levels fixed by means of pull up or pull down resistors.

Pin Assignment (top view)

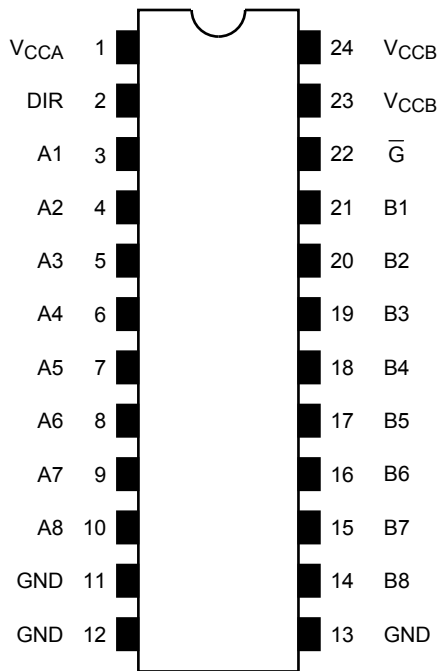

IEC Logic Symbol

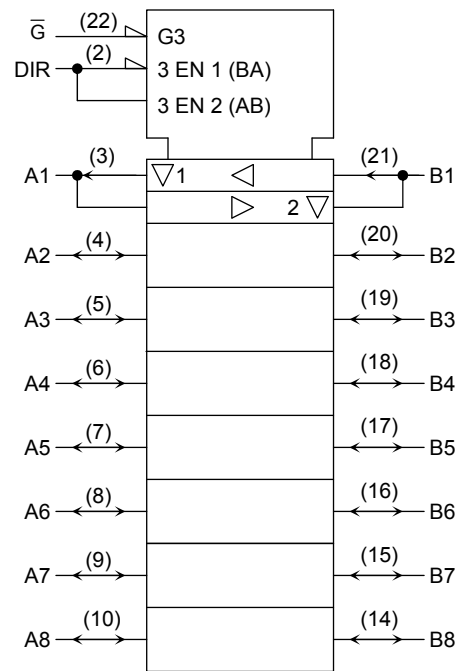

Truth Table

Inputs		Outputs	Function	
\bar{G}	DIR		A-Bus	B-Bus
L	L	A = B	Output	Input
L	H	B = A	Input	Output
H	X	Z	High impedance	

X: Don't care

Z: High impedance

Block Diagram

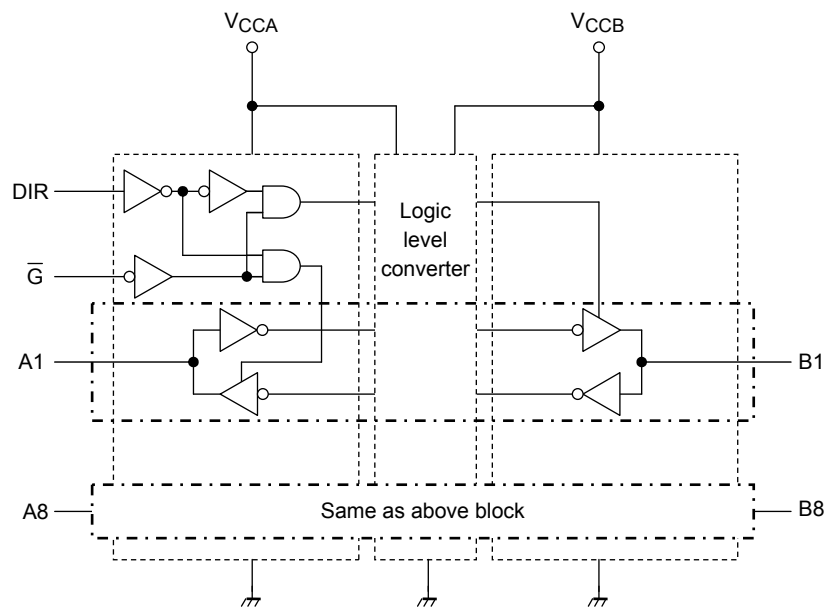

Absolute Maximum Ratings (Note 1)

Characteristics	Symbol	Rating	Unit
Supply voltage range (Note 2)	V_{CCA}	-0.5 to 7.0	V
	V_{CCB}	-0.5 to $V_{CCA} + 0.5$	
DC input voltage	V_{IN}	-0.5 to $V_{CCA} + 0.5$	V
DC bus I/O voltage	V_{IOA}	-0.5 to $V_{CCA} + 0.5$	V
	V_{IOB}	-0.5 to $V_{CCB} + 0.5$	
Input diode current	I_{IK}	-20	mA
Output diode current	$I_{I/OK}$	± 50	mA
DC output current	I_{OUTA}	± 50	mA
	I_{OUTB}	± 50	
DC V_{CC} /ground current	I_{CCA}	± 200	mA
	I_{CCB}	± 100	
Power dissipation	P_D	180	mW
Storage temperature	T_{stg}	-65 to 150	$^{\circ}C$

Note 1: Exceeding any of the absolute maximum ratings, even briefly, lead to deterioration in IC performance or even destruction.

Using continuously under heavy loads (e.g. the application of high temperature/current/voltage and the significant change in temperature, etc.) may cause this product to decrease in the reliability significantly even if the operating conditions (i.e. operating temperature/current/voltage, etc.) are within the absolute maximum ratings and the operating ranges.

Please design the appropriate reliability upon reviewing the Toshiba Semiconductor Reliability Handbook ("Handling Precautions"/"Derating Concept and Methods") and individual reliability data (i.e. reliability test report and estimated failure rate, etc).

Note 2: $V_{CCA} > V_{CCB}$

Don't use under the condition that V_{CCB} is 0 V.

Operating Ranges (Note)

Characteristics	Symbol	Rating	Unit
Supply voltage	V_{CCA}	4.5 to 5.5	V
	V_{CCB}	2.7 to 3.6	
Input voltage	V_{IN}	0 to V_{CCA}	V
Bus I/O voltage	$V_{I/OA}$	0 to V_{CCA}	V
	$V_{I/OB}$	0 to V_{CCB}	
Operating temperature	T_{opr}	-40 to 85	°C
Input rise and fall time	dt/dv	0 to 8 ($V_{CCA} = 4.5$ to 5.5 V)	ns/V
		0 to 8 ($V_{CCB} = 2.7$ to 3.6 V)	

Note: The operating ranges are required to ensure the normal operation of the device. Unused inputs and bus inputs must be tied to either VCC or GND. Please connect both bus inputs and the bus outputs with VCC or GND when the I/O of the bus terminal changes by the function. In this case, please note that the output is not short-circuited.

Electrical Characteristics

DC Characteristics ($V_{CCA} = 4.5$ to 5.5 V) ($V_{CCB} = 2.7$ to 3.6 V)

Characteristics	Symbol	Test Condition	V_{CCA} (V)	$T_a = 25^\circ\text{C}$			$T_a = -40$ to 85°C		Unit	
				Min	Typ.	Max	Min	Max		
Input voltage	H-level	V_{IHA}	DIR, \bar{G} , An	4.5 to 5.5	2.0	—	—	2.0	—	V
	L-level	V_{ILA}	DIR, \bar{G} , An	4.5 to 5.5	—	—	0.8	—	0.8	
Output voltage	H-level	V_{OHA}	$V_{INA} = V_{IHA}$ or V_{ILA} $I_{OH} = -100 \mu\text{A}$	4.5	4.4	4.5	—	4.4	—	V
			$V_{INB} = V_{IHB}$ or V_{ILB} $I_{OH} = -24 \text{ mA}$	4.5	3.86	—	—	3.76	—	
	L-level	V_{OLA}	$V_{INA} = V_{IHA}$ or V_{ILA} $I_{OL} = 100 \mu\text{A}$	4.5	—	0.0	0.1	—	0.1	
			$V_{INB} = V_{IHB}$ or V_{ILB} $I_{OL} = 24 \text{ mA}$	4.5	—	—	0.36	—	0.44	
3-state output Off-state current	I_{OZA}	$V_{INA} = V_{IHA}$ or V_{ILA} $V_{INB} = V_{IHB}$ or V_{ILB} $V_{I/OA} = V_{CCA}$ or GND	5.5	—	—	± 0.5	—	± 5.0	μA	
Input leakage current	I_{INA}	V_{IN} (DIR, \bar{G}) $= V_{CCA}$ or GND	5.5	—	—	± 0.1	—	± 1.0	μA	
Quiescent supply current	I_{CCA}	$V_{INA} = V_{CCA}$ or GND $V_{INB} = V_{CCB}$ or GND	5.5	—	—	8.0	—	80.0	μA	
	I_{CCTA}	$V_{INA} = 3.4$ V (per input) V_{CCA} or GND (other input)	5.5	—	—	2.3	—	2.5	mA	

DC Characteristics ($V_{CCB} = 2.7$ to 3.6 V) ($V_{CCA} = 4.5$ to 5.5 V)

Characteristics		Symbol	Test Condition		Ta = 25°C			Ta = -40 to 85°C		Unit	
					V _{CCB} (V)	Min	Typ.	Max	Min		Max
Input voltage	H-level	V _{IHB}	Bn	2.7	2.0	—	—	2.0	—	V	
				3.6	2.2	—	—	2.2	—		
	L-level	V _{ILB}	Bn	2.7	—	—	0.8	—	0.8		
				3.6	—	—	0.8	—	0.8		
Output voltage	H-level	V _{OHB}	V _{INA} = V _{IHA} or V _{ILA}	I _{OH} = -100 μA	3.0	2.9	3.0	—	2.9	—	V
				I _{OH} = -8 mA	2.7	2.26	—	—	2.20	—	
				I _{OH} = -12 mA	3.0	2.48	—	—	2.40	—	
	L-level	V _{OLB}	V _{INA} = V _{IHA} or V _{ILA}	I _{OL} = 100 μA	3.0	—	0.0	0.1	—	0.1	
				I _{OL} = 8 mA	2.7	—	—	0.31	—	0.40	
				I _{OL} = 12 mA	3.0	—	—	0.31	—	0.40	
3-state output Off-state current		I _{OZB}	V _{INA} = V _{IHA} or V _{ILA} V _{I/OB} = V _{CCB} or GND	3.6	—	—	±0.5	—	±5.0	μA	
Quiescent supply current		I _{CCB}	V _{INA} = V _{CCA} or GND V _{INB} = V _{CCB} or GND	3.6	—	—	5.0	—	50.0	μA	
		I _{CCTB}	V _{INA} = 3.0 V (per input) V _{CCB} or GND (other input)	3.6	—	—	0.35	—	0.50	mA	

AC Characteristics (input: $t_r = t_f = 3 \text{ ns}$, $C_L = 50 \text{ pF}$, $R_L = 500 \text{ } \Omega$, $V_{CCA} = 5.0 \pm 0.5 \text{ V}$)

Characteristics	Symbol	Test Condition	Ta = 25°C			Ta = -40 to 85°C		Unit	
			VCC (V)	Min	Typ.	Max	Min		Max
Propagation delay time (An ⇒ Bn)	t _{pLH}	Input: An Output: Bn (DIR = "H")	2.7	—	7.1	9.5	1.0	10.5	ns
	t _{pHL}		3.3 ± 0.3	—	6.5	8.6	1.0	9.5	
3-state output enable time (\bar{G} ⇒ Bn)	t _{pZL}		2.7	—	9.5	12.5	1.0	13.8	ns
	t _{pZH}		3.3 ± 0.3	—	8.6	11.4	1.0	12.5	
3-state output disable time (\bar{G} ⇒ Bn)	t _{pLZ}		2.7	—	5.3	9.1	1.0	10.0	ns
	t _{pHZ}		3.3 ± 0.3	—	5.3	9.1	1.0	10.0	
Propagation delay time (Bn ⇒ An)	t _{pLH}	Input: Bn Output: An (DIR = "L")	2.7	—	7.0	9.5	1.0	10.5	ns
	t _{pHL}		3.3 ± 0.3	—	6.4	8.6	1.0	9.5	
3-state output enable time (\bar{G} ⇒ An)	t _{pZL}		2.7	—	8.5	11.6	1.0	12.7	ns
	t _{pZH}		3.3 ± 0.3	—	7.7	10.5	1.0	11.5	
3-state output disable time (\bar{G} ⇒ An)	t _{pLZ}		2.7	—	5.1	6.8	1.0	7.5	ns
	t _{pHZ}		3.3 ± 0.3	—	5.1	6.8	1.0	7.5	
Output to output skew	t _{osLH}	(Note 1)	2.7	—	—	1.5	—	1.5	ns
	t _{osHL}		3.3 ± 0.3	—	—	1.5	—	1.5	
Input capacitance	C _{INA}	DIR, \bar{G}	3.3 ± 0.3	—	5	10	—	10	pF
Bus input capacitance	C _{I/O}	An, Bn	3.3 ± 0.3	—	13	—	—	—	pF
Power dissipation capacitance (Note 2)	C _{PD} A	A ⇒ B (DIR = "H")	3.3 ± 0.3	—	17	—	—	—	pF
		B ⇒ A (DIR = "L")	3.3 ± 0.3	—	25	—	—	—	
	C _{PD} B	A ⇒ B (DIR = "H")	3.3 ± 0.3	—	4	—	—	—	
		B ⇒ A (DIR = "L")	3.3 ± 0.3	—	4	—	—	—	

Note 1: Parameter guaranteed by design.

$$(t_{osLH} = |t_{pLHm} - t_{pLHn}|, t_{osHL} = |t_{pHLm} - t_{pHLn}|)$$

Note 2: C_{PD} is defined as the value of the internal equivalent capacitance which is calculated from the operating current consumption without load.

Average operating current can be obtained by the equation:

$$I_{CC(opr)} = C_{PD} \cdot V_{CC} \cdot f_{IN} + I_{CC}/8 \text{ (per bit)}$$

Noise Characteristics (Ta = 25°C, input: tr = tf = 3 ns, CL = 50 pF, RL = 500 Ω)

Characteristics	Symbol	Symbol	Test Condition	VCC (V)		Typ.	Limit	Unit
				VCCA (V)	VCCB (V)			
Quiet output maximum dynamic	VOL (A)	VOLPA	Input: Bn	5.0	3.3	1.0	1.5	V
Quiet output minimum dynamic	VOL (A)	VOLVA	Output: An (DIR = "L")	5.0	3.3	-0.6	-1.2	V
Quiet output maximum dynamic	VOL (B)	VOLPB	Input: An	5.0	3.3	0.8	1.2	V
Quiet output minimum dynamic	VOL (B)	VOLVB	Output: Bn (DIR = "H")	5.0	3.3	-0.5	-0.8	V
Minimum high level dynamic input voltage	VIH (A)	VIHDA	Input: An	5.0	3.3	—	2.0	V
Maximum low level dynamic input voltage	VIL (A)	VILD A	Input: An	5.0	3.3	—	0.8	V
Minimum high level dynamic input voltage	VIH (B)	VIHDB	Input: Bn	5.0	3.3	—	2.0	V
Maximum low level dynamic input voltage	VIL (B)	VILDB	Input: Bn	5.0	3.3	—	0.8	V

Package Dimensions

SSOP24-P-300-0.65D

Unit: mm

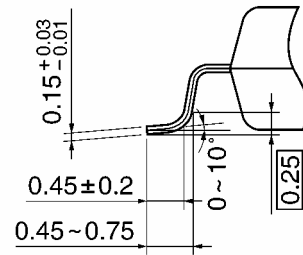
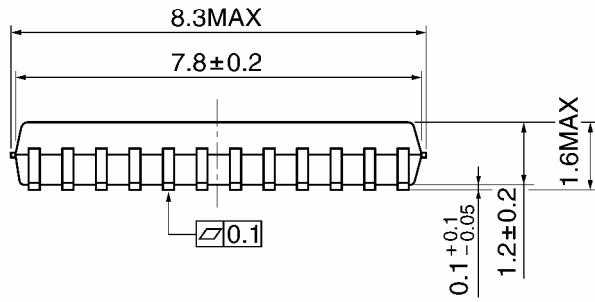
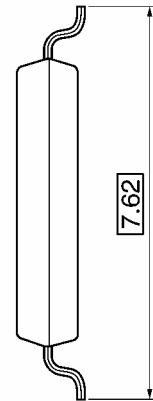
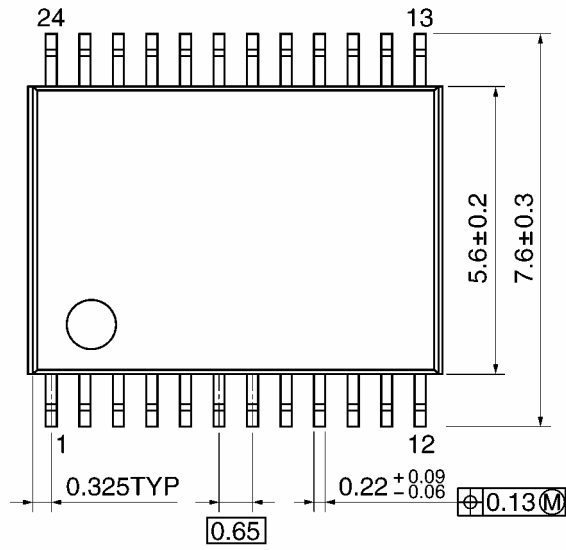

Weight: 0.14 g (typ.)

RESTRICTIONS ON PRODUCT USE

20070701-EN

- The information contained herein is subject to change without notice.
- TOSHIBA is continually working to improve the quality and reliability of its products. Nevertheless, semiconductor devices in general can malfunction or fail due to their inherent electrical sensitivity and vulnerability to physical stress. It is the responsibility of the buyer, when utilizing TOSHIBA products, to comply with the standards of safety in making a safe design for the entire system, and to avoid situations in which a malfunction or failure of such TOSHIBA products could cause loss of human life, bodily injury or damage to property.
In developing your designs, please ensure that TOSHIBA products are used within specified operating ranges as set forth in the most recent TOSHIBA products specifications. Also, please keep in mind the precautions and conditions set forth in the "Handling Guide for Semiconductor Devices," or "TOSHIBA Semiconductor Reliability Handbook" etc.
- The TOSHIBA products listed in this document are intended for usage in general electronics applications (computer, personal equipment, office equipment, measuring equipment, industrial robotics, domestic appliances, etc.). These TOSHIBA products are neither intended nor warranted for usage in equipment that requires extraordinarily high quality and/or reliability or a malfunction or failure of which may cause loss of human life or bodily injury ("Unintended Usage"). Unintended Usage include atomic energy control instruments, airplane or spaceship instruments, transportation instruments, traffic signal instruments, combustion control instruments, medical instruments, all types of safety devices, etc.. Unintended Usage of TOSHIBA products listed in this document shall be made at the customer's own risk.
- The products described in this document shall not be used or embedded to any downstream products of which manufacture, use and/or sale are prohibited under any applicable laws and regulations.
- Please contact your sales representative for product-by-product details in this document regarding RoHS compatibility. Please use these products in this document in compliance with all applicable laws and regulations that regulate the inclusion or use of controlled substances. Toshiba assumes no liability for damage or losses occurring as a result of noncompliance with applicable laws and regulations.