

TOSHIBA CMOS Digital Integrated Circuit Silicon Monolithic

TC74AC245P, TC74AC245F, TC74AC245FT TC74AC640P, TC74AC640F, TC74AC640FT

Octal Bus Transceiver

TC74AC245P/F/FT 3-State, Non-Inverting

TC74AC640P/F/FT 3-State, Inverting

The TC74AC245, 640 are advanced high speed CMOS OCTAL BUS TRANSCEIVERS fabricated with silicon gate and double-layer metal wiring C²MOS technology.

They achieve the high speed operation similar to equivalent Bipolar Schottky TTL while maintaining the CMOS low power dissipation.

They are intended for two-way asynchronous communication between data busses. The direction of data transmission is determined by the level of the DIR input.

The enable input (\bar{G}) can be used to disable the device so that the busses are effectively isolated.

All inputs are equipped with protection circuits against static discharge or transient excess voltage.

Features (Note 1)(Note 2)

- High speed: $t_{pd} = 3.9$ ns (typ.) at $V_{CC} = 5$ V
- Low power dissipation: $I_{CC} = 8$ μ A (max) at $T_a = 25^\circ$ C
- High noise immunity: $V_{NIH} = V_{NIL} = 28\%$ V_{CC} (min)
- Symmetrical output impedance:
 $|I_{OH}| = |I_{OL}| = 24$ mA (min)
 Capability of driving 50 Ω transmission lines.
- Balanced propagation delays: $t_{pLH} \approx t_{pHL}$
- Wide operating voltage range: V_{CC} (opr) = 2 V to 5.5 V
- Pin and function compatible with 74F245/640

Note 1: Do not apply a signal to any bus terminal when it is in the output mode. Damage may result.

Note 2: All floating (high impedance) bus terminals must have their input levels fixed by means of pull up or pull down resistors.

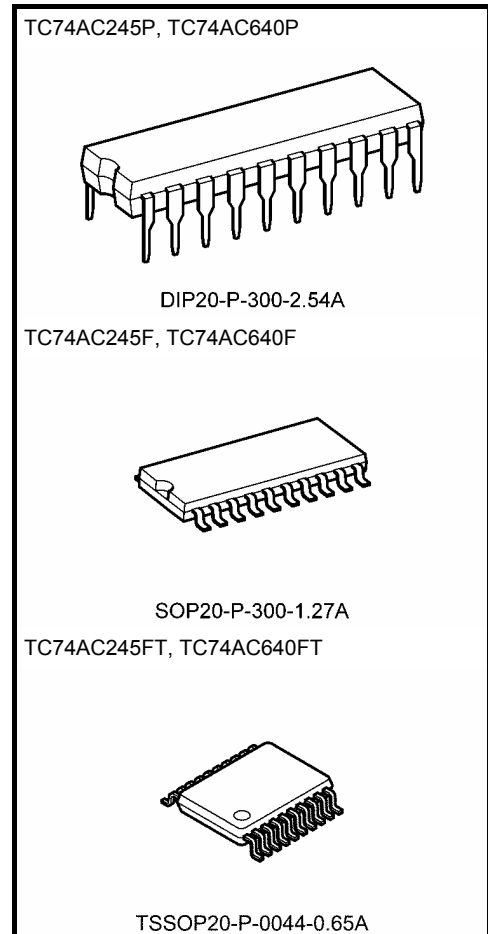

Weight

DIP20-P-300-2.54A	: 1.30 g (typ.)
SOP20-P-300-1.27A	: 0.22 g (typ.)
TSSOP20-P-0044-0.65A	: 0.08 g (typ.)

Pin Assignment

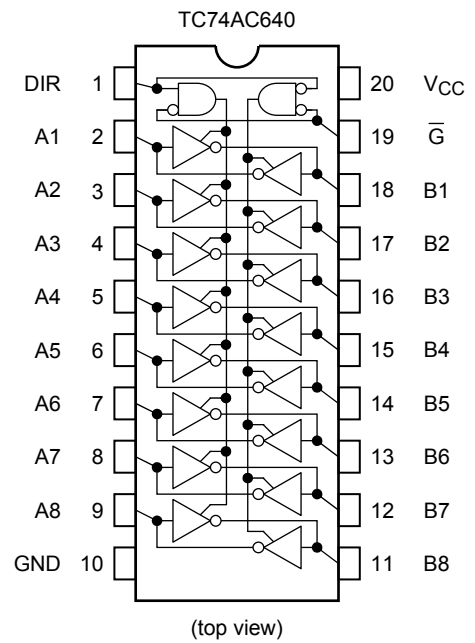
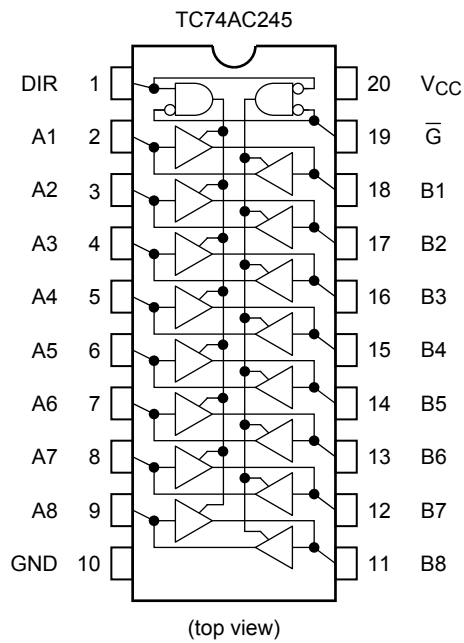

IEC Logic Symbol

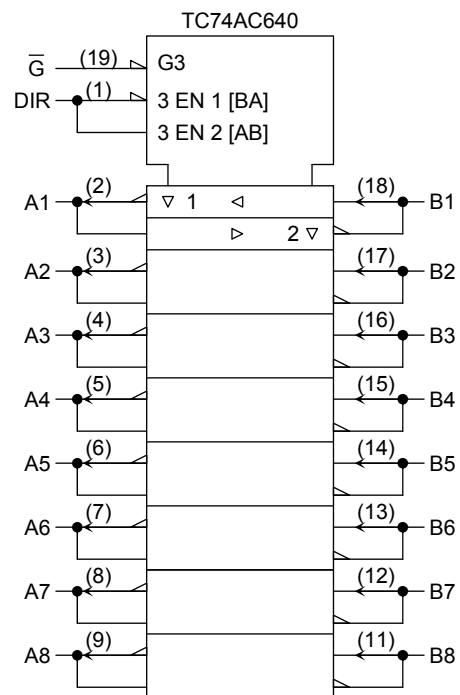
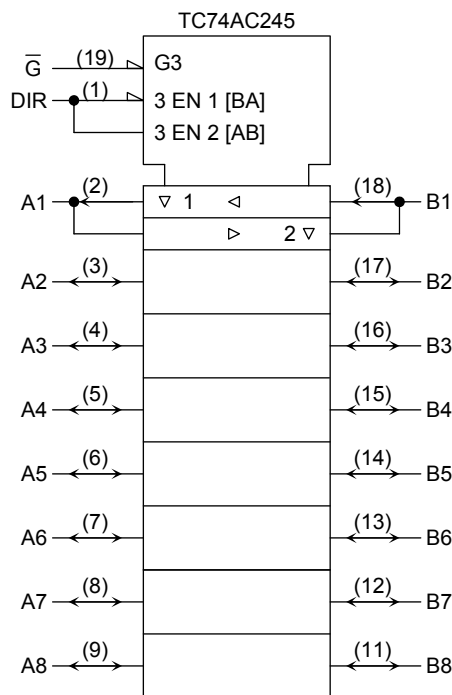

Truth Table

Inputs		Function		Outputs	
\bar{G}	DIR	A Bus	B Bus	AC245	AC640
L	L	Output	Input	A = B	A = \bar{B}
L	H	Input	Output	B = A	B = \bar{A}
H	X	Z		Z	Z

X: Don't care

Z: High impedance

Absolute Maximum Ratings (Note 1)

Characteristics	Symbol	Rating	Unit
Supply voltage range	V_{CC}	-0.5 to 7.0	V
DC input voltage	V_{IN}	-0.5 to $V_{CC} + 0.5$	V
DC output voltage	V_{OUT}	-0.5 to $V_{CC} + 0.5$	V
Input diode current	I_{IK}	± 20	mA
Output diode current	I_{OK}	± 50	mA
DC output current	I_{OUT}	± 50	mA
DC V_{CC} /ground current	I_{CC}	± 200	mA
Power dissipation	P_D	500 (DIP) (Note 2)/180 (SOP/TSSOP)	mW
Storage temperature	T_{stg}	-65 to 150	$^{\circ}C$

Note 1: Exceeding any of the absolute maximum ratings, even briefly, lead to deterioration in IC performance or even destruction.

Using continuously under heavy loads (e.g. the application of high temperature/current/voltage and the significant change in temperature, etc.) may cause this product to decrease in the reliability significantly even if the operating conditions (i.e. operating temperature/current/voltage, etc.) are within the absolute maximum ratings and the operating ranges.

Please design the appropriate reliability upon reviewing the Toshiba Semiconductor Reliability Handbook ("Handling Precautions"/Derating Concept and Methods) and individual reliability data (i.e. reliability test report and estimated failure rate, etc).

Note 2: 500 mW in the range of $T_a = -40^{\circ}C$ to $65^{\circ}C$. From $T_a = 65^{\circ}C$ to $85^{\circ}C$ a derating factor of -10 mW/ $^{\circ}C$ should be applied up to 300 mW.

Operating Ranges (Note)

Characteristics	Symbol	Rating	Unit
Supply voltage	V_{CC}	2.0 to 5.5	V
Input voltage	V_{IN}	0 to V_{CC}	V
Output voltage	V_{OUT}	0 to V_{CC}	V
Operating temperature	T_{opr}	-40 to 85	$^{\circ}C$
Input rise and fall time	dt/dV	0 to 100 ($V_{CC} = 3.3 \pm 0.3$ V) 0 to 20 ($V_{CC} = 5 \pm 0.5$ V)	ns/V

Note: The operating ranges are required to ensure the normal operation of the device. Unused inputs and bus inputs must be tied to either V_{CC} or GND. Please connect both bus inputs and the bus outputs with V_{CC} or GND when the I/O of the bus terminal changes by the function. In this case, please note that the output is not short-circuited.

Electrical Characteristics

DC Characteristics

Characteristics	Symbol	Test Condition		Ta = 25°C			Ta = -40 to 85°C		Unit	
				V _{CC} (V)	Min	Typ.	Max	Min		Max
High-level input voltage	V _{IH}	—		2.0	1.50	—	—	1.50	—	V
				3.0	2.10	—	—	2.10	—	
				5.5	3.85	—	—	3.85	—	
Low-level input voltage	V _{IL}	—		2.0	—	—	0.50	—	0.50	V
				3.0	—	—	0.90	—	0.90	
				5.5	—	—	1.65	—	1.65	
High-level output voltage	V _{OH}	V _{IN} = V _{IH} or V _{IL}	I _{OH} = -50 μA	2.0	1.9	2.0	—	1.9	—	V
				3.0	2.9	3.0	—	2.9	—	
			I _{OH} = -4 mA	3.0	2.58	—	—	2.48	—	
			I _{OH} = -24 mA	4.5	3.94	—	—	3.80	—	
		I _{OH} = -75 mA (Note)	5.5	—	—	—	3.85	—		
Low-level output voltage	V _{OL}	V _{IN} = V _{IH} or V _{IL}	I _{OL} = 50 μA	2.0	—	0.0	0.1	—	0.1	V
				3.0	—	0.0	0.1	—	0.1	
				4.5	—	0.0	0.1	—	0.1	
			I _{OL} = 12 mA	3.0	—	—	0.36	—	0.44	
			I _{OL} = 24 mA	4.5	—	—	0.36	—	0.44	
		I _{OL} = 75 mA (Note)	5.5	—	—	—	—	1.65		
3-state output off-state current	I _{OZ}	V _{IN} = V _{IH} or V _{IL} V _{OUT} = V _{CC} or GND	5.5	—	—	±0.5	—	±5.0	μA	
Input leakage current	I _{IN}	V _{IN} = V _{CC} or GND	5.5	—	—	±0.1	—	±1.0	μA	
Quiescent supply current	I _{CC}	V _{IN} = V _{CC} or GND	5.5	—	—	8.0	—	80.0	μA	

Note: This spec indicates the capability of driving 50 Ω transmission lines.

One output should be tested at a time for a 10 ms maximum duration.

AC Characteristics ($C_L = 50 \text{ pF}$, $R_L = 500 \Omega$, input: $t_r = t_f = 3 \text{ ns}$)

Characteristics	Symbol	Test Condition	Ta = 25°C			Ta = -40 to 85°C		Unit	
			V _{CC} (V)	Min	Typ.	Max	Min		Max
Propagation delay time (Note 2)	t _{pLH}	—	3.3 ± 0.3	—	7.0	10.9	1.0	12.4	ns
	t _{pHL}		5.0 ± 0.5	—	5.0	7.5	1.0	8.5	
Propagation delay time (Note 3)	t _{pLH}	—	3.3 ± 0.3	—	6.4	10.0	1.0	11.4	ns
	t _{pHL}		5.0 ± 0.5	—	4.8	7.0	1.0	8.0	
Output enable time	t _{pZL}	—	3.3 ± 0.3	—	9.3	15.3	1.0	17.4	ns
	t _{pZH}		5.0 ± 0.5	—	7.1	10.5	1.0	12.0	
Output disable time	t _{pLZ}	—	3.3 ± 0.3	—	7.1	11.4	1.0	13.0	ns
	t _{pHZ}		5.0 ± 0.5	—	5.9	8.7	1.0	10.0	
Input capacitance	C _{IN}	DIR, \bar{G}	—	5	10	—	10	pF	
Bus input capacitance	C _{I/O}	A _n , B _n	—	13	—	—	—	pF	
Power dissipation capacitance (Note 1)	C _{PD}	TC74AC245	—	38	—	—	—	pF	
		TC74AC640	—	36	—	—	—		

Note 1: C_{PD} is defined as the value of the internal equivalent capacitance which is calculated from the operating current consumption without load.

Average operating current can be obtained by the equation:

$$I_{CC (opr)} = C_{PD} \cdot V_{CC} \cdot f_{IN} \cdot I_{CC} / 8 \text{ (per bit)}$$

Note 2: For TC74AC245 only

Note 3: For TC74AC640 only

Package Dimensions

DIP20-P-300-2.54A

Unit : mm

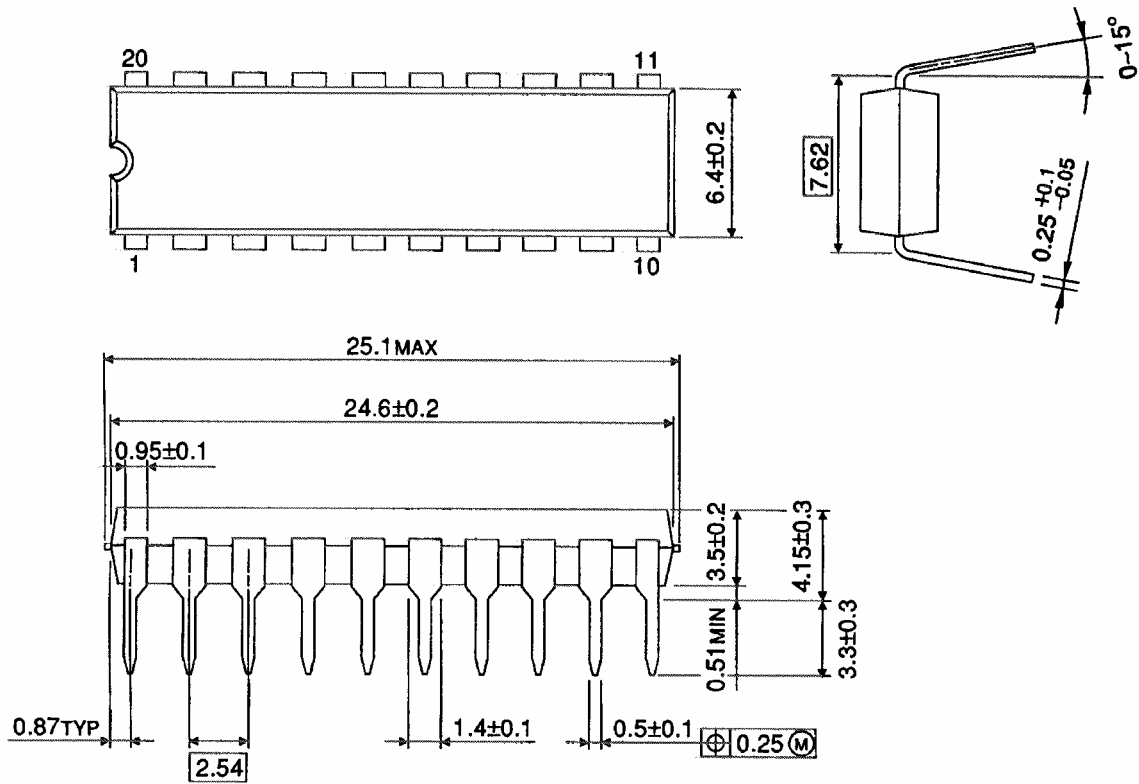

Weight: 1.30 g (typ.)

Package Dimensions

SOP20-P-300-1.27A

Unit: mm



Weight: 0.22 g (typ.)

Package Dimensions

TSSOP20-P-0044-0.65A

Unit: mm

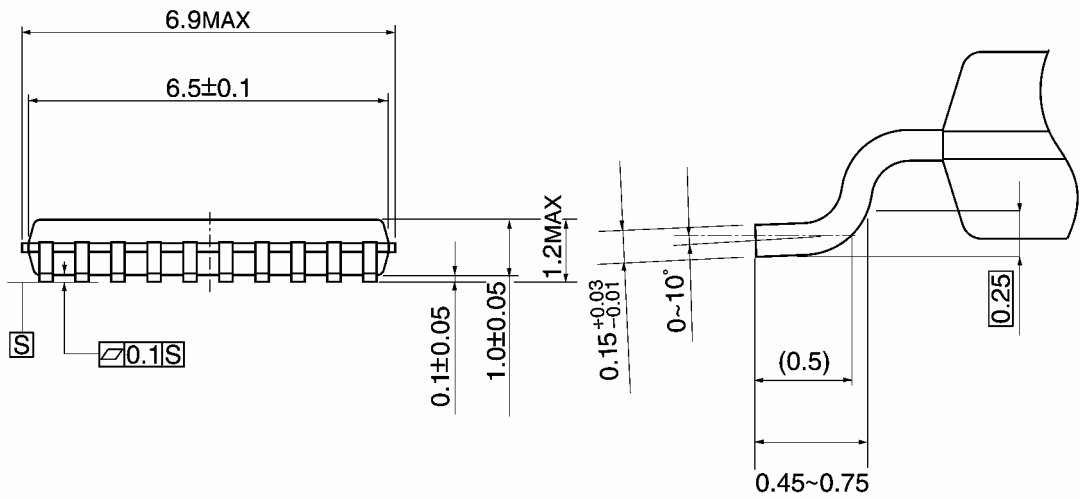
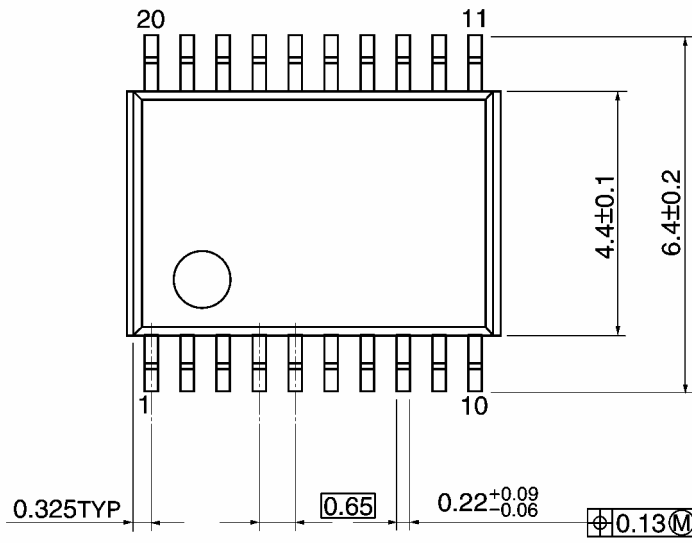

Weight: 0.08 g (typ.)

RESTRICTIONS ON PRODUCT USE

20070701-EN

- The information contained herein is subject to change without notice.
- TOSHIBA is continually working to improve the quality and reliability of its products. Nevertheless, semiconductor devices in general can malfunction or fail due to their inherent electrical sensitivity and vulnerability to physical stress. It is the responsibility of the buyer, when utilizing TOSHIBA products, to comply with the standards of safety in making a safe design for the entire system, and to avoid situations in which a malfunction or failure of such TOSHIBA products could cause loss of human life, bodily injury or damage to property.
In developing your designs, please ensure that TOSHIBA products are used within specified operating ranges as set forth in the most recent TOSHIBA products specifications. Also, please keep in mind the precautions and conditions set forth in the "Handling Guide for Semiconductor Devices," or "TOSHIBA Semiconductor Reliability Handbook" etc.
- The TOSHIBA products listed in this document are intended for usage in general electronics applications (computer, personal equipment, office equipment, measuring equipment, industrial robotics, domestic appliances, etc.). These TOSHIBA products are neither intended nor warranted for usage in equipment that requires extraordinarily high quality and/or reliability or a malfunction or failure of which may cause loss of human life or bodily injury ("Unintended Usage"). Unintended Usage include atomic energy control instruments, airplane or spaceship instruments, transportation instruments, traffic signal instruments, combustion control instruments, medical instruments, all types of safety devices, etc.. Unintended Usage of TOSHIBA products listed in this document shall be made at the customer's own risk.
- The products described in this document shall not be used or embedded to any downstream products of which manufacture, use and/or sale are prohibited under any applicable laws and regulations.
- Please contact your sales representative for product-by-product details in this document regarding RoHS compatibility. Please use these products in this document in compliance with all applicable laws and regulations that regulate the inclusion or use of controlled substances. Toshiba assumes no liability for damage or losses occurring as a result of noncompliance with applicable laws and regulations.