

## Integrated Temperature Sensor & Brushless DC Fan Controller with FanSense™ Detect & Over-Temperature

### Features

- Integrated Temperature Sensing and Multi-speed Fan Control
- FanSense™ Fan Fault Detect Circuitry
- Built-in Over-Temperature Alert ( $T_{\text{OVER}}$ )
- Temperature Proportional Fan Speed Control for Acoustic Noise Reduction and Longer Fan Life
- Pulse Width Modulation Output Drive for Cost and Power Savings
- Solid-State Temperature Sensing
- $\pm 1^{\circ}\text{C}$  (Typical) Accuracy from  $25^{\circ}\text{C}$  to  $+70^{\circ}\text{C}$
- 2.8V – 5.5V Operating Range
- TC653 includes Auto Fan Shutdown
- Low Operating Current: 50 $\mu\text{A}$  (Typical)

### Applications

- Thermal Protection For Personal Computers
- Digital Set-Top Boxes
- Notebook Computers
- Data Communications
- Power Supplies
- Projectors

### Related Literature

- Application Note: AN771

### Device Selection Table

Part Number	Package	Temperature Range
TC652XXVUA	8-Pin MSOP	-40°C to +125°C
TC653XXVUA	8-Pin MSOP	-40°C to +125°C

X	Temperature
A	25
B	30
C	35
D	40
E	45
F	50
G	55

The "X" denotes a suffix for temperature threshold settings. Contact factory for other temperature ranges.

### Package Type

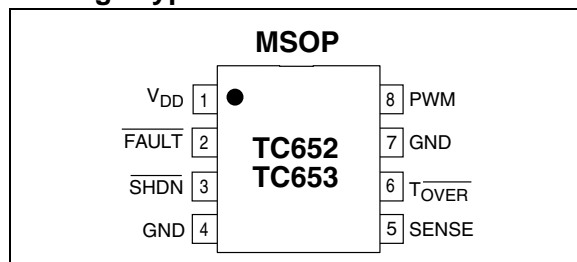

### General Description

The TC652/TC653 are integrated temperature sensors and brushless DC fan speed controllers with FanSense™ technology. The TC652/TC653 measure their junction temperature and control the speed of the fan based on that temperature, making them especially suited for applications in modern electronic equipment. The FanSense™ Fan Fault detect circuitry eliminates the need for a more expensive 3-wire fan.

Temperature data is converted from the on-chip thermal sensing element and translated into a fractional fan speed from 40% to 100%. A temperature selection guide in the data sheet is used to choose the low and high temperature limits to control the fan. The TC652/TC653 also include a single trip point over temperature alert ( $T_{\text{OVER}}$ ) that eliminates the need for additional temperature sensors. In addition, the TC653 includes an auto fan shutdown function for additional power savings.

The TC652/TC653 are easy to use, require no software overhead and are therefore the ideal choice for implementing thermal management in a variety of systems.

# TC652/TC653

## Typical Application Diagram

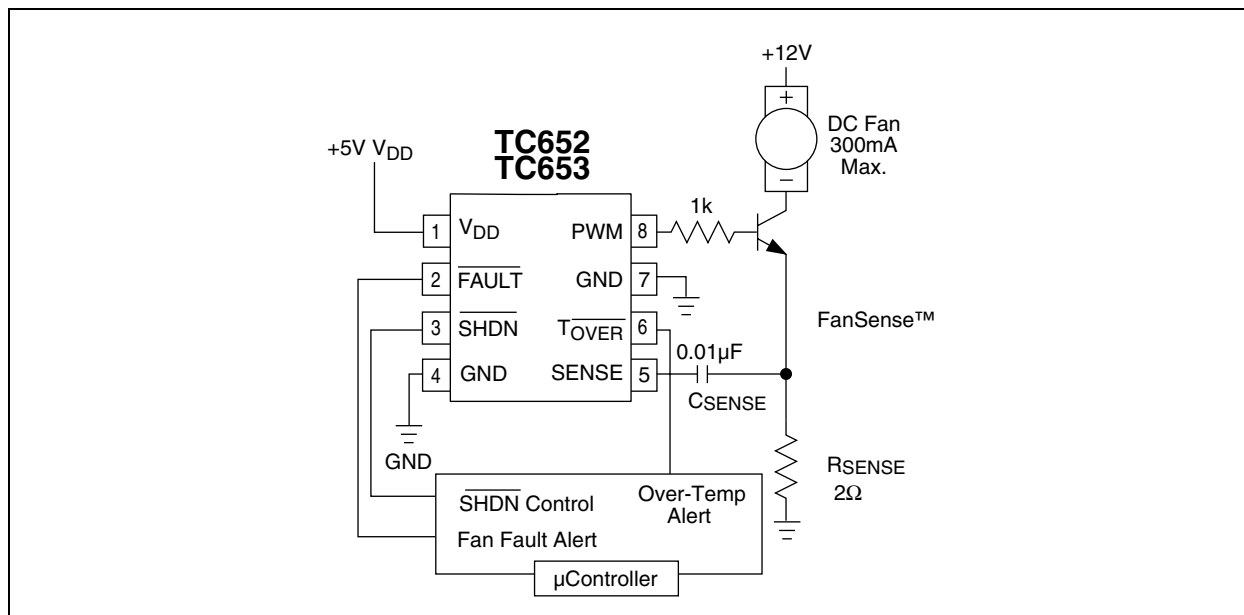

## 1.0 ELECTRICAL CHARACTERISTICS

### Absolute Maximum Ratings\*

Input Voltage ( $V_{DD}$ to GND) .....	+6V
Output Voltage (OUT to GND) .....	6V
Voltage On Any Pin .....	(GND - 0.3V) to ( $V_{DD}$ + 0.3V)
Package Thermal Resistance ( $\theta_{JA}$ ) .....	250°C/W
Operating Temperature Range .....	-40°C to +125°C
Storage Temperature .....	-65°C to +150°C

\*Stresses above those listed under "Absolute Maximum Ratings" may cause permanent damage to the device. These are stress ratings only and functional operation of the device at these or any other conditions above those indicated in the operation sections of the specifications is not implied. Exposure to Absolute Maximum Rating conditions for extended periods may affect device reliability.

### TC652/TC653 ELECTRICAL SPECIFICATIONS

Electrical Characteristics: $V_{DD} = 2.8V$ to $5.5V$ , $\overline{SHDN} = V_{DD}$ , $T_A = -40^\circ C$ to $125^\circ C$ unless otherwise specified.						
Symbol	Parameter	Min	Typ.	Max	Units	Test Conditions
$V_{DD}$	Supply Voltage	2.8	—	5.5	V	
$I_{DD}$	Supply Current	—	50	90	$\mu A$	PWM, $\overline{FAULT}$ , $T_{OVER}$ are open
<b><math>\overline{SHDN}</math> Input</b>						
$V_{IH}$	$\overline{SHDN}$ Input High Threshold	65	—	—	% $V_{DD}$	
$V_{IL}$	$\overline{SHDN}$ Input Low Threshold	—	—	15	% $V_{DD}$	
<b>PWM Output</b>						
$V_{OL}$	PWM Output Low Voltage	—	—	0.3	V	$I_{SINK} = 1mA$
$V_{OH}$	PWM Output High Voltage	$V_{DD} - 0.5$	—	—	V	$I_{SOURCE} = 5mA$
$t_R$	PWM Rise Time	—	10	—	$\mu sec$	$I_{OH} = 5mA$ , 1nF from PWM to GND
$t_F$	PWM Fall Time	—	10	—	$\mu sec$	$I_{OL} = 1mA$ , 1nF from PWM to GND
$f_{OUT}$	PWM Frequency	10	15	—	Hz	
$t_{STARTUP}$	Start-up Time	—	$32/f_{OUT}$	—	sec	$V_{DD}$ Rises from GND, or $\overline{SHDN}$ Released
$V_{TH(SENSE)}$	Sense Input	—	70	—	mV	Sense Input Threshold Voltage with Respect to Ground
<b>Temperature Accuracy</b>						
$T_{H ACC}$	High Temperature Accuracy	$T_H - 3$	$T_H$	$T_H + 3$	$^\circ C$	<b>Note 1</b>
$(T_H - T_L)_{ACC}$	Temp. Range Accuracy	-1.0	—	+1.0	$^\circ C$	$(T_H - T_L) \leq 20^\circ C$
		-2.5	—	+2.5	$^\circ C$	$(T_H - T_L) \geq 20^\circ C$
$T_{HYST}$	Auto-shutdown Hysteresis	—	$(T_H - T_L)/5$	—	$^\circ C$	TC653 Only
<b><math>\overline{FAULT}</math> Output</b>						
$V_{HIGH}$	$\overline{FAULT}$ Output High Voltage	$V_{DD} - 0.5$	—	—	V	$I_{SOURCE} = 1.2mA$
$V_{LOW}$	$\overline{FAULT}$ Output Low Voltage	—	—	0.4	V	$I_{SINK} = 2.5mA$
tmp	Missing Pulse Detector Time-out	—	—	$32/f_{OUT}$	Sec	
<b><math>T_{OVER}</math> Output</b>						
$V_{HIGH}$	$T_{OVER}$ Output High Voltage	$V_{DD} - 0.5$	—	—	V	$I_{SOURCE} = 1.2mA$
$V_{LOW}$	$T_{OVER}$ Output Low Voltage	—	—	0.4	V	$I_{SINK} = 2.5mA$
$T_{OVER ACC}$	Absolute Accuracy	—	$T_H + 10$	—	$^\circ C$	At Trip Point
$T_{OVER HYST}$	Trip Point Hysteresis	—	5	—	$^\circ C$	

**Note 1:** Transition from 90% to 100% Duty Cycle.

# TC652/TC653

---

## 2.0 PIN DESCRIPTIONS

The descriptions of the pins are listed in Table 2-1.

**TABLE 2-1: PIN FUNCTION TABLE**

Pin No. (8-Pin MSOP)	Symbol	Description
1	$V_{DD}$	Power Supply Input. May be independent of fan power supply.
2	$\overline{FAULT}$	Fan Fault Alert, Active-Low Output. FAULT goes low to indicate a fan FAULT condition. When $\overline{FAULT}$ occurs, the device is latched in Shutdown mode with PWM low. Toggling the SHDN pin or cycling the $V_{DD}$ will release the part and fan from shutdown. FAULT will unconditionally remain high during shutdown.
3	$\overline{SHDN}$	Fan Shutdown, Active-Low Input. During Shutdown mode the chip still monitors temperature and $\overline{T_{OVER}}$ is low if temperature rises above factory set point.
4	GND	Ground return for all TC652/TC653 functions.
5	SENSE	Detect Fan Pulses Input. Pulses are detected at this pin as fan rotation chops the current through the sense resistor, $R_{SENSE}$ . The absence of pulses indicates a Fan Fault.
6	$\overline{T_{OVER}}$	Over-Temperature Alert, Active-Low Output.
7	GND	Ground.
8	PWM	PWM Fan Drive Output. Pulse width modulated rail-to-rail logic output. Nominal Frequency is 15Hz.

## 3.0 DETAILED DESCRIPTION

The TC652/TC653 acquire and convert their junction temperature ( $T_J$ ) information from an on-chip solid state sensor with a typical accuracy of  $\pm 1^\circ\text{C}$ . The temperature data is digitally stored in an internal register. The register is compared with pre-defined threshold values. The six threshold values are equally distributed over a pre-defined range of temperatures (See Table 3-1 and Table 3-2). The TC652/TC653 control the speed of a DC brushless fan using a fractional speed control scheme. The output stage requires only a 2N2222-type small-signal BJT for fans up to 300mA. For larger current fans (up to 1 Amp) a logic-level N-channel MOSFET may be used. In addition to controlling the speed of the fan, the TC652/TC653 include an on-chip over-temperature alarm ( $T_{\text{OVER}}$ ) that gives a low-true signal when the temperature of the chip exceeds  $T_H$  by  $10^\circ\text{C}$ . This feature eliminates the need for a separate temperature sensor for over-temperature monitoring.

In normal fan operation, a pulse-train is present at SENSE, Pin 5. A Missing Pulse Detector monitors this pin during fan operation (FanSense™ technology). A stalled, open, or unconnected fan causes the TC652/TC653 to trigger its Start-up Timer once. If the FAULT persists, the FAULT output goes low, and the device is latched in its Shutdown mode. To release the fan from shutdown, toggle the SHDN or  $V_{\text{DD}}$  pin.

**TABLE 3-1: TEMPERATURE RANGE DEFINITION FOR TC652 (MINIMUM-SPEED MODE)**

Temperature ( $T = T_J$ )	PWM Duty Cycle
$T < T_L$	40%
$T_L \leq T < T_1$	50%
$T_1 \leq T < T_2$	60%
$T_2 \leq T < T_3$	70%
$T_3 \leq T < T_4$	80%
$T_4 \leq T < T_H$	90%
$T_H \leq T < T_{\text{OV}}$	100%
$T_{\text{OV}} \leq T$	100% with Over-Temp Alert ( $T_{\text{OVER}} = L$ )

**TABLE 3-2: TEMPERATURE RANGE DEFINITION FOR TC653 (AUTO-SHUTDOWN MODE)**

Temperature ( $T = T_J$ )	PWM Duty Cycle
$T < T_L$	"OFF"
$T_L \leq T < T_1$	50%
$T_1 \leq T < T_2$	60%
$T_2 \leq T < T_3$	70%
$T_3 \leq T < T_4$	80%
$T_4 \leq T < T_H$	90%
$T_H \leq T < T_{\text{OV}}$	100%
$T_{\text{OV}} \leq T$	100% with Over-Temp Alert ( $T_{\text{OVER}} = L$ )

**Note:** The temperature regions defined by the six temperature thresholds are pre-defined in the TC650/651 by means of trimming. Once a  $T_L$  and  $T_H$  are programmed, the  $T_1 - T_4$  thresholds are automatically equally spaced between  $T_L$  and  $T_H$ .

**FIGURE 3-1: FUNCTIONAL BLOCK DIAGRAM**

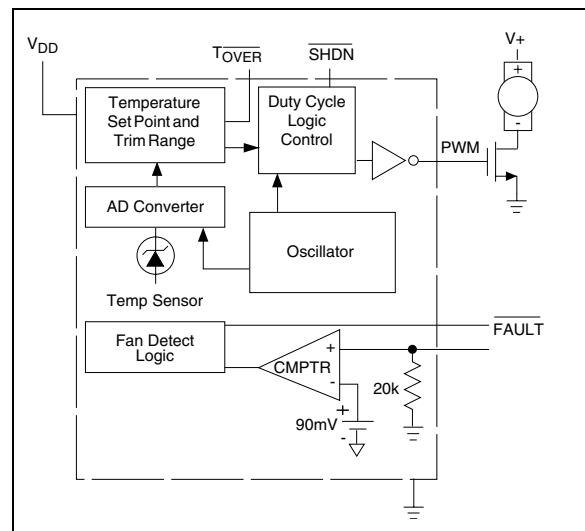

### 3.1 PWM Output

The PWM pin is designed to drive a low cost transistor or MOSFET as the low side power switching element in the system. This output has an asymmetric complementary drive and is optimized for driving NPN transistors or N-channel MOSFETs. Since the system relies on PWM rather than linear power control, the dissipation in the power switch is kept to a minimum. Generally, very small devices (TO-92 or SOT packages) will suffice. The frequency of the PWM is about 15Hz. The PWM is also the time base for the Start-up Timer (see paragraphs below). The PWM duty cycle has a range of 40% to 100% for the TC652 and 50% to 100% for the TC653.

## 3.2 Start-Up Timer

To ensure reliable fan start-up, the Start-up Timer turns PWM high for about 2 seconds whenever the fan is started from the off state. This occurs at power-up and when coming out of Shutdown mode.

## 3.3 SENSE Input (FanSense™ Technology)

The SENSE input, Pin 5, is connected to a low value current sensing resistor in the ground return leg of the fan circuit through the capacitor. During normal fan operation, commutation occurs as each pole of the fan is energized. This causes brief interruptions in the fan current, seen as pulses across the sense resistor. If the device is not in Shutdown mode, and pulses are not appearing at the SENSE input, a FAULT exists. The short, rapid change in fan current (high di/dt) causes a corresponding dv/dt across the sense resistor,  $R_{SENSE}$ . The waveform on  $R_{SENSE}$  is differentiated and converted to a logic-level pulse-train by  $C_{SENSE}$  and the internal signal processing circuitry. The presence and frequency of this pulse-train is a direct indication of fan operation.

## 3.4 FAULT

This pin goes low to indicate a fan FAULT condition. Pulses appearing at SENSE pin due to the PWM turning on are blanked and the remaining pulses are filtered by a Missing Pulse Detector. If consecutive pulses are not detected for 32 PWM cycles (about 2 sec), the PWM is Low and FAULT goes low. FAULT can be disabled by momentarily toggling SHDN or  $V_{DD}$  pin, or cycling system power. FAULT remains high during Shutdown mode.

## 3.5 Over-Temperature Alert ( $T_{OVER}$ )

This pin goes low when the  $T_H$  set point is exceeded by 10°C (typical). This indicates that the fan is at maximum drive, and the potential exists for system overheating: either heat dissipation in the system has gone beyond the cooling system's design limits, or some FAULT exists such as fan bearing failure or an airflow obstruction. This output may be treated as a "System Overheat" warning and used to trigger system shutdown, or bring other fans to full speed in the system. The fan will continue to run at 100% speed while  $T_{OVER}$  is asserted. Built-in hysteresis prevents  $T_{OVER}$  from "chattering" when measured temperature is at or near the  $T_H + 10^\circ\text{C}$  trip point. As temperature falls through the  $T_H + 10^\circ\text{C}$  trip point, hysteresis maintains the  $T_{OVER}$  output low until measured temperature is 5°C above the trip point setting.

## 3.6 Shutdown (SHDN)

The fan can be unconditionally shutdown by pulling low the SHDN pin. During shutdown, FAULT output is high and PWM output is low. This is ideal for notebook computers and other portable applications when you need to change batteries and must not have the fan running at that time. Thermal monitoring and  $T_{OVER}$  are still in operation during shutdown.  $I_{DD}$  shutdown current is around 50µA.

## 3.7 Auto-Shutdown Mode

The TC653 has auto-shutdown. If the temperature is below the factory set point at minimum speed ( $T_L$ ), PWM is low and the fan is automatically shut off (Auto-shutdown mode). This feature is ideal for notebook computers and other portable applications that need to conserve as much battery power as possible and thus run a fan when it is only absolutely needed. The TC653 will continue to be active so as to monitor temperature for  $T_{OVER}$ . The TC653 exits Auto-shutdown mode when the temperature rises above the factory set point ( $T_1$ ).

## 3.8 Temperature Selection Guide (Minimum Fan Speed/Full Speed)

The five temperature regions defined by the six thresholds are defined in the TC652/TC653 by means of factory trimming. Once a  $T_L$  and  $T_H$  are set, the  $T_1 - T_4$  thresholds are automatically equally spaced between  $T_L$  and  $T_H$ .

**TABLE 3-3: TEMPERATURE SELECTION GUIDE**

Temp. Range °C	T <sub>L</sub>	T <sub>H</sub>	Part #
10°C	25	35	AC
	30	40	BD
	35	45	CE
15°C	25	40	AD
	30	45	BE
	35	55	CG
20°C	<b>25</b>	<b>45</b>	AE
	30	50	BF
	35	55	CG
30°C	25	55	AG

**Note:** The **Bold Type** temperature settings are available for ordering. Contact factory for other temperature selections.

T<sub>L</sub> and T<sub>H</sub> can be selected in 5°C increments. T<sub>H</sub> must be chosen at least 10°C higher than T<sub>L</sub>. T<sub>L</sub> can range anywhere from 25°C to 35°C.

As an example, suppose you wanted the fan to **run at 40% speed at 25°C** or less and go to **full speed at 45°C**. You would order the part number TC652AEVUA.

As another example, suppose you wanted the fan to **turn on at 30°C** and go to **full speed at 45°C**. You would order the part number TC653BEVUA.

## 4.0 TYPICAL APPLICATIONS

### 4.1 Reducing Switching Noise

For fans consuming more than 300mA, a slowdown capacitor (C<sub>SLOW</sub>) is recommended for reducing switching PWM induced noise (see Figure 4-1). The value of this capacitor should be 4.7µF to 47µF, depending on the fan current consumption.

See Application Note AN771 “Suppressing Acoustic Noise in PWM Fan Speed Control Systems” for more information.

**FIGURE 4-1: REDUCING SWITCHING NOISE**

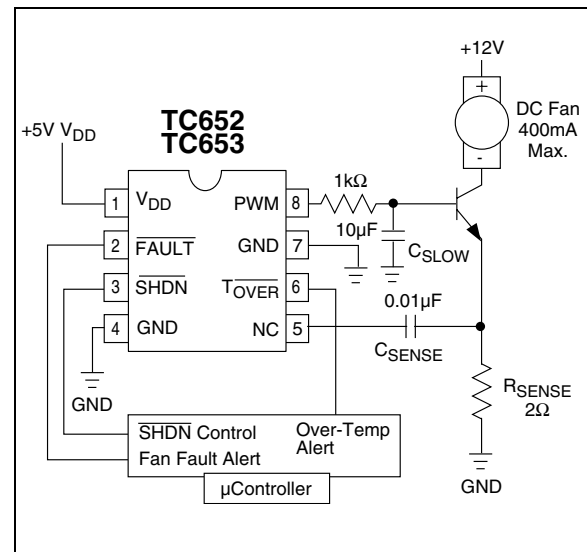

# TC652/TC653

## 5.0 TYPICAL CHARACTERISTICS

The graphs and tables provided following this note are a statistical summary based on a limited number of samples and are provided for informational purposes only. The performance characteristics listed herein are not tested or guaranteed. In some graphs or tables, the data presented may be outside the specified operating range (e.g., outside specified power supply range) and therefore outside the warranted range.

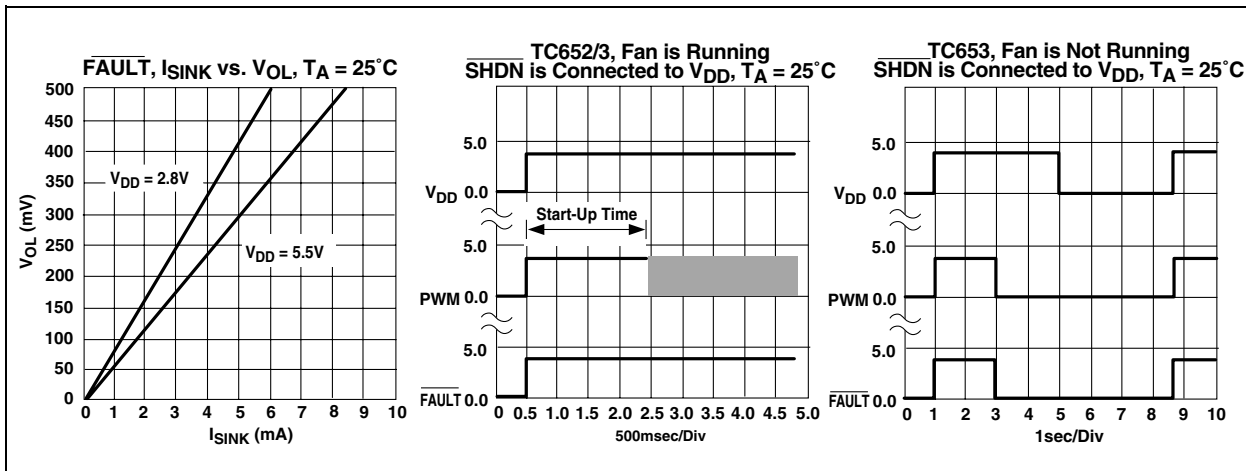
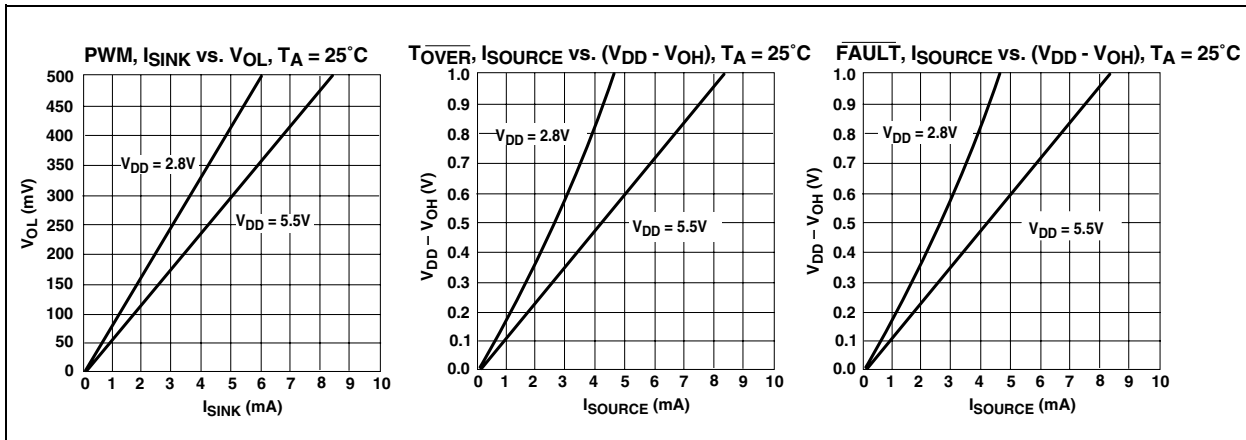
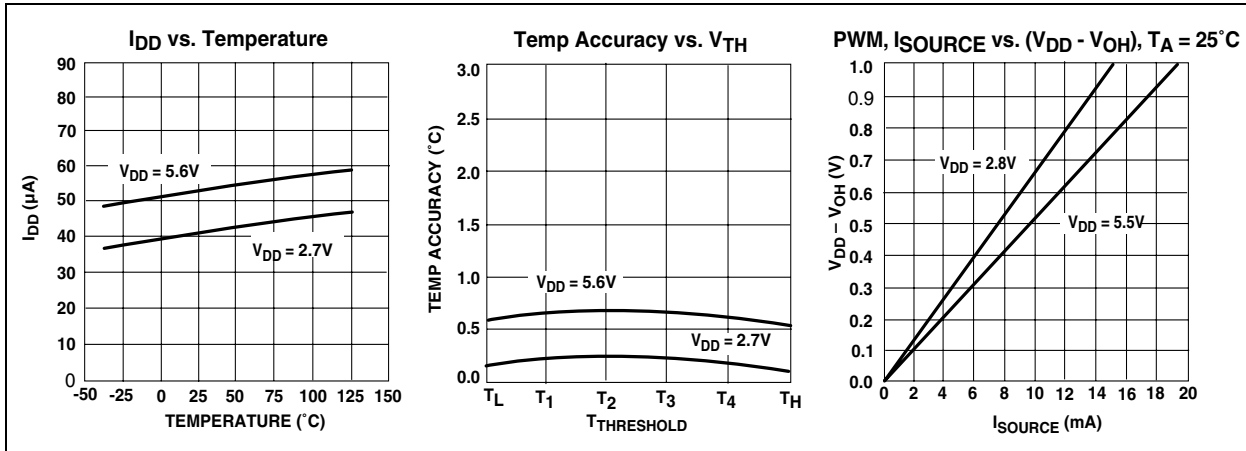



## 6.0 PACKAGING INFORMATION

### 6.1 Package Marking Information

Package marking data not available at this time.

### 6.2 Taping Form

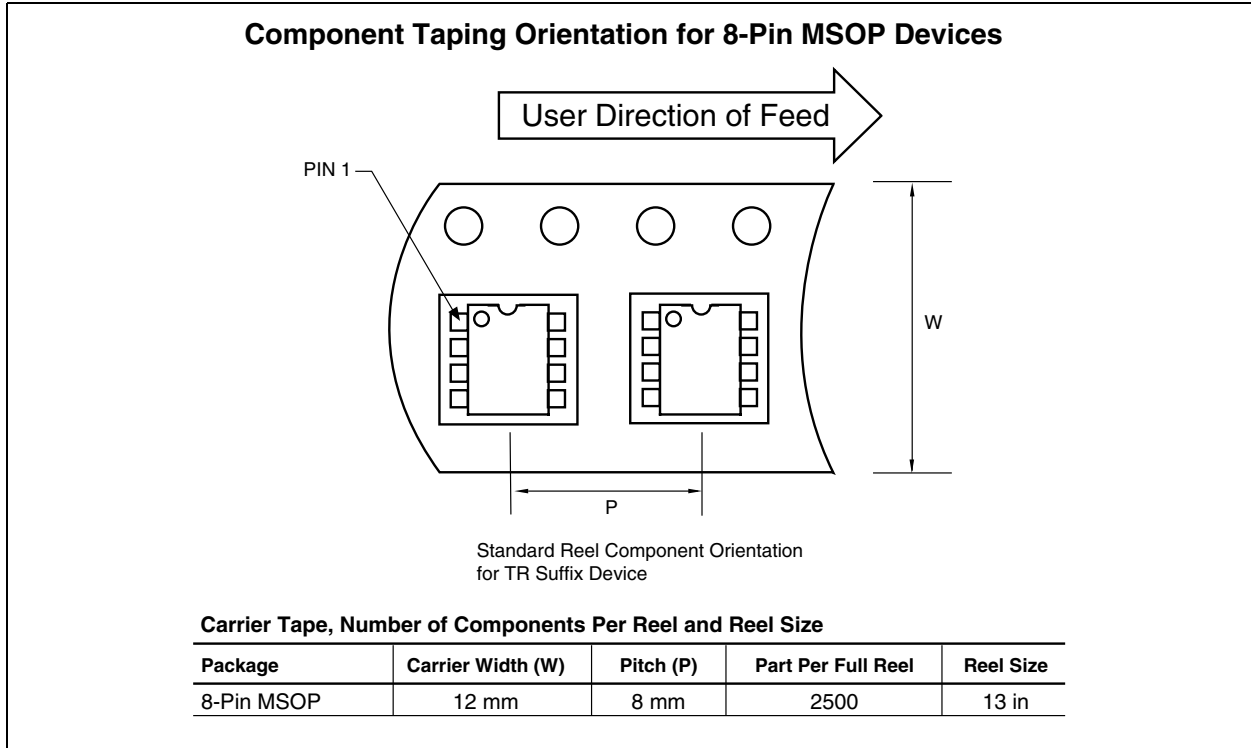

### 6.3 Package Dimensions

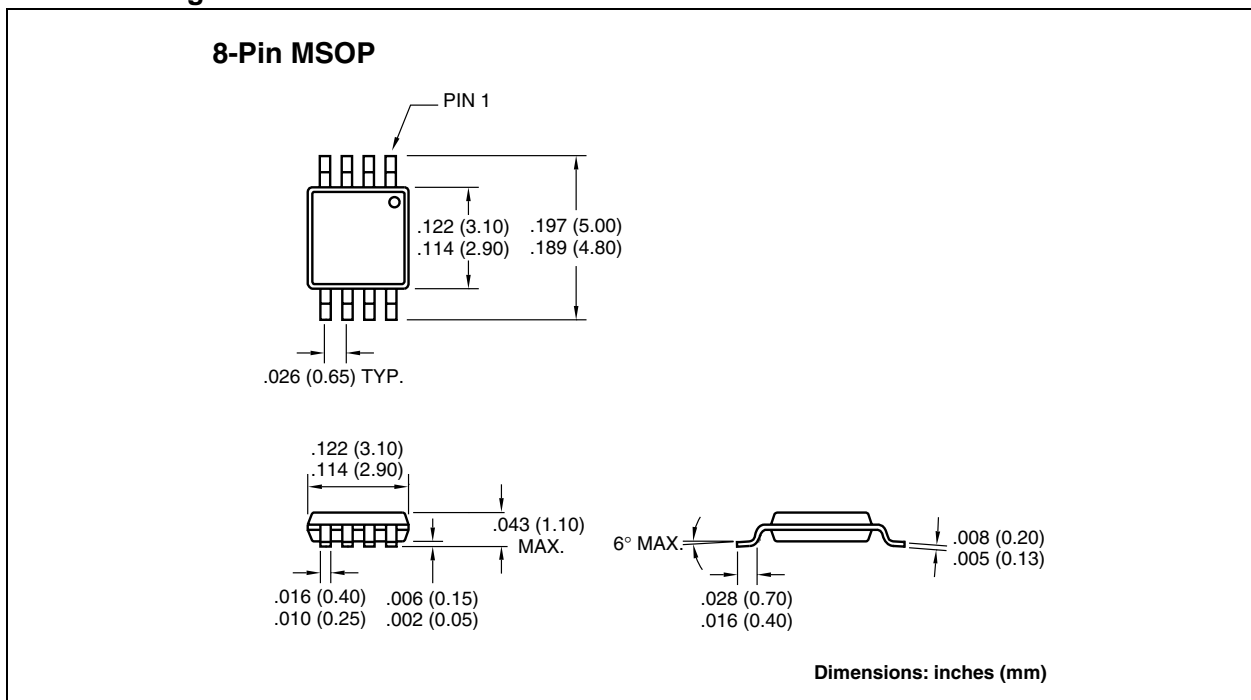

# TC652/TC653

---

---

NOTES:

## SALES AND SUPPORT

### **Data Sheets**

Products supported by a preliminary Data Sheet may have an errata sheet describing minor operational differences and recommended workarounds. To determine if an errata sheet exists for a particular device, please contact one of the following:

1. Your local Microchip sales office
2. The Microchip Corporate Literature Center U.S. FAX: (480) 792-7277
3. The Microchip Worldwide Site ([www.microchip.com](http://www.microchip.com))

Please specify which device, revision of silicon and Data Sheet (include Literature #) you are using.

### **New Customer Notification System**

Register on our web site ([www.microchip.com/cn](http://www.microchip.com/cn)) to receive the most current information on our products.

# TC652/TC653

---

---

NOTES:

Information contained in this publication regarding device applications and the like is intended through suggestion only and may be superseded by updates. It is your responsibility to ensure that your application meets with your specifications. No representation or warranty is given and no liability is assumed by Microchip Technology Incorporated with respect to the accuracy or use of such information, or infringement of patents or other intellectual property rights arising from such use or otherwise. Use of Microchip's products as critical components in life support systems is not authorized except with express written approval by Microchip. No licenses are conveyed, implicitly or otherwise, under any intellectual property rights.

## Trademarks

The Microchip name and logo, the Microchip logo, FilterLab, KEELOQ, microID, MPLAB, PIC, PICmicro, PICMASTER, PICSTART, PRO MATE, SEEVAL and The Embedded Control Solutions Company are registered trademarks of Microchip Technology Incorporated in the U.S.A. and other countries.

dsPIC, ECONOMONITOR, FanSense, FlexROM, fuzzyLAB, In-Circuit Serial Programming, ICSP, ICEPIC, microPort, Migratable Memory, MPASM, MPLIB, MPLINK, MPSIM, MXDEV, PICC, PICDEM, PICDEM.net, rfPIC, Select Mode and Total Endurance are trademarks of Microchip Technology Incorporated in the U.S.A.

Serialized Quick Turn Programming (SQTP) is a service mark of Microchip Technology Incorporated in the U.S.A.

All other trademarks mentioned herein are property of their respective companies.

© 2002, Microchip Technology Incorporated, Printed in the U.S.A., All Rights Reserved.

 Printed on recycled paper.

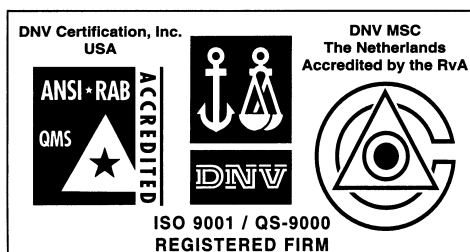

*Microchip received QS-9000 quality system certification for its worldwide headquarters, design and wafer fabrication facilities in Chandler and Tempe, Arizona in July 1999 and Mountain View, California in March 2002. The Company's quality system processes and procedures are QS-9000 compliant for its PICmicro® 8-bit MCUs, KEELOQ® code hopping devices, Serial EEPROMs, microperipherals, non-volatile memory and analog products. In addition, Microchip's quality system for the design and manufacture of development systems is ISO 9001 certified.*



# MICROCHIP

## WORLDWIDE SALES AND SERVICE

### AMERICAS

#### Corporate Office

2355 West Chandler Blvd.  
Chandler, AZ 85224-6199  
Tel: 480-792-7200 Fax: 480-792-7277  
Technical Support: 480-792-7627  
Web Address: <http://www.microchip.com>

#### Rocky Mountain

2355 West Chandler Blvd.  
Chandler, AZ 85224-6199  
Tel: 480-792-7966 Fax: 480-792-7456

#### Atlanta

500 Sugar Mill Road, Suite 200B  
Atlanta, GA 30350  
Tel: 770-640-0034 Fax: 770-640-0307

#### Boston

2 Lan Drive, Suite 120  
Westford, MA 01886  
Tel: 978-692-3848 Fax: 978-692-3821

#### Chicago

333 Pierce Road, Suite 180  
Itasca, IL 60143  
Tel: 630-285-0071 Fax: 630-285-0075

#### Dallas

4570 Westgrove Drive, Suite 160  
Addison, TX 75001  
Tel: 972-818-7423 Fax: 972-818-2924

#### Detroit

Tri-Atria Office Building  
32255 Northwestern Highway, Suite 190  
Farmington Hills, MI 48334  
Tel: 248-538-2250 Fax: 248-538-2260

#### Kokomo

2767 S. Albright Road  
Kokomo, Indiana 46902  
Tel: 765-864-8360 Fax: 765-864-8387

#### Los Angeles

18201 Von Karman, Suite 1090  
Irvine, CA 92612  
Tel: 949-263-1888 Fax: 949-263-1338

#### New York

150 Motor Parkway, Suite 202  
Hauppauge, NY 11788  
Tel: 631-273-5305 Fax: 631-273-5335

#### San Jose

Microchip Technology Inc.  
2107 North First Street, Suite 590  
San Jose, CA 95131  
Tel: 408-436-7950 Fax: 408-436-7955

#### Toronto

6285 Northam Drive, Suite 108  
Mississauga, Ontario L4V 1X5, Canada  
Tel: 905-673-0699 Fax: 905-673-6509

### ASIA/PACIFIC

#### Australia

Microchip Technology Australia Pty Ltd  
Suite 22, 41 Rawson Street  
Epping 2121, NSW  
Australia  
Tel: 61-2-9868-6733 Fax: 61-2-9868-6755

#### China - Beijing

Microchip Technology Consulting (Shanghai)  
Co., Ltd., Beijing Liaison Office  
Unit 915  
Bei Hai Wan Tai Bldg.  
No. 6 Chaoyangmen Beidajie  
Beijing, 100027, No. China  
Tel: 86-10-85282100 Fax: 86-10-85282104

#### China - Chengdu

Microchip Technology Consulting (Shanghai)  
Co., Ltd., Chengdu Liaison Office  
Rm. 2401, 24th Floor,  
Ming Xing Financial Tower  
No. 88 TIDU Street  
Chengdu 610016, China  
Tel: 86-28-86766200 Fax: 86-28-86766599

#### China - Fuzhou

Microchip Technology Consulting (Shanghai)  
Co., Ltd., Fuzhou Liaison Office  
Unit 28F, World Trade Plaza  
No. 71 Wusi Road  
Fuzhou 350001, China  
Tel: 86-591-7503506 Fax: 86-591-7503521

#### China - Shanghai

Microchip Technology Consulting (Shanghai)  
Co., Ltd.  
Room 701, Bldg. B  
Far East International Plaza  
No. 317 Xian Xia Road  
Shanghai, 200051  
Tel: 86-21-6275-5700 Fax: 86-21-6275-5060

#### China - Shenzhen

Microchip Technology Consulting (Shanghai)  
Co., Ltd., Shenzhen Liaison Office  
Rm. 1315, 13/F, Shenzhen Kerry Centre,  
Renminnan Lu  
Shenzhen 518001, China  
Tel: 86-755-2350361 Fax: 86-755-2366086

#### China - Hong Kong SAR

Microchip Technology Hongkong Ltd.  
Unit 901-6, Tower 2, Metroplaza  
223 Hing Fong Road  
Kwai Fong, N.T., Hong Kong  
Tel: 852-2401-1200 Fax: 852-2401-3431

#### India

Microchip Technology Inc.  
India Liaison Office  
Divyasree Chambers  
1 Floor, Wing A (A3/A4)  
No. 11, O'Shaugnessey Road  
Bangalore, 560 025, India  
Tel: 91-80-2290061 Fax: 91-80-2290062

### Japan

Microchip Technology Japan K.K.  
Benex S-1 6F  
3-18-20, Shinyokohama  
Kohoku-Ku, Yokohama-shi  
Kanagawa, 222-0033, Japan  
Tel: 81-45-471-6166 Fax: 81-45-471-6122

### Korea

Microchip Technology Korea  
168-1, Youngbo Bldg. 3 Floor  
Samsung-Dong, Kangnam-Ku  
Seoul, Korea 135-882  
Tel: 82-2-554-7200 Fax: 82-2-558-5934

### Singapore

Microchip Technology Singapore Pte Ltd.  
200 Middle Road  
#07-02 Prime Centre  
Singapore, 188980  
Tel: 65-6334-8870 Fax: 65-6334-8850

### Taiwan

Microchip Technology Taiwan  
11F-3, No. 207  
Tung Hua North Road  
Taipei, 105, Taiwan  
Tel: 886-2-2717-7175 Fax: 886-2-2545-0139

### EUROPE

#### Denmark

Microchip Technology Nordic ApS  
Regus Business Centre  
Lautrup høj 1-3  
Ballerup DK-2750 Denmark  
Tel: 45 4420 9895 Fax: 45 4420 9910

#### France

Microchip Technology SARL  
Parc d'Activite du Moulin de Massy  
43 Rue du Saule Trapu  
Batiment A - 1er Etage  
91300 Massy, France  
Tel: 33-1-69-53-63-20 Fax: 33-1-69-30-90-79

#### Germany

Microchip Technology GmbH  
Gustav-Heinemann Ring 125  
D-81739 Munich, Germany  
Tel: 49-89-627-144 0 Fax: 49-89-627-144-44

#### Italy

Microchip Technology SRL  
Centro Direzionale Colleoni  
Palazzo Taurus 1 V. Le Colleoni 1  
20041 Agrate Brianza  
Milan, Italy  
Tel: 39-039-65791-1 Fax: 39-039-6899883

#### United Kingdom

Microchip Ltd.  
505 Eskdale Road  
Winnersh Triangle  
Wokingham  
Berkshire, England RG41 5TU  
Tel: 44 118 921 5869 Fax: 44-118 921-5820

04/20/02

