

## N- and P-Channel Enhancement-Mode Dual MOSFET

### Features

- ▶ Back to back gate-source Zener diodes
- ▶ Guaranteed  $R_{DS(ON)}$  at 4.0V gate drive
- ▶ Low threshold
- ▶ Low on-resistance
- ▶ Independent N- and P-channels
- ▶ Electrically isolated N- and P-channels
- ▶ Low input capacitance
- ▶ Fast switching speeds
- ▶ Free from secondary breakdowns
- ▶ Low input and output leakage

### Applications

- ▶ High voltage pulsers
- ▶ Amplifiers
- ▶ Buffers
- ▶ Piezoelectric transducer drivers
- ▶ General purpose line drivers
- ▶ Logic level interfaces

### General Description

The Supertex TC6215 consists of high voltage, low threshold N-channel and P-channel MOSFETs in an 8-Lead SOIC (TG) package. Both MOSFETs have integrated back to back gate-source Zener diode clamps and guaranteed  $R_{DS(ON)}$  ratings down to 4.0V gate drive allowing them to be driven directly with standard 5.0V CMOS logic.

These low threshold enhancement-mode (normally-off) transistors utilize an advanced vertical DMOS structure and Supertex's well-proven silicon-gate manufacturing process. This combination produces devices with the power handling capabilities of bipolar transistors and with the high input impedance and positive temperature coefficient inherent in MOS devices. Characteristic of all MOS structures, these devices are free from thermal runaway and thermally-induced secondary breakdown.

Supertex's vertical DMOS FETs are ideally suited to a wide range of switching and amplifying applications where very low threshold voltage, high breakdown voltage, high input impedance, low input capacitance, and fast switching speeds are desired.

### Ordering Information

| Device | Package Option<br>8-Lead SOIC<br>4.90x3.90mm body<br>1.75mm height (max)<br>1.27mm pitch | $BV_{DSS}/BV_{DGS}$ |                  | $R_{DS(ON)}$ (Max)        |                           |
|--------|--|---------------------|------------------|---------------------------|---------------------------|
|        |  | N-Channel<br>(V)    | P-Channel<br>(V) | N-Channel<br>( $\Omega$ ) | P-Channel<br>( $\Omega$ ) |
| TC6215 | TC6215TG-G   | 150                 | -150             | 4.0                       | 7.0                       |



-G indicates package is RoHS compliant ('Green')

### Absolute Maximum Ratings

| Parameter                         | Value            |
|-----------------------------------|------------------|
| Drain-to-source voltage           | $BV_{DSS}$       |
| Drain-to-gate voltage             | $BV_{DGS}$       |
| Gate-to-source voltage            | $\pm 20V$        |
| Operating and storage temperature | -55°C to + 150°C |
| Soldering temperature*            | 300°C            |

Absolute Maximum Ratings are those values beyond which damage to the device may occur. Functional operation under these conditions is not implied. Continuous operation of the device at the absolute rating level may affect device reliability. All voltages are referenced to device ground.

\* Distance of 1.6mm from case for 10 seconds.

### Pin Configuration



### Product Marking

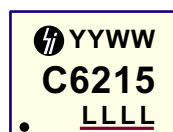

YY = Year Sealed  
 WW = Week Sealed  
 L = Lot Number  
 \_\_\_\_\_ = "Green" Packaging

Package may or may not include the following marks: Si or

**8-Lead SOIC (TG)**

**N-Channel Electrical Characteristics** ( $T_A = 25^\circ\text{C}$  unless otherwise specified)

| Sym                 | Parameter                                  | Min      | Typ  | Max      | Units    | Conditions  |
|---------------------|--|----------|------|----------|----------|---|
| $BV_{DSS}$          | Drain-to-source breakdown voltage          | 150      | -    | -        | V        | $V_{GS} = 0V, I_D = 1.0mA$  |
| $V_{GS(th)}$        | Gate threshold voltage                     | 1.0      | -    | 2.0      | V        | $V_{GS} = V_{DS}, I_D = 1.0mA$  |
| $\Delta V_{GS(th)}$ | Change in $V_{GS(th)}$ with temperature    | -        | -    | -4.5     | mV/°C    | $V_{GS} = V_{DS}, I_D = 1.0mA$  |
| $VZ_{GS}$           | Gate-source back to back Zener voltage     | $\pm 14$ | -    | $\pm 25$ | V        | $I_{GS} = \pm 1.0mA$  |
| $I_{DSS}$           | Zero gate voltage drain current            | -        | -    | 5.0      | $\mu A$  | $V_{GS} = 0V, V_{DS} = \text{Max Rating}$                               |
|                     |  | -        | -    | 1.0      | mA       | $V_{DS} = 0.8 \text{ Max Rating}, V_{GS} = 0V, T_A = 125^\circ\text{C}$ |
| $I_{D(ON)}$         | On-state drain current                     | -        | 2.0  | -        | A        | $V_{GS} = 4.5V, V_{DS} = 25V$   |
|                     |  | -        | 3.8  | -        |          | $V_{GS} = 10V, V_{DS} = 25V$  |
| $R_{DS(ON)}$        | Static drain-to-source on-state resistance | -        | -    | 4.0      | $\Omega$ | $V_{GS} = 4.0V, I_D = 0.5A$   |
|                     |  | -        | -    | 5.0      |          | $V_{GS} = 5.0V, I_D = 2.0A$   |
|                     |  | -        | -    | 4.0      |          | $V_{GS} = 10V, I_D = 2.0A$  |
| $\Delta R_{DS(ON)}$ | Change in $R_{DS(ON)}$ with temperature    | -        | -    | 1.0      | %/°C     | $V_{GS} = 5.0V, I_D = 2.0A$   |
| $G_{FS}$            | Forward transconductance                   | 560      | -    | -        | mmho     | $V_{DS} = 10V, I_D = 0.5A$  |
| $C_{ISS}$           | Input capacitance                          | -        | 120  | -        | pF       | $V_{GS} = 0V, V_{DS} = 25V, f = 1.0MHz$                                 |
| $C_{OSS}$           | Common source output capacitance           | -        | 33   | -        |          |   |
| $C_{RSS}$           | Reverse transfer capacitance               | -        | 11   | -        |          |   |
| $t_{d(ON)}$         | Turn-on delay time                         | -        | 2.5  | -        | ns       | $V_{DD} = 25V, I_D = 1.0A, R_{GEN} = 25\Omega$                          |
| $t_r$               | Rise time                                  | -        | 2.3  | -        |          |   |
| $t_{d(OFF)}$        | Turn-off delay time                        | -        | 17.2 | -        |          |   |
| $t_f$               | Fall time                                  | -        | 11.3 | -        |          |   |
| $V_{SD}$            | Diode forward voltage drop                 | -        | -    | 1.4      | V        | $V_{GS} = 0V, I_{SD} = 0.5A$  |
| $t_{rr}$            | Reverse recovery time                      | -        | 90   | -        | ns       | $V_{GS} = 0V, I_{SD} = 0.5A$  |

**Notes:**

1. All DC parameters 100% tested at  $25^\circ\text{C}$  unless otherwise stated. (Pulsed test:  $300\mu s$  pulse at 2% duty cycle.)
2. All AC parameters sample tested.

**N-Channel Switching Waveforms and Test Circuit**

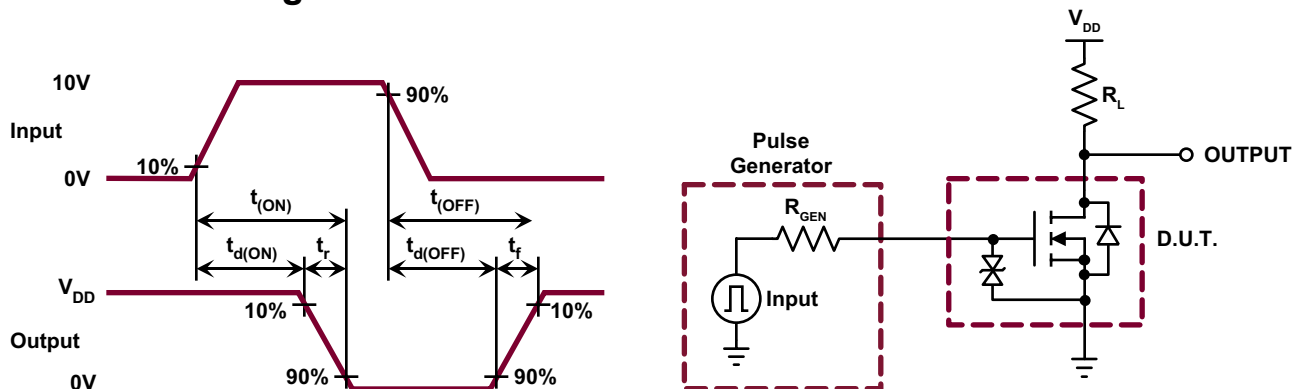

**P-Channel Electrical Characteristics** ( $T_A = 25^\circ\text{C}$  unless otherwise specified)

| Sym                 | Parameter                                  | Min      | Typ  | Max      | Units    | Conditions  |
|---------------------|--|----------|------|----------|----------|---|
| $BV_{DSS}$          | Drain-to-source breakdown voltage          | -150     | -    | -        | V        | $V_{GS} = 0V, I_D = -1.0mA$   |
| $V_{GS(th)}$        | Gate threshold voltage                     | -1.0     | -    | -2.0     | V        | $V_{GS} = V_{DS}, I_D = -1.0mA$   |
| $\Delta V_{GS(th)}$ | Change in $V_{GS(th)}$ with temperature    | -        | -    | 4.5      | mV/°C    | $V_{GS} = V_{DS}, I_D = -1.0mA$   |
| $VZ_{GS}$           | Gate-source back to back Zener voltage     | $\pm 14$ | -    | $\pm 25$ | V        | $I_{GS} = \pm 1.0mA$  |
| $I_{DSS}$           | Zero gate voltage drain current            | -        | -    | -5.0     | $\mu A$  | $V_{GS} = 0V, V_{DS} = \text{Max Rating}$                               |
|                     |  | -        | -    | -1.0     | mA       | $V_{DS} = 0.8 \text{ Max Rating}, V_{GS} = 0V, T_A = 125^\circ\text{C}$ |
| $I_{D(ON)}$         | On-state drain current                     | -        | -1.5 | -        | A        | $V_{GS} = -4.5V, V_{DS} = -25V$   |
|                     |  | -        | -3.0 | -        |          | $V_{GS} = -10V, V_{DS} = -25V$  |
| $R_{DS(ON)}$        | Static drain-to-source on-state resistance | -        | -    | 7.5      | $\Omega$ | $V_{GS} = -4.0V, I_D = -0.25A$  |
|                     |  | -        | -    | 9.0      |          | $V_{GS} = -5.0V, I_D = -1.0A$   |
|                     |  | -        | -    | 7.0      |          | $V_{GS} = -10V, I_D = -2.0A$  |
| $\Delta R_{DS(ON)}$ | Change in $R_{DS(ON)}$ with temperature    | -        | -    | 1.0      | %/°C     | $V_{GS} = -5.0V, I_D = -0.25A$  |
| $G_{FS}$            | Forward transconductance                   | 290      | -    | -        | mmho     | $V_{DS} = -10V, I_D = -0.25A$   |
| $C_{ISS}$           | Input capacitance                          | -        | 127  | -        | pF       | $V_{GS} = 0V, V_{DS} = -25V, f = 1.0MHz$                                |
| $C_{OSS}$           | Common source output capacitance           | -        | 29   | -        |          |   |
| $C_{RSS}$           | Reverse transfer capacitance               | -        | 9.0  | -        |          |   |
| $t_{d(ON)}$         | Turn-on delay time                         | -        | 2.4  | -        | ns       | $V_{DD} = -25V, I_D = -1.0A, R_{GEN} = 25\Omega$                        |
| $t_r$               | Rise time                                  | -        | 2.3  | -        |          |   |
| $t_{d(OFF)}$        | Turn-off delay time                        | -        | 16.2 | -        |          |   |
| $t_f$               | Fall time                                  | -        | 11.1 | -        |          |   |
| $V_{SD}$            | Diode forward voltage drop                 | -        | -    | -1.4     | V        | $V_{GS} = 0V, I_{SD} = -0.25A$  |
| $t_{rr}$            | Reverse recovery time                      | -        | 80   | -        | ns       | $V_{GS} = 0V, I_{SD} = -0.25A$  |

**Notes:**

1. All DC parameters 100% tested at 25°C unless otherwise stated. (Pulsed test: 300µs pulse at 2% duty cycle.)
2. All AC parameters sample tested.

**P-Channel Switching Waveforms and Test Circuit**

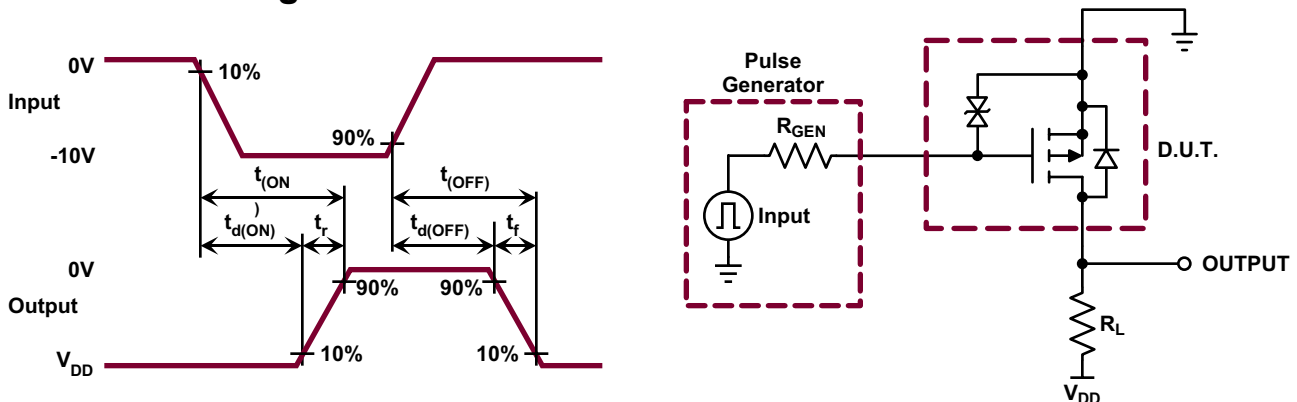

Block Diagram

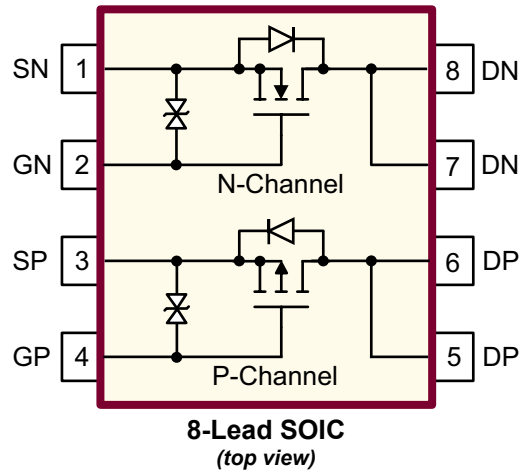

Typical Performance Curves

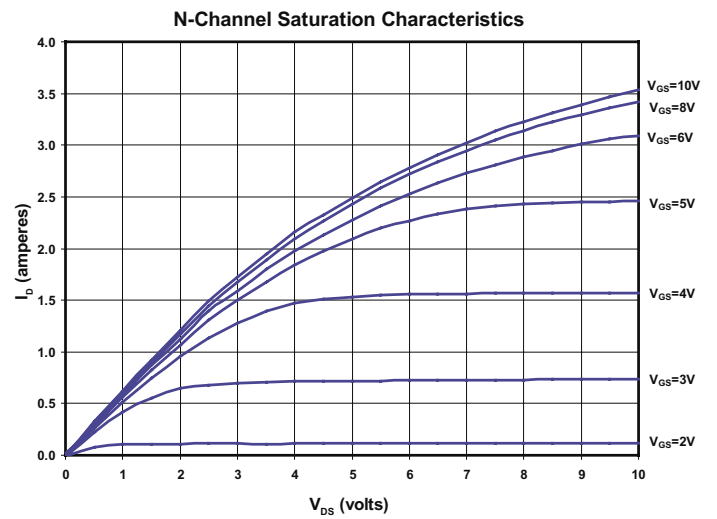
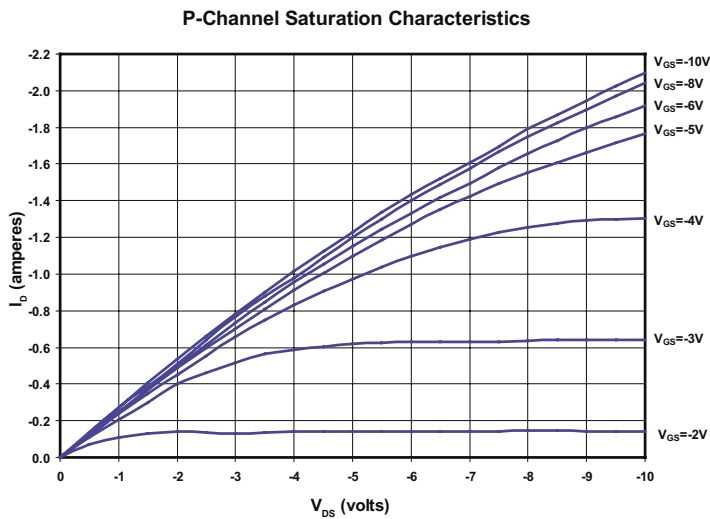
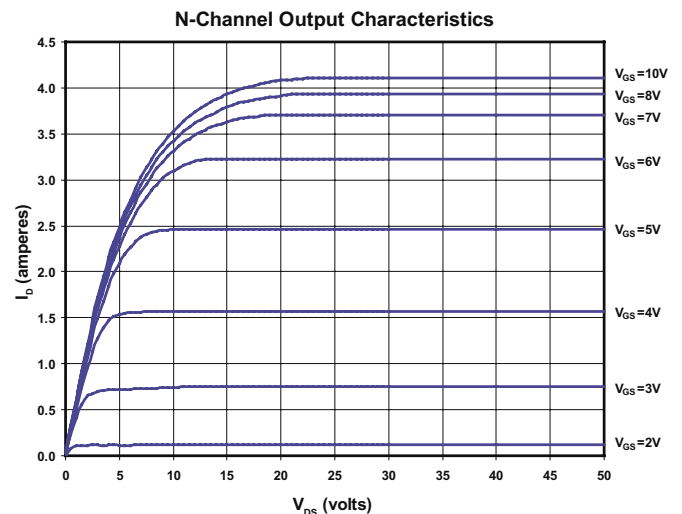
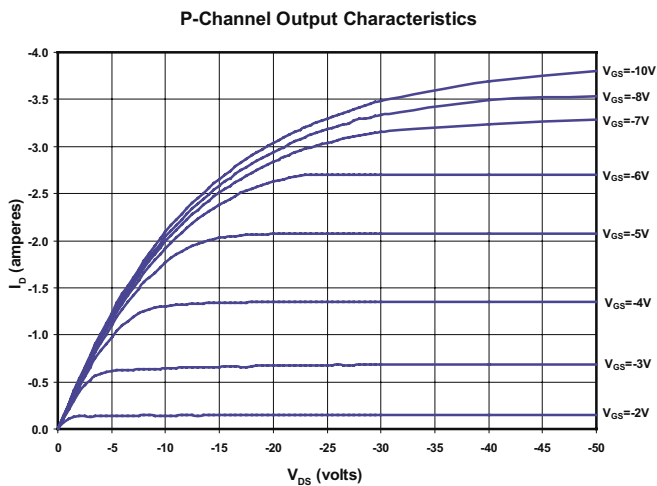

# 8-Lead SOIC (Narrow Body) Package Outline (TG)

4.90x3.90mm body, 1.75mm height (max), 1.27mm pitch

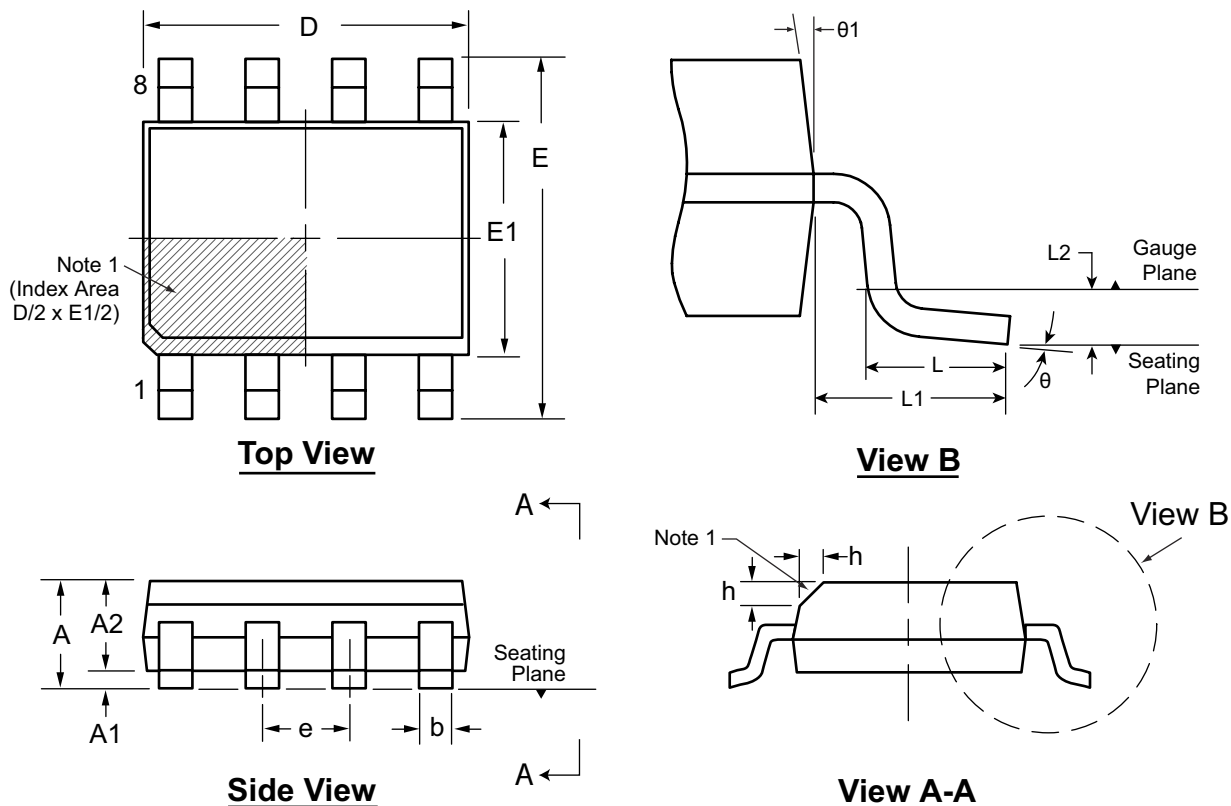

**Note:**  
 1. This chamfer feature is optional. A Pin 1 identifier must be located in the index area indicated. The Pin 1 identifier can be: a molded mark/identifier; an embedded metal marker; or a printed indicator.

| Symbol         | A   | A1    | A2   | b     | D    | E     | E1    | e     | h        | L    | L1   | L2       | θ        | θ1 |     |
|----------------|-----|-------|------|-------|------|-------|-------|-------|----------|------|------|----------|----------|----|-----|
| Dimension (mm) | MIN | 1.35* | 0.10 | 1.25  | 0.31 | 4.80* | 5.80* | 3.80* | 1.27 BSC | 0.25 | 0.40 | 1.04 REF | 0.25 BSC | 0° | 5°  |
|                | NOM | -     | -    | -     | -    | 4.90  | 6.00  | 3.90  |          | -    | -    |          |          | -  | -   |
|                | MAX | 1.75  | 0.25 | 1.65* | 0.51 | 5.00* | 6.20* | 4.00* |          | 0.50 | 1.27 |          |          | 8° | 15° |

JEDEC Registration MS-012, Variation AA, Issue E, Sept. 2005.  
 \* This dimension is not specified in the original JEDEC drawing. The value listed is for reference only.  
**Drawings are not to scale.**  
 Supertex Doc. #: DSPD-8SOLGTG, Version H101708.

(The package drawing(s) in this data sheet may not reflect the most current specifications. For the latest package outline information go to <http://www.supertex.com/packaging.html>.)

Supertex inc. does not recommend the use of its products in life support applications, and will not knowingly sell them for use in such applications unless it receives an adequate "product liability indemnification insurance agreement." Supertex inc. does not assume responsibility for use of devices described, and limits its liability to the replacement of the devices determined defective due to workmanship. No responsibility is assumed for possible omissions and inaccuracies. Circuitry and specifications are subject to change without notice. For the latest product specifications refer to the Supertex inc. website: <http://www.supertex.com>.