

Positive Doubling Charge Pumps with Shutdown in a SOT-23 Package

Features

- Charge Pumps in 6-Pin SOT-23A Package
- >99% Typical Voltage Conversion Efficiency
- Voltage Doubling
- Input Voltage Range, TC1240: +2.5V to +4.0V,
TC1240A: +2.5V to +5.5V
- Low Output Resistance, TC1240: 17 Ω (Typical)
TC1240A: 12 Ω (Typical)
- Only Two External Capacitors Required
- Low Supply Current, TC1240: 180 μ A (Typical)
TC1240A: 550 μ A (Typical)
- Power-Saving Shutdown Mode (1 μ A Maximum)
- Shutdown Input Fully Compatible with 1.8V Logic Systems

Applications

- Cellular Phones
- Pagers
- PDAs, Portable Data Loggers
- Battery Powered Devices
- Handheld Instruments

Package Type

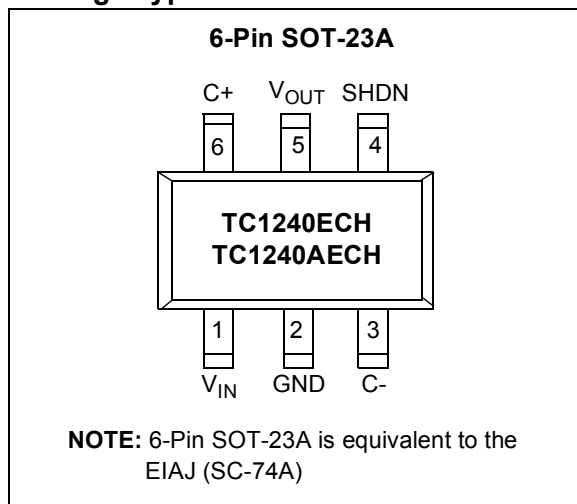

General Description

The TC1240/TC1240A is a doubling CMOS charge pump voltage converter in a small 6-Pin SOT-23A package. The TC1240 doubles an input voltage that can range from +2.5V to +4.0V, while the TC1240A doubles an input voltage that can range from +2.5V to +5.5V. Conversion efficiency is typically >99%. Internal oscillator frequency is 160 kHz for both devices. The TC1240 and TC1240A have an active-high shutdown that limits the current consumption of the devices to less than 1 μ A.

External component requirement is only two capacitors for standard voltage doubler applications. All other circuitry (including control, oscillator and power MOSFETs) are integrated on-chip. Typical supply current is 180 μ A for the TC1240 and 550 μ A for the TC1240A. Both devices are available in a 6-Pin SOT-23A surface mount package.

Typical Application Circuit

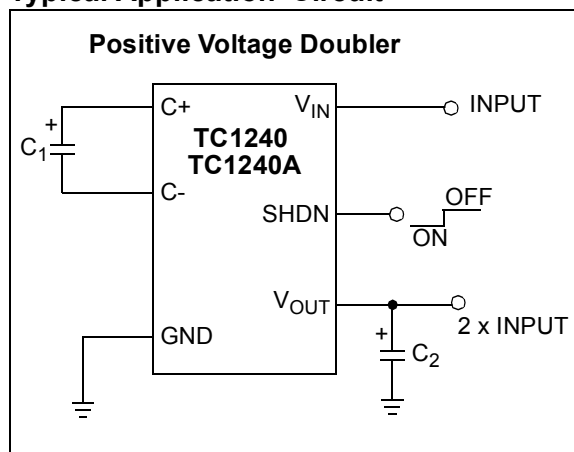

TC1240/TC1240A

1.0 ELECTRICAL CHARACTERISTICS

Absolute Maximum Ratings †

Input Voltage (V_{IN} to GND)	
TC1240	+4.5V, -0.3V
TC1240A	+5.8V, -0.3V
Output Voltage (V_{OUT} to GND)	
TC1240	+9.0V, V_{IN} -0.3V
TC1240A	+11.6V, V_{IN} -0.3V
Current at V_{OUT} Pin.....	50 mA
Short-Circuit Duration: V_{OUT} to GND	Indefinite
Thermal Resistance	210°C/W
Power Dissipation ($T_A = +25^\circ\text{C}$).....	600 mW
Operating Temperature Range.....	-40°C to +85°C
Storage Temperature (Unbiased).....	-65°C to +150°C

† Stresses above those listed under “Absolute Maximum Ratings” may cause permanent damage to the device. These are stress ratings only and functional operation of the device at these or any other conditions above those indicated in the operation sections of the specifications is not implied. Exposure to Absolute Maximum Rating conditions for extended periods may affect device reliability.

TC1240 ELECTRICAL SPECIFICATIONS

Electrical Specifications: Unless otherwise noted, typical values apply at $T_A = +25^\circ\text{C}$. Minimum and maximum values apply for $T_A = -40^\circ\text{C}$ to $+85^\circ\text{C}$, and $V_{IN} = +2.8\text{V}$, $C_1 = C_2 = 3.3 \mu\text{F}$, SHDN = GND.

Parameters	Sym	Min	Typ	Max	Units	Conditions
Supply Current	I_{DD}	—	180	300	μA	$R_{LOAD} = \infty$
Shutdown Supply Current	I_{SHDN}	—	0.1	1.0	μA	SHDN = V_{IN}
Minimum Supply Voltage	V_{MIN}	2.5	—	—	V	$R_{LOAD} = 1.0 \text{ k}\Omega$
Maximum Supply Voltage	V_{MAX}	—	—	4.0	V	$R_{LOAD} = 1.0 \text{ k}\Omega$
Oscillator Frequency	F_{OSC}	—	160	—	kHz	$T_A = -40^\circ\text{C}$ to $+85^\circ\text{C}$
Switching Frequency (Note 1)	F_{SW}	40	80	125	kHz	$T_A = -40^\circ\text{C}$ to $+85^\circ\text{C}$
Shutdown Input Logic High	V_{IH}	1.4	—	—	V	$V_{IN} = V_{MIN}$ to V_{MAX}
Shutdown Input Logic Low	V_{IL}	—	—	0.4	V	$V_{IN} = V_{MIN}$ to V_{MAX}
Power Efficiency	P_{EFF}	86	93	—	%	$R_{LOAD} = 1.0 \text{ k}\Omega$
Voltage Conversion Efficiency	V_{EFF}	97.5	99.96	—	%	$R_{LOAD} = \infty$
Output Resistance (Note 2)	R_{OUT}	—	17	—	Ω	$R_{LOAD} = 1.0 \text{ k}\Omega$ $T_A = -40^\circ\text{C}$ to $+85^\circ\text{C}$
		—	—	30		

Note 1: Switching frequency is one-half internal oscillator frequency.

Note 2: Capacitor contribution is approximately 26% of the output impedance [$\text{ESR} = 1 / \text{switching frequency} \times \text{capacitance}$].

TC1240A ELECTRICAL SPECIFICATIONS

Electrical Specifications: Unless otherwise noted, typical values apply at $T_A = +25^\circ\text{C}$. Minimum and maximum values apply for $T_A = -40^\circ$ to $+85^\circ\text{C}$, and $V_{IN} = +5.0\text{V}$, $C_1 = C_2 = 3.3 \mu\text{F}$, $\text{SHDN} = \text{GND}$.

Parameters	Sym	Min	Typ	Max	Units	Conditions
Supply Current	I_{DD}	—	550	900	μA	$R_{LOAD} = \infty$
Shutdown Supply Current	I_{SHDN}	—	0.01	1.0	μA	$\text{SHDN} = V_{IN}$
Minimum Supply Voltage	V_{MIN}	2.5	—	—	V	
Maximum Supply Voltage	V_{MAX}	—	—	5.5	V	
Output Current	I_{LOAD}	20	—	—	mA	
Sum of the $R_{DS(ON)}$ of the internal MOSFET Switches	R_{SW}	—	4	8	Ω	$I_{LOAD} = 20 \text{ mA}$
Oscillator Frequency	F_{OSC}	—	160	—	kHz	$T_A = -40^\circ\text{C}$ to $+85^\circ\text{C}$
Switching Frequency (Note 1)	F_{SW}	40	80	125	kHz	$T_A = -40^\circ\text{C}$ to $+85^\circ\text{C}$
Shutdown Input Logic High	V_{IH}	1.4	—	—	V	$V_{IN} = V_{MIN}$ to V_{MAX}
Shutdown Input Logic Low	V_{IL}	—	—	0.4	V	$V_{IN} = V_{MIN}$ to V_{MAX}
Power Efficiency	P_{EFF}	86	94	—	%	$I_{LOAD} = 5 \text{ mA}$
Voltage Conversion Efficiency	V_{EFF}	99	99.96	—	%	$R_{LOAD} = \infty$
Output Resistance (Note 2)	R_{OUT}	—	12	—	Ω	$I_{LOAD} = 20 \mu\text{A}$ $T_A = -40^\circ\text{C}$ to $+85^\circ\text{C}$

Note 1: Switching frequency is one-half internal oscillator frequency.

2: Capacitor contribution is approximately 26% of the output impedance [$\text{ESR} = 1 / \text{switching frequency} \times \text{capacitance}$].

TC1240/TC1240A

2.0 TYPICAL PERFORMANCE CURVES

Note: The graphs and tables provided following this note are a statistical summary based on a limited number of samples and are provided for informational purposes only. The performance characteristics listed herein are not tested or guaranteed. In some graphs or tables, the data presented may be outside the specified operating range (e.g., outside specified power supply range) and therefore outside the warranted range.

Note: Unless otherwise indicated, typical values apply at $T_A = +25^\circ\text{C}$.

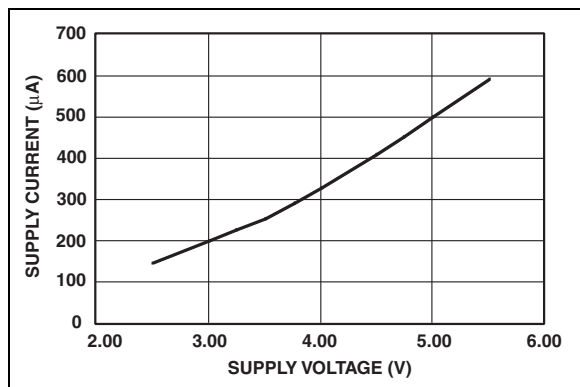

FIGURE 2-1: Supply Current vs. Supply Voltage (No Load).

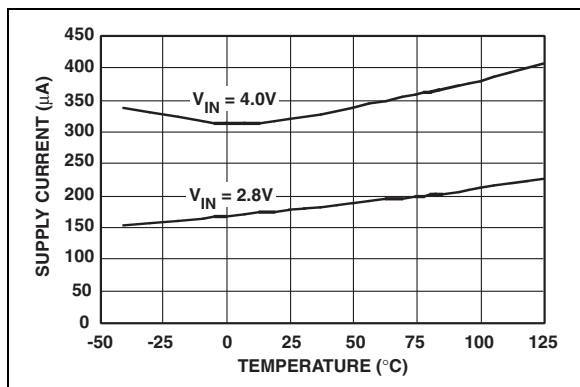

FIGURE 2-4: Supply Current vs. Temperature (No Load).

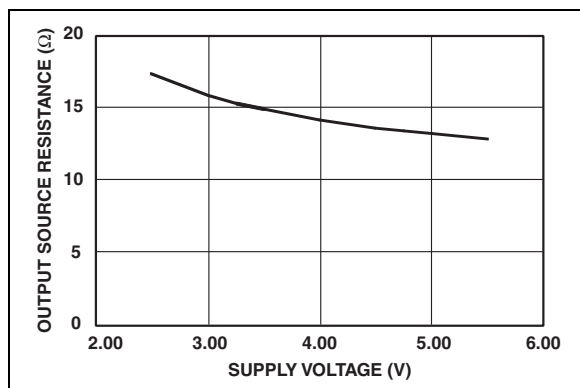

FIGURE 2-2: Output Source Resistance vs. Supply Voltage (with $R_{LOAD} = 1\text{ k}\Omega$)

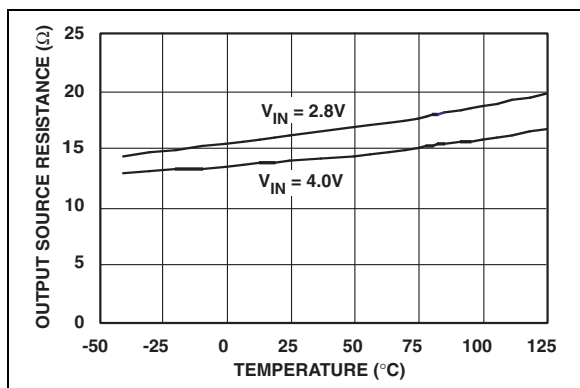

FIGURE 2-5: Output Source Resistance vs. Temperature (with $R_{LOAD} = 1\text{ k}\Omega$).

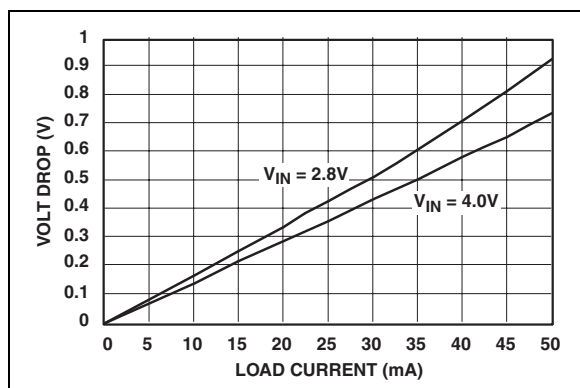

FIGURE 2-3: Output Voltage Drop vs. Load Current.

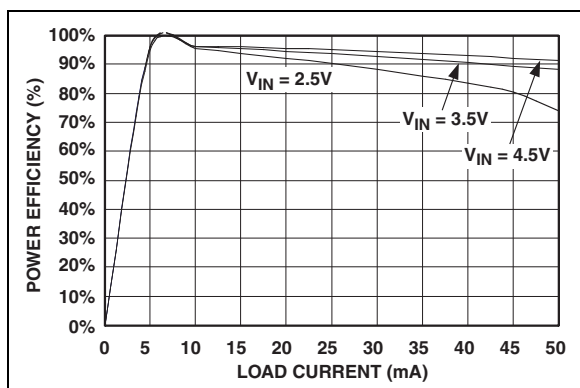

FIGURE 2-6: Power Efficiency vs. Load Current.

Note: Unless otherwise indicated, typical values apply at $T_A = +25^\circ\text{C}$.

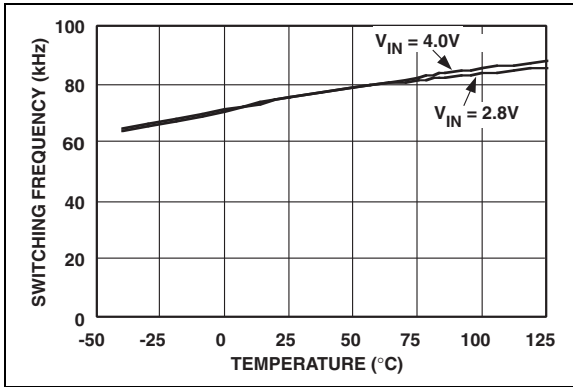

FIGURE 2-7: Switching Frequency vs. Temperature.

TC1240/TC1240A

3.0 PIN DESCRIPTION

The description of the pins are listed in Table 3-1.

TABLE 3-1: PIN FUNCTION TABLE

Pin No.	Symbol	Description
1	V_{IN}	Power supply input
2	GND	Ground
3	C-	Commutation capacitor negative terminal
4	SHDN	Shutdown input (active high)
5	V_{OUT}	Doubled output voltage
6	C+	Commutation capacitor positive terminal

4.0 DETAILED DESCRIPTION

The TC1240/TC1240A charge pump converter doubles the voltage applied to the V_{IN} pin. Conversion consists of a two-phase operation (Figure 4-1). During the first phase, switches S_2 and S_4 are open and S_1 and S_3 are closed. During this time, C_1 charges to the voltage on V_{IN} and load current is supplied from C_2 . During the second phase, S_2 and S_4 are closed, while S_1 and S_3 are open.

During this second phase, C_1 is level-shifted upward by V_{IN} volts. This connects C_1 to the reservoir capacitor C_2 , allowing energy to be delivered to the output as needed. The actual voltage is slightly lower than $2 \times V_{IN}$ since the four switches (S_1 - S_4) have an on-resistance and the load drains charge from reservoir capacitor C_2 .

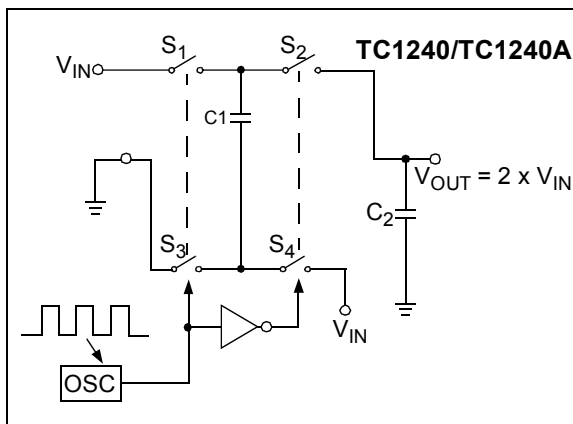

FIGURE 4-1: Ideal Switched Capacitor Charge Pump Doubler.

5.0 TYPICAL APPLICATIONS

5.1 Output Voltage Considerations

The TC1240/TC1240A performs voltage doubling but does not provide regulation. The output voltage will droop in a linear manner with respect to load current. The value of this equivalent output resistance is approximately 12Ω nominal at $+25^\circ\text{C}$ and $V_{IN} = +5.0\text{V}$ for the TC1240A and 17Ω nominal at $+25^\circ\text{C}$ and $V_{IN} = +2.8\text{V}$ for the TC1240. V_{OUT} is approximately $+10.0\text{V}$ at light loads for the TC1240A and $+5.6\text{V}$ for the TC1240, and droops according to the equation below:

EQUATION

$$V_{DROOP} = I_{OUT} \times R_{OUT}$$

$$V_{OUT} = 2 \times V_{IN} - V_{DROOP}$$

5.2 Charge Pump Efficiency

The overall power efficiency of the charge pump is affected by four factors:

1. Losses from power consumed by the internal oscillator, switch drive, etc. (which vary with input voltage, temperature and oscillator frequency).
2. I^2R losses due to the on-resistance of the MOSFET switches on-board the charge pump.
3. Charge pump capacitor losses due to effective series resistance (ESR).
4. Losses that occur during charge transfer (from commutation capacitor to the output capacitor) when a voltage difference between the two capacitors exist.

Most of the conversion losses are due to factors (2) and (3) above. These losses are given by Equation 5-1.

EQUATION 5-1:

$$\text{a) } P_{LOSS(2,3)} = I_{OUT}^2 \times R_{OUT}$$

$$\text{b) } R_{OUT} = \left[\frac{I}{F_{SW}(C_1)} \right] + 8R_{SWITCH} + 4ESR_{C1} + ESR_{C2}$$

TC1240/TC1240A

The switching frequency in Equation 5-1b is defined as one-half the oscillator frequency (i.e., $F_{SW} = F_{OSC}/2$). The $1/(F_{SW})(C_1)$ term in Equation 5-1b is the effective output resistance of an ideal switched capacitor circuit (Figure 5-1 and Figure 5-2).

The output voltage ripple is given by Equation 5-2.

EQUATION 5-2:

$$V_{RIPPLE} = \frac{I_{OUT}}{2(F_{SW})(C_2)} + 2(I_{OUT})(ESR_{C_2})$$

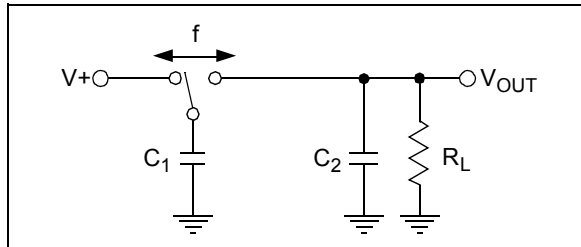

FIGURE 5-1: Ideal Switched Capacitor Model.

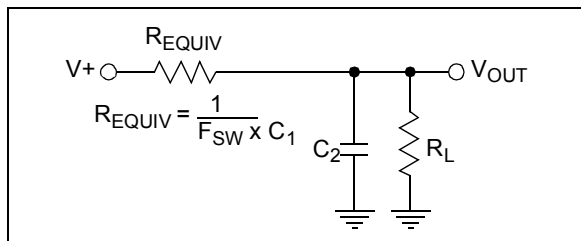

FIGURE 5-2: Equivalent Output Resistance.

5.3 Capacitor Selection

In order to maintain the lowest output resistance and output ripple voltage, it is recommended that low ESR capacitors be used. Additionally, larger values of C_1 will lower the output resistance and larger values of C_2 will reduce output ripple (see Equation 5-1b).

Table 5-1 shows various values of C_1 and the corresponding output resistance values @ +25°C. It assumes a 0.1Ω ESR_{C_1} and 0.9Ω R_{SW} . Table 5-2 shows the output voltage ripple for various values of C_2 . The V_{RIPPLE} values assume 5mA output load current and 0.1Ω ESR_{C_2} .

TABLE 5-1: OUTPUT RESISTANCE VS. C_1 (ESR = 0.1Ω)

C_1 (μF)	TC1240 $R_{OUT}(\Omega)$	TC1240A $R_{OUT}(\Omega)$
0.47	47	35
1	28.5	20.5
2.2	19.5	14
3.3	17	12
4.7	15.5	10.5
10	13.6	9.3
47	12.5	8.3
100	12.2	8.1

TABLE 5-2: OUTPUT VOLTAGE RIPPLE VS. C_2 (ESR = 0.1Ω) I_{OUT} 5 mA

C_1 (μF)	TC1240/TC1240A V_{RIPPLE} (mV)
0.47	142
1	67
2.2	30
3.3	20
4.7	14
10	6.7
47	2.5
100	1.6

5.4 Input Supply Bypassing

The V_{IN} input should be capacitively bypassed to reduce AC impedance and minimize noise effects due to the switching internal to the device. The recommended capacitor should be a large value (at least equal to C_1) connected from the input to GND.

5.5 Shutdown Input

The TC1240 and TC1240A are disabled when SHDN is high, and enabled when SHDN is low. This input cannot be allowed to float.

5.6 Voltage Doubler

The most common application for charge pump devices is the doubler (Figure 5-3). This application uses two external capacitors – C_1 and C_2 (plus a power supply bypass capacitor, if necessary). The output is equal to $2 \times V_{IN}$ minus any voltage drops due to loading. Refer to Table 5-1 and Table 5-2 for capacitor selection.

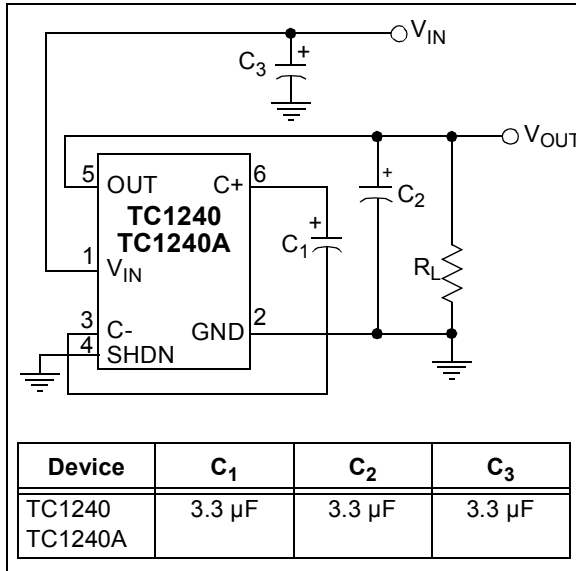

FIGURE 5-3: Test Circuit.

TC1240/TC1240A

5.7 Cascading Devices

Two or more TC1240/TC1240As can be cascaded to increase output voltage (Figure 5-4). If the output is lightly loaded, it will be close to $((n + 1) \times V_{IN})$, but will droop at least by R_{OUT} of the first device multiplied by the I_Q of the second. It can be seen that the output resistance rises rapidly for multiple cascaded devices. For the case of the two-stage 'tripler', output resistance can be approximated as $R_{OUT} = 2 \times R_{OUT1} + R_{OUT2}$, where R_{OUT1} is the output resistance of the first stage and R_{OUT2} is the output resistance of the second stage.

5.8 Paralleling Devices

To reduce the value of R_{OUT} , multiple TC1240/TC1240As can be connected in parallel (Figure 5-5). The output resistance will be reduced by a factor of N , where N is the number of TC1240/TC1240As. Each device will require its own pump capacitor (C_{1x}), but all devices may share one reservoir capacitor (C_2). However, to preserve ripple performance, the value of C_2 should be scaled according to the number of paralleled TC1240/TC1240As, respectively.

5.9 Layout Considerations

As with any switching power supply circuit good layout practice is recommended. Mount components as close together as possible to minimize stray inductance and capacitance. Also use a large ground plane to minimize noise leakage into other circuitry.

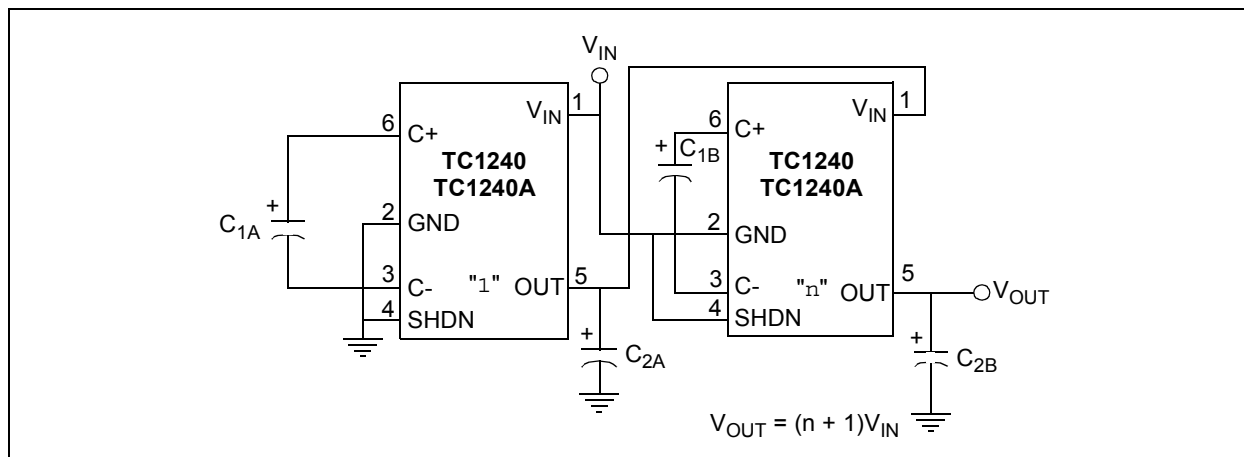

FIGURE 5-4: Cascading Multiple Devices To Increase Output Voltage.

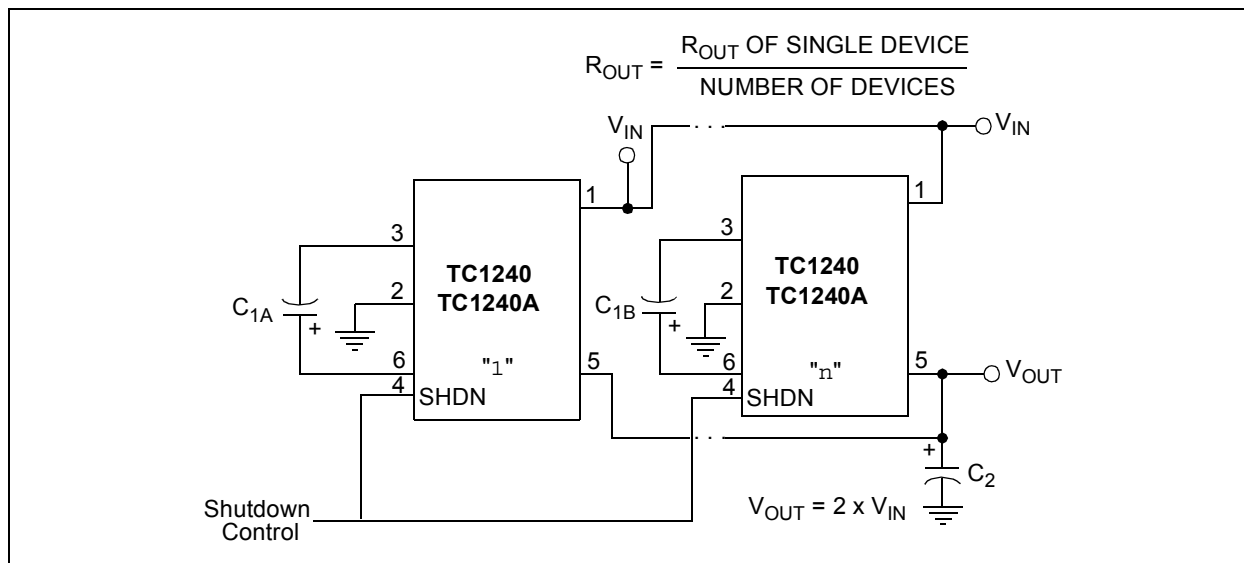
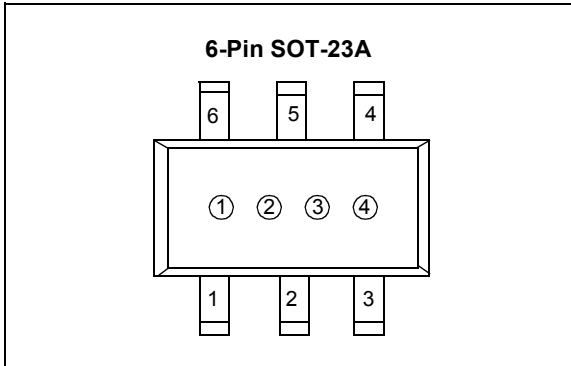

FIGURE 5-5: Paralleling Multiple Devices To Reduce Output Resistance.

6.0 PACKAGING INFORMATION

6.1 Package Marking Information



① & ② = part number code + temperature range
(two-digit code)

Device	Code
TC1240	DN
TC1240A	EN

ex: 1240AECH = ① ② ③ ④

③ represents year and 2-month code

④ represents production lot ID code

TC1240/TC1240A

6-Lead Plastic Small Outline Transistor (CH) (SOT-23)

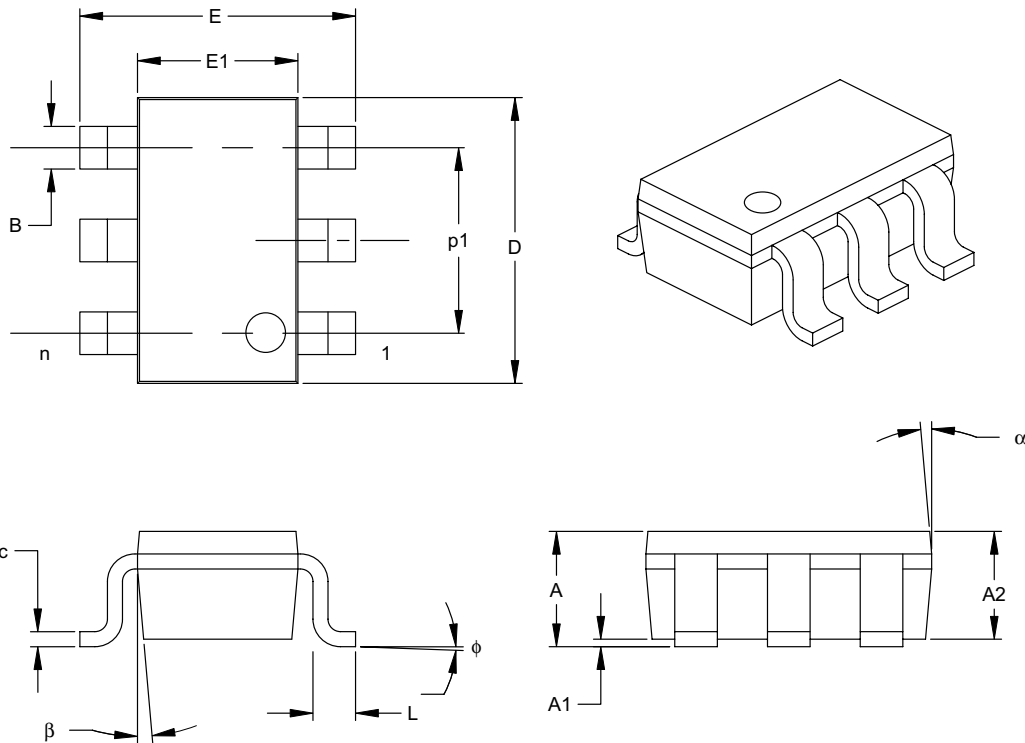

Dimension Limits	Units	INCHES*			MILLIMETERS		
		MIN	NOM	MAX	MIN	NOM	MAX
Number of Pins	n		6			6	
Pitch	p		.038			0.95	
Outside lead pitch (basic)	p1		.075			1.90	
Overall Height	A	.035	.046	.057	0.90	1.18	1.45
Molded Package Thickness	A2	.035	.043	.051	0.90	1.10	1.30
Standoff	A1	.000	.003	.006	0.00	0.08	0.15
Overall Width	E	.102	.110	.118	2.60	2.80	3.00
Molded Package Width	E1	.059	.064	.069	1.50	1.63	1.75
Overall Length	D	.110	.116	.122	2.80	2.95	3.10
Foot Length	L	.014	.018	.022	0.35	0.45	0.55
Foot Angle	φ	0	5	10	0	5	10
Lead Thickness	c	.004	.006	.008	0.09	0.15	0.20
Lead Width	B	.014	.017	.020	0.35	0.43	0.50
Mold Draft Angle Top	α	0	5	10	0	5	10
Mold Draft Angle Bottom	β	0	5	10	0	5	10

*Controlling Parameter

Notes:

Dimensions D and E1 do not include mold flash or protrusions. Mold flash or protrusions shall not exceed .005" (0.127mm) per side.

JEITA (formerly EIAJ) equivalent: SC-74A

Drawing No. C04-120

PRODUCT IDENTIFICATION SYSTEM

To order or obtain information, e.g., on pricing or delivery, refer to the factory or the listed sales office.

<u>PART NO.</u>	<u>X</u>	<u>/XX</u>
Device	Temperature Range	Package
Device	TC1240: Positive Doubling Charge Pump with Shutdown TC1240A Positive Doubling Charge Pump with Shutdown	
Temperature Range	I = -40°C to +85°C (Industrial)	
Package	CHTR: = 6L SOT-23, Tape and Reel	

Examples:

- a) TC1240ECHTR: Tape and Reel, 6L SOT-23 (EIAJ)
- b) TC1240AECHTR: Tape and Reel, 6L SOT-23 (EIAJ)

Sales and Support

Data Sheets

Products supported by a preliminary Data Sheet may have an errata sheet describing minor operational differences and recommended workarounds. To determine if an errata sheet exists for a particular device, please contact one of the following:

1. Your local Microchip sales office
2. The Microchip Corporate Literature Center U.S. FAX: (480) 792-7277
3. The Microchip Worldwide Site (www.microchip.com)

Please specify which device, revision of silicon and Data Sheet (include Literature #) you are using.

Customer Notification System

Register on our web site (www.microchip.com/cn) to receive the most current information on our products.

TC1240/TC1240A

NOTES:

Note the following details of the code protection feature on Microchip devices:

- Microchip products meet the specification contained in their particular Microchip Data Sheet.
- Microchip believes that its family of products is one of the most secure families of its kind on the market today, when used in the intended manner and under normal conditions.
- There are dishonest and possibly illegal methods used to breach the code protection feature. All of these methods, to our knowledge, require using the Microchip products in a manner outside the operating specifications contained in Microchip's Data Sheets. Most likely, the person doing so is engaged in theft of intellectual property.
- Microchip is willing to work with the customer who is concerned about the integrity of their code.
- Neither Microchip nor any other semiconductor manufacturer can guarantee the security of their code. Code protection does not mean that we are guaranteeing the product as "unbreakable."

Code protection is constantly evolving. We at Microchip are committed to continuously improving the code protection features of our products. Attempts to break microchip's code protection feature may be a violation of the Digital Millennium Copyright Act. If such acts allow unauthorized access to your software or other copyrighted work, you may have a right to sue for relief under that Act.

Information contained in this publication regarding device applications and the like is intended through suggestion only and may be superseded by updates. It is your responsibility to ensure that your application meets with your specifications. No representation or warranty is given and no liability is assumed by Microchip Technology Incorporated with respect to the accuracy or use of such information, or infringement of patents or other intellectual property rights arising from such use or otherwise. Use of Microchip's products as critical components in life support systems is not authorized except with express written approval by Microchip. No licenses are conveyed, implicitly or otherwise, under any intellectual property rights.

Trademarks

The Microchip name and logo, the Microchip logo, KEELOQ, MPLAB, PIC, PICmicro, PICSTART, PRO MATE and PowerSmart are registered trademarks of Microchip Technology Incorporated in the U.S.A. and other countries.

FilterLab, microID, MXDEV, MXLAB, PICMASTER, SEEVAL and The Embedded Control Solutions Company are registered trademarks of Microchip Technology Incorporated in the U.S.A.

Accuron, Application Maestro, dsPIC, dsPICDEM, dsPICDEM.net, ECONOMONITOR, FanSense, FlexROM, fuzzyLAB, In-Circuit Serial Programming, ICSP, ICEPIC, microPort, Migratable Memory, MPASM, MPLIB, MPLINK, MPSIM, PICC, PICkit, PICDEM, PICDEM.net, PowerCal, PowerInfo, PowerMate, PowerTool, rLAB, rPIC, Select Mode, SmartSensor, SmartShunt, SmartTel and Total Endurance are trademarks of Microchip Technology Incorporated in the U.S.A. and other countries.

Serialized Quick Turn Programming (SQTP) is a service mark of Microchip Technology Incorporated in the U.S.A.

All other trademarks mentioned herein are property of their respective companies.

© 2003, Microchip Technology Incorporated, Printed in the U.S.A., All Rights Reserved.

 Printed on recycled paper.



Microchip received QS-9000 quality system certification for its worldwide headquarters, design and wafer fabrication facilities in Chandler and Tempe, Arizona in July 1999 and Mountain View, California in March 2002. The Company's quality system processes and procedures are QS-9000 compliant for its PICmicro® 8-bit MCUs, KEELOQ® code hopping devices, Serial EEPROMs, microperipherals, non-volatile memory and analog products. In addition, Microchip's quality system for the design and manufacture of development systems is ISO 9001 certified.



WORLDWIDE SALES AND SERVICE

AMERICAS

Corporate Office

2355 West Chandler Blvd.
Chandler, AZ 85224-6199
Tel: 480-792-7200 Fax: 480-792-7277
Technical Support: 480-792-7627
Web Address: <http://www.microchip.com>

Atlanta

3780 Mansell Road, Suite 130
Alpharetta, GA 30022
Tel: 770-640-0034 Fax: 770-640-0307

Boston

2 Lan Drive, Suite 120
Westford, MA 01886
Tel: 978-692-3848 Fax: 978-692-3821

Chicago

333 Pierce Road, Suite 180
Itasca, IL 60143
Tel: 630-285-0071 Fax: 630-285-0075

Dallas

4570 Westgrove Drive, Suite 160
Addison, TX 75001
Tel: 972-818-7423 Fax: 972-818-2924

Detroit

Tri-Atria Office Building
32255 Northwestern Highway, Suite 190
Farmington Hills, MI 48334
Tel: 248-538-2250 Fax: 248-538-2260

Kokomo

2767 S. Albright Road
Kokomo, IN 46902
Tel: 765-864-8360 Fax: 765-864-8387

Los Angeles

18201 Von Karman, Suite 1090
Irvine, CA 92612
Tel: 949-263-1888 Fax: 949-263-1338

Phoenix

2355 West Chandler Blvd.
Chandler, AZ 85224-6199
Tel: 480-792-7966 Fax: 480-792-4338

San Jose

Microchip Technology Inc.
2107 North First Street, Suite 590
San Jose, CA 95131
Tel: 408-436-7950 Fax: 408-436-7955

Toronto

6285 Northam Drive, Suite 108
Mississauga, Ontario L4V 1X5, Canada
Tel: 905-673-0699 Fax: 905-673-6509

ASIA/PACIFIC

Australia

Microchip Technology Australia Pty Ltd
Marketing Support Division
Suite 22, 41 Rawson Street
Epping 2121, NSW
Australia
Tel: 61-2-9868-6733 Fax: 61-2-9868-6755

China - Beijing

Microchip Technology Consulting (Shanghai)
Co., Ltd., Beijing Liaison Office
Unit 915
Bei Hai Wan Tai Bldg.
No. 6 Chaoyangmen Beidajie
Beijing, 100027, No. China
Tel: 86-10-85282100 Fax: 86-10-85282104

China - Chengdu

Microchip Technology Consulting (Shanghai)
Co., Ltd., Chengdu Liaison Office
Rm. 2401-2402, 24th Floor,
Ming Xing Financial Tower
No. 88 TIDU Street
Chengdu 610016, China
Tel: 86-28-86766200 Fax: 86-28-86766599

China - Fuzhou

Microchip Technology Consulting (Shanghai)
Co., Ltd., Fuzhou Liaison Office
Unit 28F, World Trade Plaza
No. 71 Wusi Road
Fuzhou 350001, China
Tel: 86-591-7503506 Fax: 86-591-7503521

China - Hong Kong SAR

Microchip Technology Hongkong Ltd.
Unit 901-6, Tower 2, Metroplaza
223 Hing Fong Road
Kwai Fong, N.T., Hong Kong
Tel: 852-2401-1200 Fax: 852-2401-3431

China - Shanghai

Microchip Technology Consulting (Shanghai)
Co., Ltd.
Room 701, Bldg. B
Far East International Plaza
No. 317 Xian Xia Road
Shanghai, 200051
Tel: 86-21-6275-5700 Fax: 86-21-6275-5060

China - Shenzhen

Microchip Technology Consulting (Shanghai)
Co., Ltd., Shenzhen Liaison Office
Rm. 1812, 18/F, Building A, United Plaza
No. 5022 Binhe Road, Futian District
Shenzhen 518033, China
Tel: 86-755-82901380 Fax: 86-755-82966626

China - Qingdao

Rm. B505A, Fullhope Plaza,
No. 12 Hong Kong Central Rd.
Qingdao 266071, China
Tel: 86-532-5027355 Fax: 86-532-5027205

India

Microchip Technology Inc.
India Liaison Office
Marketing Support Division
Divyasree Chambers
1 Floor, Wing A (A3/A4)
No. 11, O'Shaughnessey Road
Bangalore, 560 025, India
Tel: 91-80-2290061 Fax: 91-80-2290062

Japan

Microchip Technology Japan K.K.
Benex S-1 6F
3-18-20, Shinyokohama
Kohoku-Ku, Yokohama-shi
Kanagawa, 222-0033, Japan
Tel: 81-45-471-6166 Fax: 81-45-471-6122

Korea

Microchip Technology Korea
168-1, Youngbo Bldg. 3 Floor
Samsung-Dong, Kangnam-Ku
Seoul, Korea 135-882
Tel: 82-2-554-7200 Fax: 82-2-558-5934

Singapore

Microchip Technology Singapore Pte Ltd.
200 Middle Road
#07-02 Prime Centre
Singapore, 188980
Tel: 65-6334-8870 Fax: 65-6334-8850

Taiwan

Microchip Technology (Barbados) Inc.,
Taiwan Branch
11F-3, No. 207
Tung Hua North Road
Taipei, 105, Taiwan
Tel: 886-2-2717-7175 Fax: 886-2-2545-0139

EUROPE

Austria

Microchip Technology Austria GmbH
Durisolstrasse 2
A-4600 Wels
Austria
Tel: 43-7242-2244-399
Fax: 43-7242-2244-393

Denmark

Microchip Technology Nordic ApS
Regus Business Centre
Lautrup høj 1-3
Ballerup DK-2750 Denmark
Tel: 45-4420-9895 Fax: 45-4420-9910

France

Microchip Technology SARL
Parc d'Activite du Moulin de Massy
43 Rue du Saule Trapu
Batiment A - ler Etage
91300 Massy, France
Tel: 33-1-69-53-63-20 Fax: 33-1-69-30-90-79

Germany

Microchip Technology GmbH
Steinheilstrasse 10
D-85737 Ismaning, Germany
Tel: 49-89-627-144-0
Fax: 49-89-627-144-44

Italy

Microchip Technology SRL
Via Quasimodo, 12
20025 Legnano (MI)
Milan, Italy
Tel: 39-0331-742611 Fax: 39-0331-466781

United Kingdom

Microchip Ltd.
505 Eskdale Road
Winnersh Triangle
Wokingham
Berkshire, England RG41 5TU
Tel: 44-118-921-5869 Fax: 44-118-921-5820

03/25/03