

300mA CMOS LDO with Shutdown, ERROR Output and Bypass

FEATURES

- Extremely Low Supply Current for Longer Battery Life!
- Very Low Dropout Voltage
- Guaranteed 300mA Output
- Standard or Custom Output Voltages
- $\overline{\text{ERROR}}$ Output Can be Used as a Low Battery Detector or Processor Reset Generator
- Power-Saving Shutdown Mode
- Bypass Input for Ultra-Quiet Operation
- Over-Current and Over-Temperature Protection
- Space-Saving MSOP Package Option

APPLICATIONS

- Battery-Operated Systems
- Portable Computers
- Medical Instruments
- Instrumentation
- Cellular / GSM / PHS Phones
- Linear Post-Regulator for SMPS
- Pagers

TYPICAL APPLICATION

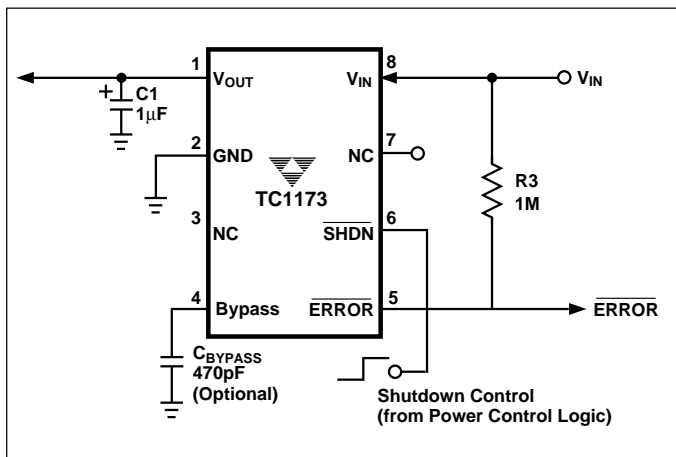

GENERAL DESCRIPTION

The TC1173 is a precision output (typically $\pm 0.5\%$) CMOS low dropout regulator. Total supply current is typically $50\mu\text{A}$ at full load (*20 to 60 times lower than in bipolar regulators!*).

TC1173 key features include ultra low noise operation (plus optional Bypass input); very low dropout voltage (typically 240mV at full load) and internal feed-forward compensation for fast response to step changes in load. An error output (ERROR) is asserted when the TC1173 is out-of-regulation (due to a low input voltage or excessive output current). ERROR can be set as a low battery warning or as a processor RESET signal (with the addition of an external RC network). Supply current is reduced to $0.05\mu\text{A}$ (typical) and V_{OUT} and ERROR fall to zero when the shutdown input is low.

The TC1173 incorporates both over-temperature and over-current protection. The TC1173 is stable with an output capacitor of only $1\mu\text{F}$ and has a maximum output current of 300mA .

ORDERING INFORMATION

Part Number	Package	Junction Temp. Range
TC1173-xxVOA	8-Pin SOIC	-40°C to $+125^{\circ}\text{C}$
TC1173-xxVUA	8-Pin MSOP	-40°C to $+125^{\circ}\text{C}$

Available Output Voltages:

2.5, 2.8, 3.0, 3.3, 5.0

xx indicates output voltages

Other output voltages are available. Please contact TelCom Semiconductor for details.

PIN CONFIGURATION

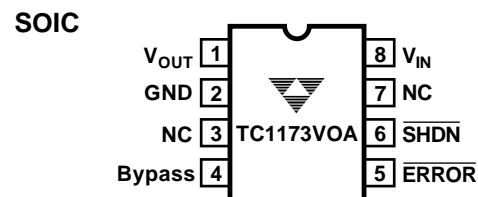
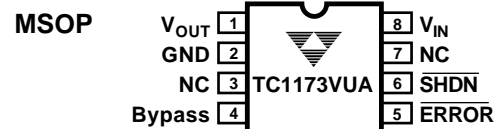

300mA CMOS LDO With Shutdown, ERROR Output, And Bypass

TC1173

ABSOLUTE MAXIMUM RATINGS*

Input Voltage	6.5V
Output Voltage	(V _{SS} – 0.3) to (V _{IN} + 0.3)
Power Dissipation	Internally Limited (Note 7)
Operating Temperature	– 40°C < T _J < 125°C

Storage Temperature	– 65°C to +150°C
Maximum Voltage on Any Pin	V _{IN} +0.3V to – 0.3V
Lead Temperature (Soldering, 10 Sec.)	+300°C

*Absolute Maximum Ratings indicate device operation limits beyond damage may occur. Device operation beyond the limits listed in *Electrical Characteristics* is not recommended.

ELECTRICAL CHARACTERISTICS: V_{IN} = V_{OUT} + 1V, I_L = 0.1mA, C_L = 3.3μF, $\overline{\text{SHDN}} > V_{IH}$, T_A = 25°C, unless otherwise noted.
BOLDFACE type specifications apply for junction temperatures of – 40°C to +125°C

Symbol	Parameter	Test Conditions	Min	Typ	Max	Units
V _{IN}	Input Operating Voltage		—	—	6.0	V
I _{OUTMAX}	Maximum Output Current		300	—	—	mA
V _{OUT}	Output Voltage	Note 1	— V_R - 2.5%	V _R ± 0.5%	— V_R + 2.5%	V
ΔV _{OUT} /ΔT	V _{OUT} Temperature Coefficient	Note 2	—	— 40	—	ppm/°C
ΔV _{OUT} /ΔV _{IN}	Line Regulation	(V _R + 1V) ≤ V _{IN} ≤ 6V	—	0.05	0.35	%
ΔV _{OUT} /V _{OUT}	Load Regulation	I _L = 0.1mA to I _{OUTMAX} (Note 3)	—	0.5	2.0	%
V _{IN} – V _{OUT}	Dropout Voltage (Note 4)	I _L = 0.1mA I _L = 100mA I _L = 300mA	—	20 80 240	30 160 480	mV
I _{SS1}	Supply Current	SHDN = V _{IH}	—	50	90	μA
I _{SS2}	Shutdown Supply Current	SHDN = 0V	—	0.05	0.5	μA
PSRR	Power Supply Rejection Ratio	F _{RE} ≤ 1kHz	—	60	—	dB
I _{OUTSC}	Output Short Circuit Current	V _{OUT} = 0V	—	550	650	mA
ΔV _{OUT} ΔP _D	Thermal Regulation	Note 5	—	0.04	—	V/W
eN	Output Noise	F = 1kHz, C _{OUT} = 1μF, R _{LOAD} = 50Ω	—	260	—	nV/√Hz

SHDN Input

V _{IH}	SHDN Input High Threshold	45	—	—	%V _{IN}
V _{IL}	SHDN Input Low Threshold	—	—	15	%V _{IN}

ERROR Output

V _{MIN}	Minimum Operating Voltage	1.0	—	—	V	
V _{OL}	Output Logic Low Voltage	1mA Flows to ERROR	—	—	400	mV
V _{TH}	ERROR Threshold Voltage		—	0.95 x V _R	V	
V _{OL}	ERROR Positive Hysteresis	Note 7	—	50	mV	

NOTES: 1. V_R is the user-programmed regulator output voltage setting.

$$2. T_C V_{OUT} = \frac{(V_{OUTMAX} - V_{OUTMIN}) \times 10^6}{V_{OUT} \times \Delta T}$$

- Regulation is measured at a constant junction temperature using low duty cycle pulse testing. Load regulation is tested over a load range from 0.1mA to the maximum specified output current. Changes in output voltage due to heating effects are covered by the thermal regulation specification.
- Dropout voltage is defined as the input to output differential at which the output voltage drops 2% below its nominal value measured at a 1V differential.
- Thermal Regulation is defined as the change in output voltage at a time T after a change in power dissipation is applied, excluding load or line regulation effects. Specifications are for a current pulse equal to I_{LMAX} at V_{IN} = 6V for T = 10msec.
- The maximum allowable power dissipation is a function of ambient temperature, the maximum allowable junction temperature, and the thermal resistance from junction-to-air (i.e. T_A, T_J, θ_{JA}). Exceeding the maximum allowable power dissipation causes the device to initiate thermal shutdown. Please see *Thermal Considerations* section of this data sheet for more details.
- Hysteresis voltage is referenced to V_R.

300mA CMOS LDO With Shutdown, ERROR Output, And Bypass

TC1173

DETAILED DESCRIPTION

The TC1173 is a fixed output, low drop-out regulator. Unlike bipolar regulators, the TC1173 supply current does not increase with load current. In addition, V_{OUT} remains stable and within regulation at very low load currents (an important consideration in RTC and CMOS RAM battery back-up applications). TC1173 pin functions are detailed below:

PIN DESCRIPTIONS

Pin No.	Symbol	Description
1	V_{OUT}	Regulated voltage output
2	GND	Ground terminal
3	NC	No connect
4	Bypass	Reference bypass input. Connecting a 470pF to this input further reduces output noise.
5	ERROR	Out-of-Regulation Flag (Open Drain Output). This output goes low when V_{OUT} is out-of-tolerance by approximately -5%.
6	SHDN	Shutdown control input. The regulator is fully enabled when a logic high is applied to this input. The regulator enters shutdown when a logic low is applied to this input. During shutdown, output voltage falls to zero and supply current is reduced to 0.05 μ A (typical).
7	NC	No connect
8	V_{IN}	Unregulated supply input

Figure 1 shows a typical application circuit. The regulator is enabled any time the shutdown input (SHDN) is above V_{IH} , and shutdown (disabled) when SHDN is at or below V_{IL} .

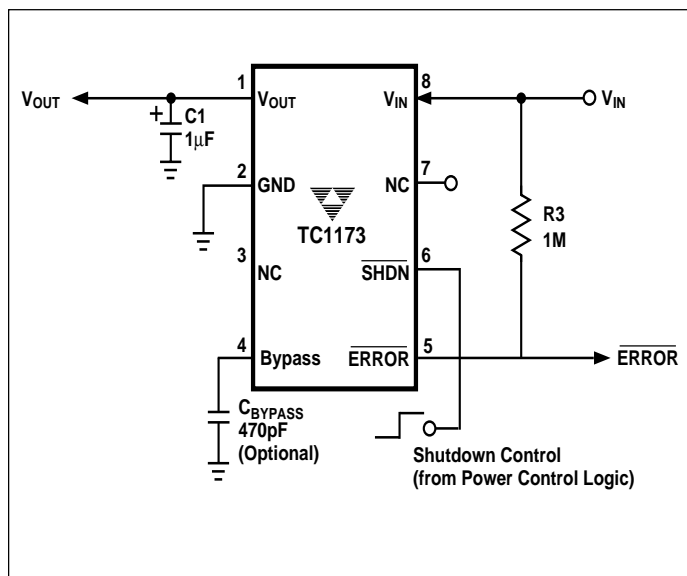

Figure 1: Typical Application Circuit

SHDN may be controlled by a CMOS logic gate, or I/O port of a microcontroller. If the SHDN input is not required, it should be connected directly to the input supply. While in shutdown, supply current decreases to 0.05 μ A (typical), V_{OUT} falls to zero and ERROR is disabled.

ERROR Output

ERROR is driven low whenever V_{OUT} falls out of regulation by more than -5% (typical). This condition may be caused by low input voltage, output current limiting, or thermal limiting.

The ERROR threshold is 5% below rated V_{OUT} regardless of the programmed output voltage value (e.g., ERROR = V_{OL} at 4.75V (typ) for a 5.0V regulator and 2.85V (typ) for a 3.0V regulator). ERROR output operation is shown in Figure 2. Note that ERROR is active when V_{OUT} is at or below V_{TH} , and inactive when V_{OUT} is above $V_{TH} + V_H$.

As shown in Figure 1, ERROR can be used as a battery low flag, or as a processor RESET signal (with the addition of timing capacitor C2). R1 x C3 should be chosen to maintain ERROR below V_{IH} of the processor RESET input for at least 200msec to allow time for the system to stabilize. Pull-up resistor R1 can be tied to V_{OUT} , V_{IN} or any other voltage less than ($V_{IN} + 0.3V$.)

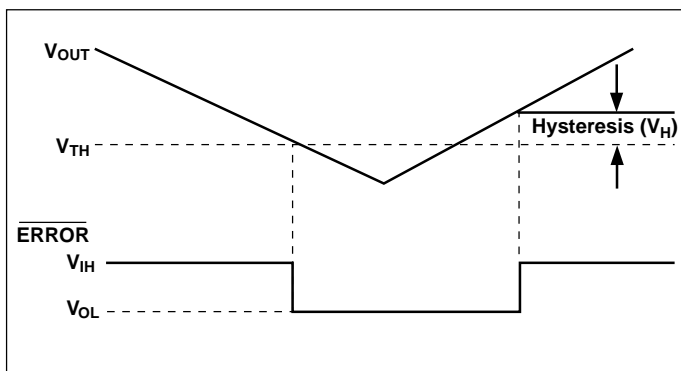

Figure 2: ERROR Output Operation

Output Capacitor

A 1 μ F (min) capacitor from V_{OUT} to ground is recommended. The output capacitor should have an effective series resistance of 5 Ω or less. A 1 μ F capacitor should be connected from V_{IN} to GND if there is more than 10 inches of wire between the regulator and the AC filter capacitor, or if a battery is used as the power source. Aluminum electrolytic or tantalum capacitor types can be used. (Since many aluminum electrolytic capacitors freeze at approximately -30 $^{\circ}$ C, solid tantalums are recommended for applications operating below -25 $^{\circ}$ C.) When operating from sources other than batteries, supply-noise rejection and transient response can be improved by increasing the value of the input and output capacitors and employing passive filtering techniques.

TC1173

Bypass Input

A 470pF capacitor connected from the Bypass input to ground reduces noise present on the internal reference, which in turn significantly reduces output noise. If output noise is not a concern, this input may be left unconnected. Larger capacitor values may be used, but results in a longer time period to rated output voltage when power is initially applied.

Thermal Considerations

Thermal Shutdown

Integrated thermal protection circuitry shuts the regulator off when die temperature exceeds 150°C. The regulator remains off until the die temperature drops to approximately 140°C.

Power Dissipation

The amount of power the regulator dissipates is primarily a function of input and output voltage, and output current. The following equation is used to calculate worst case *actual* power dissipation:

$$P_D \approx (V_{INMAX} - V_{OUTMIN})I_{LOADMAX}$$

Where: P_D = worst case actual power dissipation
 V_{INMAX} = maximum voltage on V_{IN}
 V_{OUTMIN} = minimum regulator output voltage
 $I_{LOADMAX}$ = maximum output (load) current

Equation 1.

The maximum *allowable* power dissipation (Equation 2) is a function of the maximum ambient temperature (T_{AMAX}), the maximum allowable die temperature (125°C), and the thermal resistance from junction-to-air (θ_{JA}). The 8-Pin SOIC package has a θ_{JA} of approximately **160°C/Watt**, while the 8-Pin MSOP package has a θ_{JA} of approximately **200°C/Watt**; both when mounted on a single layer FR4 dielectric copper clad PC board.

$$P_{DMAX} = \frac{(T_{JMAX} - T_{AMAX})}{\theta_{JA}}$$

Where all terms are previously defined.

Equation 2.

Equation 1 can be used in conjunction with Equation 2 to ensure regulator thermal operation is within limits. For example:

GIVEN: $V_{INMAX} = 3.0V \pm 10\%$
 $V_{OUTMIN} = 2.7V \pm 0.5\%$
 $I_{LOADMAX} = 250mA$
 $T_{JMAX} = 125^\circ C$
 $T_{AMAX} = 55^\circ C$
 $\theta_{JA} = 200^\circ C/W$
 8-Pin MSOP Package

FIND: 1. Actual power dissipation
 2. Maximum allowable dissipation

Actual power dissipation:

$$\begin{aligned} P_D &\approx (V_{INMAX} - V_{OUTMIN})I_{LOADMAX} \\ &= [(3.0 \times 1.1) - (2.7 \times .995)]250 \times 10^{-3} \\ &= \underline{155mW} \end{aligned}$$

Maximum allowable power dissipation:

$$\begin{aligned} P_D &\approx \frac{(T_{JMAX} - T_{AMAX})}{\theta_{JA}} \\ &= \frac{(125 - 55)}{200} \\ &= \underline{350mW} \end{aligned}$$

In this example, the TC1173 dissipates a maximum of only 155mW; far below the allowable limit of 350mW. In a similar manner, Equation 1 and Equation 2 can be used to calculate maximum current and/or input voltage limits. For example, the maximum allowable V_{IN} is found by substituting the maximum allowable power dissipation of 350mW into Equation 1, from which $V_{INMAX} = 4.1V$.

Layout Considerations

The primary path of heat conduction out of the package is via the package leads. Therefore, layouts having a ground plane, wide traces at the pads, and wide power supply bus lines combine to lower θ_{JA} and, therefore, increase the maximum allowable power dissipation limit.

300mA CMOS LDO With Shutdown, ERROR Output, And Bypass

TC1173

TYPICAL CHARACTERISTICS

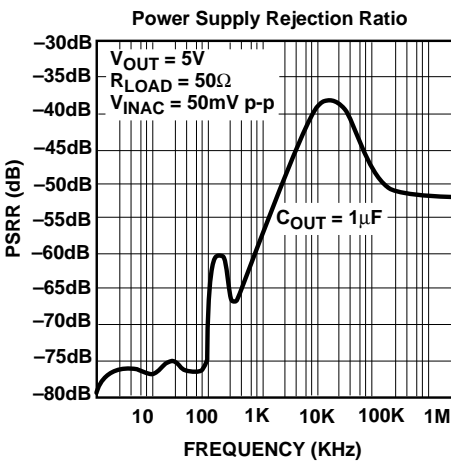
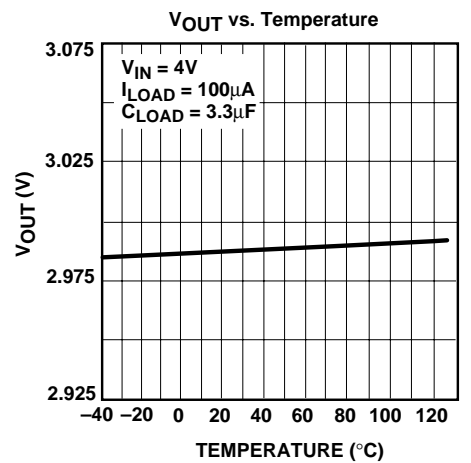
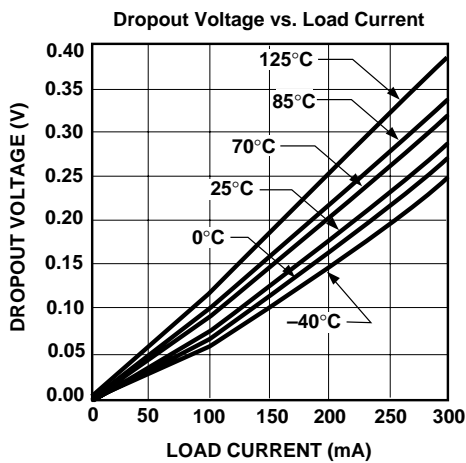
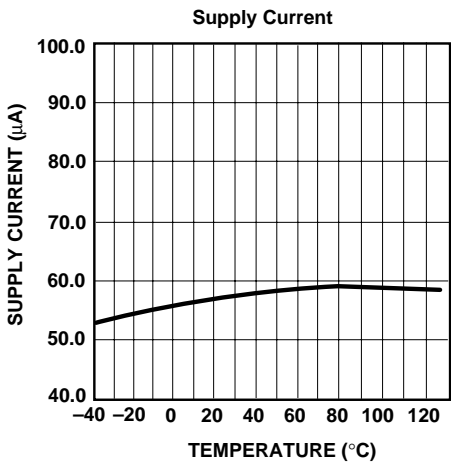
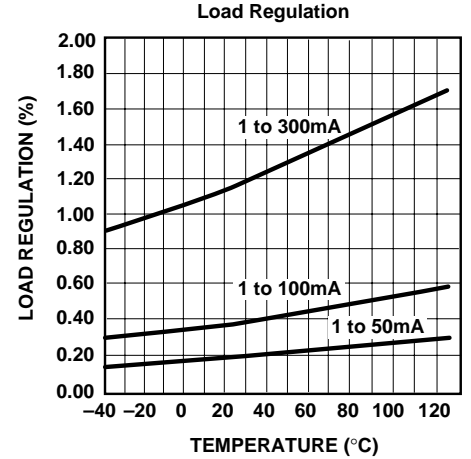
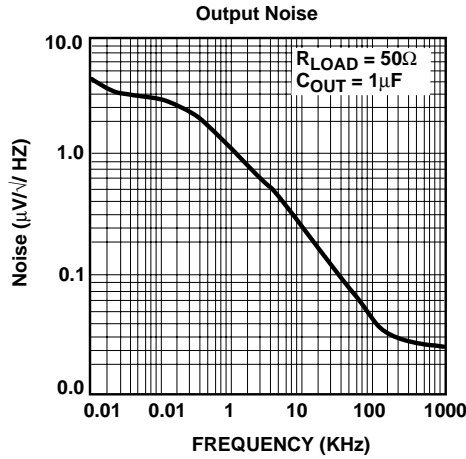
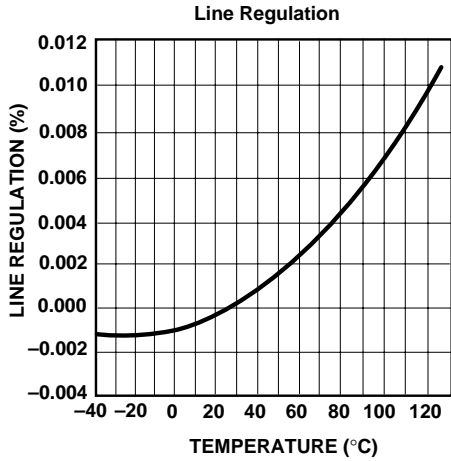

300mA CMOS LDO With Shutdown, ERROR Output, And Bypass

TC1173

TAPE AND REEL DIAGRAMS

Component Taping Orientation for 8-Pin SOIC (Narrow) Devices

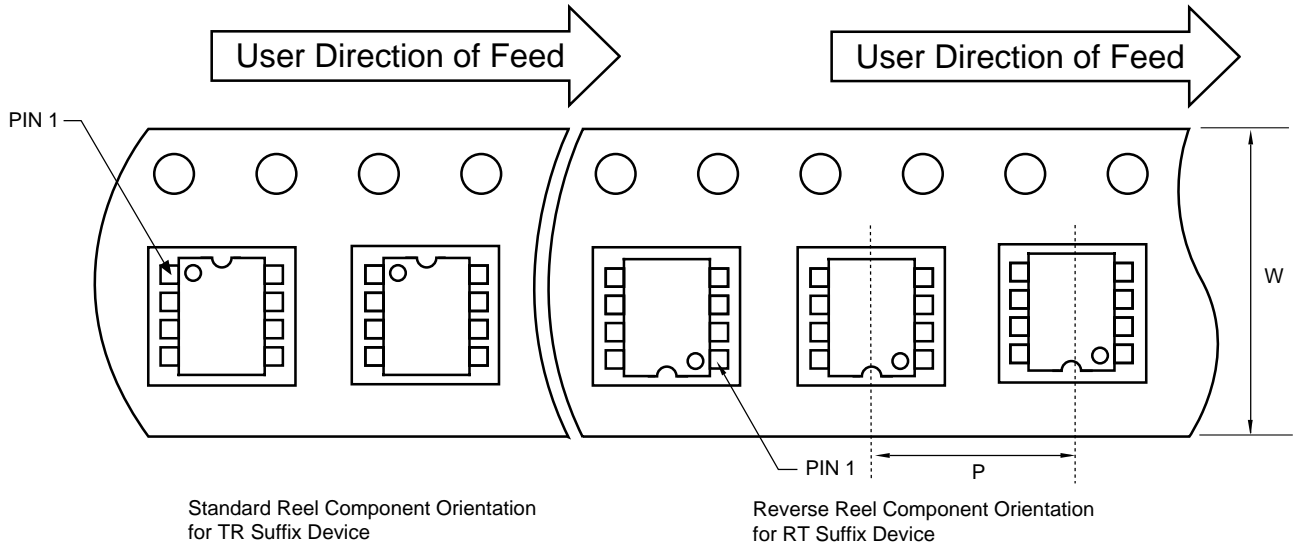

Carrier Tape, Number of Components Per Reel and Reel Size

Package	Carrier Width (W)	Pitch (P)	Part Per Full Reel	Reel Size
8-Pin SOIC (N)	12 mm	8 mm	2500	13 in

Component Taping Orientation for 8-Pin MSOP Devices

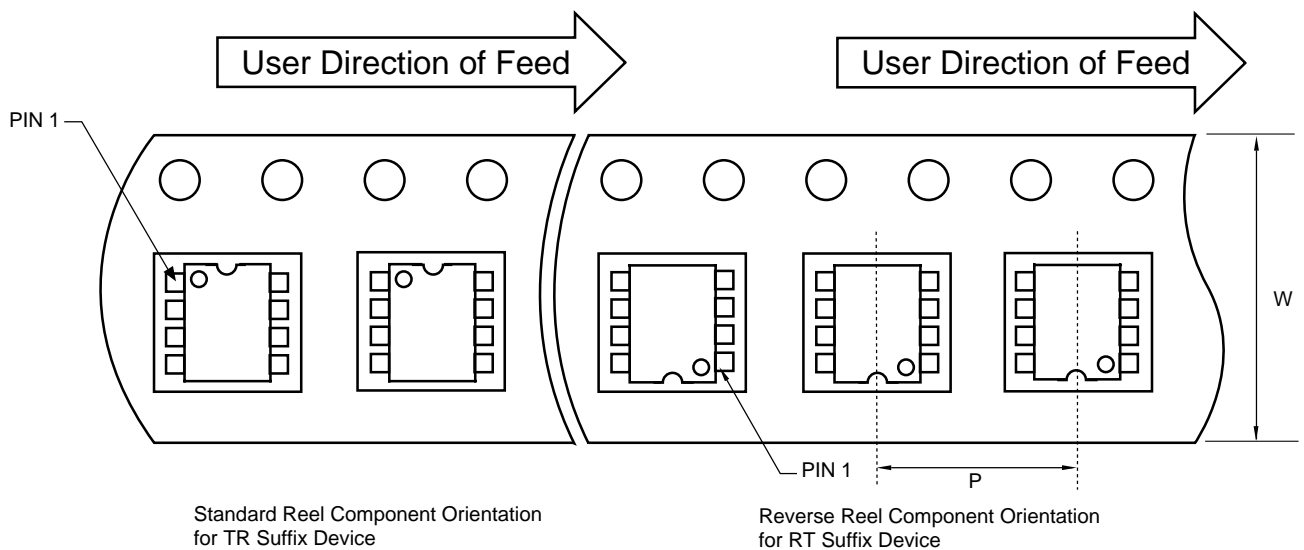

Carrier Tape, Number of Components Per Reel and Reel Size

Package	Carrier Width (W)	Pitch (P)	Part Per Full Reel	Reel Size
8-Pin MSOP	12 mm	8 mm	2500	13 in

300mA CMOS LDO With Shutdown, ERROR Output, And Bypass

TC1173

PACKAGE DIMENSIONS

8-Pin SOIC (Narrow)

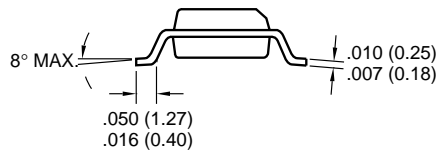
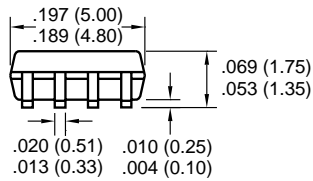
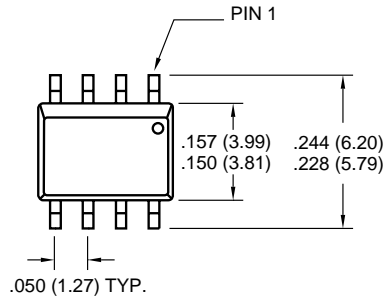

8-Pin MSOP

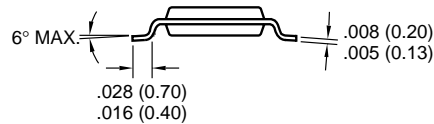
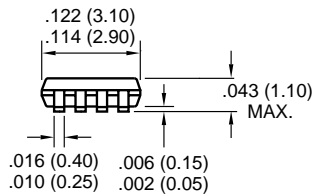
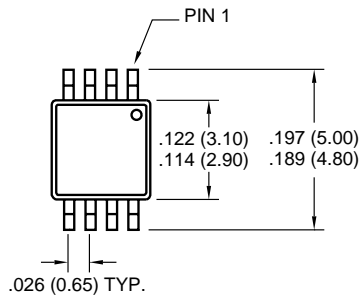

Dimensions: inches (mm)

Sales Offices

TelCom Semiconductor, Inc.
1300 Terra Bella Avenue
P.O. Box 7267
Mountain View, CA 94039-7267
TEL: 650-968-9241
FAX: 650-967-1590
E-Mail: liter@telcom-semi.com

TelCom Semiconductor, GmbH
Lochhamer Strasse 13
D-82152 Martinsried
Germany
TEL: (011) 49 89 895 6500
FAX: (011) 49 89 895 6502 2

TelCom Semiconductor H.K. Ltd.
10 Sam Chuk Street, Ground Floor
San Po Kong, Kowloon
Hong Kong
TEL: (011) 852-2350-7380
FAX: (011) 852-2354-9957