

PFM/PWM Step-Up DC/DC Controller

Features

- Assured Start-up at 0.9V
- 50µA (Typ) Supply Current ($f_{OSC} = 100\text{kHz}$)
- 300mA Output Current @ $V_{IN} \geq 2.7\text{V}$
- 0.5µA Shutdown Mode
- 100kHz and 300kHz Switching Frequency Options
- Programmable Soft-Start
- 84% Typical Efficiency
- Small Package: 5-Pin SOT-23A

Applications

- Palmtops
- Battery-Operated Systems
- Positive LCD Bias Generators
- Portable Communicators

Device Selection Table

Part Number	Output Voltage (V)*	Package	Osc. Freq. (kHz)	Operating Temp. Range
TC110501ECT	5.0	5-Pin SOT-23A	100	-40°C to +85°C
TC110331ECT	3.3	5-Pin SOT-23A	100	-40°C to +85°C
TC110301ECT	3.0	5-Pin SOT-23A	100	-40°C to +85°C
TC110503ECT	5.0	5-Pin SOT-23A	300	-40°C to +85°C
TC110333ECT	3.3	5-Pin SOT-23A	300	-40°C to +85°C
TC110303ECT	3.0	5-Pin SOT-23A	300	-40°C to +85°C

*Other output voltages are available. Please contact Microchip Technology Inc. for details.

Package Type

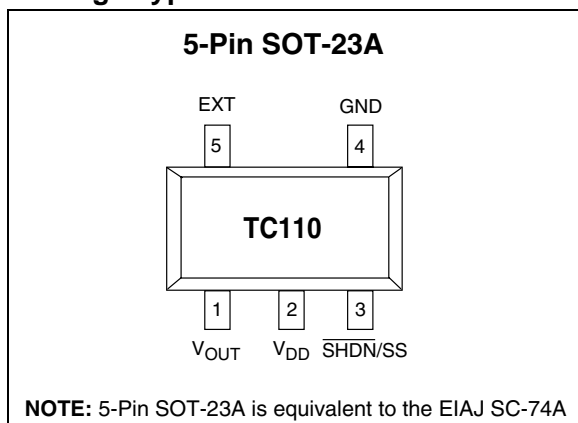

General Description

The TC110 is a step-up (Boost) switching controller that furnishes output currents of up to 300mA while delivering a typical efficiency of 84%. The TC110 normally operates in pulse width modulation mode (PWM), but automatically switches to pulse frequency modulation (PFM) at low output loads for greater efficiency. Supply current draw for the 100kHz version is typically only 50µA, and is reduced to less than 0.5µA when the SHDN input is brought low. Regulator operation is suspended during shutdown. The TC110 accepts input voltages from 2.0V to 10.0V, with a guaranteed start-up voltage of 0.9V.

The TC110 is available in a small 5-Pin SOT-23A package, occupies minimum board space and uses small external components (the 300kHz version allows for less than 5mm surface-mount magnetics).

Functional Block Diagram

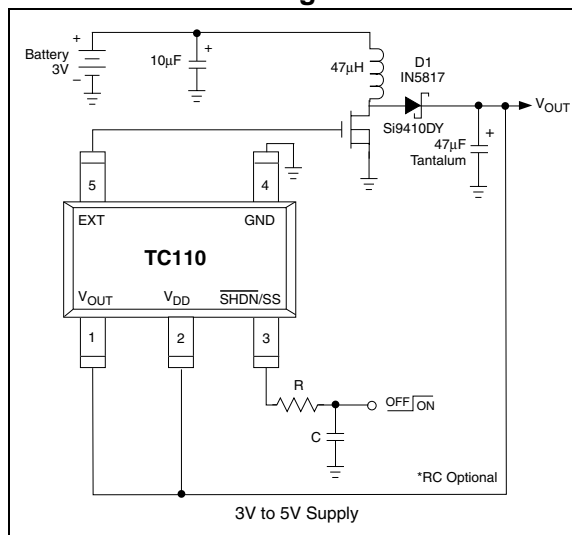

TC110

1.0 ELECTRICAL CHARACTERISTICS

Absolute Maximum Ratings*

Voltage on V_{DD} , V_{OUT} , \overline{SHDN} Pins -0.3V to +12V
 EXT Output Current $\pm 100\text{mA}$ pk
 Voltage on EXT Pin -0.3V to $V_{DD} + 0.3\text{V}$
 Power Dissipation 150mW
 Operating Temperature Range -40°C to +85°C
 Storage Temperature Range -40°C to +125°C

*Stresses above those listed under "Absolute Maximum Ratings" may cause permanent damage to the device. These are stress ratings only and functional operation of the device at these or any other conditions above those indicated in the operation sections of the specifications is not implied. Exposure to Absolute Maximum Rating conditions for extended periods may affect device reliability.

TC110 ELECTRICAL SPECIFICATIONS

Electrical Characteristics: Note 1, $V_{IN} = 0.6 \times V_R$, $V_{DD} = V_{OUT}$, $T_A = 25^\circ\text{C}$, unless otherwise noted.						
Symbol	Parameter	Min	Typ	Max	Units	Test Conditions
V_{DD}	Operating Supply Voltage	2.0	—	10.0	V	Note 2
V_{START}	Start-Up Supply Voltage	—	—	0.9	V	$I_{OUT} = 1\text{mA}$
$V_{HOLD-UP}$	Oscillator Hold-Up Voltage	—	—	0.7	V	$I_{OUT} = 1\text{mA}$
I_{DD}	Boost Mode Supply Current	—	120 130 180 50 50 70	190 200 280 90 100 120	μA	$V_{OUT} = \overline{SHDN} = (0.95 \times V_R)$; $f_{OSC} = 300\text{kHz}$; $V_R = 3.0\text{V}$ $V_R = 3.3\text{V}$ $V_R = 5.0\text{V}$ $f_{OSC} = 100\text{kHz}$; $V_R = 3.0\text{V}$ $V_R = 3.3\text{V}$ $V_R = 5.0\text{V}$
I_{STBY}	Standby Supply Current	—	20 20 22 11 11 11	34 35 38 20 20 22	μA	$V_{OUT} = \overline{SHDN} = (V_R + 0.5\text{V})$; $f_{OSC} = 300\text{kHz}$; $V_R = 3.0\text{V}$ $V_R = 3.3\text{V}$ $V_R = 5.0\text{V}$ $f_{OSC} = 100\text{kHz}$; $V_R = 3.0\text{V}$ $V_R = 3.3\text{V}$ $V_R = 5.0\text{V}$
I_{SHDN}	Shutdown Supply Current	—	0.05	0.5	μA	$\overline{SHDN} = \text{GND}$, $V_O = (V_R \times 0.95)$
f_{OSC}	Oscillator Frequency	255 85	300 100	345 115	kHz	$V_{OUT} = \overline{SHDN} = (0.95 \times V_R)$; $f_{OSC} = 300\text{kHz}$ $f_{OSC} = 100\text{kHz}$
V_{OUT}	Output Voltage	V_R $\times 0.975$	V_R	V_R $\times 1.025$	V	Note 3
DTYMAX	Maximum Duty Cycle (PWM Mode)	—	—	92	%	$V_{OUT} = \overline{SHDN} = 0.95 \times V_R$
DTYPFM	Duty Cycle (PFM Mode)	15	25	35	%	$I_{OUT} = 0\text{mA}$
V_{IH}	\overline{SHDN} Input Logic High	0.65	—	—	V	$V_{OUT} = (V_R \times 0.95)$
V_{IL}	\overline{SHDN} Input Logic Low	—	—	0.20	V	$V_{OUT} = (V_R \times 0.95)$
REXTH	EXT ON Resistance to V_{DD}	—	32 29 20	47 43 29	Ω	$V_{OUT} = \overline{SHDN} = (V_R \times 0.95)$; $V_R = 3.0\text{V}$ $V_R = 3.3\text{V}$ $V_R = 5.0\text{V}$ $V_{EXT} = (V_{OUT} - 0.4\text{V})$ $V_R = 5.0\text{V}$
REXTL	EXT ON Resistance to GND	—	20 19 13	30 27 19	Ω	$V_{OUT} = \overline{SHDN} = (V_R \times 0.95)$; $V_R = 3.0\text{V}$ $V_R = 3.3\text{V}$ $V_R = 5.0\text{V}$ $V_{EXT} = 0.4\text{V}$ $V_R = 5.0\text{V}$
η	Efficiency	—	84	—	%	

- Note 1:** $V_R = 3.0\text{V}$, $I_{OUT} = 120\text{mA}$
 $V_R = 3.3\text{V}$, $I_{OUT} = 130\text{mA}$
 $V_R = 5.0\text{V}$, $I_{OUT} = 200\text{mA}$
2: See Application Notes "Operating Mode" description for clarification.
3: V_R is the factory output voltage setting.

2.0 PIN DESCRIPTIONS

The descriptions of the pins are listed in Table 2-1.

TABLE 2-1: PIN FUNCTION TABLE

Pin No. (5-Pin SOT-23A)	Symbol	Description
1	V_{OUT}	Internal device power and voltage sense input. This dual function input provides both feedback voltage sensing and internal chip power. It should be connected to the regulator output. (See Section 4.0, Applications).
2	V_{DD}	Power supply voltage input.
3	$\overline{SHDN/SS}$	Shutdown input. A logic low on this input suspends device operation and supply current is reduced to less than 0.5 μ A. The device resumes normal operation when \overline{SHDN} is again brought high. An RC circuit connected to this input also determines the soft-start time.
4	GND	Ground terminal.
5	EXT	External switch transistor drive complimentary output. This pin drives the external switching transistor. It may be connected to the base of the external bipolar transistor or gate of the external N-channel MOSFET. (See Section 4.0, Applications).

3.0 DETAILED DESCRIPTION

The TC110 is a PFM/PWM step-up DC/DC controller for use in systems operating from two or more cells, or in low voltage, line-powered applications. It uses PWM as the primary modulation scheme, but automatically converts to PFM at output duty cycles less than approximately 25%. The conversion to PFM provides reduced supply current, and therefore higher operating efficiency at low loads. The TC110 uses an external switching transistor, allowing construction of switching regulators with maximum output currents of 300mA.

The TC110 consumes only 70 μ A, typical, of supply current and can be placed in a 0.5 μ A shutdown mode by bringing the shutdown input ($\overline{\text{SHDN}}$) low. The regulator remains disabled while in shutdown mode, and normal operation resumes when $\overline{\text{SHDN}}$ is brought high. Other features include start-up at $V_{\text{IN}} = 0.9\text{V}$ and an externally programmable soft start time.

3.1 Operating Mode

The TC110 is powered by the voltage present on the V_{DD} input. The applications circuits of Figure 3-1 and Figure 3-2 show operation in the bootstrapped and non-bootstrapped modes. In bootstrapped mode, the TC110 is powered from the output (start-up voltage is supplied by V_{IN} through the inductor and Schottky diode while Q1 is off). In bootstrapped mode, the switching transistor is turned on harder because its gate voltage is higher (due to the boost action of the regulator), resulting in higher output current capacity.

The TC110 is powered from the input supply in the non-bootstrapped mode. In this mode, the supply current to the TC110 is minimized. However, the drive applied to the gate of the switching transistor swings from the input supply level to ground, so the transistor's ON resistance increases at low input voltages. Overall efficiency is increased since supply current is reduced, and less energy is consumed charging and discharging the gate of the MOSFET. While the TC110 is guaranteed to start up at 0.9V the device performs to specifications at 2.0V and higher.

3.2 Low Power Shutdown Mode

The TC110 enters a low power shutdown mode when $\overline{\text{SHDN}}$ is brought low. While in shutdown, the oscillator is disabled and the output switch (internal or external) is shut off. Normal regulator operation resumes when $\overline{\text{SHDN}}$ is brought high. $\overline{\text{SHDN}}$ may be tied to the input supply if not used.

Note: Because the TC110 uses an external diode, a leakage path between the input voltage and the output node (through the inductor and diode) exists while the regulator is in shutdown. Care must be taken in system design to assure the input supply is isolated from the load during shutdown.

3.3 Soft Start

Soft start allows the output voltage to gradually ramp from 0V to rated output value during start-up. This action minimizes (or eliminates) overshoot, and in general, reduces stress on circuit components. Figure 3-3 shows the circuit required to implement soft start (values of 470K and 0.1 μ F for R_{SS} and C_{SS} , respectively, are adequate for most applications).

3.4 Input Bypass Capacitors

Using an input bypass capacitor reduces peak current transients drawn from the input supply and reduces the switching noise generated by the regulator. The source impedance of the input supply determines the size of the capacitor that should be used.

FIGURE 3-1: BOOTSTRAPPED OPERATION

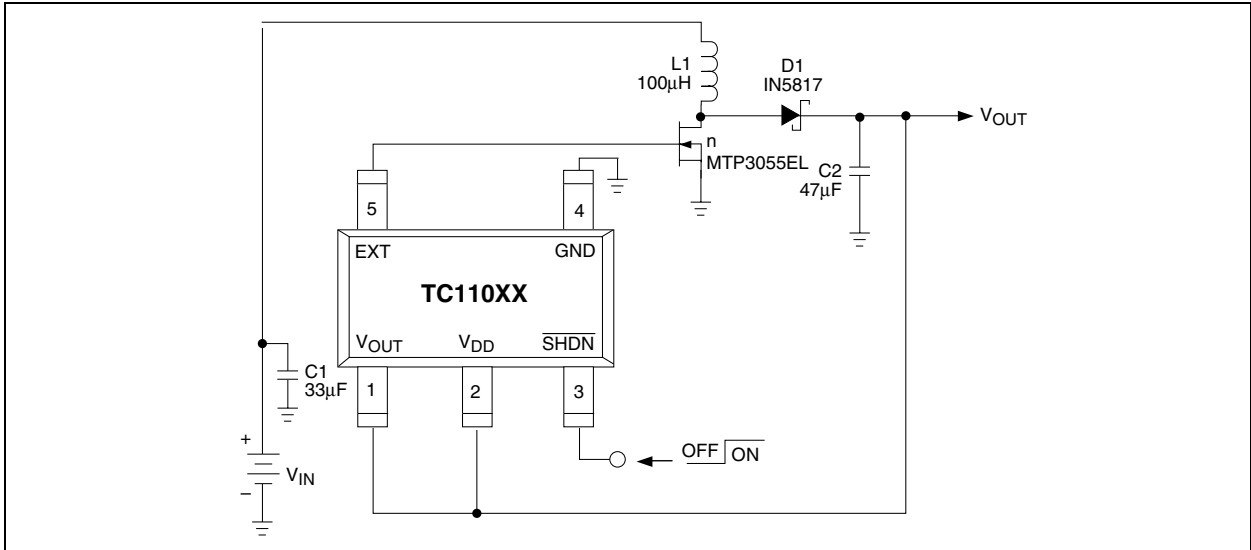

FIGURE 3-2: NON-BOOTSTRAPPED OPERATION

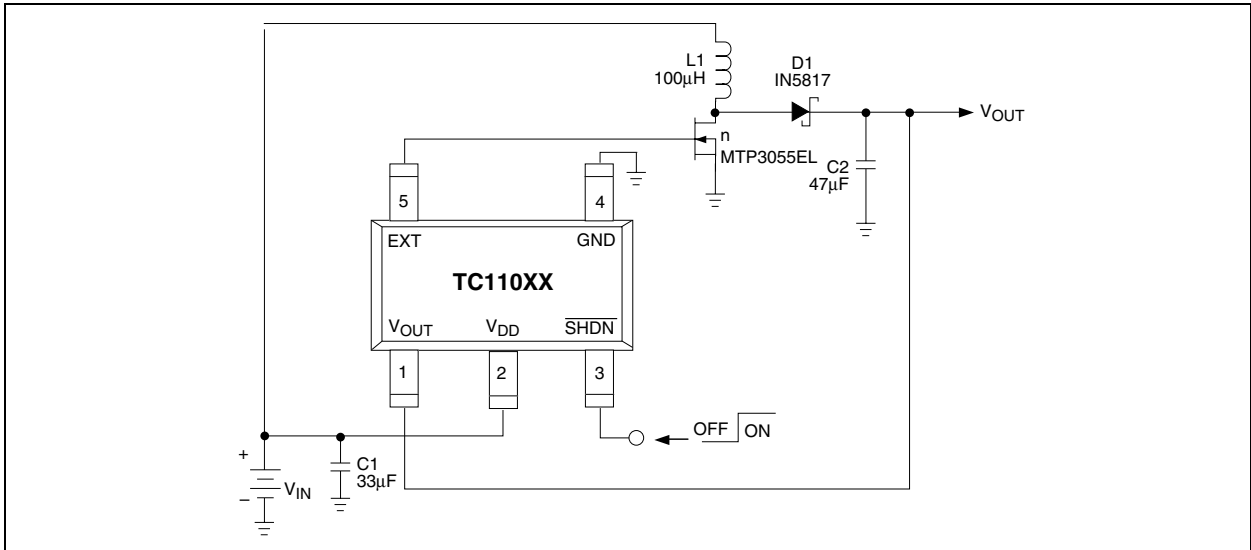
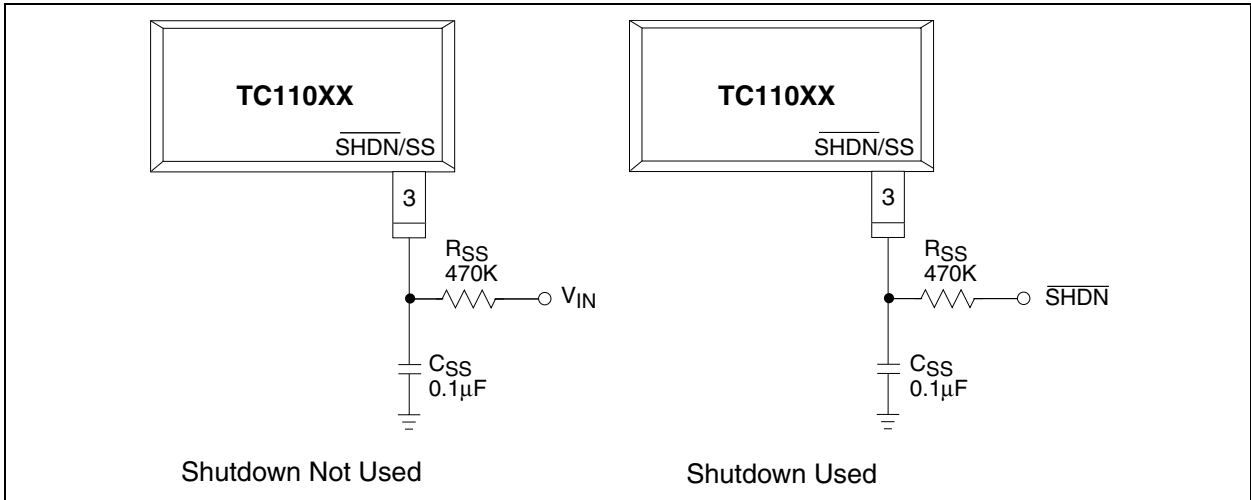

FIGURE 3-3: SOFT START/SHUTDOWN CIRCUIT



3.5 Output Capacitor

The effective series resistance of the output capacitor directly affects the amplitude of the output voltage ripple. (The product of the peak inductor current and the ESR determines output ripple amplitude.) Therefore, a capacitor with the lowest possible ESR should be selected. Smaller capacitors are acceptable for light loads or in applications where ripple is not a concern. The Sprague 595D series of tantalum capacitors are among the smallest of all low ESR surface mount capacitors available. Table 4-1 lists suggested components and suppliers.

3.6 Inductor Selection

Selecting the proper inductor value is a trade-off between physical size and power conversion requirements. Lower value inductors cost less, but result in higher ripple current and core losses. They are also more prone to saturate since the coil current ramps faster and could overshoot the desired peak value. This not only reduces efficiency, but could also cause the current rating of the external components to be exceeded. Larger inductor values reduce both ripple current and core losses, but are larger in physical size and tend to increase the start-up time slightly.

A 22 μ H inductor is recommended for the 300kHz versions and a 47 μ H inductor is recommended for the 100kHz versions. Inductors with a ferrite core (or equivalent) are also recommended. For highest efficiency, use inductors with a low DC resistance (less than 20 m Ω).

The inductor value directly affects the output ripple voltage. Equation 3-3 is derived as shown below, and can be used to calculate an inductor value, given the required output ripple voltage and output capacitor series resistance:

EQUATION 3-1:

$$V_{\text{RIPPLE}} \approx \text{ESR}(di)$$

where ESR is the equivalent series resistance of the output filter capacitor, and V_{RIPPLE} is in volts.

Expressing di in terms of switch ON resistance and time:

EQUATION 3-2:

$$V_{\text{RIPPLE}} \approx \frac{\text{ESR} [(V_{\text{IN}} - V_{\text{SW}})t_{\text{ON}}]}{L}$$

Solving for L:

EQUATION 3-3:

$$L \approx \frac{\text{ESR} [(V_{\text{IN}} - V_{\text{SW}})t_{\text{ON}}]}{V_{\text{RIPPLE}}}$$

Care must be taken to ensure the inductor can handle peak switching currents, which can be several times load currents. Exceeding rated peak current will result in core saturation and loss of inductance. The inductor should be selected to withstand currents greater than I_{PK} (Equation 3-10) without saturating.

Calculating the peak inductor current is straightforward. Inductor current consists of an AC (sawtooth) current centered on an average DC current (i.e., input current). Equation 3-6 calculates the average DC current. Note that minimum input voltage and maximum load current values should be used:

EQUATION 3-4:

$$\text{Input Power} = \frac{\text{Output Power}}{\text{Efficiency}}$$

Re-writing in terms of input and output currents and voltages:

EQUATION 3-5:

$$(V_{\text{INMIN}}) (I_{\text{INMAX}}) = \frac{(V_{\text{OUTMAX}}) (I_{\text{OUTMAX}})}{\text{Efficiency}}$$

Solving for input current:

EQUATION 3-6:

$$I_{\text{INMAX}} = \frac{(V_{\text{OUTMAX}})(I_{\text{OUTMAX}})}{(\text{Efficiency})(V_{\text{INMAX}})}$$

The sawtooth current is centered on the DC current level; swinging equally above and below the DC current calculated in Equation 3-6. The peak inductor current is the sum of the DC current plus half the AC current. Note that minimum input voltage should be used when calculating the AC inductor current (Equation 3-9).

EQUATION 3-7:

$$V = \frac{L(di)}{dt}$$

EQUATION 3-8:

$$di = \frac{V(dt)}{L}$$

EQUATION 3-9:

$$di = \frac{[(V_{\text{INMIN}} - V_{\text{SW}})t_{\text{ON}}]}{L}$$

where: $V_{\text{SW}} = V_{\text{CESAT}}$ of the switch (note if a CMOS switch is used substitute V_{CESAT} for $r_{\text{DS(ON)}} \times I_{\text{IN}}$)

Combining the DC current calculated in Equation 3-6, with half the peak AC current calculated in Equation 3-9, the peak inductor current is given by:

EQUATION 3-10:

$$I_{\text{PK}} = I_{\text{INMAX}} + 0.5(di)$$

3.7 Output Diode

For best results, use a Schottky diode such as the MA735, 1N5817, MBR0520L or equivalent. Connect the diode between the FB (or SENSE) input as close to the IC as possible. Do not use ordinary rectifier diodes since the higher threshold voltages reduce efficiency.

3.8 External Switching Transistor Selection

The EXT output is designed to directly drive an N-channel MOSFET or NPN bipolar transistor. N-channel MOSFETs afford the highest efficiency because they do not draw continuous gate drive current, but are typically more expensive than bipolar transistors. If using an N-channel MOSFET, the gate should be connected directly to the EXT output as shown in Figure 3-1 and Figure 3-1. EXT is a complementary output with a maximum ON resistances of 43Ω to V_{DD} when high and 27Ω to ground when low. Peak currents should be kept below 10mA.

When selecting an N-channel MOSFET, there are three important parameters to consider: total gate charge (Qg); ON resistance ($r_{DS(ON)}$) and reverse transfer capacitance (CRSS). Qg is a measure of the total gate capacitance that will ultimately load the EXT output. Too high a Qg can reduce the slew rate of the EXT output sufficiently to grossly lower operating efficiency. Transistors with typical Qg data sheet values of 50nC or less can be used. For example, the Si9410DY has a Qg (typ) of 17nC @ $V_{GS} = 5V$. This equates to a gate current of:

$$I_{GATEMAX} = f_{MAX} \times Qg = 115kHz \times 17nC = 2mA$$

The two most significant losses in the N-channel MOSFET are switching loss and I^2R loss. To minimize these, a transistor with low $r_{DS(ON)}$ and low CRSS should be used.

Bipolar NPN transistors can be used, but care must be taken when determining base current drive. Too little current will not fully turn the transistor on, and result in unstable regulator operation and low efficiency. Too high a base drive causes excessive power dissipation in the transistor and increase switching time due to over-saturation. For peak efficiency, make R_B as large as possible, but still guaranteeing the switching transistor is completely saturated when the minimum value of h_{FE} is used.

3.9 Board Layout Guidelines

As with all inductive switching regulators, the TC110 generates fast switching waveforms which radiate noise. Interconnecting lead lengths should be minimized to keep stray capacitance, trace resistance and radiated noise as low as possible. In addition, the GND pin, input bypass capacitor and output filter capacitor ground leads should be connected to a single point. The input capacitor should be placed as close to power and ground pins of the TC110 as possible.

TC110

4.0 APPLICATIONS

4.1 Circuit Examples

Figure 4-1 shows a TC110 operating as a 100kHz bootstrapped regulator with soft start. This circuit uses an NPN switching transistor (Zetex FZT690B) that has an h_{FE} of 400 and V_{CESAT} of 100 mV at $I_C = 1A$. Other high beta transistors can be used, but the values of R_B and C_B may need adjustment if h_{FE} is significantly different from that of the FZT690B.

Figure 4-2 and Figure 4-3 both utilize an N-channel switching transistor (Silconix Si9410DY). This transistor is a member of the Littlefoot™ family of small outline MOSFETs. The circuit of Figure 4-2 operates in bootstrapped mode, while the circuit of Figure 4-3 operates in non-bootstrapped mode.

TABLE 4-1: SUGGESTED COMPONENTS AND SUPPLIERS

Type	Inductors	Capacitors	Diodes	Transistors
Surface Mount	Sumida CD54 Series (300kHz) CD75 (100kHz) Coiltronics CTX Series	Matsuo 267 Series Sprague 595D Series Nichicon F93 Series	Nihon EC10 Series Matsushita MA735 Series	N-channel Silconix Si9410DY ON Semiconductor MTP3055EL MTD20N03
Through-Hole	Sumida RCH855 Series RCH110 Series Renco RL1284-12	Sanyo OS-CON Series Nichicon PL Series	ON Semiconductor 1N5817 - 1N5822	NPN Zetex ZTX694B

FIGURE 4-1: 100kHz BOOTSTRAPPED REGULATOR WITH SOFT START USING A BIPOLAR TRANSISTOR

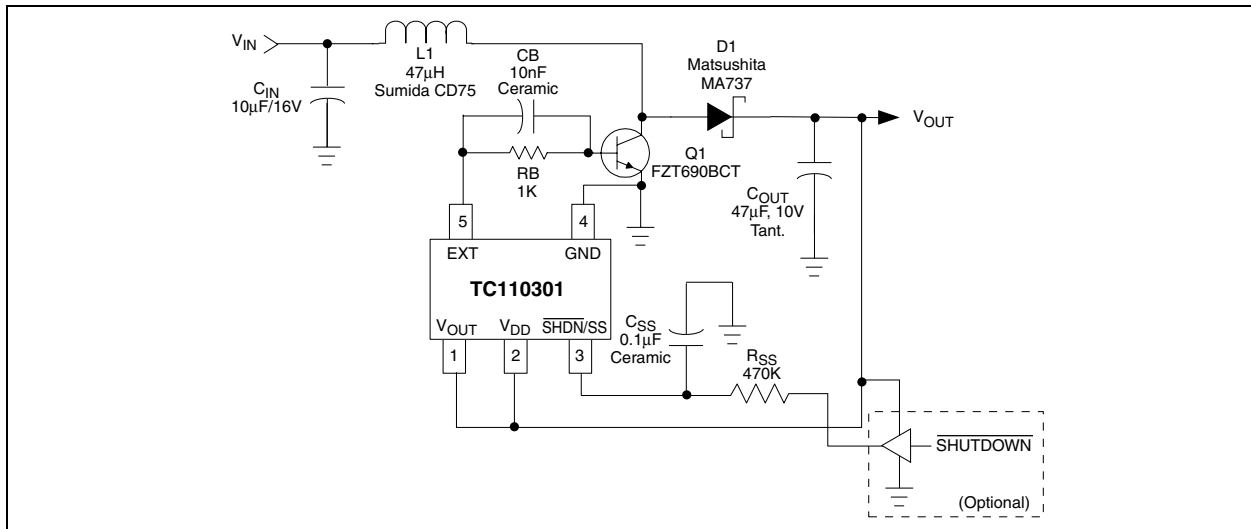

FIGURE 4-2: 300kHz BOOTSTRAPPED, N-CHANNEL TRANSISTOR

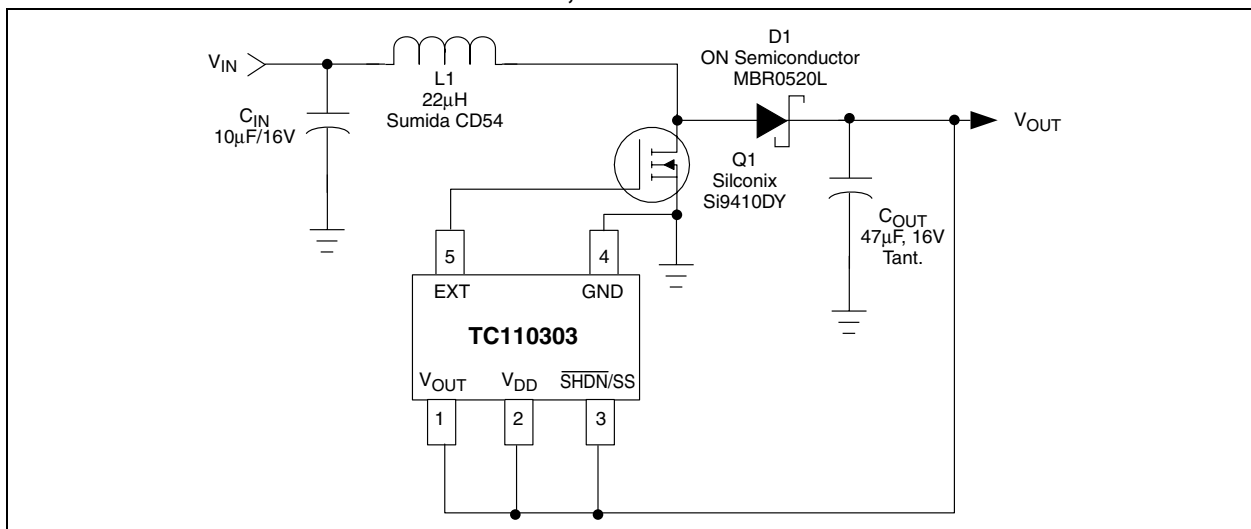
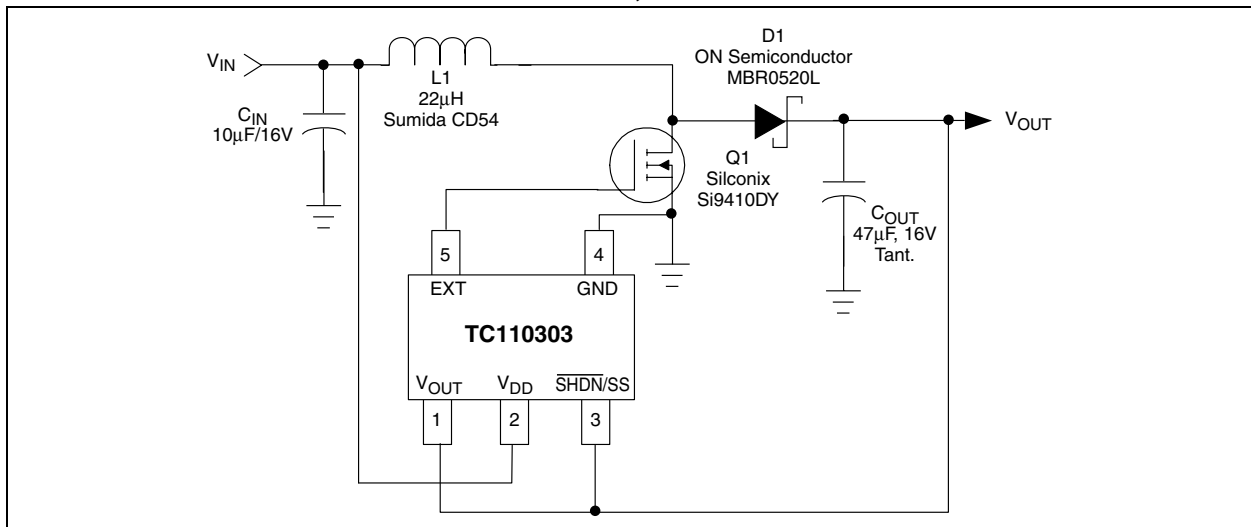

FIGURE 4-3: 300kHz NON-BOOTSTRAPPED, N-CHANNEL TRANSISTOR



TC110

5.0 TYPICAL CHARACTERISTICS

(Unless Otherwise Specified, All Parts Are Measured At Temperature = 25°C)

Note: The graphs and tables provided following this note are a statistical summary based on a limited number of samples and are provided for informational purposes only. The performance characteristics listed herein are not tested or guaranteed. In some graphs or tables, the data presented may be outside the specified operating range (e.g., outside specified power supply range) and therefore outside the warranted range.

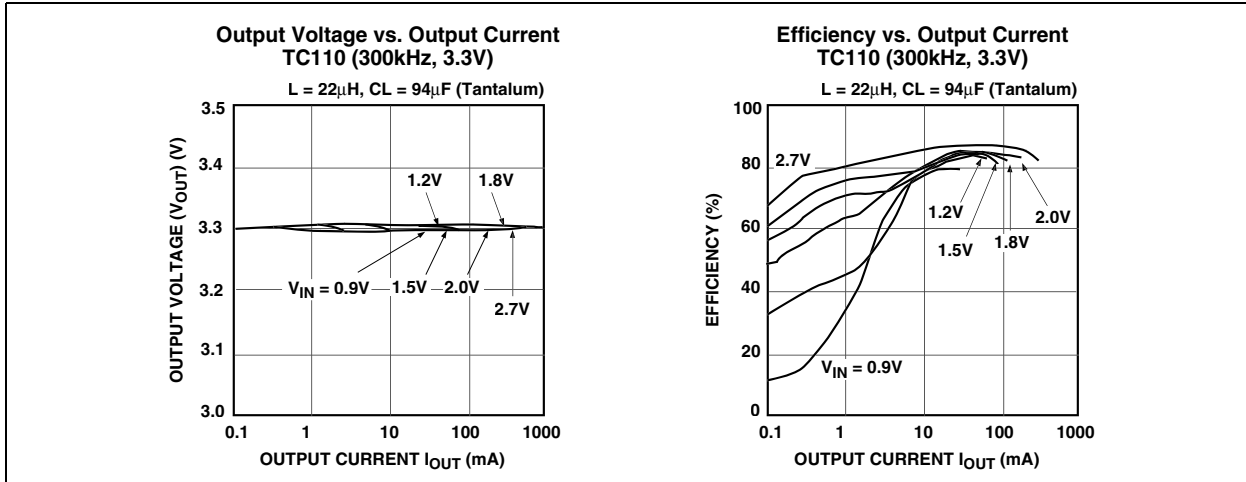

6.0 PACKAGING INFORMATION

6.1 Package Marking Information

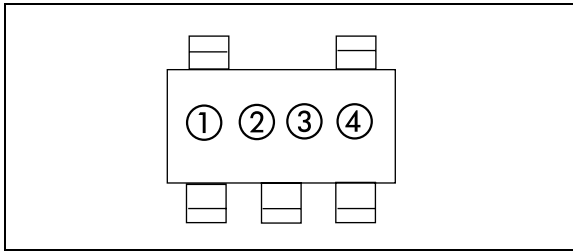

① represents product classification; TC110 = M

② represents first integer of voltage and frequency

Symbol (100kHz)	Symbol (300kHz)	Voltage
B	1	1.
C	2	2.
D	3	3.
E	4	4.
F	5	5.
H	6	6.

③ represents first decimal of voltage and frequency

Symbol (100kHz)	Symbol (300kHz)	Voltage
0	A	.0
1	B	.1
2	C	.2
3	D	.3
4	E	.4
5	F	.5
6	H	.6
7	K	.7
8	L	.8
9	M	.9

④ represents production lot ID code

6.2 Taping Form

Component Taping Orientation for 5-Pin SOT-23A (EIAJ SC-74A) Devices

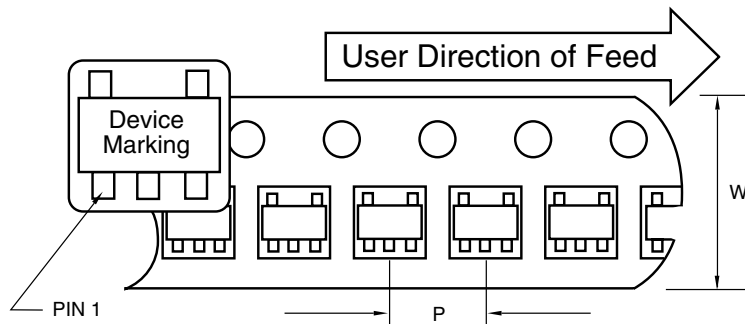

Standard Reel Component Orientation
 TR Suffix Device
 (Mark Right Side Up)

Carrier Tape, Number of Components Per Reel and Reel Size

Package	Carrier Width (W)	Pitch (P)	Part Per Full Reel	Reel Size
5-Pin SOT-23A	8 mm	4 mm	3000	7 in

6.3 Package Dimensions

SOT-23A-5

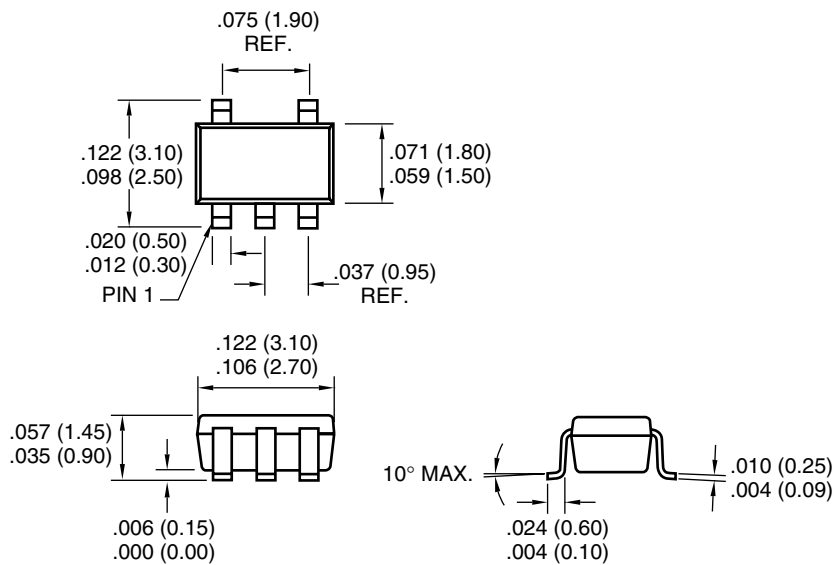

Dimensions: inches (mm)

Sales and Support

Data Sheets

Products supported by a preliminary Data Sheet may have an errata sheet describing minor operational differences and recommended workarounds. To determine if an errata sheet exists for a particular device, please contact one of the following:

1. Your local Microchip sales office
2. The Microchip Corporate Literature Center U.S. FAX: (480) 792-7277
3. The Microchip Worldwide Site (www.microchip.com)

Please specify which device, revision of silicon and Data Sheet (include Literature #) you are using.

New Customer Notification System

Register on our web site (www.microchip.com/cn) to receive the most current information on our products.

TC110

NOTES:

Information contained in this publication regarding device applications and the like is intended through suggestion only and may be superseded by updates. It is your responsibility to ensure that your application meets with your specifications. No representation or warranty is given and no liability is assumed by Microchip Technology Incorporated with respect to the accuracy or use of such information, or infringement of patents or other intellectual property rights arising from such use or otherwise. Use of Microchip's products as critical components in life support systems is not authorized except with express written approval by Microchip. No licenses are conveyed, implicitly or otherwise, under any intellectual property rights.

Trademarks

The Microchip name and logo, the Microchip logo, FilterLab, KEELOQ, microID, MPLAB, PIC, PICmicro, PICMASTER, PICSTART, PRO MATE, SEEVAL and The Embedded Control Solutions Company are registered trademarks of Microchip Technology Incorporated in the U.S.A. and other countries.

dsPIC, ECONOMONITOR, FanSense, FlexROM, fuzzyLAB, In-Circuit Serial Programming, ICSP, ICEPIC, microPort, Migratable Memory, MPASM, MPLIB, MPLINK, MPSIM, MXDEV, MXLAB, PICC, PICDEM, PICDEM.net, rPIC, Select Mode and Total Endurance are trademarks of Microchip Technology Incorporated in the U.S.A.

Serialized Quick Turn Programming (SQTP) is a service mark of Microchip Technology Incorporated in the U.S.A.

All other trademarks mentioned herein are property of their respective companies.

© 2002, Microchip Technology Incorporated, Printed in the U.S.A., All Rights Reserved.

 Printed on recycled paper.



Microchip received QS-9000 quality system certification for its worldwide headquarters, design and wafer fabrication facilities in Chandler and Tempe, Arizona in July 1999 and Mountain View, California in March 2002. The Company's quality system processes and procedures are QS-9000 compliant for its PICmicro® 8-bit MCUs, KEELOQ® code hopping devices, Serial EEPROMs, microperipherals, non-volatile memory and analog products. In addition, Microchip's quality system for the design and manufacture of development systems is ISO 9001 certified.



MICROCHIP

WORLDWIDE SALES AND SERVICE

AMERICAS

Corporate Office

2355 West Chandler Blvd.
Chandler, AZ 85224-6199
Tel: 480-792-7200 Fax: 480-792-7277
Technical Support: 480-792-7627
Web Address: <http://www.microchip.com>

Rocky Mountain

2355 West Chandler Blvd.
Chandler, AZ 85224-6199
Tel: 480-792-7966 Fax: 480-792-7456

Atlanta

500 Sugar Mill Road, Suite 200B
Atlanta, GA 30350
Tel: 770-640-0034 Fax: 770-640-0307

Boston

2 Lan Drive, Suite 120
Westford, MA 01886
Tel: 978-692-3848 Fax: 978-692-3821

Chicago

333 Pierce Road, Suite 180
Itasca, IL 60143
Tel: 630-285-0071 Fax: 630-285-0075

Dallas

4570 Westgrove Drive, Suite 160
Addison, TX 75001
Tel: 972-818-7423 Fax: 972-818-2924

Detroit

Tri-Atria Office Building
32255 Northwestern Highway, Suite 190
Farmington Hills, MI 48334
Tel: 248-538-2250 Fax: 248-538-2260

Kokomo

2767 S. Albright Road
Kokomo, Indiana 46902
Tel: 765-864-8360 Fax: 765-864-8387

Los Angeles

18201 Von Karman, Suite 1090
Irvine, CA 92612
Tel: 949-263-1888 Fax: 949-263-1338

New York

150 Motor Parkway, Suite 202
Hauppauge, NY 11788
Tel: 631-273-5305 Fax: 631-273-5335

San Jose

Microchip Technology Inc.
2107 North First Street, Suite 590
San Jose, CA 95131
Tel: 408-436-7950 Fax: 408-436-7955

Toronto

6285 Northam Drive, Suite 108
Mississauga, Ontario L4V 1X5, Canada
Tel: 905-673-0699 Fax: 905-673-6509

ASIA/PACIFIC

Australia

Microchip Technology Australia Pty Ltd
Suite 22, 41 Rawson Street
Epping 2121, NSW
Australia
Tel: 61-2-9868-6733 Fax: 61-2-9868-6755

China - Beijing

Microchip Technology Consulting (Shanghai)
Co., Ltd., Beijing Liaison Office
Unit 915
Bei Hai Wan Tai Bldg.
No. 6 Chaoyangmen Beidajie
Beijing, 100027, No. China
Tel: 86-10-85282100 Fax: 86-10-85282104

China - Chengdu

Microchip Technology Consulting (Shanghai)
Co., Ltd., Chengdu Liaison Office
Rm. 2401, 24th Floor,
Ming Xing Financial Tower
No. 88 TIDU Street
Chengdu 610016, China
Tel: 86-28-86766200 Fax: 86-28-86766599

China - Fuzhou

Microchip Technology Consulting (Shanghai)
Co., Ltd., Fuzhou Liaison Office
Unit 28F, World Trade Plaza
No. 71 Wusi Road
Fuzhou 350001, China
Tel: 86-591-7503506 Fax: 86-591-7503521

China - Shanghai

Microchip Technology Consulting (Shanghai)
Co., Ltd.
Room 701, Bldg. B
Far East International Plaza
No. 317 Xian Xia Road
Shanghai, 200051
Tel: 86-21-6275-5700 Fax: 86-21-6275-5060

China - Shenzhen

Microchip Technology Consulting (Shanghai)
Co., Ltd., Shenzhen Liaison Office
Rm. 1315, 13/F, Shenzhen Kerry Centre,
Renminnan Lu
Shenzhen 518001, China
Tel: 86-755-2350361 Fax: 86-755-2366086

China - Hong Kong SAR

Microchip Technology Hongkong Ltd.
Unit 901-6, Tower 2, Metroplaza
223 Hing Fong Road
Kwai Fong, N.T., Hong Kong
Tel: 852-2401-1200 Fax: 852-2401-3431

India

Microchip Technology Inc.
India Liaison Office
Divyasree Chambers
1 Floor, Wing A (A3/A4)
No. 11, O'Shaugnessey Road
Bangalore, 560 025, India
Tel: 91-80-2290061 Fax: 91-80-2290062

Japan

Microchip Technology Japan K.K.
Benex S-1 6F
3-18-20, Shinyokohama
Kohoku-Ku, Yokohama-shi
Kanagawa, 222-0033, Japan
Tel: 81-45-471-6166 Fax: 81-45-471-6122

Korea

Microchip Technology Korea
168-1, Youngbo Bldg. 3 Floor
Samsung-Dong, Kangnam-Ku
Seoul, Korea 135-882
Tel: 82-2-554-7200 Fax: 82-2-558-5934

Singapore

Microchip Technology Singapore Pte Ltd.
200 Middle Road
#07-02 Prime Centre
Singapore, 188980
Tel: 65-6334-8870 Fax: 65-6334-8850

Taiwan

Microchip Technology Taiwan
11F-3, No. 207
Tung Hua North Road
Taipei, 105, Taiwan
Tel: 886-2-2717-7175 Fax: 886-2-2545-0139

EUROPE

Denmark

Microchip Technology Nordic ApS
Regus Business Centre
Lautrup høj 1-3
Ballerup DK-2750 Denmark
Tel: 45 4420 9895 Fax: 45 4420 9910

France

Microchip Technology SARL
Parc d'Activite du Moulin de Massy
43 Rue du Saule Trapu
Batiment A - 1er Etage
91300 Massy, France
Tel: 33-1-69-53-63-20 Fax: 33-1-69-30-90-79

Germany

Microchip Technology GmbH
Gustav-Heinemann Ring 125
D-81739 Munich, Germany
Tel: 49-89-627-144 0 Fax: 49-89-627-144-44

Italy

Microchip Technology SRL
Centro Direzionale Colleoni
Palazzo Taurus 1 V. Le Colleoni 1
20041 Agrate Brianza
Milan, Italy
Tel: 39-039-65791-1 Fax: 39-039-6899883

United Kingdom

Microchip Ltd.
505 Eskdale Road
Winnersh Triangle
Wokingham
Berkshire, England RG41 5TU
Tel: 44 118 921 5869 Fax: 44-118 921-5820

05/01/02