

TA8083F

DUAL DC MOTOR DRIVER

The TA8083F contains two motor driver circuits with a current capacity of 0.5A for directly driving bidirectional DC motors. Inputs DI1 A/B and DI2 A/B are combined to select one of forward, reverse Stop, and brake modes. Since the inputs are TTL-Compatible, this IC can be controlled directly from a CPU or other control system. In addition, the IC also has a low stand by current function, a self-diagnostic function, and various protective functions.

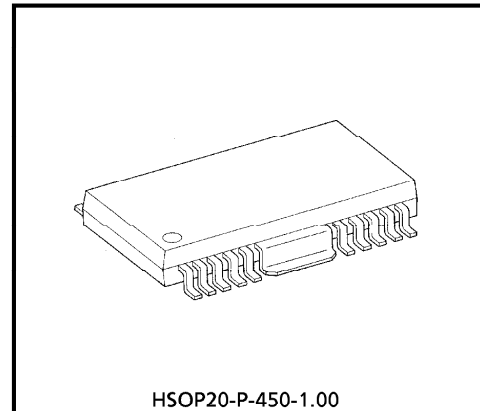

Weight : 0.79g (Typ.)

FEATURES

- 0.5A bidirectional DC motor driver.
- Two circuits contained (power supply, self-diagnostic, and protective functions provide for each channel)
- Low standby current : 0.1mA (Max.)
- Self-diagnostic output : short-circuit mode (1A Typ.)
- Protective functions : Thermal-Shutdown, Short-Circuit Protection, and Over-voltage Shutdown
- Built-in counter electromotive force absorption diodes.
- HSOP 20pin power flat package.

BLOCK DIAGRAM AND PIN LAYOUT

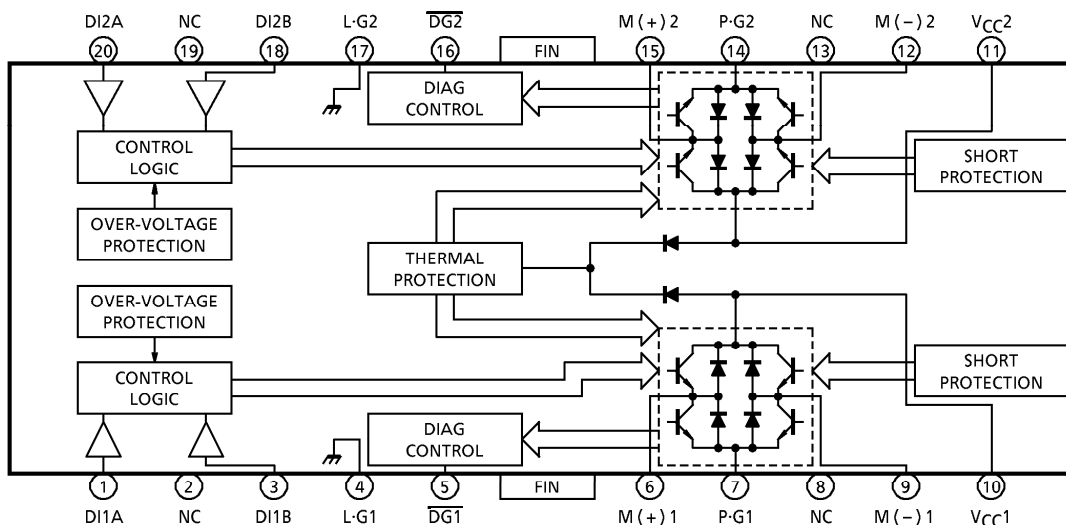

961001EBA2

- TOSHIBA is continually working to improve the quality and the reliability of its products. Nevertheless, semiconductor devices in general can malfunction or fail due to their inherent electrical sensitivity and vulnerability to physical stress. It is the responsibility of the buyer, when utilizing TOSHIBA products, to observe standards of safety, and to avoid situations in which a malfunction or failure of a TOSHIBA product could cause loss of human life, bodily injury or damage to property. In developing your designs, please ensure that TOSHIBA products are used within specified operating ranges as set forth in the most recent products specifications. Also, please keep in mind the precautions and conditions set forth in the TOSHIBA Semiconductor Reliability Handbook.
- The products described in this document are subject to foreign exchange and foreign trade control laws.
- The information contained herein is presented only as a guide for the applications of our products. No responsibility is assumed by TOSHIBA CORPORATION for any infringements of intellectual property or other rights of the third parties which may result from its use. No license is granted by implication or otherwise under any intellectual property or other rights of TOSHIBA CORPORATION or others.
- The information contained herein is subject to change without notice.

PIN DESCRIPTION

PIN No.		SYMBOL		DESCRIPTION
CH1	CH2	CH1	CH2	
1	20	DI1A	DI2A	Input pin. The signal from this pin controls the output state. (see TRUTH TABLE 1.)
3	18	DI1B	DI2B	
4	17	L·G1	L·G2	Ground terminal for Logic portion.
5	16	$\overline{DG1}$	$\overline{DG2}$	Self-diagnosis output pins (See Table 2, Truth Table & Timing Chart.) NPN transistor open-collector output. When output becomes overcurrent, set to on; duty 97% on (low). At normal operation or at the time of STOP, set to open (high).
6	15	M(+) ₁	M(+) ₂	Connects to the DC motor. Both the sink and the source have a current capacity of 0.5A. Features overcurrent detection function to protect IC from instantaneous destruction at load short, ground fault, or direct connection to high power. (See section on Multiple Protections below.) Features diodes for absorbing counter electromotive force built into both V _{CC} and Gnd sides.
7	14	P·G1	P·G2	Ground terminal for output portion.
9	12	M(-) ₁	M(-) ₂	Connects to the motor for CH1 (CH2) together with pin 6 (15) and has the same function as pin 6 (15). This pin is controlled by the inputs from pins 1 (20) and 3 (18).
10	11	V _{CC1}	V _{CC2}	Power supply pin. This pin has a function to turn off the output when the applied voltage exceeds 30V, thus protecting the IC and the motor load.
2, 8, 13, 19		NC		Not connected.

TRUTH TABLE 1 INPUT / OUTPUT

INPUT		OUTPUT		OPERATION MODE
DI1 / 2A	DI1 / 2B	M1 (+) / 2 (+)	M1 (-) / 2 (-)	
H	H	L	L	Brake
L	H	L	H	Reverse (CCW)
H	L	H	L	Forward (CW)
L	L	OFF (High impedance)		Stop (standby)

TRUTH TABLE 2 SELF-DIAGNOSIS

INPUT		OUTPUT		\overline{DIAG}
DI1 / 2A	DI1 / 2B	MODE	LOAD	
H	H	Brake	Normal	H
			Short	L*
L / H	H / L	CCW / CW	Normal	H
			Short	L*
L	L	Stop	—	H

* See TIMING CHART

SELF-DIAGNOSIS TIMIGN CHART

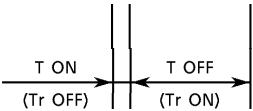
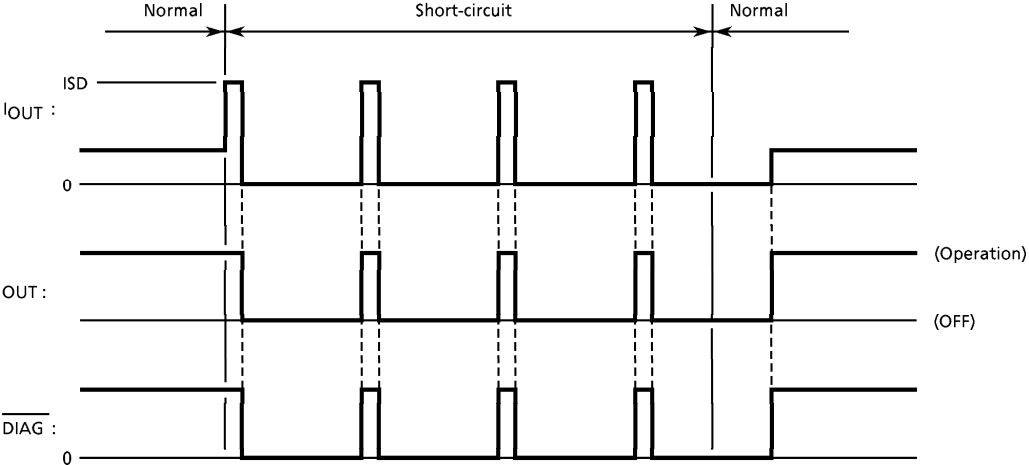

$$\frac{T\ ON}{T\ ON + T\ OFF} = 3\%$$

DESCRIPTION OF MULTI-PROTECTIVE OPERATION

The TA8083F has functions for protection from over-voltage (V_{SD}), over-current (I_{SD}), and overheat (T_{SD}). These functions protect the IC (and the motor load in some cases) from deterioration or destruction due to power-related overstress.

The three functions work independently.

Each function is explained below.

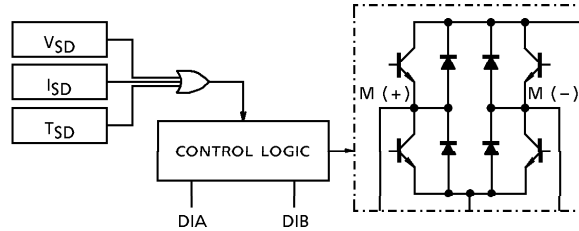

1. Over-voltage protection (V_{SD})

- Basic operation

When the voltage supplied to the V_{CC} pin is up to the V_{SD} detection voltage, the output is controlled by the input signals. However, when the V_{CC} voltage exceeds the detection voltage, the output enters high-impedance state regardless of the input signals.

- Detailed explanation

The V_{SD} voltage is detected by comparing the Zener voltage with the voltage obtained by dividing V_{CC} with a resistor. When the center voltage of the resistor is higher than the Zener voltage, a transistor-off instruction is issued to the control logic. When it is lower than the Zener voltage, the logic is controlled by the input signals from DIA and DIB.

2. Overheat protection (T_{SD})

- Basic operation

When the junction (chip) temperature is up to the T_{SD} detection temperature, the output is controlled by the input signals. When it exceeds the T_{SD} detection temperature, the output enters high-impedance state regardless of the input signals.

- Detailed explanation

The temperature is detected by monitoring V_F of a diode on the chip. When the diode V_F is lower than the internal reference voltage, an output transistor-off instruction is issued to the control logic. When it is higher than the internal reference voltage, the logic is controlled by the input signals from DIA and DIB.

3. Over-current protection (I_{SD})

- Basic operation

When the output current ($M(+)$ or $M(-)$, Isink or Isource) is up to the I_{SD} detection current, the output is controlled by the input signals. When it exceeds the detection current, the output assumes a switching waveform as shown in Fig.1.

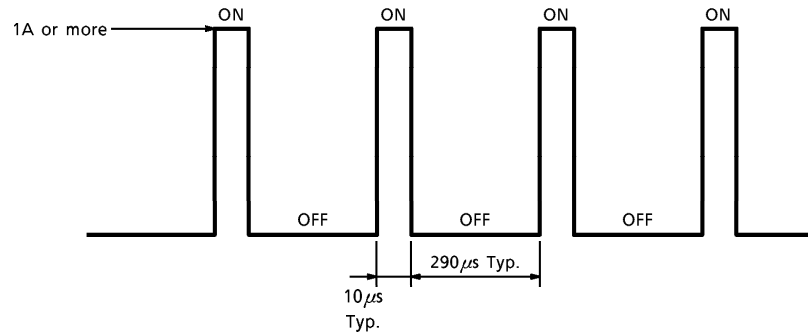

Fig.1 Basic Operation

- Detailed explanation

The output current is detected by monitoring the sense resistance. One detection circuit connects to one of the circuits (CH1 or CH2) and leads to the short-circuit protection circuit. When a current exceeding the I_{SD} detection current flows through one of the four output transistors, the short-circuit protection circuit is activated. This circuit contains a timer. When over-current condition continues for $10\mu s$ (typically), the protection circuit places the output in high-impedance mode and, $290\mu s$ (typically) later, returns the IC to ON mode. The switching-waveform output is repeated until over-current condition is no longer present.

- Caution for application

The overcurrent protection is used to protect the IC from instantaneous destruction due to short circuits. If overcurrent continues, configure a system which changes the IC to standby mode using the self diagnosis signal.

Note that the time required for switching the IC from output short (overcurrent detection) to standby must be 1s or less.

MAXIMUM RATINGS (Ta = 25°C)

CHARACTERISTIC	SYMBOL	RATING	UNIT
Power Supply Voltage	V _{CC}	30	V
	V _{CC}	60 (1s)	
Input Voltage	V _{IN}	-0.3V~V _{CC} +0.3	V
Output Current	I _O ·AVE	0.5	A
Power Dissipation	P _D	2	W (*)
Operating Temperature	T _{opr}	-40~110	°C
Storage Temperature	T _{stg}	-55~150	°C
Lead Temperature-Time	T _{sol}	260 (10s)	°C

(*) On Board Condition. (50×50×1.6mm 50% Cu)

ELECTRICAL CHARACTERISTICS (V_{CC} = 8~16V, T_c = -40~110°C)

CHARACTERISTIC	SYMBOL	PIN	TEST CIRCUIT	TEST CONDITION	MIN.	TYP.	MAX.	UNIT
Power Supply Current	I _{CC1}	V _{CC1} /V _{CC2}	—	CH1/CH2 : Stop	—	—	0.1	mA
	I _{CC2}		—	CH1 or CH2 : CW/CCW	—	20	30	
	I _{CC3}		—	CH1/CH2 : CW/CCW	—	40	60	
	I _{CC4}		—	CH1/CH2 : Brake	—	10	16	
Input Voltage	V _{IL}	DI1A/B DI2A/B	—	—	—	—	0.8	V
	V _{IH}		—	—	2.0	—	—	
Input Current	I _{IL}	DI1A/B DI2A/B	—	V _{IN} = 0.4V	—	10	20	μA
	I _{IH}		—	V _{IN} = 5V	—	300	600	
Output Saturation Voltage	V _{sat} (total)	M(+)/(-)1/ M(+)/(-)2	—	I _{OUT} = 0.4A, T _c = 25°C	—	1.8	2.5	V
			—	I _{OUT} = 0.4A, T _c = 110°C	—	1.7	2.4	
Output Leakage Current	I _{LEAK·U}	M(+)/(-)1/ M(+)/(-)2	—	V _{OUT} = 0V	-10	—	—	μA
	I _{LEAK·L}		—	V _{OUT} = V _{CC}	—	—	10	
Diode Forward Voltage	V _{F U}	—	—	I _F = 0.4A	—	1.5	—	V
	V _{F L}		—		—	1.5	—	
Output Voltage	V _{OL}	DG1/DG2	—	I _{OL} = 3mA	—	—	0.5	V
Output Leakage Current	I _{LEAK}		—	V _{OUT} = V _{CC}	—	—	10	μA
Over-current Detection	I _{SD}	—	—	—	—	1.0	—	A
Shutdown Temperature	T _{SD}	—	—	ON→OFF	—	150	—	°C
Over-voltage Detection	V _{SD}	—	—	—	—	30	—	V
Transfer Delay Time	T _{PLH}	—	—	—	—	1	10	μs
	T _{PHL}	—	—	—	—	1	10	

I/O EQUIVALENT CIRCUIT

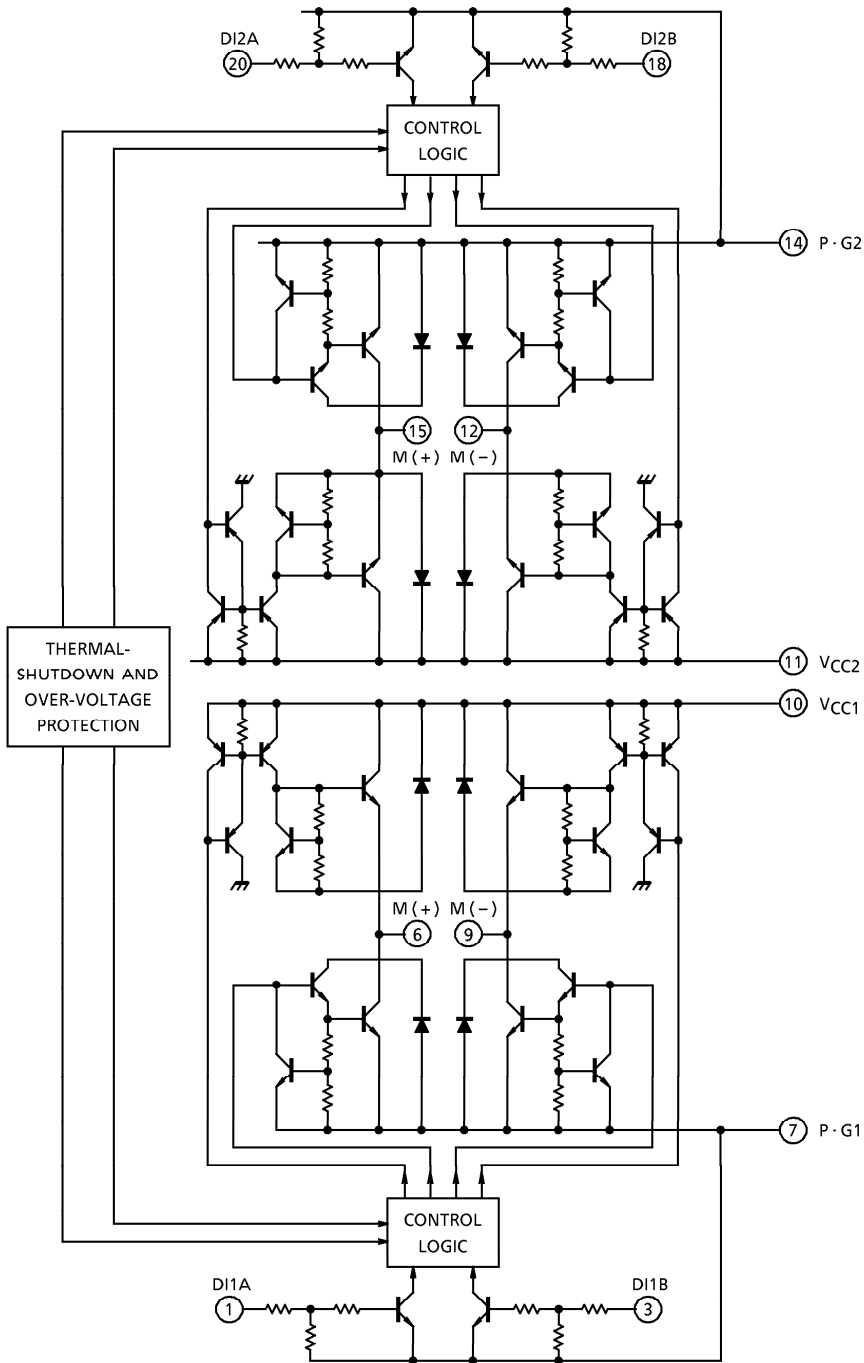

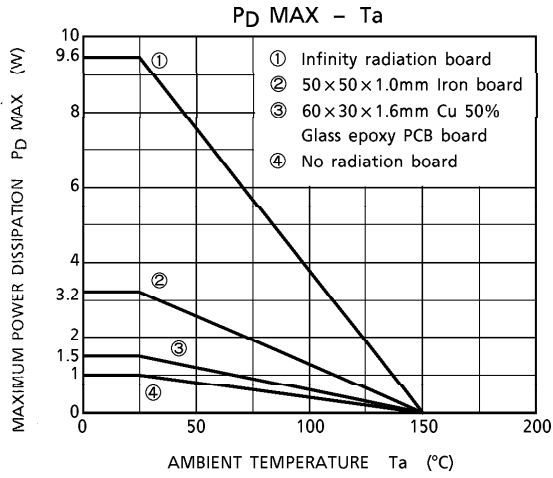

APPLICATION CIRCUIT

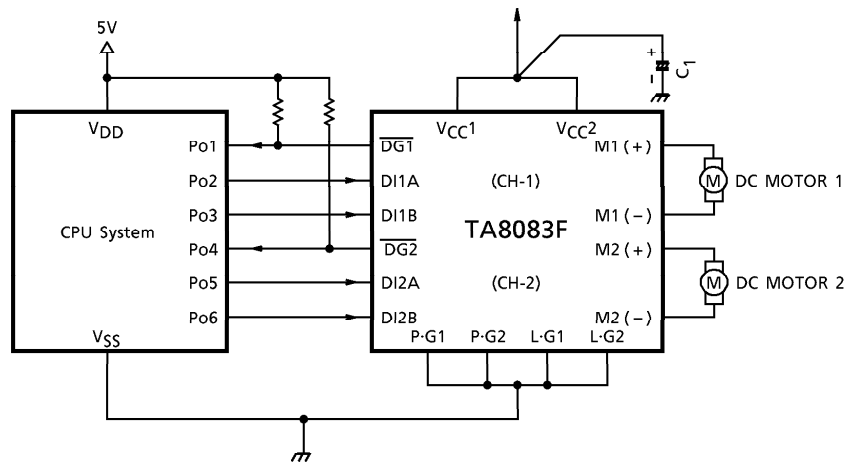

Cautions for wirings

C₁ is for absorbing disturbance, noise, etc.
 Connect it as close to the IC as possible.

OUTLINE DRAWING
HSOP20-P-450-1.00

Unit : mm

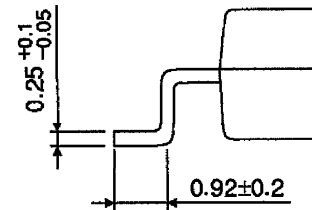
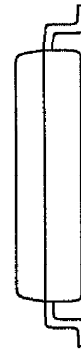
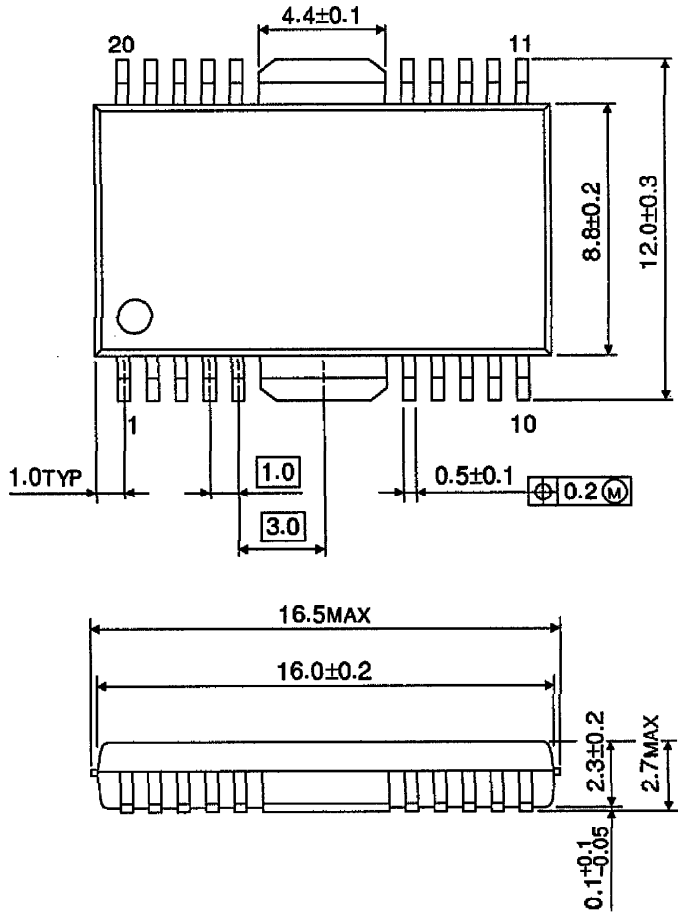

Weight : 0.79g (Typ.)