

TOSHIBA BIPOLAR LINEAR INTEGRATED CIRCUIT SILICON MONOLITHIC

TA2057N, TA2057F

AM / FM IF + FM ST DET (for Digital Tuning System)

TA2057N and TA2057F are the AM / FM IF + FM ST DET system ICs, which are designed for DTS Radios. These are included many functions and these can be used for Digital Tuning System with IF Counter.

FEATURES

- Suitable for combination with Digital Tuning System which has IF Counter.
- One terminal type AM / FM IF Count Output (Auto Stop Signal) for IF Counter of Digital Tuning System.
- Built-in Mute Circuit for IF Count Output.
- Adjustable for IF Count Output Sensitivity by External Resistance of pin② (AM), and pin③ (FM).
- For adopting Ceramic Discriminator and Ceramic Resonator, it is not necessary to adjust the FM Quad Detector Circuit and FM ST DET VCO Circuit.
- Built-in AM Local Oscillator Buffer Output Circuit.
- Built-in AM IF Buffer Output Circuit for AM Stereo.
- Operating Supply Voltage Range (Ta = 25°C)
TA2057N : $V_{CC} = 3.5 \sim 14V$
TA2057F : $V_{CC} = 3.5 \sim 9V$

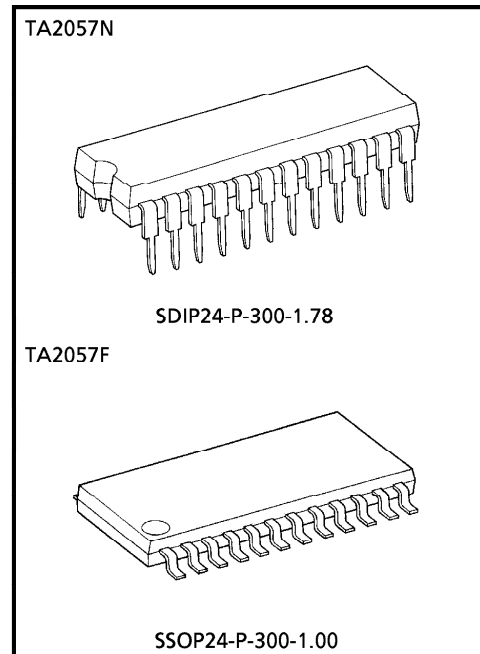

Weight
SDIP24-P-300-1.78 : 1.2g (Typ.)
SSOP24-P-300-1.00 : 0.31g (Typ.)

※ Handle with care to prevent devices from deteriorations by static electricity.

961001EBA2

● TOSHIBA is continually working to improve the quality and the reliability of its products. Nevertheless, semiconductor devices in general can malfunction or fail due to their inherent electrical sensitivity and vulnerability to physical stress. It is the responsibility of the buyer, when utilizing TOSHIBA products, to observe standards of safety, and to avoid situations in which a malfunction or failure of a TOSHIBA product could cause loss of human life, bodily injury or damage to property. In developing your designs, please ensure that TOSHIBA products are used within specified operating ranges as set forth in the most recent products specifications. Also, please keep in mind the precautions and conditions set forth in the TOSHIBA Semiconductor Reliability Handbook.

BLOCK DIAGRAM

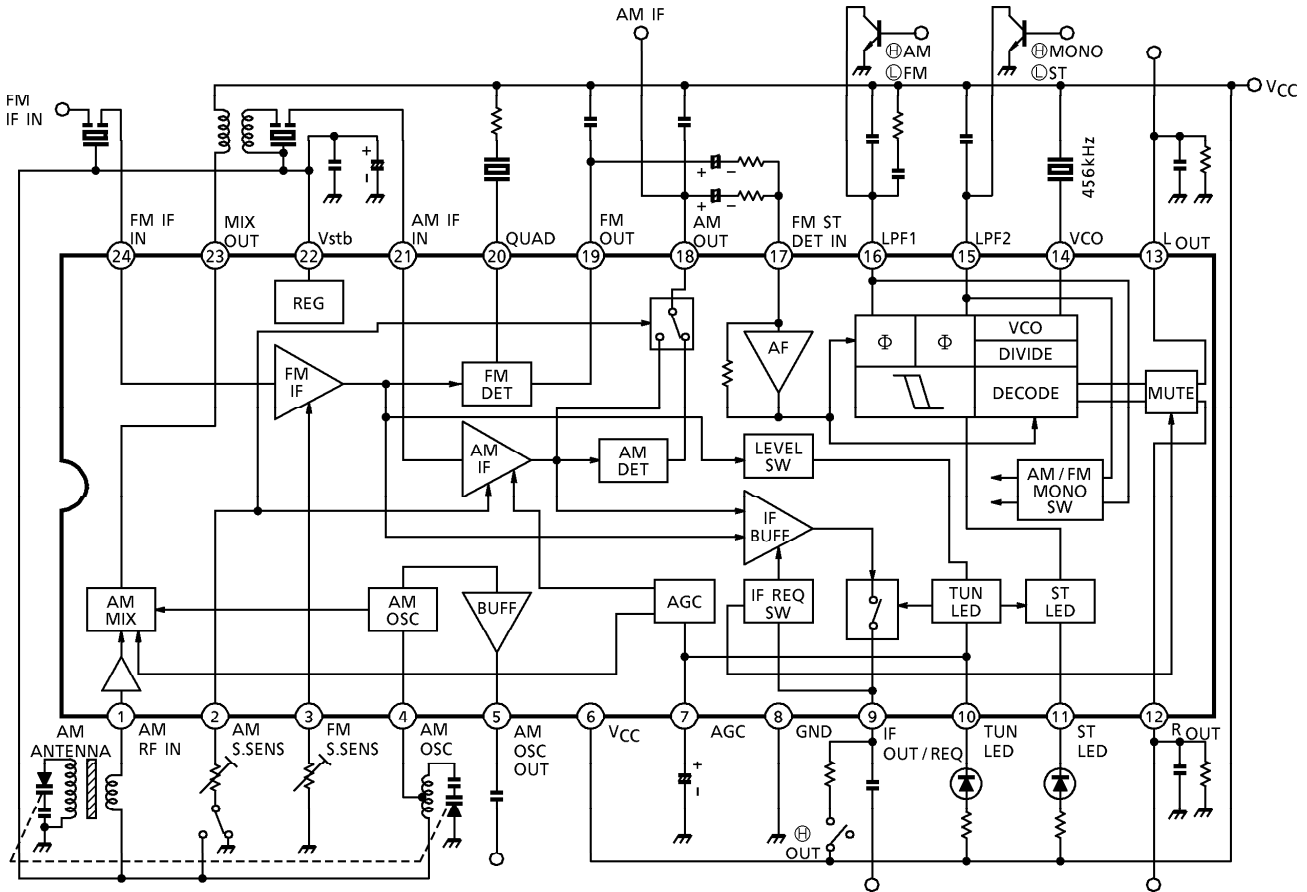

961001EBA2'

- The products described in this document are subject to foreign exchange and foreign trade control laws.
- The information contained herein is presented only as a guide for the applications of our products. No responsibility is assumed by TOSHIBA CORPORATION for any infringements of intellectual property or other rights of the third parties which may result from its use. No license is granted by implication or otherwise under any intellectual property or other rights of TOSHIBA CORPORATION or others.
- The information contained herein is subject to change without notice.

TERMINAL EXPLANATION (Terminal Voltage Shows the Typical Value at $T_a = 25^\circ\text{C}$, $V_{CC} = 5\text{V}$, $SW_3 = \text{OFF}$, $SW_9 = \text{GND}$, and Non-signal Test Circuit)

PIN No.	CHARACTERISTIC	INTERNAL CIRCUIT	DC VOLTAGE (V)	
			FM	AM
1	AM RF IN		1.95	1.95
2	<p>AM S-SENS</p> <ul style="list-style-type: none"> ● AM IF Count Output Sensitivity Adjust Terminal ● Bias Terminal for AM IF/DET Out Switch Circuit <p>$V_2 = \text{GND} \rightarrow \text{AM DET Out (pin 19)}$ $V_2 = \text{Vstb} \rightarrow \text{AM IF Out (pin 19)}$</p>		$\left. \begin{matrix} 0.5 \\ \text{at } SW_9 \\ = \text{Vstb} \\ 1.45 \\ R_2 = \\ 10\text{k}\Omega \end{matrix} \right\}$	$\left. \begin{matrix} 0.5 \\ \text{at } SW_9 \\ = \text{Vstb} \\ 1.45 \\ R_2 = \\ 10\text{k}\Omega \end{matrix} \right\}$
3	<p>FM S-SENS</p> <ul style="list-style-type: none"> ● FM IF Count Output Sensitivity Adjust Terminal 		$\left. \begin{matrix} 0 \\ R_3 = \\ 10\text{k}\Omega \end{matrix} \right\}$	$\left. \begin{matrix} 0 \\ R_3 = \\ 10\text{k}\Omega \end{matrix} \right\}$

PIN No.	CHARACTERISTIC	INTERNAL CIRCUIT	DC VOLTAGE (V)	
			FM	AM
4	AM OSC		1.95	1.95
5	AM OSC OUT		5.0	4.75
6	VCC	—	5.0	5.0
7	AGC		0.01	0.01
8	GND	—	0	0
9	IF OUT / REQ ● IF Count Output Terminal ● IF Count Output / FM ST DET Mute Circuit Control Terminal $V_9 = V_{CC} \rightarrow \text{ON}$ $V_9 = \text{Open} \rightarrow \text{OFF}$		—	—

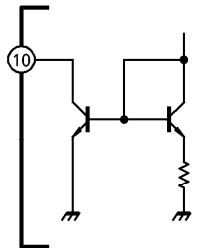
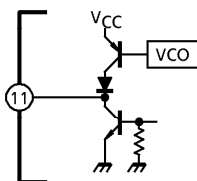
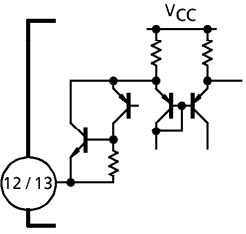
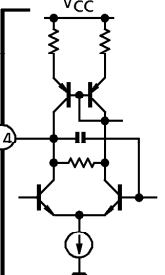
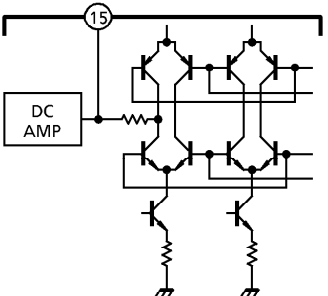
PIN No.	CHARACTERISTIC	INTERNAL CIRCUIT	DC VOLTAGE (V)	
			FM	AM
10	TUN LED		—	—
11	ST LED		—	—
12	R-OUT		1.4	1.4
13	L-OUT		1.4	1.4
14	VCO		4.3	4.3
15	<p>LPF2</p> <ul style="list-style-type: none"> ● LPF Terminal for Synchronous Detector ● VCO Stop Terminal <p>V₁₅ = GND → VCO Stop</p>		3.6	3.6

PIN No.	CHARACTERISTIC	INTERNAL CIRCUIT	DC VOLTAGE (V)	
			FM	AM
16	<p>LPF1</p> <ul style="list-style-type: none"> ● LPF Terminal for Phase Detector ● Bias Terminal for AM/FM Switch Circuit <p>$V_{16} = \text{GND} \rightarrow \text{AM}$ $V_{16} = \text{Open} \rightarrow \text{FM}$</p>		3.6	0
17	MPX IN		1.4	1.4
18	<p>AM DET OUT</p> <ul style="list-style-type: none"> ● AM DET/IF OUT <p>$V_2 = \text{GND} \rightarrow \text{AM DET OUT}$ $V_2 = \text{Vstb} \rightarrow \text{AM IF OUT}$</p>	<p>(a) Low, (b) High : AM DET OUT (a) High, (b) Low : AM IF OUT</p>	1.44	<p>1.5 (at $\text{SW}_9 = \text{Vstb}$) 1.3</p>
19	FM DET OUT		1.2	1.5

PIN No.	CHARACTERISTIC	INTERNAL CIRCUIT	DC VOLTAGE (V)	
			FM	AM
20	QUAD		1.1	1.5
21	AM IF IN		1.95	1.95
22	Vstb		1.95	1.95
23	MIX OUT		5.0	5.0
24	FM IF IN		1.95	1.95

APPLICATION NOTE

1. How to control the IF count output signal (pin⑨ output)

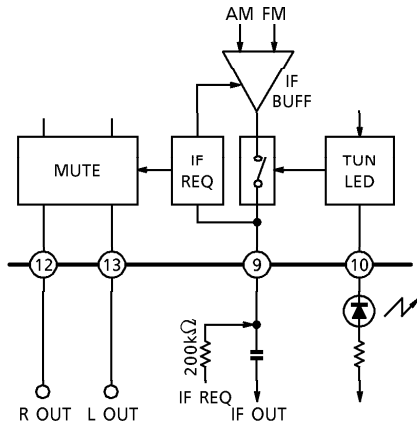

		TUN LED	
		ON	OFF
V _g	H	Come on	Non output
	OPEN	Non output	Non output

		MUTE CIRCUIT	
V _g	H	ON	
	OPEN	OFF	

- Whether or not there is the IF count output signal (pin⑨ output) is determined by the AND of the pin⑨ control voltage : V_g and tuning LED ON/OFF switching.

In the condition of

$$\left(\begin{array}{l} V_g : \text{High (Active High, } V_{TH} = 2V \text{ (Typ.))} \\ \text{TUN LED} : \text{ON (} V_{in} \geq V_L + 2\text{dB (Typ.))} \end{array} \right)$$

the IF count output signal come out from the pin⑨.

- The signal waveform is FM : rectangular, AM : differential wave, and the level is 500mV_{p-p} (Typ.).
- Mute circuit is action by the pin⑨ control voltage : V_g (at high) in matrix output circuit.

2. How to adjust the IF count output sensitivity

- The IF count output sensitivity (search sensitivity) can be adjusted by varying the IF Amp. gain for FM and varying the mixer gain for AM.
- However, this is only possible at the Auto-Tuning mode (external voltage supplied to pin⑨ is at high level). The original gain returns while receiving a broadcast station (supplied voltage to pin⑨ is at low level).

- The gain loss of FM IF Amp. (Typ.)

R ₃	
0Ω	10kΩ
-25dB	0dB

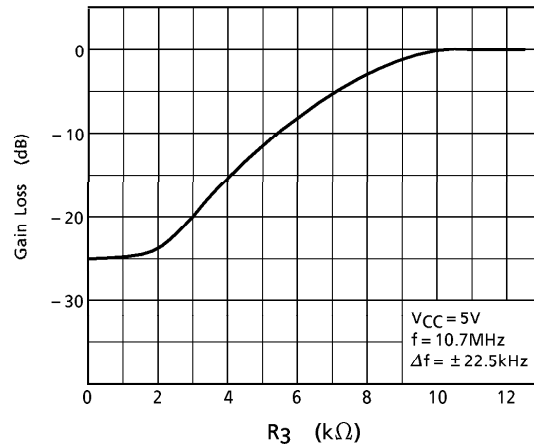

- The gain loss of AM mixer (Typ.)

	R ₂	
	0Ω	10kΩ (Note)
Det. Output Mode	-29dB	0dB
IF Amp. Output Mode	-29dB	0dB

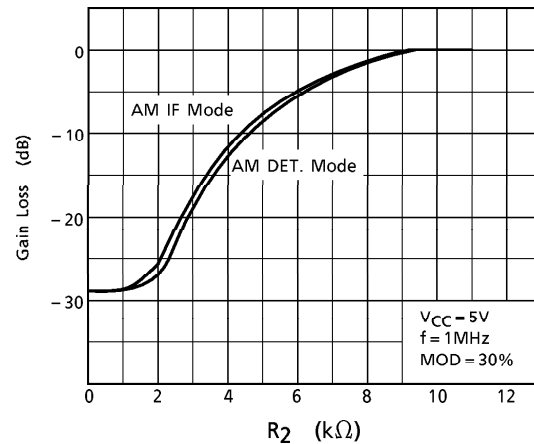

(Note) It is necessary to set up the value of R₂ under 20kΩ.

When the R₂ is over 20kΩ, it is feared that the mode can not change.

3. How to control the AM IF output signal (pin¹⁸ output)

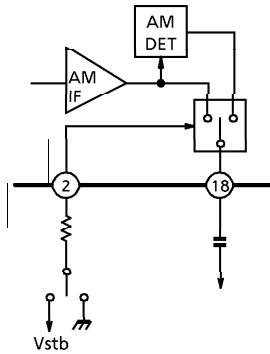

		PIN ¹⁸ OUTPUT SIGNAL
V ₂	GND	AM DET OUT
	Vstb	AM IF OUT

4. AM local oscillator buffer output

- The output impedance of AM local oscillator buffer output pin (pin⁵) is 750Ω (Typ.).
- It is possible to reduce the output level to add the resistance between the pin⁵ and V_{CC} line. The signal waveform is the rectangular wave, and the level is 500mV_{p-p}. (f_{OSC} = 1.45MHz (Typ.))
- The higher local oscillation frequency (f_{OSC}) to be, the lower buff output level to be owing to the load capacity. So, in the case that it is connected to other circuits, take care of the input capacity of these circuits and stray capacity of wire.

5. FM detector circuit

For the FM detector circuit, detector coil is able to use instead of ceramic discriminator. Recommended circuit and recommended coil are as follows. In this case, please take care that V_{in} (lim.) fall a little.

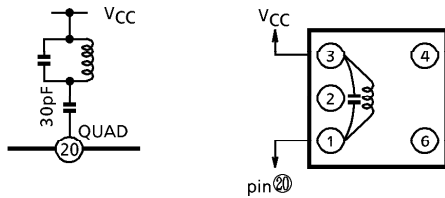

TEST FREQUENCY	C ₀ (pF)	Q ₀	TURNS				WIRE (mm φ)	REF.
			1-2	2-3	1-3	4-6		
10.7MHz	100	100	—	—	12	—	0.12 UEW	SUMIDA ELECTRIC Co., Ltd. 2153-4095-189 or Equivalent

6. FM / AM switch and forced monaural switch

- FM / AM switchover and stereo / forced monaural switchover are done by pin^⑩ and pin^⑮.
- FM / AM switch (pin^⑩)

(V_{16} : Low (Active Low, $V_{TH} = 1.0V$ (Typ.)	→AM
	V_{16} : OPEN	→FM
- Stereo / forced monaural switch (pin^⑮)

(V_{15} : Low (Active Low, $V_{TH} = 1.0V$ (Typ.)	→Forced Monaural
	V_{15} : OPEN	→Stereo

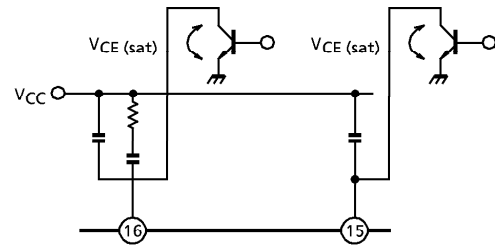

MAXIMUM RATINGS (Ta = 25°C)

CHARACTERISTIC		SYMBOL	RATING	UNIT
Supply Voltage		V _{CC}	14	V
LED Current		I _{LED}	10	mA
LED Voltage		V _{LED}	14	V
Power Dissipation	TA2057N	P _D (Note)	1200	mW
	TA2057F		400	
Operating Temperature		T _{opr}	- 25~75	°C
Storage Temperature		T _{stg}	- 55~150	°C

(Note) Derated above 25°C in the proportion of 9.6mW/°C for TA2057N and of 3.2mW/°C for TA2057F.

ELECTRICAL CHARACTERISTICS

Unless otherwise specified, $T_a = 25^\circ\text{C}$, $V_{CC1} = 5\text{V}$, $SW_3 = \text{OFF}$, $SW_9 = \text{GND}$, $SW_{10} = 1$
 FM IF : $f = 10.7\text{MHz}$, $\Delta f = \pm 22.5\text{kHz}$, $f_m = 1\text{kHz}$
 AM : $f = 1\text{MHz}$, $\text{MOD} = 30\%$, $f_m = 1\text{kHz}$
 FM ST DET : $f_m = 1\text{kHz}$

CHARACTERISTIC		SYMBOL	TEST CIRCUIT	TEST CONDITION	MIN.	TYP.	MAX.	UNIT
Supply Current		$I_{CC}(\text{FM})$	1	FM Mode, $V_{in} = 0$	—	20	26	mA
		$I_{CC}(\text{AM})$	1	AM Mode, $V_{in} = 0$	—	20	26	
FM IF	Input Limiting Voltage	$V_{in}(\text{lim})$	1	-3dB Limiting Point	38	43	48	$\text{dB}\mu\text{V}$ EMF
	Recovered Output Voltage	V_{OD}	1	$V_{in} = 80\text{dB}\mu\text{V}$ EMF	70	100	140	mV_{rms}
	Signal To Noise Ratio	S/N	1	$V_{in} = 80\text{dB}\mu\text{V}$ EMF	—	70	—	dB
	Total Harmonic Distortion	THD	1	$V_{in} = 80\text{dB}\mu\text{V}$ EMF	—	0.2	—	%
	AM Rejection Ratio	AMR	1	$V_{in} = 80\text{dB}\mu\text{V}$ EMF	—	50	—	dB
	LED ON Sensitivity	V_L	1	$I_L = 1\text{mA}$	43	48	53	$\text{dB}\mu\text{V}$ EMF
	IF Count Output Voltage	$V_{IF}(\text{FM})$	1	$SW_3 : \text{ON}$, $V_{in} = 80\text{dB}\mu\text{V}$ EMF	350	500	—	$\text{mV}_{\text{p-p}}$
IF Count Output Sensitivity	$IF_{\text{sens}}(\text{FM})$	1	$SW_3 : \text{ON}$, $SW_1 : 0\Omega$	—	73	—	$\text{dB}\mu\text{V}$ EMF	
			$SW_3 : \text{ON}$, $SW_1 : 5.1\text{k}\Omega$	—	62	—		
AM	Gain	G_V	1	$V_{in} = 23\text{dB}\mu\text{V}$ EMF	35	70	105	mV_{rms}
	Recovered Output Voltage	V_{OD}	1	$V_{in} = 60\text{dB}\mu\text{V}$ EMF	70	100	140	mV_{rms}
	Signal To Noise Ratio	S/N	1	$V_{in} = 60\text{dB}\mu\text{V}$ EMF	—	45	—	dB
	Total Harmonic Distortion	THD	1	$V_{in} = 60\text{dB}\mu\text{V}$ EMF	—	0.5	—	%
	LED ON Sensitivity	V_L	1	$I_L = 1\text{mA}$	19	24	29	$\text{dB}\mu\text{V}$ EMF
	Local OSC Buff Output Voltage	$V_{OSC}(\text{AM})$	1	$f_{OSC} = 1.45\text{MHz}$	350	500	—	$\text{mV}_{\text{p-p}}$
			2	$f_{OSC} = 27\text{MHz}$	—	500	—	
	AM IF Output Voltage For AM Stereo	$V_{IF}(\text{ST})$	1	$SW_9 : V_{\text{stb}}$, $\text{MOD} = 0\%$ $V_{in} = 60\text{dB}\mu\text{V}$ EMF, $SW_{10} : 2$	800	1100	1400	$\text{mV}_{\text{p-p}}$
	IF Count Output Voltage	$V_{IF}(\text{AM})$	1	$SW_3 : \text{ON}$, $V_{in} = 60\text{dB}\mu\text{V}$ EMF	350	500	—	$\text{mV}_{\text{p-p}}$
IF Count Output Sensitivity	$IF_{\text{sens}}(\text{AM})$	1	$SW_3 : \text{ON}$, $SW_2 : 0\Omega$	—	54	—	$\text{dB}\mu\text{V}$ EMF	
			$SW_3 : \text{ON}$, $SW_2 : 5.1\text{k}\Omega$	—	30	—		

CHARACTERISTIC		SYMBOL	TEST CIR-CUIT	TEST CONDITION	MIN.	TYP.	MAX.	UNIT	
FM ST DET	Max. Composite Input Voltage	V_{in} MAX (STEREO)	1	L + R = 90%, P = 10% THD = 3%, SWg→LPF : ON	—	800	—	mV _{rms}	
	Separation	Sep.	1	L + R = 180mV _{rms} P = 20mV _{rms} SWg→LPF : ON	$f_m = 100\text{Hz}$	—	45	—	dB
					$f_m = 1\text{kHz}$	35	45	—	
					$f_m = 10\text{kHz}$	—	45	—	
	Total Harmonic Distortion	Monaural	THD (MONO)	1	$V_{in} = 200\text{mV}_{rms}$ (MONO)	—	0.05	—	%
		Stereo	THD (ST)		L + R = 180mV _{rms} P = 20mV _{rms} SWg→LPF : ON	—	0.05	—	
	Voltage Gain		G_V (FM ST DET)	1	$V_{in} = 200\text{mV}_{rms}$ (MONO)	-2	0	2	dB
	Channel Balance		C.B.	1	$V_{in} = 200\text{mV}_{rms}$ (MONO)	-2	0	2	dB
	Stereo LED Sensitivity	ON	V_L (ON)	1	Pilot Input	—	10	18	mV _{rms}
		OFF	V_L (OFF)			3	8	—	
Stereo LED Hystersis		V_H	1	to LED turn OFF from LED turn On	—	2	—	mV _{rms}	
Capture Range		C.R.	1	P = 20mV _{rms}	—	± 1.3	—	%	
Signal To Noise Ratio		S/N	1	$V_{in} = 200\text{mV}_{rms}$ (MONO)	—	78	—	dB	

TEST CIRCUIT 1

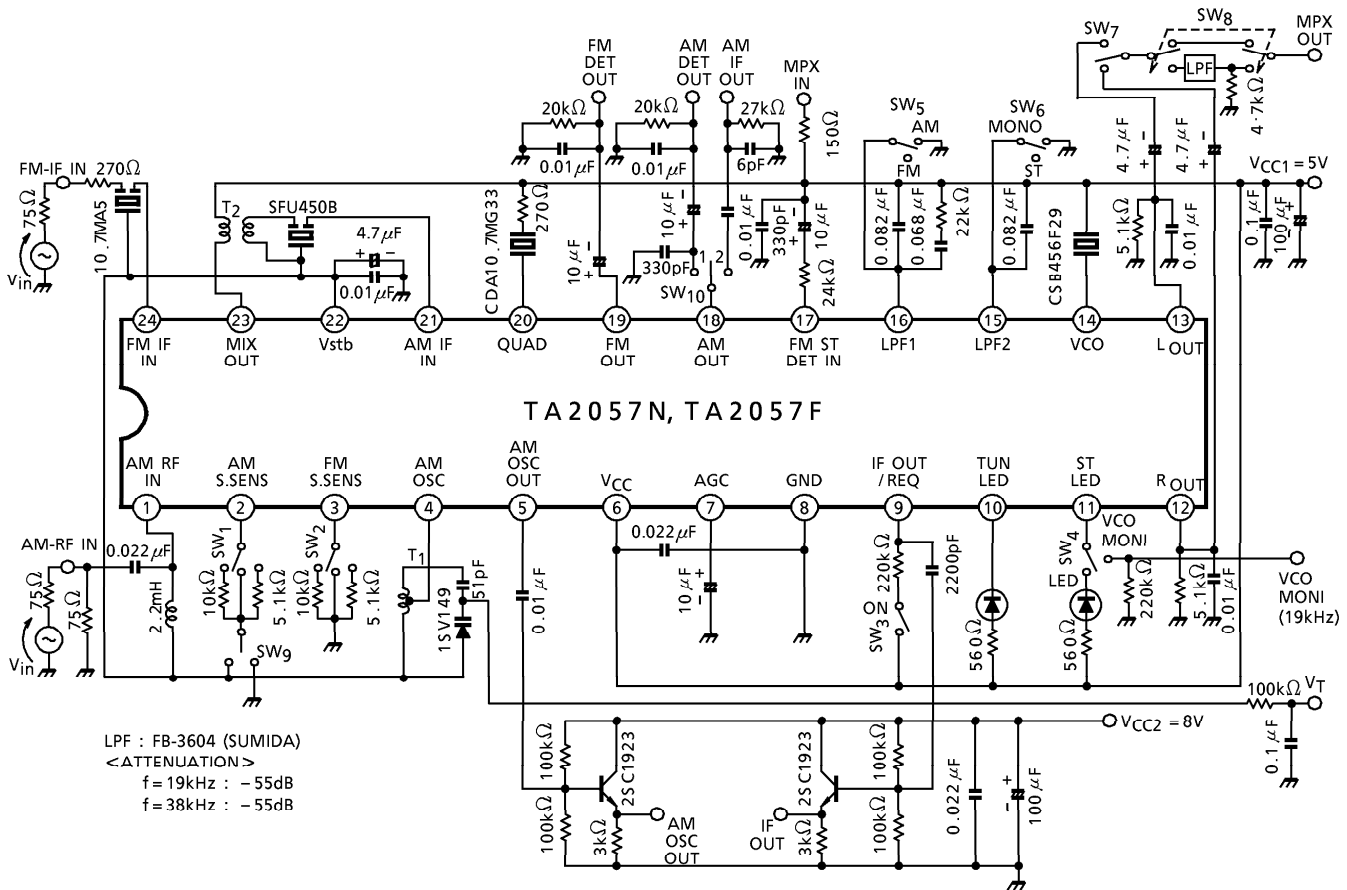

COIL DATA (TEST CONDITION 1)

COIL No.	f	L (μH)	C ₀ (pF)	Q ₀	TURN				WIRE (mm φ)	REF. (COIL No.)
					1-2	2-3	1-3	4-6		
T ₁ AM OSC	796kHz	288	—	115	13	73	—	—	0.08 UEW	Ⓢ4147-1356-038 ⓉA7BRS-12552Y ⓂMJ-3273-3
T ₂ AM IFT	455kHz	—	180	120	—	—	180	15	0.06 UEW	Ⓢ2150-2162-165 Ⓣ7MES-11368N ⓂMJ-3337-1

- Ⓢ : SUMIDA ELECTRIC Co., Ltd.
- Ⓣ : TOKO Co., Ltd.
- Ⓜ : MITSUMI ELECTRIC Co., Ltd.

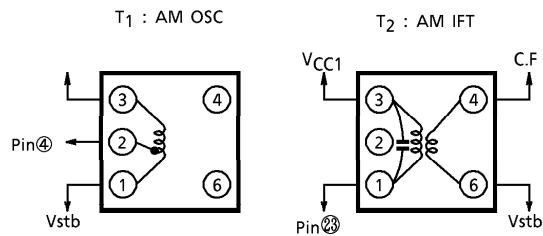

TEST CIRCUIT 2

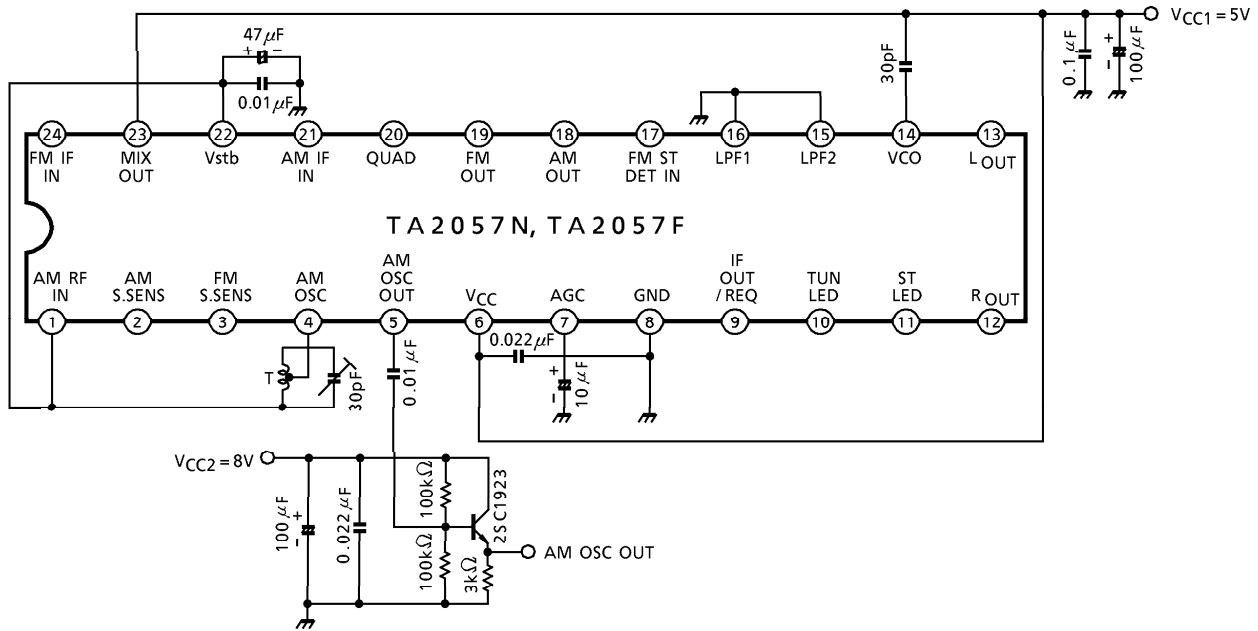

COIL DATA (TEST CIRCUIT 2)

COIL No.	f	L (μ H)	C ₀ (pF)	Q ₀	TURN				WIRE (mm ϕ)	REF. (COIL No.)
					1-2	2-3	1-3	4-6		
T AM OSC	7.96MHz	1.4	—	84	1	6	7	—	0.08 UEW	Ⓣ7PL-1344Y

Ⓣ : TOKO Co., Ltd.

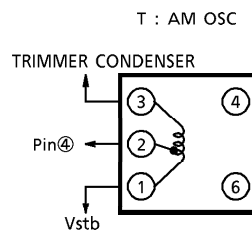

OUTLINE DRAWING
SDIP24-P-300-1.78

Unit : mm

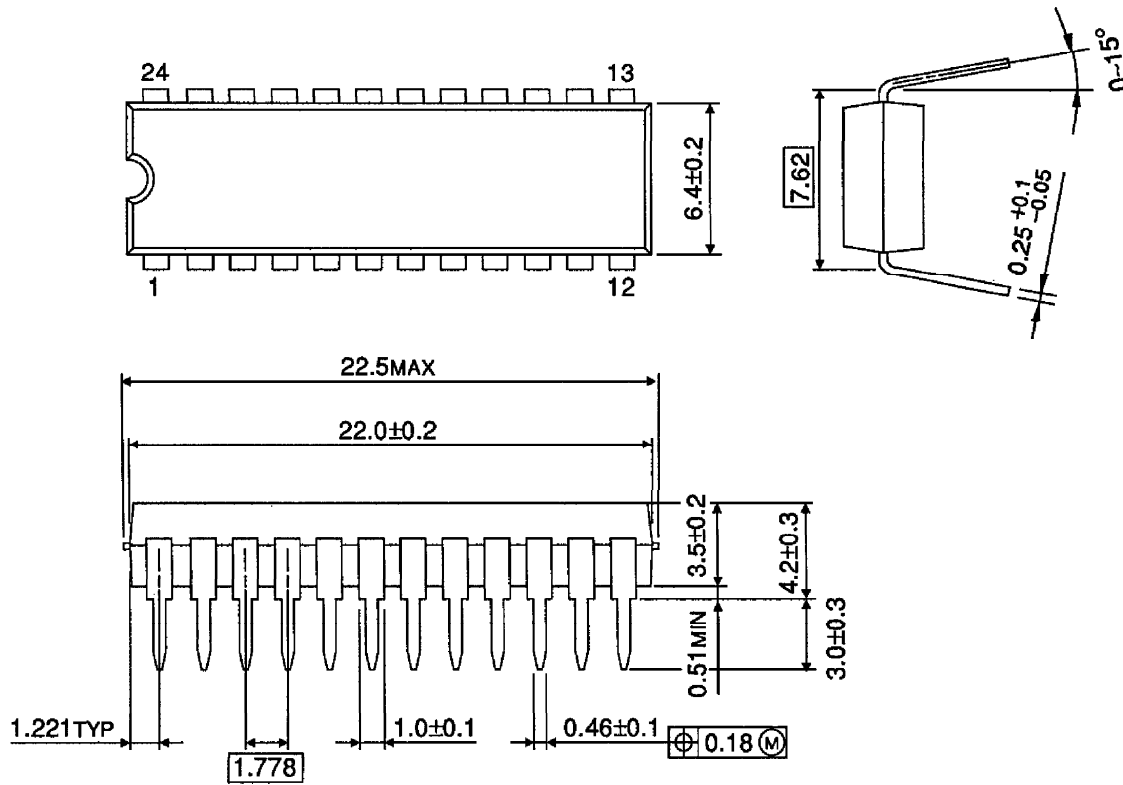

Weight : 1.2g (Typ.)

OUTLINE DRAWING
SSOP24-P-300-1.00

Unit : mm

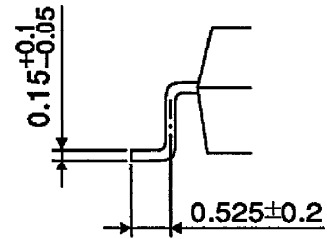
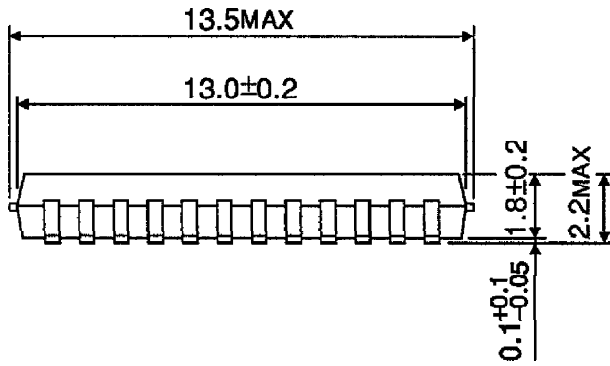
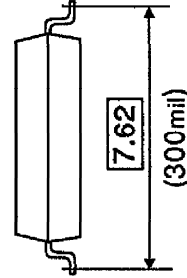
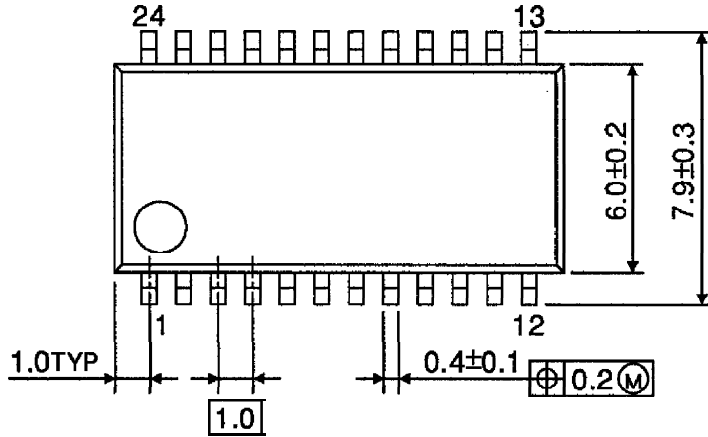

Weight : 0.31g (Typ.)