

SY89230U



3.2GHz Precision, LVPECL $\div 3$, $\div 5$ Clock Divider

Preliminary

General Description

The SY89230U is a precision, low jitter 3.2 GHz $\div 3$, $\div 5$ clock divider with an LVPECL output. The differential input includes Micrel's unique, 3-pin internal termination architecture that allows the input to interface to any differential signal (AC- or DC-coupled) as small as 100mV (200mV_{PP}) without any level shifting or termination resistor networks in the signal path. The outputs are 800mV, 100K-compatible LVPECL with fast rise/fall times guaranteed to be less than 200ps.

The SY89230U operates from a 2.5V $\pm 5\%$ or 3.3V $\pm 10\%$ supply and is guaranteed over the full industrial temperature range of -40°C to $+85^{\circ}\text{C}$. The SY89230U is part of Micrel's high-speed, Precision Edge[®] product line.

All support documentation can be found on Micrel's web site at: www.micrel.com.

Block Diagram

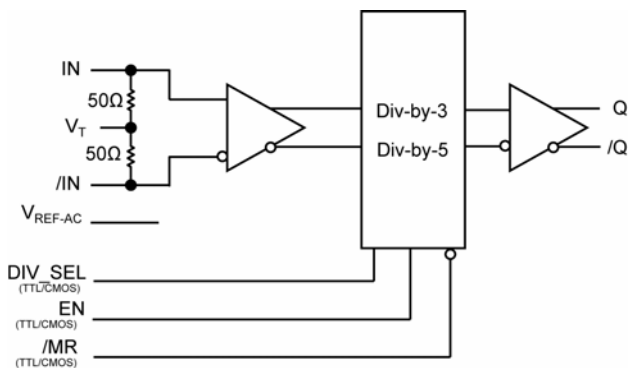

Precision Edge[®]

Features

- Accepts a high-speed input and provides a precision $\div 3$ and $\div 5$ sub-rate, LVPECL output
- Guaranteed AC performance over temperature and supply voltage:
 - DC-to >3.2 GHz throughput
 - $< 850\text{ps}$ Propagation Delay (In-to-Q)
 - $< 200\text{ps}$ Rise/Fall times
- Ultra-low jitter design:
 - $< 1\text{ps}_{\text{RMS}}$ random jitter
 - $< 1\text{ps}_{\text{RMS}}$ cycle-to-cycle jitter
 - $< 10\text{ps}_{\text{SP}}$ total jitter (clock)
 - $< 0.7\text{ps}_{\text{RMS}}$ MUX crosstalk induced jitter
- Unique patented internal termination and VT pin accepts DC- and AC-coupled inputs (CML, PECL, LVDS)
- Wide input voltage range VCC to GND
- 800mV LVPECL output
- TBD% to TBD% Duty Cycle
- 2.5V $\pm 5\%$ or 3.3V $\pm 10\%$ supply voltage
- -40°C to $+85^{\circ}\text{C}$ industrial temperature range
- Available in 16-pin (3mm x 3mm) MLF[®] package

Applications

- Fail-safe clock protection

Markets

- LAN/WAN
- Enterprise servers
- ATE
- Test and measurement

Precision Edge is a registered trademark of Micrel, Inc.
MLF and *MicroLeadFrame* are registered trademarks of Amkor Technology.

Micrel Inc. • 2180 Fortune Drive • San Jose, CA 95131 • USA • tel +1 (408) 944-0800 • fax + 1 (408) 474-1000 • <http://www.micrel.com>

July. 18, 2007

M9999-071807-A
hbwhelp@micrel.com or (408) 955-1690

Ordering Information⁽¹⁾

Part Number	Package Type	Operating Range	Package Marking	Lead Finish
SY89230UMG	MLF-16	Industrial	230U with Pb-Free bar-line Indicator	NiPdAu Pb-Free
SY89230UMGTR ⁽²⁾	MLF-16	Industrial	230U with Pb-Free bar-line Indicator	NiPdAu Pb-Free

Notes:

1. Contact factory for die availability. Dice are guaranteed at T_A = 25°C, DC Electricals Only.
2. Tape and Reel.

Pin Configuration

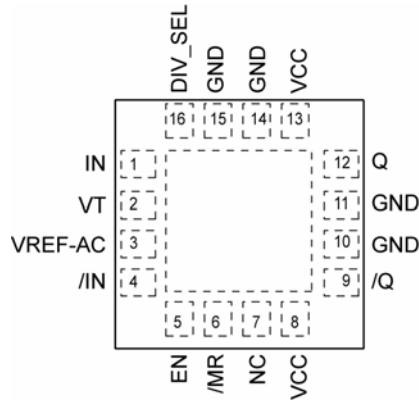

16-Pin MLF[®] (MLF-16)

Pin Description

Pin Number	Pin Name	Pin Function
1, 4	IN, /IN	Differential Input: This input pair is the differential signal input to the device, which accepts AC- or DC-coupled signal as small as 100mV. The input internally terminates to a VT pin through 50Ω and has level shifting resistors of 3.72 kΩ to VCC. This allows a wide input voltage range from VCC to GND. See Figure 3a, Simplified Differential Input Stage for details. Note that this input will default to a valid (either HIGH or LOW) state if left open. See “Input Interface Applications” subsection.
2	VT	Input Termination Center-Tap: Each side of the differential input pair terminates to the VT pin. The VT pin provides a center-tap for the input (IN, /IN) to a termination network for maximum interface flexibility. See “Input Interface Applications” section for more details.
3	VREF-AC	Reference Voltage: This output biases to $V_{CC}-1.2V$. It is used for AC-coupling inputs IN and /IN. Connect VREF-AC directly to the VT pin. Bypass with 0.01μF low ESR capacitor to VCC. Due to limited drive capability, the VREF-AC pin is only intended to drive its respective VT pin. Maximum sink/source current is ±0.5mA. See “Input Interface Applications” subsection.
5	EN	Single-ended Input: This TTL/CMOS-compatible input disables and enables the output. It is internally connected to a 25kΩ pull-up resistor and will default to a logic HIGH state if left open. When disabled, Q goes LOW and /Q goes HIGH. EN being synchronous, outputs will be enabled/disabled after a rising and a falling edge of the input clock. $V_{TH} = V_{CC}/2$.
6	/MR	Single-ended Input: This TTL/CMOS-compatible input, when pulled LOW, asynchronously sets Q output LOW and /Q output HIGH. Note that this input is internally connected to a 25kΩ pull-up resistor and will default to logic HIGH state if left open. $V_{TH} = V_{CC}/2$.
7	NC	No Connect
8, 13	VCC	Positive Power Supply: Bypass with 0.1μF in parallel with 0.01μF low ESR capacitors as close to the VCC pins as possible.
12, 9	Q, /Q	Differential Output: The LVPECL output swing is typically 800mV and is terminated with 50Ω to $V_{CC}-2V$. See the “Truth Table” below for the logic function.
10, 11, 14,15	GND, Exposed Pad	Ground: Ground and exposed pad must be connected to a ground plane that is the same potential as the ground pins.
16	DIV_SEL	Single-ended Input: This TTL/CMOS-compatible input selects divide-by-3 when pulled LOW and divide-by-5 when pulled HIGH. Note that this input is internally connected to a 25kΩ pull-up resistor and will default to logic HIGH state if left open. $V_{TH} = V_{CC}/2$.

Truth Table

Inputs			Outputs	
DIV_SEL	EN	/MR	Q	/Q
X	X	0	0	1
0	1	1	÷3	÷3
1	1	1	÷5	÷5
X	0	1	0	1

Absolute Maximum Ratings⁽¹⁾

Supply Voltage (V_{CC}) -0.5V to +4.0V
 Input Voltage (V_{IN}) -0.5V to V_{CC}
 LVPECL Output Current (I_{OUT}).....
 Continuous 50mA
 Surge..... 100mA
 Current (V_T)
 Source or sink current on V_T pin..... ± 100 mA
 Input Current
 Source or sink current on (IN, /IN) ± 50 mA
 Current (V_{REF-AC})
 Source/Sink Current on V_{REF-AC} ⁽⁴⁾ ± 0.5 mA
 Maximum Operating Junction Temperature.....125°C
 Lead Temperature (soldering, 20 sec.)+260°C
 Storage Temperature (T_s).....-65°C to 150°C

Operating Ratings⁽²⁾

Supply Voltage (V_{CC})..... +2.375V to +2.625V
 +3.0V to +3.6V
 Ambient Temperature (T_A)..... -40°C to +85°C
 Package Thermal Resistance⁽³⁾
 MLF[®] (θ_{JA})
 Still-Air 75°C/W
 MLF[®] (ψ_{JB})
 Junction-to-Board.....33°C/W

DC Electrical Characteristics⁽⁵⁾

$T_A = -40^\circ\text{C}$ to $+85^\circ\text{C}$, unless otherwise stated.

Symbol	Parameter	Condition	Min	Typ	Max	Units
V_{CC}	Power Supply		2.375	2.5	2.625	V
			3.0	3.3	3.6	V
I_{CC}	Power Supply Current	No load, max V_{CC}		62	85	mA
R_{IN}	Input Resistance (IN-to- V_T)		45	50	55	Ω
R_{DIFF_IN}	Differential Input Resistance (IN-to-/IN)		90	100	110	Ω
V_{IH}	Input High Voltage (IN, /IN)		1.2		V_{CC}	V
V_{IL}	Input Low Voltage (IN, /IN)		0		$V_{IH}-0.1$	V
V_{IN}	Input Voltage Swing (IN, /IN)	See Figure 2a. Note 6.	0.1		1.0	V
V_{DIFF_IN}	Differential Input Voltage Swing IN-/IN	See Figure 2b.	0.2			V
V_{IN_FSI}	Input Voltage Threshold that Triggers FSI			30	100	mV
V_{REF-AC}	Output Reference Voltage		$V_{CC}-1.3$	$V_{CC}-1.2$	$V_{CC}-1.1$	V
V_{T_IN}	Voltage from Input to V_T				1.28	V

Notes:

1. Permanent device damage may occur if absolute maximum ratings are exceeded. This is a stress rating only and functional operation is not implied at conditions other than those detailed in the operational sections of this data sheet. Exposure to absolute maximum rating conditions for extended periods may affect device reliability.
2. The data sheet limits are not guaranteed if the device is operated beyond the operating ratings.
3. Package thermal resistance assumes exposed pad is soldered (or equivalent) to the devices most negative potential on the PCB. θ_{JA} and ψ_{JB} values are determined for a 4-layer board in still air unless otherwise stated.
4. Due to limited drive capability use for input of the same package only.
5. The circuit is designed to meet the DC specifications shown in the above table after thermal equilibrium has been established.
6. V_{IN} (max) is specified when V_T is floating.

LVPECL Outputs DC Electrical Characteristics⁽⁷⁾

$V_{CC} = 2.5V \pm 5\%$ or $3.3V \pm 10\%$; $R_L = 50\Omega$ to $V_{CC}-2V$; $T_A = -40^\circ C$ to $+85^\circ C$, unless otherwise stated.

Symbol	Parameter	Condition	Min	Typ	Max	Units
V_{OH}	Output HIGH Voltage Q, /Q		$V_{CC}-1.145$		$V_{CC}-0.895$	V
V_{OL}	Output LOW Voltage Q, /Q		$V_{CC}-1.945$		$V_{CC}-1.695$	V
V_{OUT}	Output Voltage Swing Q, /Q	See Figure 2a.	550	800	950	mV
V_{DIFF_OUT}	Differential Output Voltage Swing Q, /Q	See Figure 2b.	1100	1600		mV

LVTTL/CMOS DC Electrical Characteristics⁽⁷⁾

$V_{CC} = 2.5V \pm 5\%$ or $3.3V \pm 10\%$; $T_A = -40^\circ C$ to $+85^\circ C$, unless otherwise stated.

Symbol	Parameter	Condition	Min	Typ	Max	Units
V_{IH}	Input HIGH Voltage		2.0			V
V_{IL}	Input LOW Voltage				0.8	V
I_{IH}	Input HIGH Current		-125		30	μA
I_{IL}	Input LOW Current		-300			μA

Note:

7. The circuit is designed to meet the DC specifications shown in the above table after thermal equilibrium has been established.

AC Electrical Characteristics⁽⁸⁾

$V_{CC} = 2.5V \pm 5\%$ or $3.3V \pm 10\%$; $R_L = 50\Omega$ to $V_{CC}-2V$; $T_A = -40^\circ C$ to $+85^\circ C$, unless otherwise stated.

Symbol	Parameter	Condition	Min	Typ	Max	Units
f_{MAX}	Maximum Input Operating Frequency	$V_{OUT} \geq 200mV$	3.2			GHz
t_w	Minimum Pulse Width		100			ps
t_{pd}	Differential Propagation Delay In-to-Q	Note 9	450	650	850	ps
	/MR(H-L)-to-Q		250	450	650	ps
t_{RR}	Reset Recovery Time	/MR(L-H)-to-IN	300			ps
t_s EN	Set-up Time	EN-to-CLK	Note 10	50		ps
t_h EN	Hold Time	CLK-to-EN	Note 10	250		ps
t_{skew}	Part-to-Part Skew	Note 10			300	ps
t_{JITTER}	Clock					
	Random Jitter	Note 11			1	$\mu SRMS$
	Cycle-to-Cycle Jitter	Note 12			1	$\mu SRMS$
	Total Jitter	Note 13			10	μS_{PP}
t_r, t_f	Output Rise/Fall Time (20% to 80%)	At full output swing.	90		200	ps
	Duty Cycle (input)		40		60	%
	Duty Cycle (output)	$f \leq 2GHz$, Note 14	47		53	%
		$f > 2GHz$, Note 14	45		55	%

Notes:

- High-frequency AC-parameters are guaranteed by design and characterization.
- The propagation delay is function of the rise and fall times at IN. Input $t_r / t_f \leq 300ps$ (20% to 80%). See "Typical Operating Characteristics" for details.
- Set-up and hold times apply to synchronous applications that intend to enable/disable before the next clock cycle. For asynchronous applications, set-up and hold do not apply.
- Random Jitter is measured with a K28.7 character pattern, measured at $<f_{MAX}$.
- Cycle-to-Cycle Jitter definition: the variation of periods between adjacent cycles, $T_n - T_{n-1}$ where T is the time between rising edges of the output signal.
- Total Jitter definition: with an ideal clock input of frequency $<f_{MAX}$, no more than one output edge in 10^{12} output edges will deviate by more than the specified peak-to-peak jitter value.
- For Input Duty Cycle different from 50%, see "Output Duty Cycle Equation" in "Functional Description" subsection.

Functional Description

Output Duty Cycle Equation

For divide by 3, output Duty Cycle is:

$$1 + \frac{X}{100} \\ 3$$

For divide by 5, output Duty Cycle is:

$$2 + \frac{X}{100} \\ 5$$

X = input Duty Cycle

Enable (EN)

EN is a synchronous TTL/CMOS-compatible input that enables/disables the outputs based on the input to this pin. Internal 25kΩ pull-up resistor defaults the input to logic HIGH if left open. Input switching threshold is $V_{CC}/2$.

The Enable function operates as follows:

1. The enable/disable function is synchronous so that the clock outputs will be enabled or disabled following a rising and a falling edge of the input clock when switching from EN = LOW to EN = HIGH.

However, when switching from EN = HIGH to EN = LOW, the clock outputs will be disabled following an input clock rising edge and an output clock falling edge.

2. The enable/disable function always guarantees the full pulse width at the output before the clock outputs are disabled, non-dependending on the divider ratio. Refer to Figure 1b for examples.

Divider Operation

The divider operation uses both the rising and falling edge of the input clock. For divide by 3, the falling edge of the second input clock cycle will determine the falling edge of the output. For divide by 5, the falling edge of the third input clock cycle. Refer to Figure 1c.

Timing Diagrams

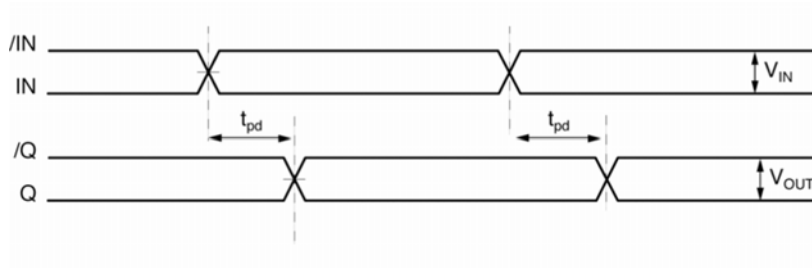

Figure 1a. Propagation Delay

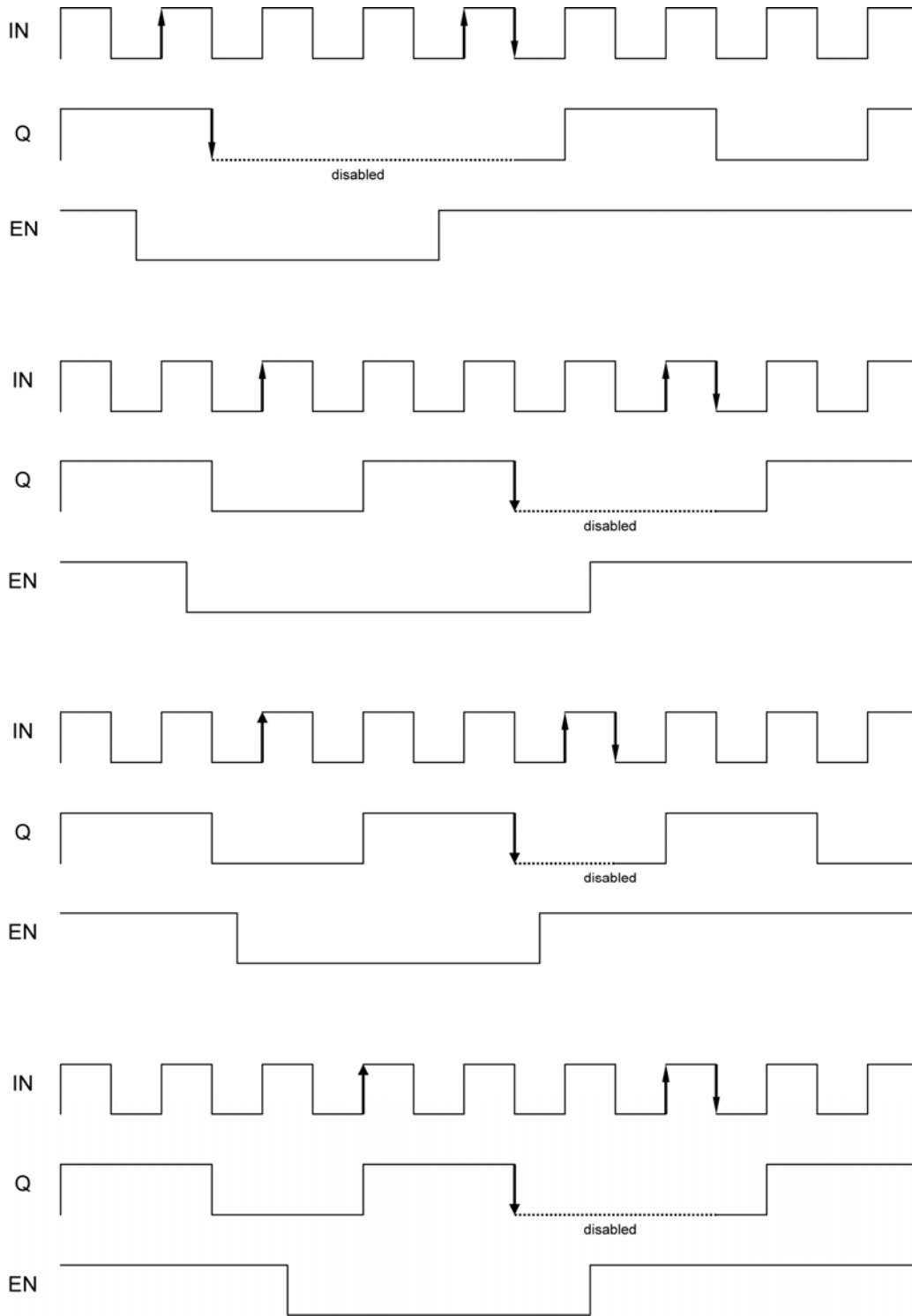

Figure 1b. Enable Output Timing Diagram Examples

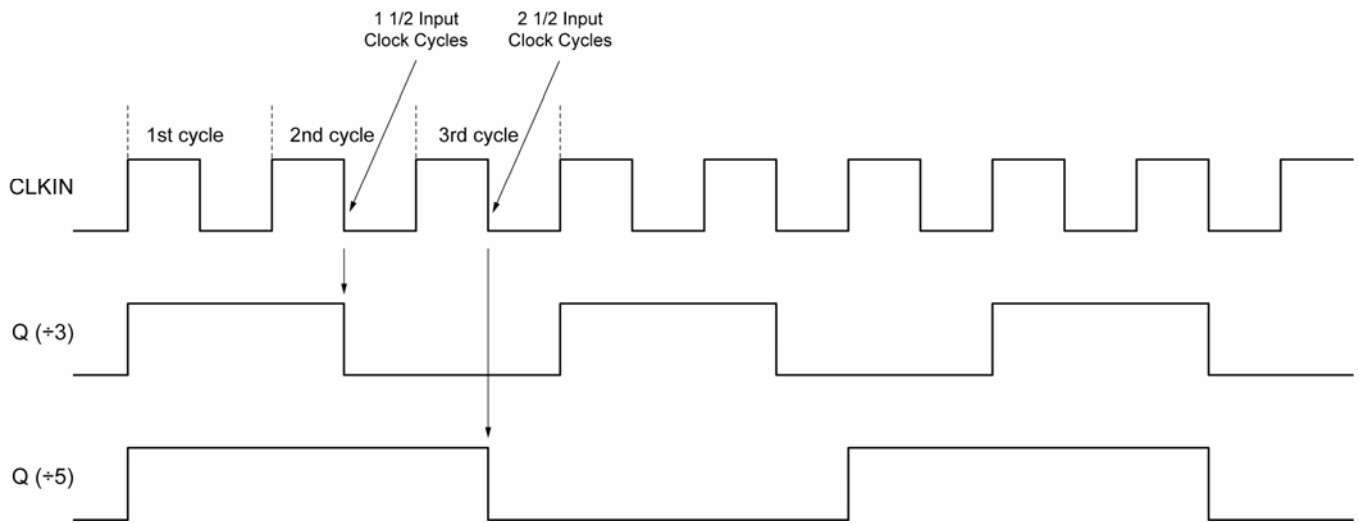
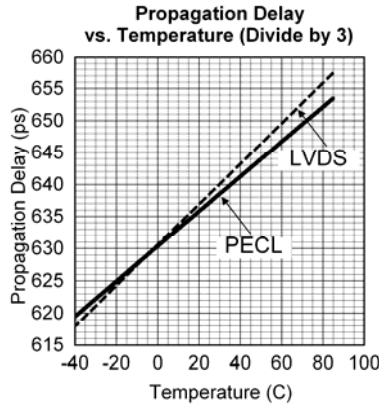
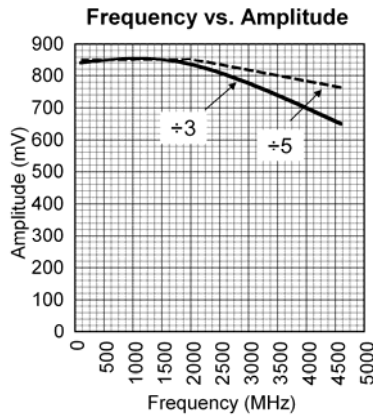

Figure 1c. Divider Operation Timing Diagram

Typical Operating Characteristics

$V_{CC} = 3.3V$, $GND = 0V$, $t_r / t_f \leq 300ps$, $R_L = 50\Omega$ to $V_{CC}-2V$; $T_A = 25^\circ C$, unless otherwise stated.



Functional Characteristics

$V_{CC} = 2.5V$, $GND = 0V$, $V_{IN} = 100mV$, $Q = \text{Divide by } 3$, $t_r/t_f \leq 300ps$, $R_L = 50\Omega$ to $V_{CC}-2V$; $T_A = 25^\circ C$, unless otherwise stated.

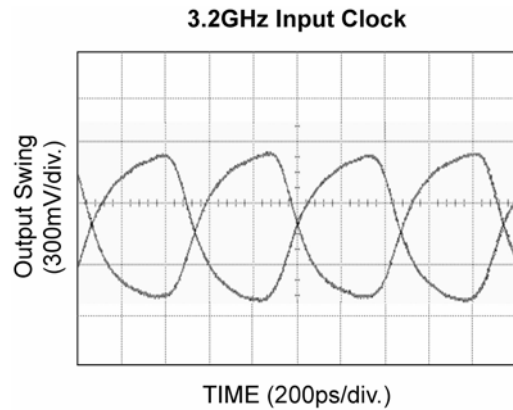
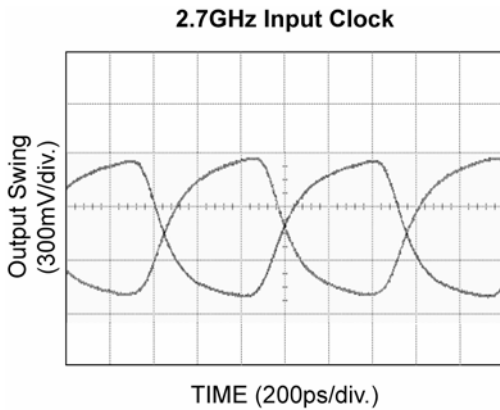
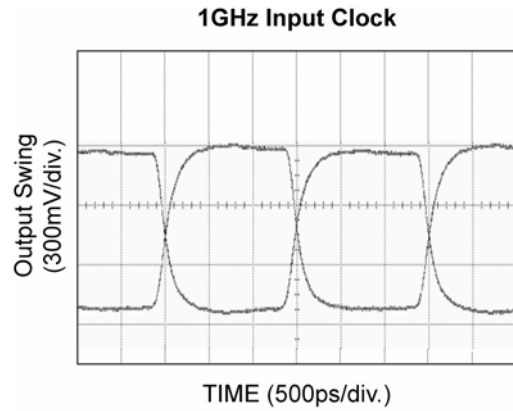
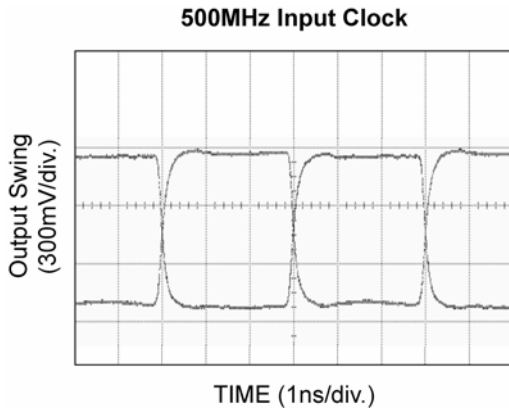

Single-Ended and Differential Swings

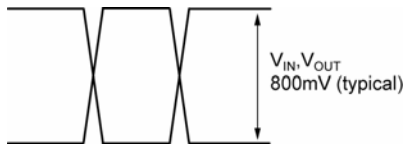

Figure 2a. Single-Ended Voltage Swing

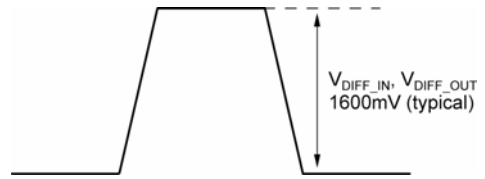

Figure 2b. Differential Voltage Swing

Input and Output Stages

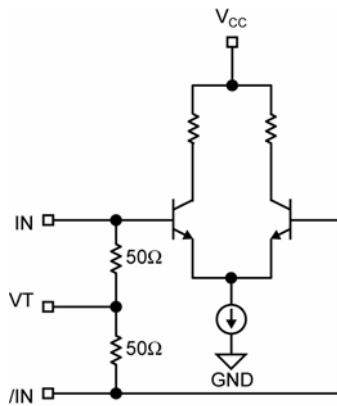

Figure 3a. Simplified Differential Input Stage

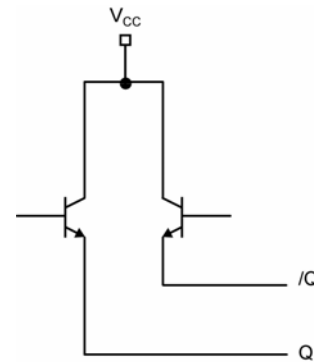

Figure 3b. Simplified Differential Output Stage

Input Interface Applications

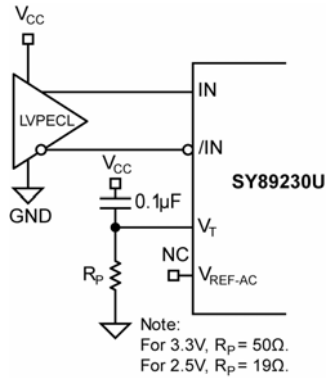

Figure 4a. LVPECL Interface (DC-Coupled)

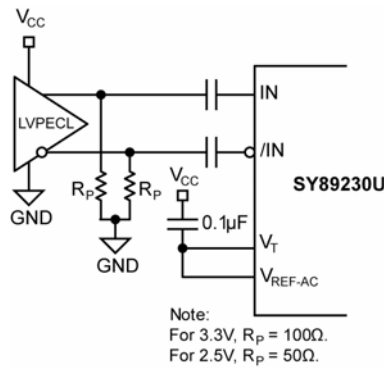
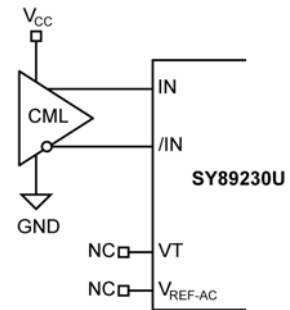

Figure 4b. LVPECL Interface (AC-Coupled)



Option: may connect V_T to V_{CC}

Figure 4c. CML Interface (DC-Coupled)

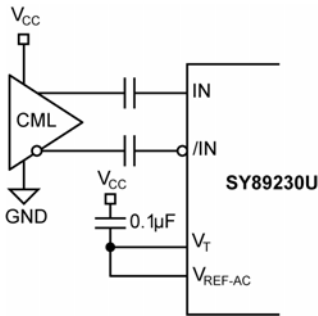

Figure 4d. CML Interface (AC-Coupled)

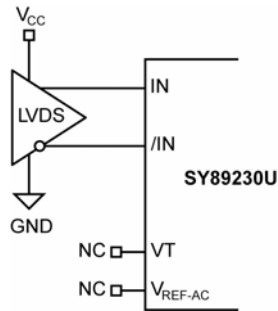

Figure 4e. LVDS Interface (DC-Coupled)

PECL Output Interface Applications

PECL has a high input impedance, a very low output impedance (open emitter), and a small signal swing which results in low EMI. PECL is ideal for driving 50Ω- and 100Ω-controlled impedance transmission lines. There are several techniques for terminating the PECL output: parallel termination-thevenin equivalent, parallel termination (3-resistor), and AC-coupled termination. Unused output pairs may be left floating. However, single-ended outputs must be terminated, or balanced.

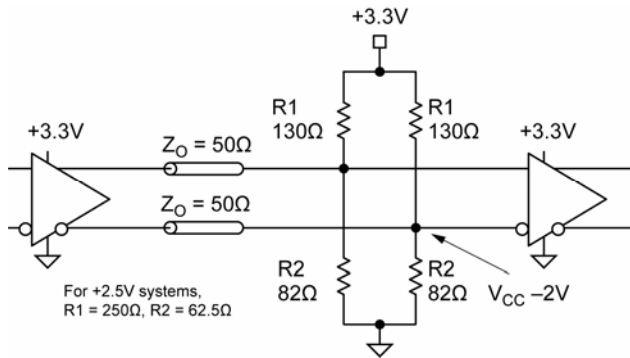
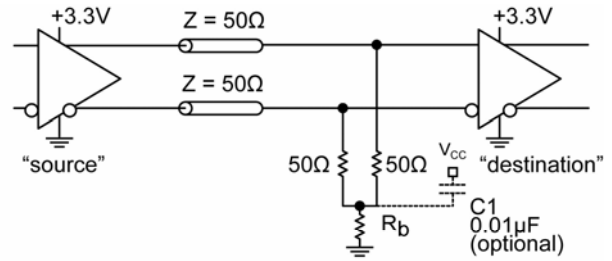

Figure 5a. Parallel Termination-Thevenin Equivalent



Notes:

1. Power-saving alternative to Thevenin termination.
2. Place termination resistors as close to destination inputs as possible.
3. R_b resistor sets the DC bias voltage, equal to V_{CC} - 2V.
4. For 2.5V systems, R_b = 19Ω. For 3.3V systems, R_b = 50Ω.

Figure 5b. Parallel Termination (3-Resistor)

Related Product and Support Documentation

Part Number	Function	Datasheet Link
SY89228U	1GHz Precision, LVPECL ÷3, ÷5 Clock Divider with Fail-Safe Input and Internal Termination	
SY89229U	1GHz Precision, LVDS ÷3, ÷5 Clock Divider with Fail-Safe Input and Internal Termination	
SY89231U	3.2GHz Precision, LVDS ÷3, ÷5 Clock Divider	
	MLF® Application Note	www.amkor.com/products/notes_papers/MLFAppNote.pdf
HBW Solutions	New Products and Applications	www.micrel.com/product-info/products/solutions.shtml

Package Information

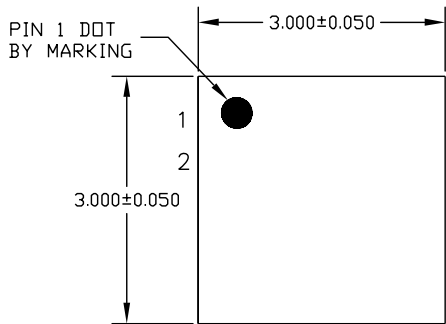

TOP VIEW

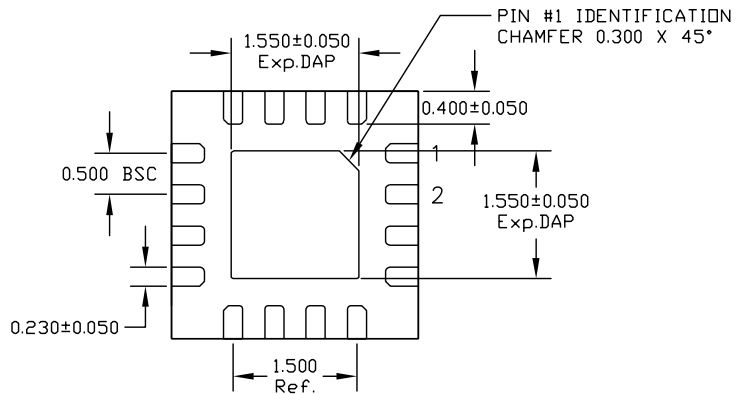

BOTTOM VIEW

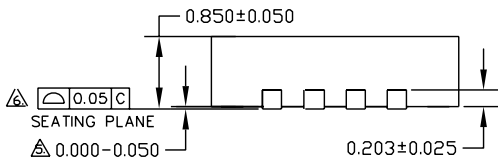

SIDE VIEW

- NOTE:
1. ALL DIMENSIONS ARE IN MILLIMETERS.
 2. MAX. PACKAGE WARPAGE IS 0.05 mm.
 3. MAXIMUM ALLOWABLE BURRS IS 0.076 mm IN ALL DIRECTIONS.
 4. PIN #1 ID ON TOP WILL BE LASER/INK MARKED.
- ⚠ APPLIED ONLY FOR TERMINALS.
 - ⚠ APPLIED FOR EXPOSED PAD AND TERMINALS.

16-Pin MicroLeadFrame® (MLF-16)

Packages Notes:

1. Package meets Level 2 Moisture Sensitivity Classification.
2. All parts are dry-packed before shipment.
3. Exposed pad must be soldered to a ground for proper thermal management.

MICREL, INC. 2180 FORTUNE DRIVE SAN JOSE, CA 95131 USA
 TEL +1 (408) 944-0800 FAX +1 (408) 474-1000 WEB <http://www.micrel.com>

The information furnished by Micrel in this data sheet is believed to be accurate and reliable. However, no responsibility is assumed by Micrel for its use. Micrel reserves the right to change circuitry and specifications at any time without notification to the customer.

Micrel Products are not designed or authorized for use as components in life support appliances, devices or systems where malfunction of a product can reasonably be expected to result in personal injury. Life support devices or systems are devices or systems that (a) are intended for surgical implant into the body or (b) support or sustain life, and whose failure to perform can be reasonably expected to result in a significant injury to the user. A Purchaser's use or sale of Micrel Products for use in life support appliances, devices or systems is a Purchaser's own risk and Purchaser agrees to fully indemnify Micrel for any damages resulting from such use or sale.