

267 MHz 1:2 3.3V HCSL/LVDS Fanout Buffer

Features

- Two Differential Pairs of LVDS or HCSL Outputs
- Two Pairs of Differential Inputs Accept LVDS or HCSL Logic Levels
- 267 MHz Maximum Frequency
- Ultra-Low Phase Jitter:
 - 137 fs_{RMS}, 200 MHz (12 kHz - 20 MHz)
 - 153 fs_{RMS}, 156.25 MHz (12 kHz - 20 MHz)
 - 212 fs_{RMS}, 100 MHz (12 kHz - 20 MHz)
- <2 ps Total Jitter (peak-to-peak), 200 MHz (BER = 10⁻¹²)
- 50 ps Output-to-Output Skew
- 3.3V ±5% Power Supply Operation
- -40°C to +85°C Operating Temperature
- Available in 16-pin (3 mm × 3 mm) QFN Lead-Free Package

Applications

- Blade Servers
- Desktop Servers
- Workstations
- Storage Area Networks
- IP Routers and Switches
- Telecom and Datacom
- High Performance Computing

General Description

The SY75572L is a high-speed, fully differential 1:2 clock fanout buffer with a 2:1 input MUX optimized to provide two identical output copies with 137 fs phase jitter and a maximum of 50 ps output-to-output skew. Designed to be used with PCI Express applications, the SY75572L accepts and outputs HCSL or LVDS logic levels.

The SY75572L operates from a 3.3V ±5% power supply and is guaranteed over the full industrial temperature range (-40°C to +85°C). It is available in a 16-pin QFN lead-free package.

The SY75572L is part of Microchip's high-speed, ultra-low jitter, PrecisionEdge™ product line. The SY75572L supports PCIe Gen1-Gen4 requirements.

Package Type

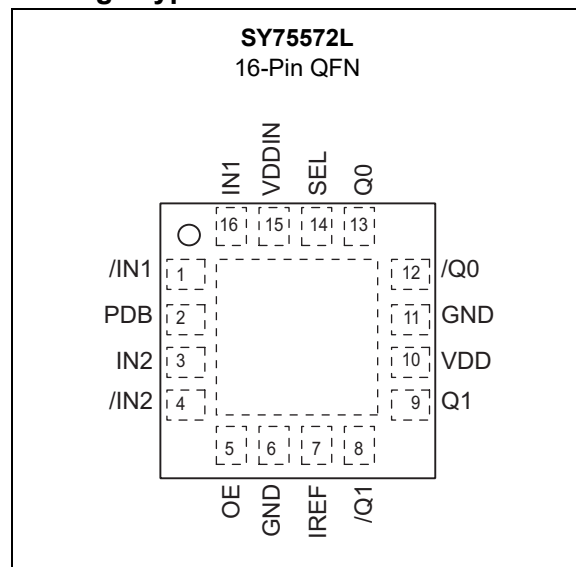

Functional Block Diagram

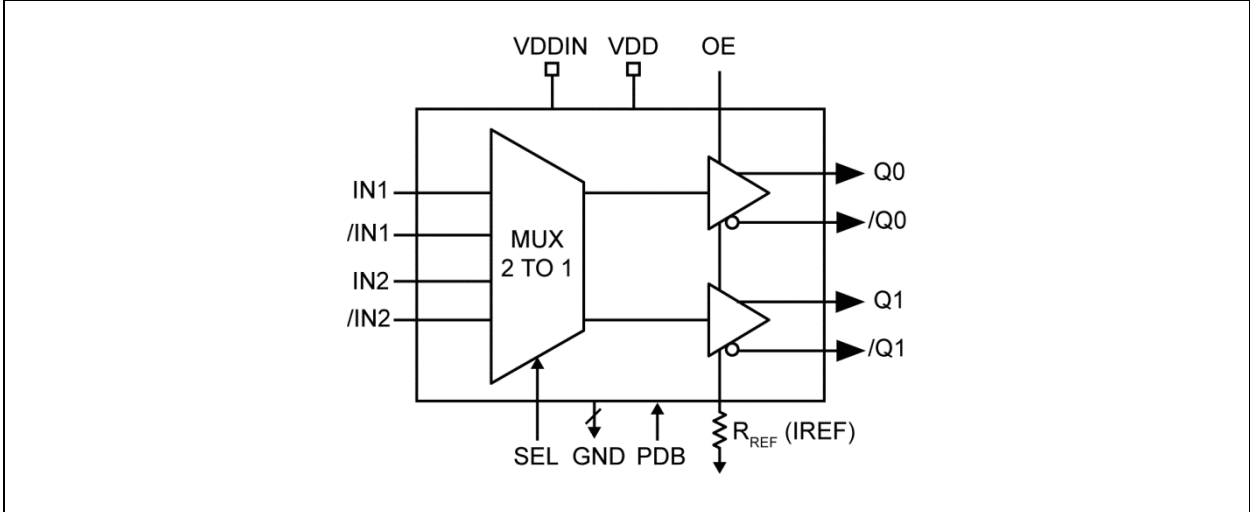

1.0 ELECTRICAL CHARACTERISTICS

Absolute Maximum Ratings †

Supply Voltage, V_{CC} , V_{DDIN}	5.5V
Input Voltage, V_{IN}	-0.5V to V_{DDIN} +0.5V
ESD Protection (Input).....	2 kV

Operating Ratings ††

Supply Voltage, V_{DD} , V_{DDIN}	3.135V to 3.465V
---	------------------

† Notice: Permanent device damage may occur if absolute maximum ratings are exceeded. This is a stress rating only and functional operation is not implied at conditions other than those detailed in the operational sections of this data sheet. Exposure to absolute maximum ratings conditions for extended periods may affect device reliability.

†† Notice: The data sheet limits are not guaranteed if the device is operated beyond the operating ratings.

DC ELECTRICAL CHARACTERISTICS

Electrical Characteristics: $V_{DD} = V_{DDIN} = 3.135V$ to $3.465V$, $T_A = -40^{\circ}C$ to $+85^{\circ}C$, unless otherwise stated.
 $R_{REF} = 475\Omega$. (Note 1)

Parameters	Symbol	Min.	Typ.	Max.	Units	Conditions
Power Supply Voltage Range	V_{DD}, V_{DDIN}	3.135	3.3	3.465	V	—
Input Capacitance	C_{IN}	—	—	6	pF	—
Output Capacitance	C_{OUT}	—	—	5	pF	—
Pin Inductance	L_{PIN}	—	—	4	nH	—
Output Resistance	R_{OUT}	3	—	—	k Ω	—
Pull up Resistance	$R_{PULL-UP}$	—	110	—	k Ω	SEL, PDB, OE
Input High Voltage	V_{IH}	2	—	$V_{DDIN} + 0.3$	V	SEL, PDB, OE
Input Low voltage	V_{IL}	-0.3	—	0.8	V	SEL, PDB, OE
Input High Voltage	V_{IH}	660	750	850	V	HCSL, IN, /IN
Input Low voltage	V_{IL}	-150	0	—	V	HCSL, IN, /IN
Differential Input Voltage Range	V_{IN}	200	350	550	mV	LVDS, IN, /IN
Input Common Mode Voltage	$V_{INPUT\ OFFSET}$	1.125	1.25	1.375	V	LVDS, IN, /IN
Output High Voltage	V_{OH}	660	750	850	mV	HCSL
Output Low Voltage	V_{OL}	-150	0	27	mV	HCSL
Crossing Point Voltage Note 2, Note 3	V_{CROSS}	250	350	550	mV	Absolute
Variation of Crossing Point Voltage Note 2, Note 3, Note 4	$V_{CROSS_VARIATION}$	—	—	140	mV	Variation over all edges
Power Supply Current For $V_{DD} + V_{DDIN}$	I_{DD}	—	42	60	mA	50 Ω , 2 pF
		—	—	0.4		No load, PDB = Low
		—	—	20		OE = Logic Low
Input Leakage Current Note 5	I_{IL}	-5	—	5	μA	$0 < V_{IN} < V_{DDIN}$

Note 1: The circuit is designed to meet the DC specifications shown in the table above after thermal equilibrium has been established.

2: Test setup is $R_L = 50\Omega$ with 2 pF, $R_{REF} = 475\Omega \pm 1\%$.

3: Measurement taken from Q and /Q.

4: Measured at the crossing point where instantaneous voltages of Q and /Q are equal.

5: Inputs with pull-up/pull-down resistances are not included.

AC ELECTRICAL CHARACTERISTICS

Electrical Characteristics: $V_{DD} = V_{DDIN} = 3.135V$ to $3.465V$, $T_A = -40^{\circ}C$ to $+85^{\circ}C$, unless otherwise stated. (Note 1)						
Parameters	Symbol	Min.	Typ.	Max.	Units	Conditions
Maximum Frequency	f_{MAX}	—	—	267	MHz	HCSL
		—	—	100		LVDS
Propagation Delay	t_{PD}	—	2	3	ns	Note 2
Output-to-Output skew	t_{SKEW}	—	—	50	ps	Note 3, Note 4
Output Rise/Fall Times 0.175V to 0.525V / 0.525V to 0.175V	t_r, t_f	150	350	700	ps	At full output swing. 50 Ω , 2 pF
Rise/Fall Time Variation	t_{r/f_VAR}	—	—	125	ps	At full output swing. 50 Ω , 2 pF
Phase Jitter	t_{JITTER}	—	137	—	f_{RMS}	At 200 MHz
		—	153	—	f_{RMS}	At 156.25 MHz
		—	212	—	f_{RMS}	At 100 MHz
Total Jitter	t_{T_JITTER}	—	2	—	ps	BER = 10^{-12} , $T_{DJ} = 0$, at 200 MHz
Output Enable Time	t_{OE_ENABLE}	—	2	—	μs	All outputs
Output Disable Time	$t_{OE_DISABLE}$	—	10	—	ns	All outputs
Duty Cycle	t_{DCY}	45	50	55	%	—

- Note 1:** The circuit is designed to meet the DC specifications shown in the table above after thermal equilibrium as been established.
- 2:** Measured from the differential input crossing point to the differential output crossing point.
- 3:** Output-to-output skew is the difference in time between outputs, receiving data from the same input, for the same temperature, voltage, and transition.
- 4:** This parameter is defined in accordance with JEDEC Standard 65.

TEMPERATURE SPECIFICATIONS

Parameters	Symbol	Min.	Typ.	Max.	Units	Conditions
Temperature Ranges						
Operating Temperature Range	T_A	-40	—	+85	°C	—
Lead Temperature	—	—	—	+260	°C	Soldering, 20 sec.
Storage Temperature Range	T_S	-65	—	+150	°C	—
Package Thermal Resistance (Note 1)						
16-Pin QFN	θ_{JA}	—	59	—	°C/W	Still-Air
	ψ_{JB}	—	38	—	°C/W	Junction-to-board

Note 1: Package thermal resistance assumes exposed pad is soldered (or equivalent) to the device's most negative potential on the PCB. ψ_{JB} and θ_{JA} values are determined for a 4-layer board in still-air number, unless otherwise stated. The circuit is designed to meet the DC specifications shown in the above table after thermal equilibrium has been established.

2.0 PIN DESCRIPTIONS

The descriptions of the pins are listed in [Table 2-1](#).

TABLE 2-1: PIN FUNCTION TABLE

Pin Number	Pin Name	Description
1	/IN1	HCSSLVDS inverted input 1.
2	PDB	PDB = 0 powers down the chip and tri-states outputs. The pin is attached to an internal pull-up resistor.
3	IN2	HCSSLVDS input 2.
4	/IN2	HCSSLVDS inverted input 2.
5	OE	Tri-state outputs. High = enable outputs. Low = disable outputs. Internal pull-up resistor, outputs are enabled by default.
6	GND	Ground.
7	IREF	External resistor R_{REF} between pin IREF and GND controls reference current.
8	/Q1	Inverted Output 1.
9	Q1	Non-inverted Output 1.
10	VDD	3.3V power supply.
11	GND	Ground.
12	/Q0	Inverted Output 0.
13	Q0	Non-inverted Output 0.
14	SEL	SEL = 0 propagates IN2, /IN2 to outputs. SEL = 1 propagates IN1, /IN1 to outputs. Internal pull-up resistors, IN1, /IN1 is selected by default.
15	VDDIN	3.3V power supply.
16	IN1	HCSSLVDS input 1.

3.0 JITTER ANALYSIS

Jitter is defined as the deviation of a signal from its ideal position. Phase noise is the presence of signal energy at frequencies other than the carrier. Random jitter has a Gaussian distribution and is specified as an RMS unit, which is one standard deviation of the distribution. Since Gaussian distribution is unbounded in an infinite sample, no communication system can be completely error free. Instead, communication links are rated with a maximum bit error rate (BER), which is typically around 10^{-12} for high-speed communication equipment. Achieving a desired BER requires accounting for a number of standard deviations of random noise by using the appropriate value for N (see [Table 3-1](#)) in the formula in [Equation 3-1](#).

If routing clock signals, the deterministic jitter is usually negligible and the T_J is dominated by the random jitter. Calculating T_J from R_J using [Equation 3-1](#) gives the values in [Table 3-1](#).

TABLE 3-1: STANDARD DEVIATIONS OF RANDOM NOISE

BER	N	R_J at 200 MHz	T_J at 200 MHz
10^{-10}	12.723	137fs _{RMS}	1.743 ps
10^{-11}	13.412	137fs _{RMS}	1.837 ps
10^{-12}	14.069	137fs _{RMS}	1.927 ps
10^{-13}	14.698	137fs _{RMS}	2.013 ps

EQUATION 3-1:

$$T_J = N \times R_J + D_J$$

Where:

T_J = Total jitter

R_J = Random jitter

D_J = Deterministic jitter

4.0 PHASE NOISE PLOTS

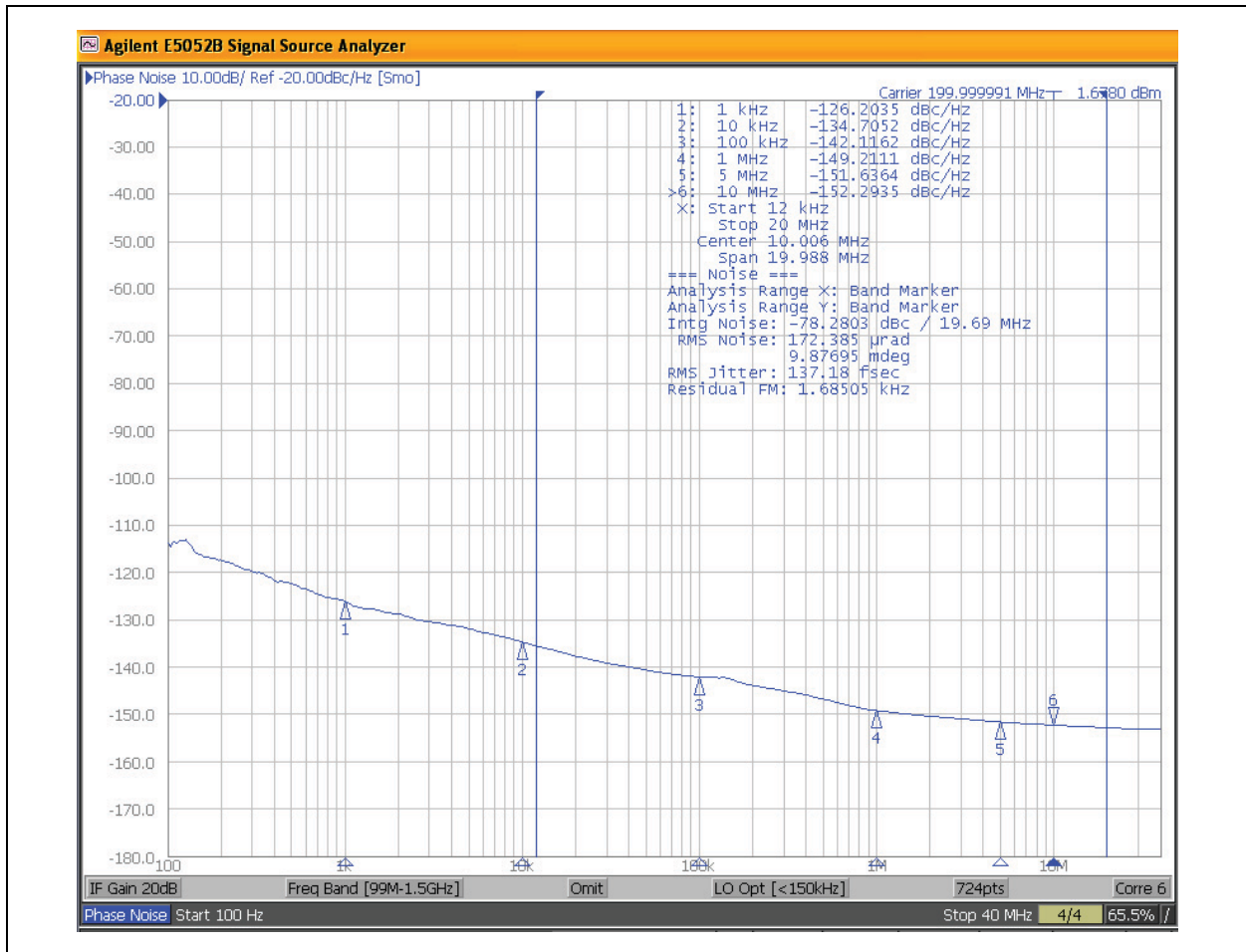

FIGURE 4-1: Phase Jitter = 137 fsRMS, 200 MHz Carrier Frequency; Integration Range: 12 kHz - 20 MHz.

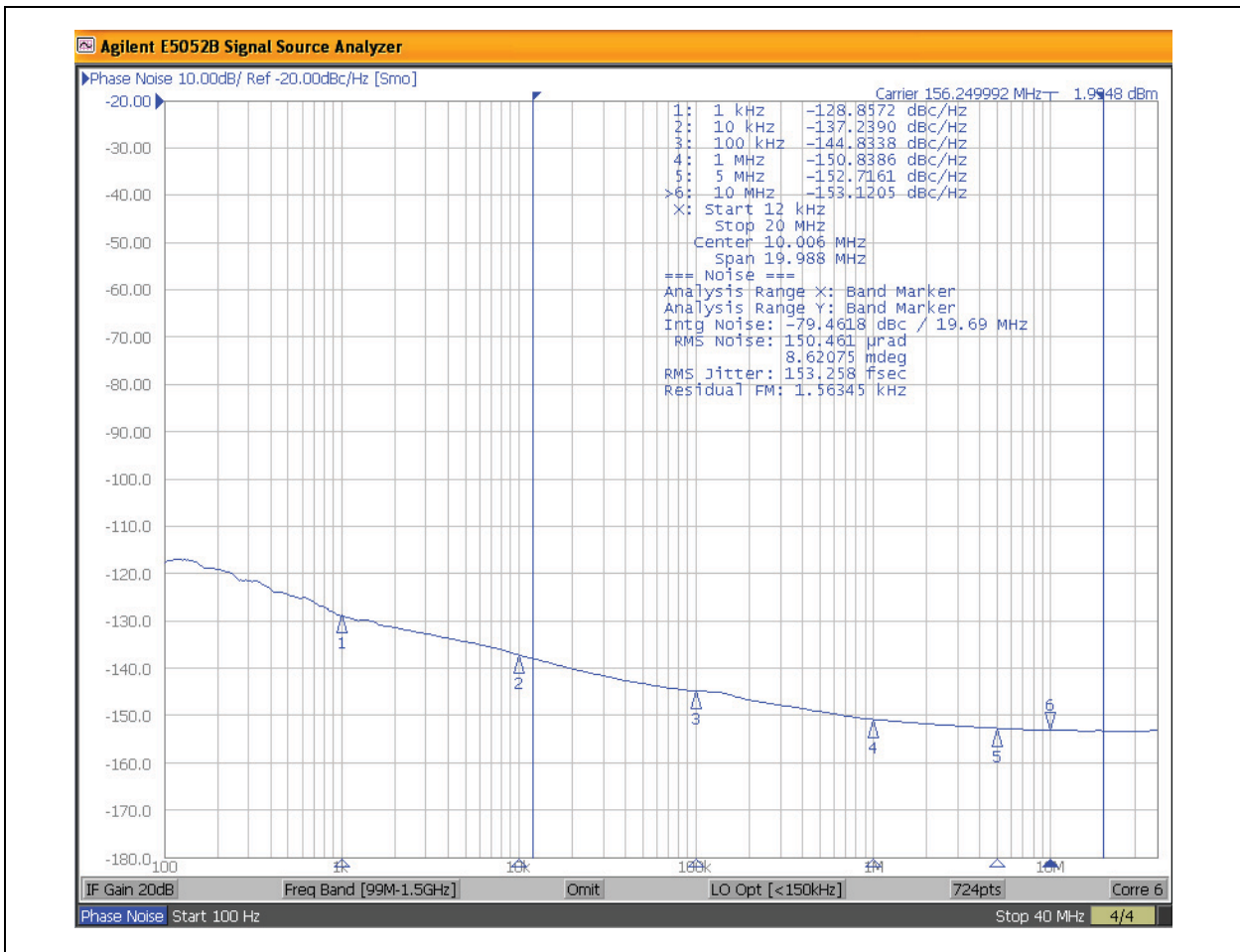

FIGURE 4-2: Phase Jitter = 153 fsRMS, 156.25 MHz Carrier Frequency; Integration Range: 12 kHz - 20 MHz.

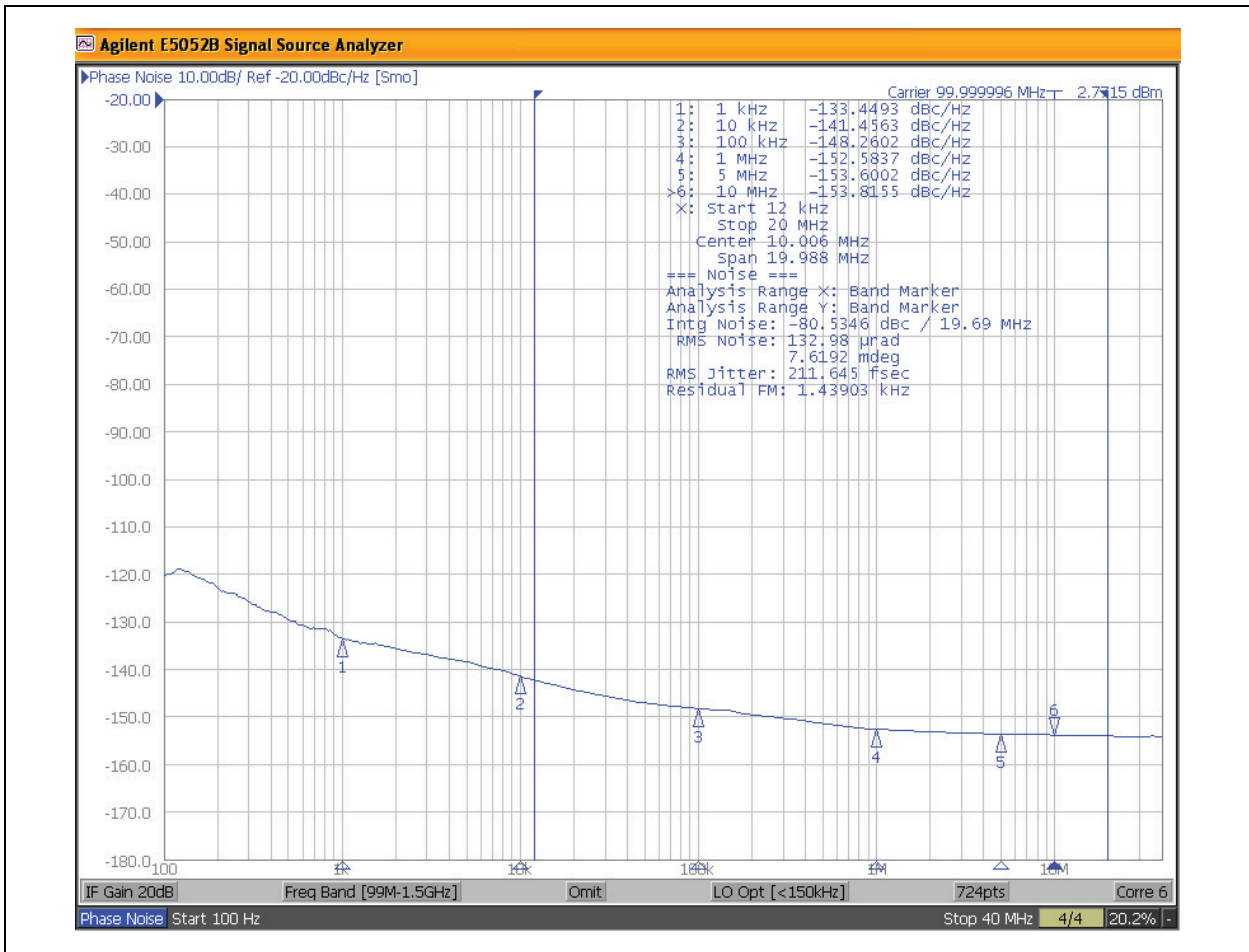

FIGURE 4-3: Phase Jitter = 212 $f_{s_{RMS}}$, 100 MHz Carrier Frequency; Integration Range: 12 kHz - 20 MHz.

5.0 FUNCTIONAL CHARACTERISTICS

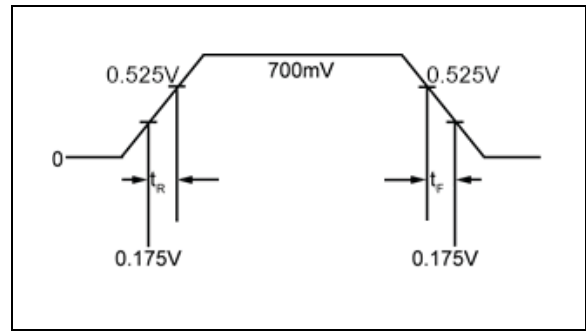
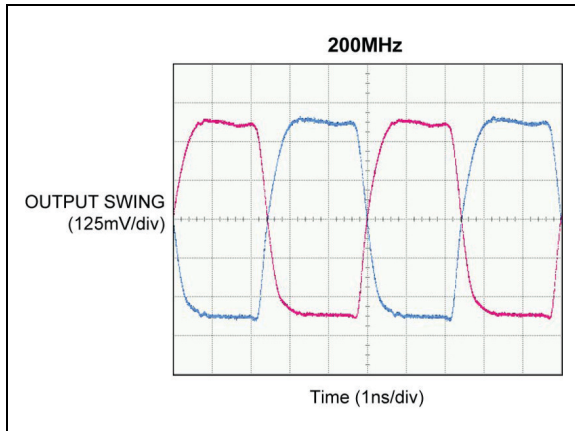
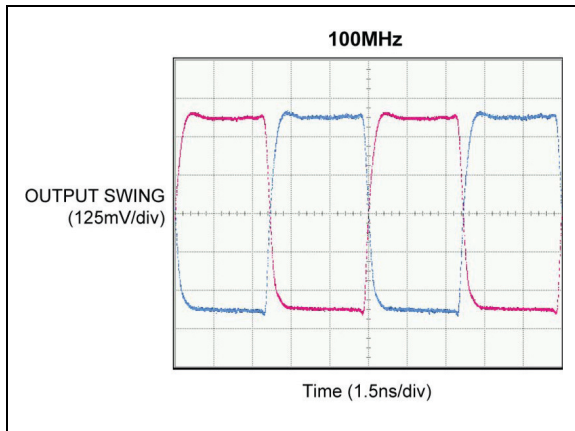

FIGURE 5-1: HCSL Waveform.

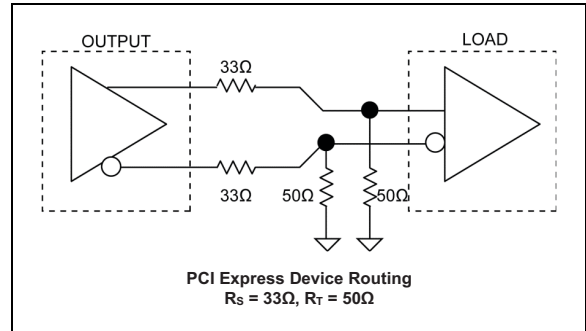

FIGURE 5-2: HCSL Interface Application.

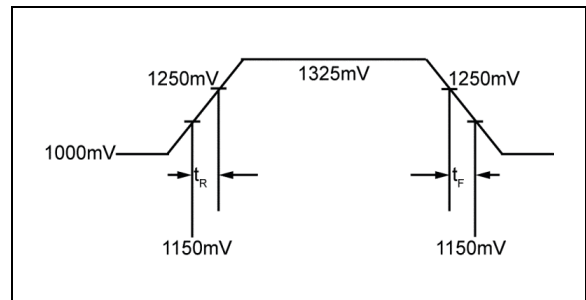

FIGURE 5-3: LVDS Waveform.

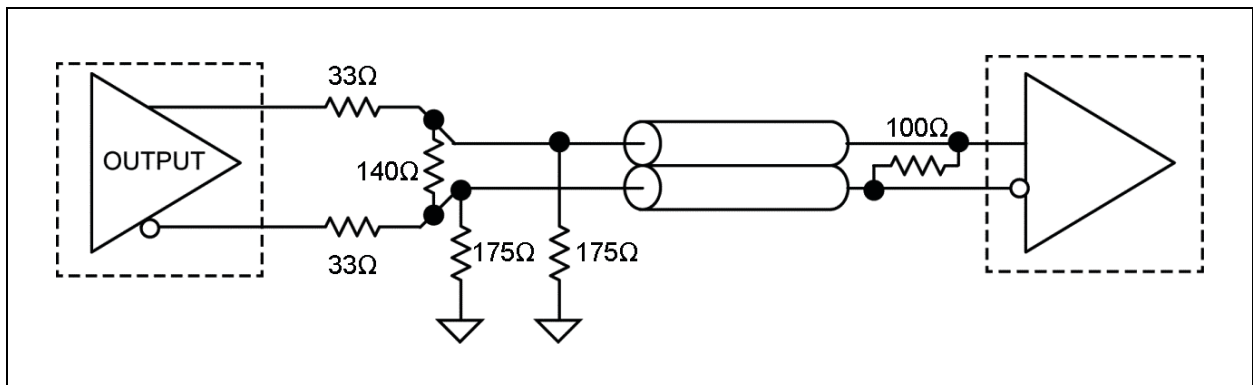
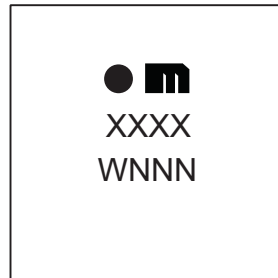

FIGURE 5-4: LVDS Interface Application.

6.0 PACKAGING INFORMATION

6.1 Package Marking Information

16-Lead QFN*



Example

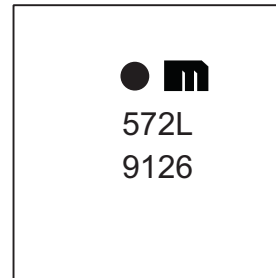

Legend:	XX...X	Product code or customer-specific information
	Y	Year code (last digit of calendar year)
	YY	Year code (last 2 digits of calendar year)
	WW	Week code (week of January 1 is week '01')
	NNN	Alphanumeric traceability code
	(e3)	Pb-free JEDEC® designator for Matte Tin (Sn)
	*	This package is Pb-free. The Pb-free JEDEC designator ((e3)) can be found on the outer packaging for this package.
	●, ▲, ▼	Pin one index is identified by a dot, delta up, or delta down (triangle mark).
Note:	In the event the full Microchip part number cannot be marked on one line, it will be carried over to the next line, thus limiting the number of available characters for customer-specific information. Package may or may not include the corporate logo.	
	Underbar (̄) and/or Overbar (̅) symbol may not be to scale.	

16-Lead QFN Package Outline and Recommended Land Pattern

TITLE

16 LEAD QFN 3x3mm PACKAGE OUTLINE & RECOMMENDED LAND PATTERN

DRAWING #	QFN33-16LD-PL-1	UNIT	MM
------------------	-----------------	-------------	----

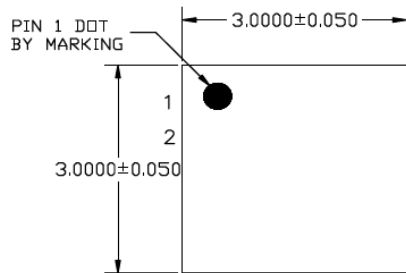

TOP VIEW

NOTE: 1, 2, 3

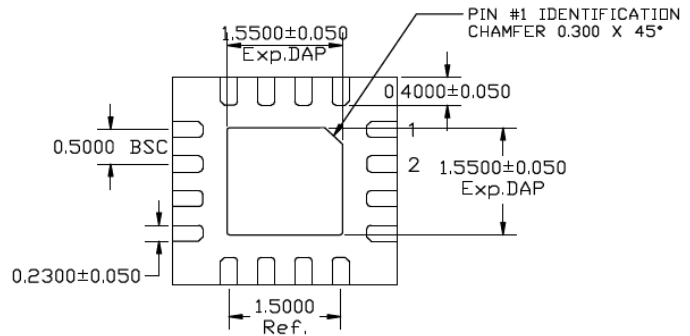

BOTTOM VIEW

NOTE: 1, 2, 3

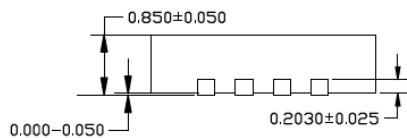

SIDE VIEW

NOTE: 1, 2, 3

NOTE:

1. MAX PACKAGE WARPAGE IS 0.05 MM
2. MAX ALLOWABLE BURR IS 0.076 MM IN ALL DIRECTIONS
3. PIN #1 IS ON TOP WILL BE LASER MARKED
4. RED CIRCLE IN LAND PATTERN INDICATE THERMAL VIA. SIZE SHOULD BE 0.30-0.35 MM IN DIAMETER AND SHOULD BE CONNECTED TO GND FOR MAX THERMAL PERFORMANCE
5. GREEN RECTANGLES (SHADED AREA) indicate SOLDER STENCIL OPENING ON EXPOSED PAD AREA. SIZE SHOULD BE 0.60x0.60 MM IN SIZE, 0.20 MM SPACING.

Note: For the most current package drawings, please see the Microchip Packaging Specification located at <http://www.microchip.com/packaging>.

POD-Land Pattern drawing # QFN33-16LD-PL-1

RECOMMENDED LAND PATTERN

NOTE: 4, 5

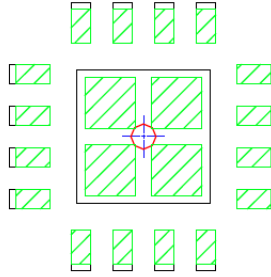

STACKED-UP

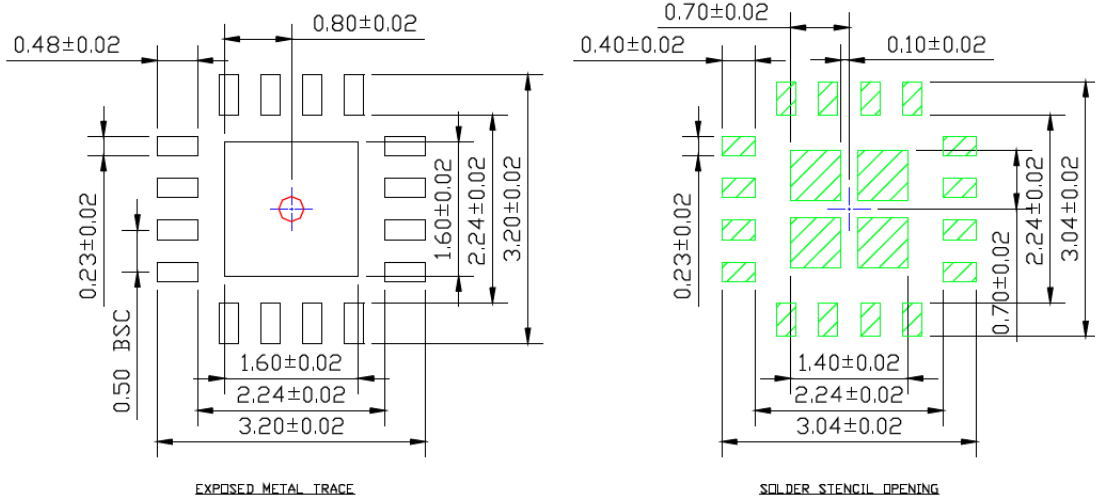

Note: For the most current package drawings, please see the Microchip Packaging Specification located at <http://www.microchip.com/packaging>.

APPENDIX A: REVISION HISTORY

Revision A (March 2022)

- Converted Micrel document SY75572L to Microchip data sheet template DS20006669A.
- Minor text changes throughout.

NOTES:

PRODUCT IDENTIFICATION SYSTEM

To order or obtain information, e.g., on pricing or delivery, contact your local Microchip representative or sales office.

PART # Device	X Supply Voltage Range	X Package	X Junction Temperature Range	XX Special Processing	Examples: a) SY75572LMG: SY75572, 3.3V Output Voltage, 16-Lead QFN, -40°C to +85°C Temperature Range, 100/Tube b) SY75572LMG-TR: SY75572, 3.3V Output Voltage, 16-Lead QFN, -40°C to +85°C Temperature Range, 1,000/Reel
Device: SY75572: 2.5V/3.3V, 2.5 GHz Differential Two-Channel Precision CML Delay Line Supply Voltage: L = 3.3V Package: M = 16-Lead QFN Temperature Range: G = -40°C to +85°C (NiPdAu Lead Free) Special Processing: <blank> = 100/Tube <T/R> = 1,000/Reel					

NOTES:

Note the following details of the code protection feature on Microchip products:

- Microchip products meet the specifications contained in their particular Microchip Data Sheet.
- Microchip believes that its family of products is secure when used in the intended manner, within operating specifications, and under normal conditions.
- Microchip values and aggressively protects its intellectual property rights. Attempts to breach the code protection features of Microchip product is strictly prohibited and may violate the Digital Millennium Copyright Act.
- Neither Microchip nor any other semiconductor manufacturer can guarantee the security of its code. Code protection does not mean that we are guaranteeing the product is “unbreakable”. Code protection is constantly evolving. Microchip is committed to continuously improving the code protection features of our products.

This publication and the information herein may be used only with Microchip products, including to design, test, and integrate Microchip products with your application. Use of this information in any other manner violates these terms. Information regarding device applications is provided only for your convenience and may be superseded by updates. It is your responsibility to ensure that your application meets with your specifications. Contact your local Microchip sales office for additional support or, obtain additional support at <https://www.microchip.com/en-us/support/design-help/client-support-services>.

THIS INFORMATION IS PROVIDED BY MICROCHIP "AS IS". MICROCHIP MAKES NO REPRESENTATIONS OR WARRANTIES OF ANY KIND WHETHER EXPRESS OR IMPLIED, WRITTEN OR ORAL, STATUTORY OR OTHERWISE, RELATED TO THE INFORMATION INCLUDING BUT NOT LIMITED TO ANY IMPLIED WARRANTIES OF NON-INFRINGEMENT, MERCHANTABILITY, AND FITNESS FOR A PARTICULAR PURPOSE, OR WARRANTIES RELATED TO ITS CONDITION, QUALITY, OR PERFORMANCE.

IN NO EVENT WILL MICROCHIP BE LIABLE FOR ANY INDIRECT, SPECIAL, PUNITIVE, INCIDENTAL, OR CONSEQUENTIAL LOSS, DAMAGE, COST, OR EXPENSE OF ANY KIND WHATSOEVER RELATED TO THE INFORMATION OR ITS USE, HOWEVER CAUSED, EVEN IF MICROCHIP HAS BEEN ADVISED OF THE POSSIBILITY OR THE DAMAGES ARE FORESEEABLE. TO THE FULLEST EXTENT ALLOWED BY LAW, MICROCHIP'S TOTAL LIABILITY ON ALL CLAIMS IN ANY WAY RELATED TO THE INFORMATION OR ITS USE WILL NOT EXCEED THE AMOUNT OF FEES, IF ANY, THAT YOU HAVE PAID DIRECTLY TO MICROCHIP FOR THE INFORMATION.

Use of Microchip devices in life support and/or safety applications is entirely at the buyer's risk, and the buyer agrees to defend, indemnify and hold harmless Microchip from any and all damages, claims, suits, or expenses resulting from such use. No licenses are conveyed, implicitly or otherwise, under any Microchip intellectual property rights unless otherwise stated.

For information regarding Microchip's Quality Management Systems, please visit www.microchip.com/quality.

Trademarks

The Microchip name and logo, the Microchip logo, Adaptec, AnyRate, AVR, AVR logo, AVR Freaks, BesTime, BitCloud, CryptoMemory, CryptoRF, dsPIC, flexPWR, HELDO, IGLOO, JukeBlox, KeeLoq, Kleer, LANCheck, LinkMD, maXStylus, maXTouch, MediaLB, megaAVR, Microsemi, Microsemi logo, MOST, MOST logo, MPLAB, OptoLyzer, PIC, picoPower, PICSTART, PIC32 logo, PolarFire, Prochip Designer, QTouch, SAM-BA, SenGenuity, SpyNIC, SST, SST Logo, SuperFlash, Symmetricom, SyncServer, Tachyon, TimeSource, tinyAVR, UNI/O, Vectron, and XMEGA are registered trademarks of Microchip Technology Incorporated in the U.S.A. and other countries.

AgileSwitch, APT, ClockWorks, The Embedded Control Solutions Company, EtherSynch, Flashtec, Hyper Speed Control, HyperLight Load, IntelliMOS, Libero, motorBench, mTouch, Powermite 3, Precision Edge, ProASIC, ProASIC Plus, ProASIC Plus logo, QuietWire, SmartFusion, SyncWorld, Temux, TimeCesium, TimeHub, TimePictra, TimeProvider, TrueTime, WinPath, and ZL are registered trademarks of Microchip Technology Incorporated in the U.S.A.

Adjacent Key Suppression, AKS, Analog-for-the-Digital Age, Any Capacitor, AnyIn, AnyOut, Augmented Switching, BlueSky, BodyCom, CodeGuard, CryptoAuthentication, CryptoAutomotive, CryptoCompanion, CryptoController, dsPICDEM, dsPICDEM.net, Dynamic Average Matching, DAM, ECAN, Espresso T1S, EtherGREEN, GridTime, IdealBridge, In-Circuit Serial Programming, ICSP, INICnet, Intelligent Paralleling, Inter-Chip Connectivity, JitterBlocker, Knob-on-Display, maxCrypto, maxView, memBrain, Mindi, MiWi, MPASM, MPF, MPLAB Certified logo, MPLIB, MPLINK, MultiTRAK, NetDetach, NVM Express, NVMe, Omniscient Code Generation, PICDEM, PICDEM.net, PICkit, PICtail, PowerSmart, PureSilicon, QMatrix, REAL ICE, Ripple Blocker, RTAX, RTG4, SAM-ICE, Serial Quad I/O, simpleMAP, SimpliPHY, SmartBuffer, SmartHLS, SMART-I.S., storClad, SQI, SuperSwitcher, SuperSwitcher II, Switchtec, SynchroPHY, Total Endurance, TSHARC, USBCheck, VariSense, VectorBlox, VeriPHY, ViewSpan, WiperLock, XpressConnect, and ZENA are trademarks of Microchip Technology Incorporated in the U.S.A. and other countries.

SQTP is a service mark of Microchip Technology Incorporated in the U.S.A.

The Adaptec logo, Frequency on Demand, Silicon Storage Technology, Symmcom, and Trusted Time are registered trademarks of Microchip Technology Inc. in other countries.

GestIC is a registered trademark of Microchip Technology Germany II GmbH & Co. KG, a subsidiary of Microchip Technology Inc., in other countries.

All other trademarks mentioned herein are property of their respective companies.

© 2022, Microchip Technology Incorporated and its subsidiaries.

All Rights Reserved.

ISBN: 978-1-6683-0161-6



MICROCHIP

Worldwide Sales and Service

AMERICAS

Corporate Office
2355 West Chandler Blvd.
Chandler, AZ 85224-6199
Tel: 480-792-7200
Fax: 480-792-7277
Technical Support:
<http://www.microchip.com/support>
Web Address:
www.microchip.com

Atlanta

Duluth, GA
Tel: 678-957-9614
Fax: 678-957-1455

Austin, TX

Tel: 512-257-3370

Boston

Westborough, MA
Tel: 774-760-0087
Fax: 774-760-0088

Chicago

Itasca, IL
Tel: 630-285-0071
Fax: 630-285-0075

Dallas

Addison, TX
Tel: 972-818-7423
Fax: 972-818-2924

Detroit

Novi, MI
Tel: 248-848-4000

Houston, TX

Tel: 281-894-5983

Indianapolis

Noblesville, IN
Tel: 317-773-8323
Fax: 317-773-5453
Tel: 317-536-2380

Los Angeles

Mission Viejo, CA
Tel: 949-462-9523
Fax: 949-462-9608
Tel: 951-273-7800

Raleigh, NC

Tel: 919-844-7510

New York, NY

Tel: 631-435-6000

San Jose, CA

Tel: 408-735-9110
Tel: 408-436-4270

Canada - Toronto

Tel: 905-695-1980
Fax: 905-695-2078

ASIA/PACIFIC

Australia - Sydney
Tel: 61-2-9868-6733

China - Beijing
Tel: 86-10-8569-7000

China - Chengdu
Tel: 86-28-8665-5511

China - Chongqing
Tel: 86-23-8980-9588

China - Dongguan
Tel: 86-769-8702-9880

China - Guangzhou
Tel: 86-20-8755-8029

China - Hangzhou
Tel: 86-571-8792-8115

China - Hong Kong SAR
Tel: 852-2943-5100

China - Nanjing
Tel: 86-25-8473-2460

China - Qingdao
Tel: 86-532-8502-7355

China - Shanghai
Tel: 86-21-3326-8000

China - Shenyang
Tel: 86-24-2334-2829

China - Shenzhen
Tel: 86-755-8864-2200

China - Suzhou
Tel: 86-186-6233-1526

China - Wuhan
Tel: 86-27-5980-5300

China - Xian
Tel: 86-29-8833-7252

China - Xiamen
Tel: 86-592-2388138

China - Zhuhai
Tel: 86-756-3210040

ASIA/PACIFIC

India - Bangalore
Tel: 91-80-3090-4444

India - New Delhi
Tel: 91-11-4160-8631

India - Pune
Tel: 91-20-4121-0141

Japan - Osaka
Tel: 81-6-6152-7160

Japan - Tokyo
Tel: 81-3-6880-3770

Korea - Daegu
Tel: 82-53-744-4301

Korea - Seoul
Tel: 82-2-554-7200

Malaysia - Kuala Lumpur
Tel: 60-3-7651-7906

Malaysia - Penang
Tel: 60-4-227-8870

Philippines - Manila
Tel: 63-2-634-9065

Singapore
Tel: 65-6334-8870

Taiwan - Hsin Chu
Tel: 886-3-577-8366

Taiwan - Kaohsiung
Tel: 886-7-213-7830

Taiwan - Taipei
Tel: 886-2-2508-8600

Thailand - Bangkok
Tel: 66-2-694-1351

Vietnam - Ho Chi Minh
Tel: 84-28-5448-2100

EUROPE

Austria - Wels
Tel: 43-7242-2244-39
Fax: 43-7242-2244-393

Denmark - Copenhagen
Tel: 45-4485-5910
Fax: 45-4485-2829

Finland - Espoo
Tel: 358-9-4520-820

France - Paris
Tel: 33-1-69-53-63-20
Fax: 33-1-69-30-90-79

Germany - Garching
Tel: 49-8931-9700

Germany - Haan
Tel: 49-2129-3766400

Germany - Heilbronn
Tel: 49-7131-72400

Germany - Karlsruhe
Tel: 49-721-625370

Germany - Munich
Tel: 49-89-627-144-0
Fax: 49-89-627-144-44

Germany - Rosenheim
Tel: 49-8031-354-560

Israel - Ra'anana
Tel: 972-9-744-7705

Italy - Milan
Tel: 39-0331-742611
Fax: 39-0331-466781

Italy - Padova
Tel: 39-049-7625286

Netherlands - Drunen
Tel: 31-416-690399
Fax: 31-416-690340

Norway - Trondheim
Tel: 47-7288-4388

Poland - Warsaw
Tel: 48-22-3325737

Romania - Bucharest
Tel: 40-21-407-87-50

Spain - Madrid
Tel: 34-91-708-08-90
Fax: 34-91-708-08-91

Sweden - Gothenberg
Tel: 46-31-704-60-40

Sweden - Stockholm
Tel: 46-8-5090-4654

UK - Wokingham
Tel: 44-118-921-5800
Fax: 44-118-921-5820