

Dual Differential PECL-to-TTL Translator

Features

- 3.0 ns Typical Propagation Delay
- <300 ps Typical Within-Device Skew
- Differential PECL Inputs
- 24 mA TTL Outputs
- Flow-Through Pinouts
- Internal Input 50 kΩ Pull-Down Resistors
- Available in 8-Lead SOIC Package

General Description

The SY100ELT23 is a dual differential PECL-to-TTL translator. Because PECL (positive ECL) levels are used, only +5V and ground are required. The small outline 8-lead SOIC package and low skew, dual gate design make the ELT23 ideal for applications that require the translation of a clock or data signal.

The ELT23 is compatible with positive ECL 100K logic levels.

Package Type

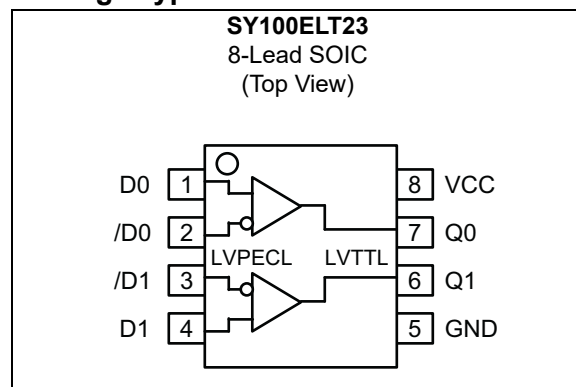

SY100ELT23

1.0 ELECTRICAL CHARACTERISTICS

Absolute Maximum Ratings †

Power Supply Voltage (V_{CC})	-0.5V to +7.0V
PECL Input Voltage (V_{IN})	0V to $V_{CC}+0.5V$
Voltage Applied to Output at High State (V_{OUT})	-0.5V to +5.5V
Current Applied to Output at Low State (I_{OUT})	Twice the Rated I_{OL} in mA

† **Notice:** Permanent device damage can occur if absolute maximum ratings are exceeded. This is a stress rating only and functional operation is not implied at conditions other than those detailed in the operational sections of this data sheet. Exposure to absolute maximum rating conditions for extended periods may affect device reliability.

TTL DC ELECTRICAL CHARACTERISTICS [Note 1](#)

Electrical Characteristics: $V_{CC} = V_{CC} (\text{Min.})$ to $V_{CC} (\text{Max.})$; Values valid from -40°C to $+85^{\circ}\text{C}$ unless otherwise noted.						
Parameter	Symbol	Min.	Typ.	Max.	Units	Conditions
Power Supply Current	I_{CC}	—	—	30	mA	—
Output High Voltage	V_{OH}	2.5	—	—	V	$I_{OH} = -3.0 \text{ mA}$
		2.0	—	—		$I_{OH} = -15 \text{ mA}$
Output Low Voltage	V_{OL}	—	—	0.5	V	$I_{OL} = 24 \text{ mA}$
Output Short Circuit Current	I_{OS}	-200	—	-80	mA	$V_{OUT} = 0V$

Note 1: Parametric values specified at 5V power supply range for ELT23 series: +4.5V to +5.5V.

PECL DC ELECTRICAL CHARACTERISTICS [Note 1](#)

Electrical Characteristics: $V_{CC} = V_{CC} (\text{Min.})$ to $V_{CC} (\text{Max.})$; Values valid from -40°C to $+85^{\circ}\text{C}$ unless otherwise noted.						
Parameter	Symbol	Min.	Typ.	Max.	Units	Conditions
Input High Current	I_{IH}	—	—	150	μA	—
Input Low Current	I_{IL}	0.5	—	—	μA	—
Common Mode Range	V_{CMR}	2.2	—	V_{CC}	V	—
Input High Voltage	V_{IH}	3835	—	4120	mV	Note 2
Input Low Voltage	V_{IL}	3190	—	3525	mV	Note 2

Note 1: Parametric values specified at 5V power supply range for ELT23 series: +4.5V to +5.5V.

2: These values are for $V_{CC} = 5.0V$. Level specifications will vary 1:1 V_{CC} .

AC ELECTRICAL CHARACTERISTICS

Electrical Characteristics: $V_{CC} = V_{CC} \text{ (Min.) to } V_{CC} \text{ (Max.)}$; Values valid from -40°C to $+85^{\circ}\text{C}$ unless otherwise noted.

Parameter	Symbol	Min.	Typ.	Max.	Units	Condition
Maximum Input Frequency	f_{MAX}	160	—	—	MHz	$C_L = 50 \text{ pF}$
Propagation Delay D to Output Q	t_{PLH}, t_{PHL}	2.5	3.0	3.5	ns	$C_L = 50 \text{ pF}$
Part-to-Part Skew	t_{SKPP}	—	—	0.5	ns	$C_L = 50 \text{ pF}$, Note 2 , Note 5
Within-Device Skew	t_{SKEW++}	—	—	0.3	ns	$C_L = 50 \text{ pF}$, Note 3 , Note 5
	t_{SKEW--}	—	—			$C_L = 50 \text{ pF}$, Note 4 , Note 5
Input Swing	V_{PP}	200	—	1000	mV	Note 6
Output Rise/Fall Time (1.0V to 2.0V)	t_r/t_f	—	—	1.5	ns	$C_L = 50 \text{ pF}$

- Note 1:** Parametric values specified at 5V power supply range for ELT23 series: +4.5V to +5.5V.
- 2:** Part-to-Part skew considering High-to-High transitions at common V_{CC} level
- 3:** Within-Device skew considering High-to-High transitions at common V_{CC} level.
- 4:** Within-Device skew considering Low-to-Low transitions at common V_{CC} level.
- 5:** All skew parameters are guaranteed, but not tested.
- 6:** Input swing for which AC parameters are guaranteed. 200 mV input guarantees full logic at output.

TEMPERATURE SPECIFICATIONS

Parameters	Symbol	Min.	Typ.	Max.	Units	Conditions
Temperature Ranges						
Ambient Operating Temperature	T_A	-40	—	+85	$^{\circ}\text{C}$	—
Storage Temperature	T_S	-65	—	+150	$^{\circ}\text{C}$	—
Lead Temperature	—	—	—	+260	$^{\circ}\text{C}$	Soldering, 20 sec.

TRUTH TABLE

D	/D	Q
L	H	L
H	L	H
Open	Open	L

SY100ELT23

2.0 PIN DESCRIPTIONS

The descriptions of the pins are listed in [Table 2-1](#).

TABLE 2-1: PIN FUNCTION TABLE

Pin Number	Pin Name	Description
1, 2	D0, /D0	Differential PECL Inputs.
4, 3	D1, /D1	Differential PECL Inputs.
5	GND	Ground.
7, 6	Q0, Q1	TTL Outputs.
8	VCC	+5.0V Supply.

3.0 PACKAGING INFORMATION

3.1 Package Marking Information

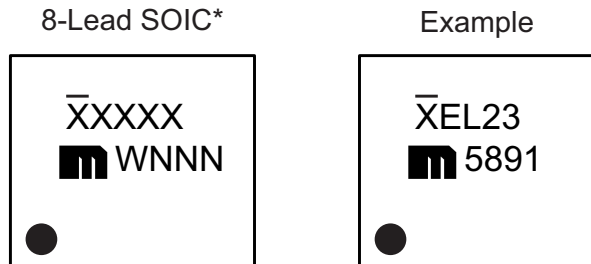

Legend:	XX...X	Product code or customer-specific information
	Y	Year code (last digit of calendar year)
	YY	Year code (last 2 digits of calendar year)
	WW	Week code (week of January 1 is week '01')
	NNN	Alphanumeric traceability code
	(e3)	Pb-free JEDEC® designator for Matte Tin (Sn)
	*	This package is Pb-free. The Pb-free JEDEC designator (e3) can be found on the outer packaging for this package.
	•, ▲, ▼	Pin one index is identified by a dot, delta up, or delta down (triangle mark).
Note:	In the event the full Microchip part number cannot be marked on one line, it will be carried over to the next line, thus limiting the number of available characters for customer-specific information. Package may or may not include the corporate logo.	
	Underbar (_) and/or Overbar (¯) symbol may not be to scale.	

SY100ELT23

TITLE

8 LEAD SOICN PACKAGE OUTLINE & RECOMMENDED LAND PATTERN

DRAWING #	SOICN-8LD-PL-1	UNIT	INCH [MM]
------------------	----------------	-------------	-----------

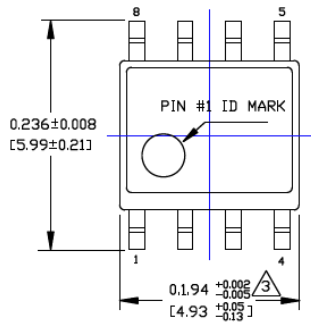

TOP VIEW

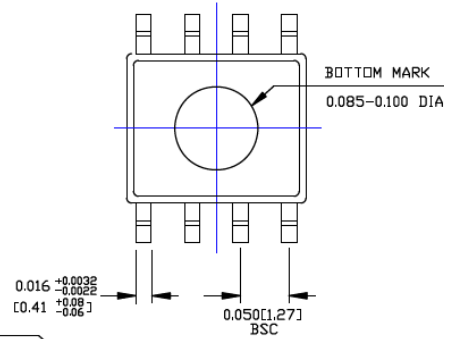

BOTTOM VIEW

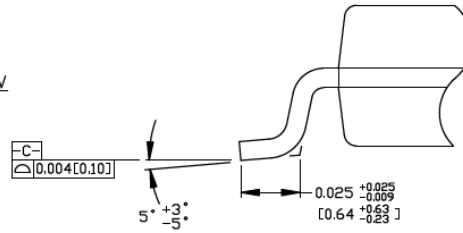

DETAIL "A"

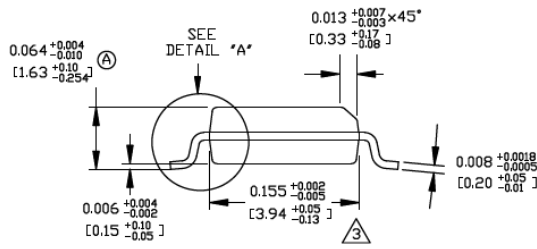

END VIEW

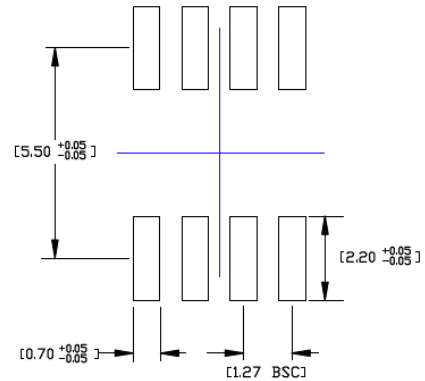

RECOMMENDED LAND PATTERN

NOTES:

1. DIMENSIONS ARE IN INCHES[MM].
2. CONTROLLING DIMENSION: INCHES.
3. DIMENSION DOES NOT INCLUDE MOLD FLASH OR PROTRUSIONS, EITHER OF WHICH SHALL NOT EXCEED 0.010[0.25] PER SIDE.

Note: For the most current package drawings, please see the Microchip Packaging Specification located at <http://www.microchip.com/packaging>.

APPENDIX A: REVISION HISTORY

Revision A (August 2019)

- Converted Micrel document SY100ELT23 to Microchip data sheet DS20006235A.
- Minor text changes throughout.
- Removal of all reference to the discontinued SY10ELT23.

Revision B (April 2022)

- Corrected the description for Pins 1 and 2 in [Table 2-1](#).

SY100ELT23

NOTES:

PRODUCT IDENTIFICATION SYSTEM

To order or obtain information, e.g., on pricing or delivery, contact your local Microchip representative or sales office.

<u>Part No.</u>	<u>X</u>	<u>X</u>	<u>-XX</u>	Examples:
Device	Package	Temp. Range	Packing	
Device:	SY100ELT23: Dual Differential PECL-to-TTL Translator			a) SY100ELT23ZG: SY100ELT23,8 -Lead SOIC, -40°C to +85°C Temperature Range, 95/Tube b) SY100ELT23ZG-TR: SY100ELT23, 8-Lead SOIC, -40°C to +85°C Temperature Range, 1,000/Reel Note 1: Tape and Reel identifier only appears in the catalog part number description. This identifier is used for ordering purposes and is not printed on the device package. Check with your Microchip Sales Office for package availability with the Tape and Reel option.
Package:	Z	=	8-Lead SOIC	
Temperature Range:	G	=	-40°C to +85°C (NiPdAu Lead-Free)	
Tape and Reel:	<blank>	=	95/Tube TR = 1,000/Reel	

SY100ELT23

NOTES:

Note the following details of the code protection feature on Microchip products:

- Microchip products meet the specifications contained in their particular Microchip Data Sheet.
- Microchip believes that its family of products is secure when used in the intended manner, within operating specifications, and under normal conditions.
- Microchip values and aggressively protects its intellectual property rights. Attempts to breach the code protection features of Microchip product is strictly prohibited and may violate the Digital Millennium Copyright Act.
- Neither Microchip nor any other semiconductor manufacturer can guarantee the security of its code. Code protection does not mean that we are guaranteeing the product is “unbreakable”. Code protection is constantly evolving. Microchip is committed to continuously improving the code protection features of our products.

This publication and the information herein may be used only with Microchip products, including to design, test, and integrate Microchip products with your application. Use of this information in any other manner violates these terms. Information regarding device applications is provided only for your convenience and may be superseded by updates. It is your responsibility to ensure that your application meets with your specifications. Contact your local Microchip sales office for additional support or, obtain additional support at <https://www.microchip.com/en-us/support/design-help/client-support-services>.

THIS INFORMATION IS PROVIDED BY MICROCHIP "AS IS". MICROCHIP MAKES NO REPRESENTATIONS OR WARRANTIES OF ANY KIND WHETHER EXPRESS OR IMPLIED, WRITTEN OR ORAL, STATUTORY OR OTHERWISE, RELATED TO THE INFORMATION INCLUDING BUT NOT LIMITED TO ANY IMPLIED WARRANTIES OF NON-INFRINGEMENT, MERCHANTABILITY, AND FITNESS FOR A PARTICULAR PURPOSE, OR WARRANTIES RELATED TO ITS CONDITION, QUALITY, OR PERFORMANCE.

IN NO EVENT WILL MICROCHIP BE LIABLE FOR ANY INDIRECT, SPECIAL, PUNITIVE, INCIDENTAL, OR CONSEQUENTIAL LOSS, DAMAGE, COST, OR EXPENSE OF ANY KIND WHATSOEVER RELATED TO THE INFORMATION OR ITS USE, HOWEVER CAUSED, EVEN IF MICROCHIP HAS BEEN ADVISED OF THE POSSIBILITY OR THE DAMAGES ARE FORESEEABLE. TO THE FULLEST EXTENT ALLOWED BY LAW, MICROCHIP'S TOTAL LIABILITY ON ALL CLAIMS IN ANY WAY RELATED TO THE INFORMATION OR ITS USE WILL NOT EXCEED THE AMOUNT OF FEES, IF ANY, THAT YOU HAVE PAID DIRECTLY TO MICROCHIP FOR THE INFORMATION.

Use of Microchip devices in life support and/or safety applications is entirely at the buyer's risk, and the buyer agrees to defend, indemnify and hold harmless Microchip from any and all damages, claims, suits, or expenses resulting from such use. No licenses are conveyed, implicitly or otherwise, under any Microchip intellectual property rights unless otherwise stated.

For information regarding Microchip's Quality Management Systems, please visit www.microchip.com/quality.

Trademarks

The Microchip name and logo, the Microchip logo, Adaptec, AnyRate, AVR, AVR logo, AVR Freaks, BesTime, BitCloud, CryptoMemory, CryptoRF, dsPIC, flexPWR, HELDO, IGLOO, JukeBlox, KeeLoq, Kleer, LANCheck, LinkMD, maXStylus, maXTouch, MediaLB, megaAVR, Microsemi, Microsemi logo, MOST, MOST logo, MPLAB, OptoLyzer, PIC, picoPower, PICSTART, PIC32 logo, PolarFire, Prochip Designer, QTouch, SAM-BA, SenGenuity, SpyNIC, SST, SST Logo, SuperFlash, Symmetricom, SyncServer, Tachyon, TimeSource, tinyAVR, UNI/O, Vectron, and XMEGA are registered trademarks of Microchip Technology Incorporated in the U.S.A. and other countries.

AgileSwitch, APT, ClockWorks, The Embedded Control Solutions Company, EtherSynch, Flashtec, Hyper Speed Control, HyperLight Load, IntelliMOS, Libero, motorBench, mTouch, Powermite 3, Precision Edge, ProASIC, ProASIC Plus, ProASIC Plus logo, QuietWire, SmartFusion, SyncWorld, Temux, TimeCesium, TimeHub, TimePictra, TimeProvider, TrueTime, WinPath, and ZL are registered trademarks of Microchip Technology Incorporated in the U.S.A.

Adjacent Key Suppression, AKS, Analog-for-the-Digital Age, Any Capacitor, AnyIn, AnyOut, Augmented Switching, BlueSky, BodyCom, CodeGuard, CryptoAuthentication, CryptoAutomotive, CryptoCompanion, CryptoController, dsPICDEM, dsPICDEM.net, Dynamic Average Matching, DAM, ECAN, Espresso T1S, EtherGREEN, GridTime, IdealBridge, In-Circuit Serial Programming, ICSP, INICnet, Intelligent Paralleling, Inter-Chip Connectivity, JitterBlocker, Knob-on-Display, maxCrypto, maxView, memBrain, Mindi, MiWi, MPASM, MPF, MPLAB Certified logo, MPLIB, MPLINK, MultiTRAK, NetDetach, NVM Express, NVMe, Omniscient Code Generation, PICDEM, PICDEM.net, PICkit, PICtail, PowerSmart, PureSilicon, QMatrix, REAL ICE, Ripple Blocker, RTAX, RTG4, SAM-ICE, Serial Quad I/O, simpleMAP, SimpliPHY, SmartBuffer, SmartHLS, SMART-I.S., storClad, SQL, SuperSwitcher, SuperSwitcher II, Switchtec, SynchroPHY, Total Endurance, TSHARC, USBCheck, VariSense, VectorBlox, VeriPHY, ViewSpan, WiperLock, XpressConnect, and ZENA are trademarks of Microchip Technology Incorporated in the U.S.A. and other countries.

SQTP is a service mark of Microchip Technology Incorporated in the U.S.A.

The Adaptec logo, Frequency on Demand, Silicon Storage Technology, Symmcom, and Trusted Time are registered trademarks of Microchip Technology Inc. in other countries.

GestIC is a registered trademark of Microchip Technology Germany II GmbH & Co. KG, a subsidiary of Microchip Technology Inc., in other countries.

All other trademarks mentioned herein are property of their respective companies.

© 2019 - 2022, Microchip Technology Incorporated and its subsidiaries.

All Rights Reserved.

ISBN: 978-1-6683-0263-7



MICROCHIP

Worldwide Sales and Service

AMERICAS

Corporate Office
2355 West Chandler Blvd.
Chandler, AZ 85224-6199
Tel: 480-792-7200
Fax: 480-792-7277
Technical Support:
<http://www.microchip.com/support>
Web Address:
www.microchip.com

Atlanta

Duluth, GA
Tel: 678-957-9614
Fax: 678-957-1455

Austin, TX

Tel: 512-257-3370

Boston

Westborough, MA
Tel: 774-760-0087
Fax: 774-760-0088

Chicago

Itasca, IL
Tel: 630-285-0071
Fax: 630-285-0075

Dallas

Addison, TX
Tel: 972-818-7423
Fax: 972-818-2924

Detroit

Novi, MI
Tel: 248-848-4000

Houston, TX

Tel: 281-894-5983

Indianapolis

Noblesville, IN
Tel: 317-773-8323
Fax: 317-773-5453
Tel: 317-536-2380

Los Angeles

Mission Viejo, CA
Tel: 949-462-9523
Fax: 949-462-9608
Tel: 951-273-7800

Raleigh, NC

Tel: 919-844-7510

New York, NY

Tel: 631-435-6000

San Jose, CA

Tel: 408-735-9110
Tel: 408-436-4270

Canada - Toronto

Tel: 905-695-1980
Fax: 905-695-2078

ASIA/PACIFIC

Australia - Sydney
Tel: 61-2-9868-6733

China - Beijing
Tel: 86-10-8569-7000

China - Chengdu
Tel: 86-28-8665-5511

China - Chongqing
Tel: 86-23-8980-9588

China - Dongguan
Tel: 86-769-8702-9880

China - Guangzhou
Tel: 86-20-8755-8029

China - Hangzhou
Tel: 86-571-8792-8115

China - Hong Kong SAR
Tel: 852-2943-5100

China - Nanjing
Tel: 86-25-8473-2460

China - Qingdao
Tel: 86-532-8502-7355

China - Shanghai
Tel: 86-21-3326-8000

China - Shenyang
Tel: 86-24-2334-2829

China - Shenzhen
Tel: 86-755-8864-2200

China - Suzhou
Tel: 86-186-6233-1526

China - Wuhan
Tel: 86-27-5980-5300

China - Xian
Tel: 86-29-8833-7252

China - Xiamen
Tel: 86-592-2388138

China - Zhuhai
Tel: 86-756-3210040

ASIA/PACIFIC

India - Bangalore
Tel: 91-80-3090-4444

India - New Delhi
Tel: 91-11-4160-8631

India - Pune
Tel: 91-20-4121-0141

Japan - Osaka
Tel: 81-6-6152-7160

Japan - Tokyo
Tel: 81-3-6880-3770

Korea - Daegu
Tel: 82-53-744-4301

Korea - Seoul
Tel: 82-2-554-7200

Malaysia - Kuala Lumpur
Tel: 60-3-7651-7906

Malaysia - Penang
Tel: 60-4-227-8870

Philippines - Manila
Tel: 63-2-634-9065

Singapore
Tel: 65-6334-8870

Taiwan - Hsin Chu
Tel: 886-3-577-8366

Taiwan - Kaohsiung
Tel: 886-7-213-7830

Taiwan - Taipei
Tel: 886-2-2508-8600

Thailand - Bangkok
Tel: 66-2-694-1351

Vietnam - Ho Chi Minh
Tel: 84-28-5448-2100

EUROPE

Austria - Wels
Tel: 43-7242-2244-39
Fax: 43-7242-2244-393

Denmark - Copenhagen
Tel: 45-4485-5910
Fax: 45-4485-2829

Finland - Espoo
Tel: 358-9-4520-820

France - Paris
Tel: 33-1-69-53-63-20
Fax: 33-1-69-30-90-79

Germany - Garching
Tel: 49-8931-9700

Germany - Haan
Tel: 49-2129-3766400

Germany - Heilbronn
Tel: 49-7131-72400

Germany - Karlsruhe
Tel: 49-721-625370

Germany - Munich
Tel: 49-89-627-144-0
Fax: 49-89-627-144-44

Germany - Rosenheim
Tel: 49-8031-354-560

Israel - Ra'anana
Tel: 972-9-744-7705

Italy - Milan
Tel: 39-0331-742611
Fax: 39-0331-466781

Italy - Padova
Tel: 39-049-7625286

Netherlands - Drunen
Tel: 31-416-690399
Fax: 31-416-690340

Norway - Trondheim
Tel: 47-7288-4388

Poland - Warsaw
Tel: 48-22-3325737

Romania - Bucharest
Tel: 40-21-407-87-50

Spain - Madrid
Tel: 34-91-708-08-90
Fax: 34-91-708-08-91

Sweden - Gothenberg
Tel: 46-31-704-60-40

Sweden - Stockholm
Tel: 46-8-5090-4654

UK - Wokingham
Tel: 44-118-921-5800
Fax: 44-118-921-5820