



# STV270N4F3

N-channel 40 V, 1.25 mΩ, 270 A, PowerSO-10  
STripFET™ Power MOSFET

## Features

Type	V <sub>DSS</sub>	R <sub>DS(on) max</sub>	I <sub>D</sub> <sup>(1)</sup>
STV270N4F3	40 V	< 1.5 mΩ	270 A

1. Current limited by package

- Conduction losses reduced
- Low profile, very low parasitic inductance

## Applications

- Switching application

## Description

This n-channel enhancement mode Power MOSFET is the latest refinement of STMicroelectronics' unique "single feature size" strip-based process, which has decreased the critical alignment steps, offering remarkable manufacturing reproducibility. The outcome is a transistor with extremely high packing density for low on resistance, rugged avalanche characteristics and low gate charge.

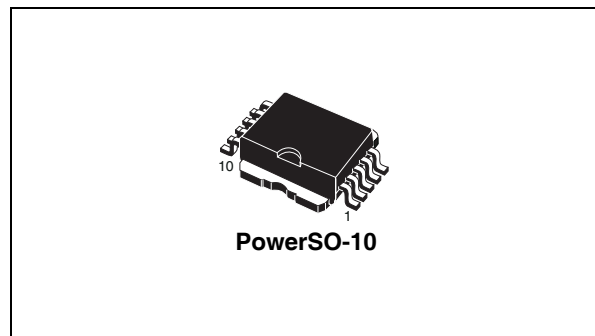

Figure 1. Internal schematic diagram and connection diagram (top view)

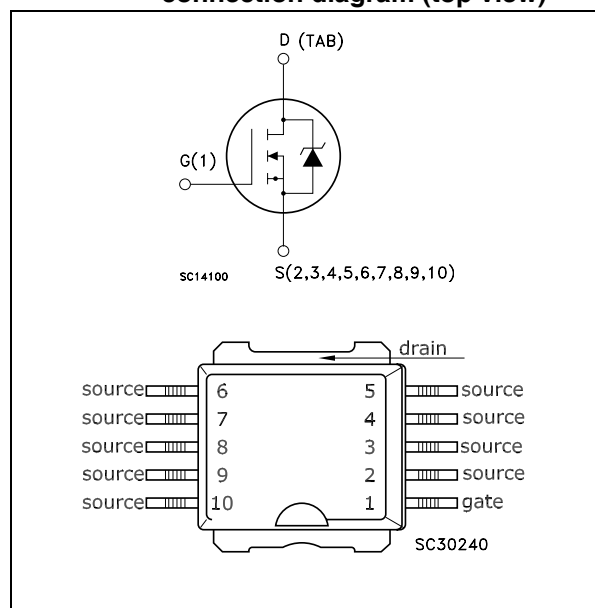

Table 1. Device summary

Order code	Marking	Package	Packaging
STV270N4F3	270N4F3	PowerSO-10	Tape and reel

# Contents

<b>1</b>	<b>Electrical ratings</b> .....	<b>3</b>
<b>2</b>	<b>Electrical characteristics</b> .....	<b>4</b>
	2.1 Electrical characteristics .....	6
<b>3</b>	<b>Test circuits</b> .....	<b>8</b>
<b>4</b>	<b>Package mechanical data</b> .....	<b>9</b>
<b>5</b>	<b>Revision history</b> .....	<b>11</b>

# 1 Electrical ratings

**Table 2. Absolute maximum ratings**

Symbol	Parameter	Value	Unit
$V_{DS}$	Drain-source voltage ( $v_{gs} = 0$ )	40	V
$V_{GS}$	Gate-source voltage	$\pm 20$	V
$I_D^{(1)}$	Drain current (continuous) at $T_C = 25\text{ }^\circ\text{C}$	270	A
$I_D$	Drain current (continuous) at $T_C = 100\text{ }^\circ\text{C}$	220	A
$I_{DM}^{(1)}$	Drain current (pulsed)	1080	A
$P_{TOT}^{(2)}$	Total dissipation at $T_C = 25\text{ }^\circ\text{C}$	300	W
	Derating factor	2	W/ $^\circ\text{C}$
$E_{AS}^{(3)}$	Single pulse avalanche energy	1000	mJ
$T_{stg}$	Storage temperature	-55 to 175	$^\circ\text{C}$
$T_j$	Operating junction temperature		

1. Current limited by package
2. This value is rated according to  $R_{thj-c}$
3. Starting  $T_j = 25\text{ }^\circ\text{C}$ ,  $I_D = 80\text{ A}$ ,  $V_{DD} = 32\text{ V}$

**Table 3. Thermal data**

Symbol	Parameter	Value	Unit
$R_{thj-case}$	Thermal resistance junction-case max	0.5	$^\circ\text{C}/\text{W}$
$R_{thj-pcb}^{(1)}$	Thermal resistance junction-pcb max	50	$^\circ\text{C}/\text{W}$

1. When mounted on 1 inch<sup>2</sup> FR-4 2 oz Cu.

## 2 Electrical characteristics

(T<sub>case</sub> = 25°C unless otherwise specified)

**Table 4. On /off states**

Symbol	Parameter	Test conditions	Min.	Typ.	Max.	Unit
V <sub>(BR)DSS</sub>	Drain-source breakdown voltage	I <sub>D</sub> = 250 μA, V <sub>GS</sub> = 0	40			V
I <sub>DSS</sub>	Zero gate voltage drain current (V <sub>GS</sub> = 0)	V <sub>DS</sub> = Max rating, V <sub>DS</sub> = Max rating, T <sub>c</sub> = 125 °C			10 100	μA μA
I <sub>GSS</sub>	Gate body leakage current (V <sub>DS</sub> = 0)	V <sub>DS</sub> = ± 20 V			±200	nA
V <sub>GS(th)</sub>	Gate threshold voltage	V <sub>DS</sub> = V <sub>GS</sub> , I <sub>D</sub> = 250 μA	2		4	V
R <sub>DS(on)</sub>	Static drain-source on resistance	V <sub>GS</sub> = 10 V, I <sub>D</sub> = 80 A		1.25	1.5	mΩ

**Table 5. Dynamic**

Symbol	Parameter	Test conditions	Min.	Typ.	Max.	Unit
g <sub>fs</sub> (1)	Forward transconductance	V <sub>DS</sub> = 10 V, I <sub>D</sub> = 100 A		200		S
C <sub>iss</sub>	Input capacitance	V <sub>DS</sub> = 25 V, f = 1 MHz, V <sub>GS</sub> = 0		7500		pF
C <sub>oss</sub>	Output capacitance			1900		pF
C <sub>rss</sub>	Reverse transfer capacitance			50		pF
Q <sub>g</sub>	Total gate charge	V <sub>DD</sub> = 20 V, I <sub>D</sub> = 160 A,		110	150	nC
Q <sub>gs</sub>	Gate-source charge	V <sub>GS</sub> = 10 V		30		nC
Q <sub>gd</sub>	Gate-drain charge	(see Figure 14)		25		nC

1. Pulsed: Pulse duration = 300 μs, duty cycle 1.5%

**Table 6. Switching times**

Symbol	Parameter	Test conditions	Min.	Typ.	Max	Unit
$t_{d(on)}$ $t_r$	Turn-on delay time Rise time	$V_{DD} = 20\text{ V}$ , $I_D = 80\text{ A}$ $R_G = 4.7\ \Omega$ , $V_{GS} = 10\text{ V}$ (see Figure 13)		25 180		ns ns
$t_{d(off)}$ $t_f$	Turn-off delay time Fall time	$V_{DD} = 20\text{ V}$ , $I_D = 80\text{ A}$ $R_G = 4.7\ \Omega$ , $V_{GS} = 10\text{ V}$ , (see Figure 13)		110 45		ns ns

**Table 7. Source drain diode**

Symbol	Parameter	Test conditions	Min.	Typ.	Max.	Unit
$I_{SD}$ $I_{SD}^{(1)}$	Source-drain current Source-drain current (pulsed)				270 1080	A A
$V_{SD}^{(2)}$	Forward on voltage	$I_{SD} = 80\text{ A}$ , $V_{GS} = 0$			1.3	V
$t_{rr}$ $Q_{rr}$ $I_{RRM}$	Reverse recovery time Reverse recovery charge Reverse recovery current	$I_{SD} = 160\text{ A}$ , $di/dt = 100\text{ A}/\mu\text{s}$ $V_{DD} = 32\text{ V}$ , $T_j = 150\text{ }^\circ\text{C}$ (see Figure 15)		70 225 3.2		ns nC A

1. Pulse width limited by safe operating area
2. Pulsed: Pulse duration = 300  $\mu\text{s}$ , duty cycle 1.5%

## 2.1 Electrical characteristics

Figure 2. Safe operating area

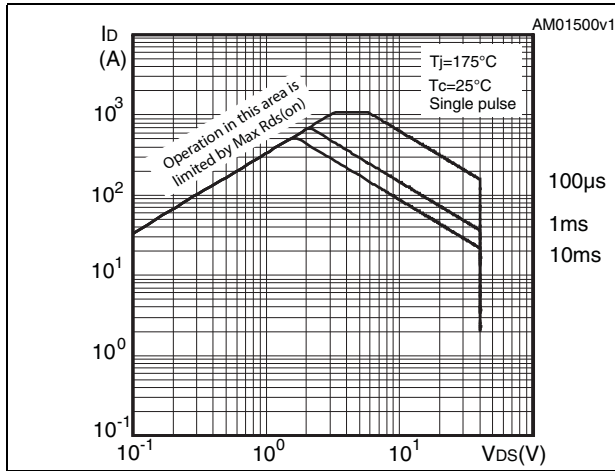

Figure 3. Thermal impedance

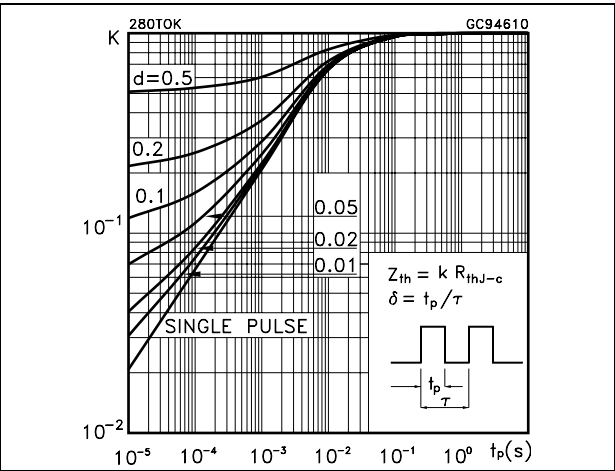

Figure 4. Output characteristics

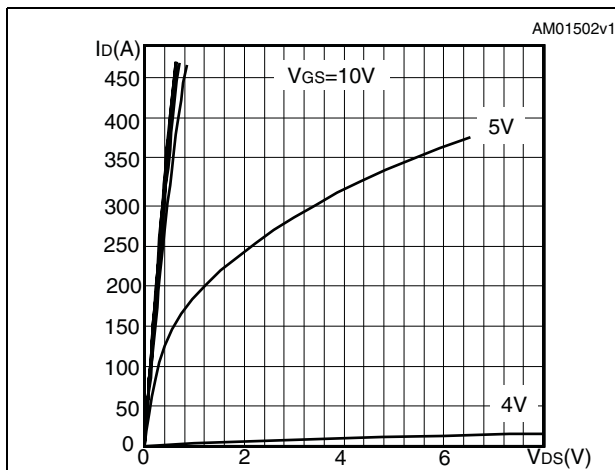

Figure 5. Transfer characteristics

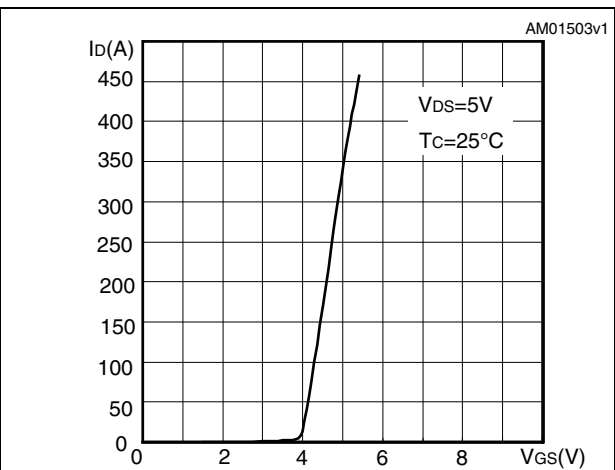

Figure 6. Static drain-source on resistance

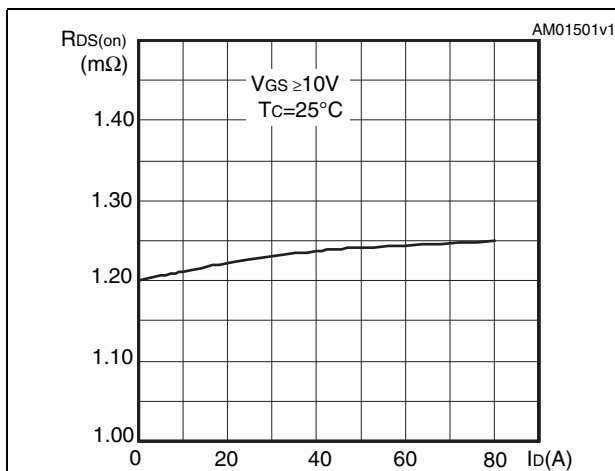

Figure 7. Normalized BVDS vs temperature

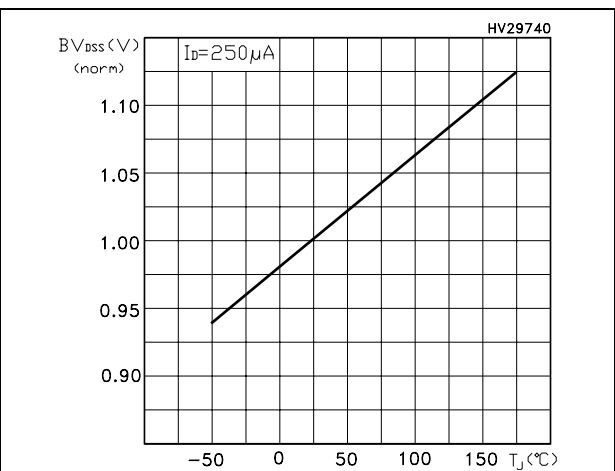

Figure 8. Gate charge vs gate-source voltage Figure 9. Capacitance variations

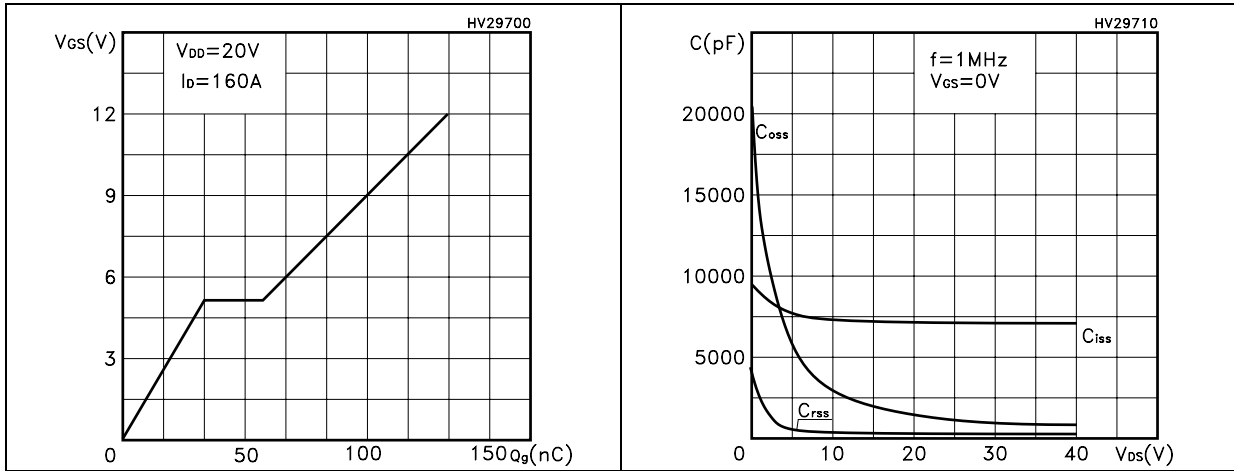

Figure 10. Normalized gate threshold voltage vs temperature Figure 11. Normalized on resistance vs temperature

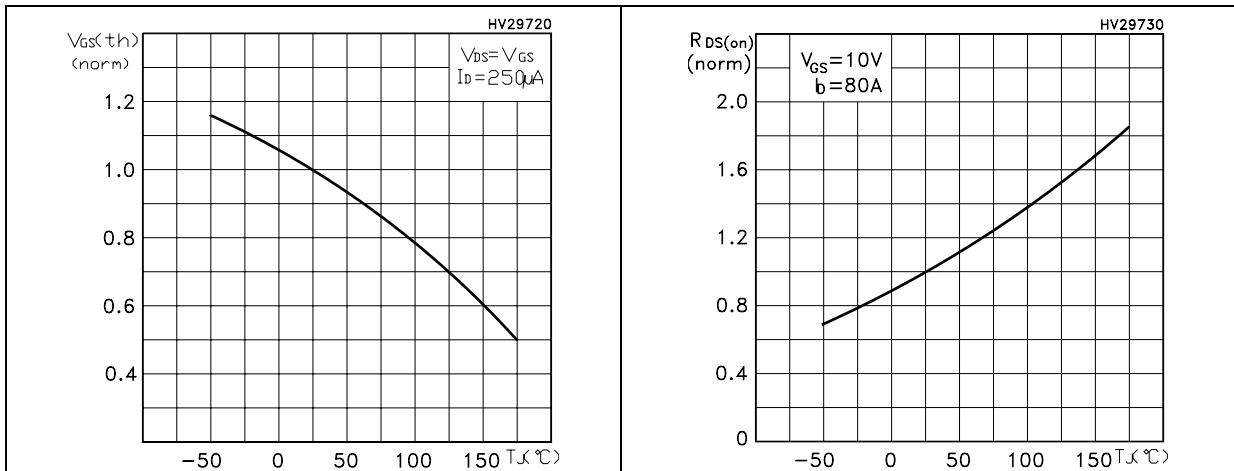
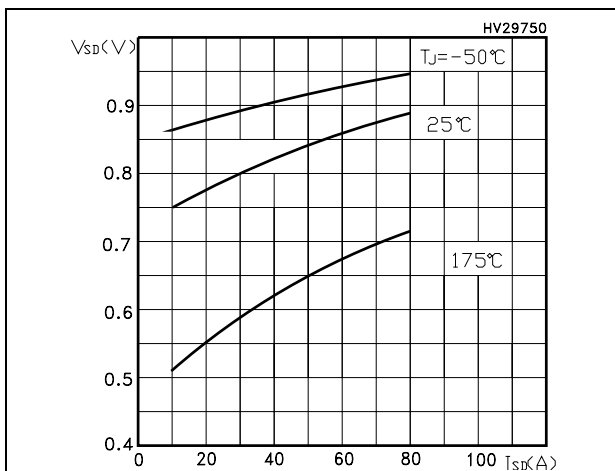

Figure 12. Source-drain diode forward characteristics



### 3 Test circuits

**Figure 13. Switching times test circuit for resistive load**



AM01468v1

**Figure 14. Gate charge test circuit**

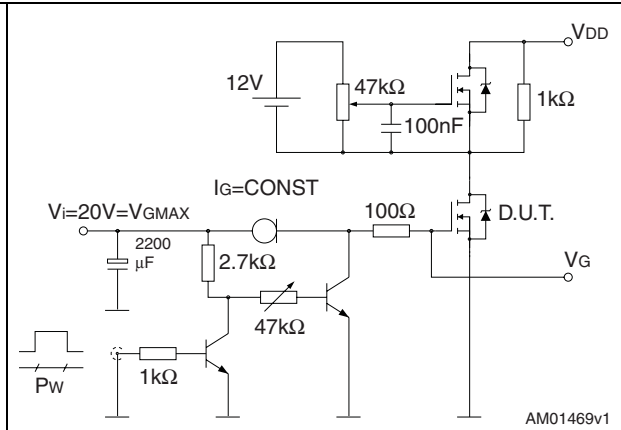

AM01469v1

**Figure 15. Test circuit for inductive load switching and diode recovery times**

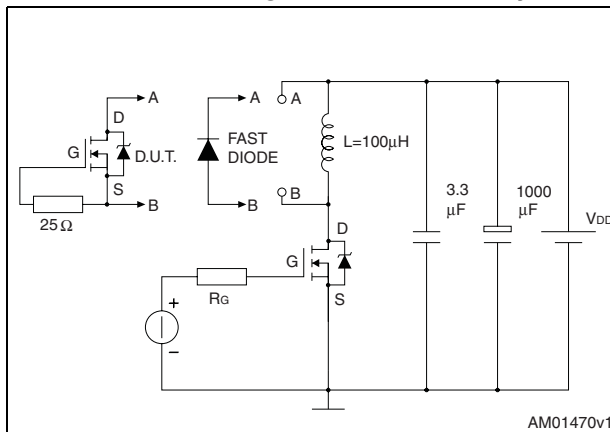

AM01470v1

**Figure 16. Unclamped inductive load test circuit**

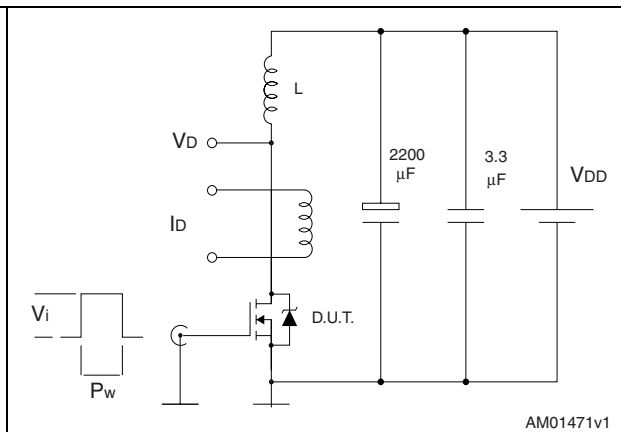

AM01471v1

**Figure 17. Unclamped inductive waveform**

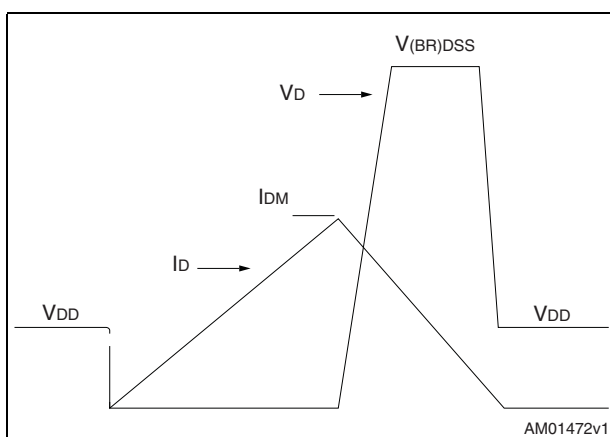

AM01472v1

**Figure 18. Switching time waveform**

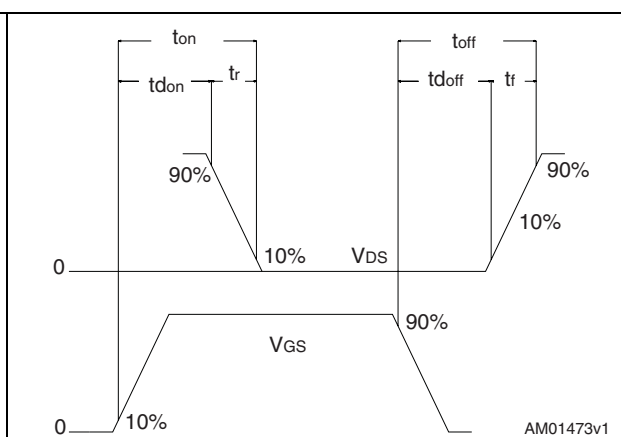

AM01473v1



## 4 Package mechanical data

In order to meet environmental requirements, ST offers these devices in ECOPACK® packages. These packages have a Lead-free second level interconnect. The category of second level interconnect is marked on the package and on the inner box label, in compliance with JEDEC Standard JESD97. The maximum ratings related to soldering conditions are also marked on the inner box label. ECOPACK is an ST trademark. ECOPACK specifications are available at: [www.st.com](http://www.st.com)

**PowerSO-10 MECHANICAL DATA**

DIM.	mm			inch		
	MIN.	TYP.	MAX.	MIN.	TYP.	MAX.
A	3.35		3.65	0.132		0.144
A1	0.00		0.10	0.000		0.004
B	0.40		0.60	0.016		0.024
C	0.35		0.55	0.013		0.022
D	9.40		9.60	0.370		0.378
D1	7.40		7.60	0.291		0.300
e		1.27			0.050	
E	9.30		9.50	0.366		0.374
E1	7.20		7.40	0.283		0.291
E2	7.20		7.60	0.283		0.300
E3	6.10		6.35	0.240		0.250
E4	5.90		6.10	0.232		0.240
F	1.25		1.35	0.049		0.053
h		0.50			0.002	
H	13.80		14.40	0.543		0.567
L	1.20		1.80	0.047		0.071
q		1.70			0.067	
$\alpha$	0°		8°			

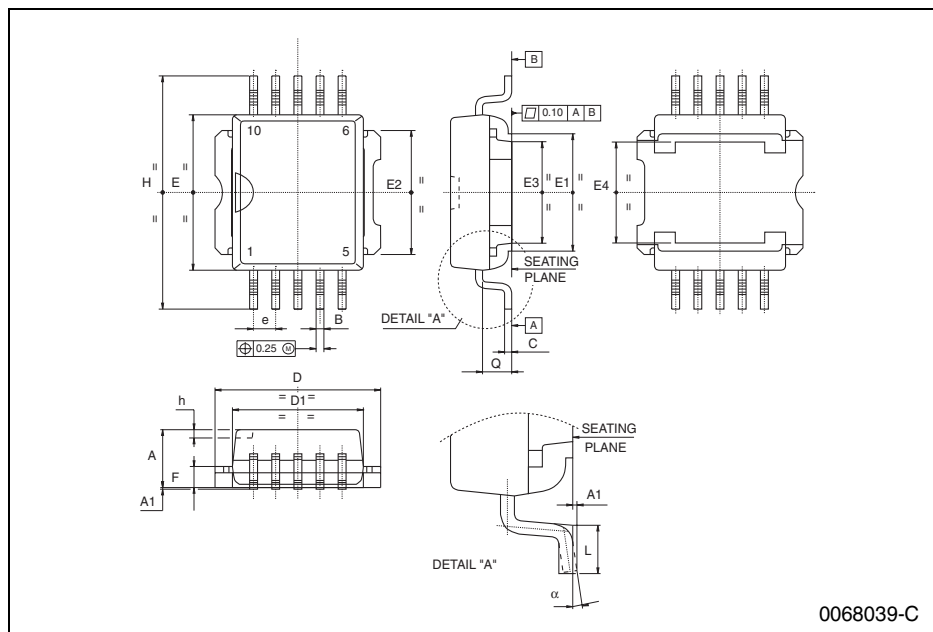

## 5 Revision history

**Table 8. Document revision history**

Date	Revision	Changes
25-Oct-2007	1	initial release
03-Apr-2008	2	I <sub>D</sub> value has been updated.
01-Oct-2008	3	Document status promoted from preliminary data to datasheet

**Please Read Carefully:**

Information in this document is provided solely in connection with ST products. STMicroelectronics NV and its subsidiaries ("ST") reserve the right to make changes, corrections, modifications or improvements, to this document, and the products and services described herein at any time, without notice.

All ST products are sold pursuant to ST's terms and conditions of sale.

Purchasers are solely responsible for the choice, selection and use of the ST products and services described herein, and ST assumes no liability whatsoever relating to the choice, selection or use of the ST products and services described herein.

No license, express or implied, by estoppel or otherwise, to any intellectual property rights is granted under this document. If any part of this document refers to any third party products or services it shall not be deemed a license grant by ST for the use of such third party products or services, or any intellectual property contained therein or considered as a warranty covering the use in any manner whatsoever of such third party products or services or any intellectual property contained therein.

**UNLESS OTHERWISE SET FORTH IN ST'S TERMS AND CONDITIONS OF SALE ST DISCLAIMS ANY EXPRESS OR IMPLIED WARRANTY WITH RESPECT TO THE USE AND/OR SALE OF ST PRODUCTS INCLUDING WITHOUT LIMITATION IMPLIED WARRANTIES OF MERCHANTABILITY, FITNESS FOR A PARTICULAR PURPOSE (AND THEIR EQUIVALENTS UNDER THE LAWS OF ANY JURISDICTION), OR INFRINGEMENT OF ANY PATENT, COPYRIGHT OR OTHER INTELLECTUAL PROPERTY RIGHT.**

**UNLESS EXPRESSLY APPROVED IN WRITING BY AN AUTHORIZED ST REPRESENTATIVE, ST PRODUCTS ARE NOT RECOMMENDED, AUTHORIZED OR WARRANTED FOR USE IN MILITARY, AIR CRAFT, SPACE, LIFE SAVING, OR LIFE SUSTAINING APPLICATIONS, NOR IN PRODUCTS OR SYSTEMS WHERE FAILURE OR MALFUNCTION MAY RESULT IN PERSONAL INJURY, DEATH, OR SEVERE PROPERTY OR ENVIRONMENTAL DAMAGE. ST PRODUCTS WHICH ARE NOT SPECIFIED AS "AUTOMOTIVE GRADE" MAY ONLY BE USED IN AUTOMOTIVE APPLICATIONS AT USER'S OWN RISK.**

Resale of ST products with provisions different from the statements and/or technical features set forth in this document shall immediately void any warranty granted by ST for the ST product or service described herein and shall not create or extend in any manner whatsoever, any liability of ST.

ST and the ST logo are trademarks or registered trademarks of ST in various countries.

Information in this document supersedes and replaces all information previously supplied.

The ST logo is a registered trademark of STMicroelectronics. All other names are the property of their respective owners.

© 2008 STMicroelectronics - All rights reserved

STMicroelectronics group of companies

Australia - Belgium - Brazil - Canada - China - Czech Republic - Finland - France - Germany - Hong Kong - India - Israel - Italy - Japan - Malaysia - Malta - Morocco - Singapore - Spain - Sweden - Switzerland - United Kingdom - United States of America

[www.st.com](http://www.st.com)