



## STTS2002

### 2.3 V memory module temperature sensor with a 2 Kb SPD EEPROM

#### Features

- 2.3 V memory module temperature sensor with integrated 2 Kb SPD EEPROM
- Forward compatible with JEDEC TSE 2002a2 and backward compatible with STTS424E02
- Operating temperature range:
  - -40 °C to +125 °C
- Single supply voltage: 2.3 V to 3.6 V
- 2 mm x 3 mm TDFN8, height: 0.80 mm (max)
  - JEDEC MO-229, WCED-3 compliant
- RoHS compliant, halogen-free

#### Temperature sensor

- Temperature sensor resolution: programmable (9-12 bits)  
0.25 °C (typ)/LSB - (10-bit) default
- Temperature sensor accuracy (max):
  - ± 1 °C from +75 °C to +95 °C
  - ± 2 °C from +40 °C to +125 °C
  - ± 3 °C from -40 °C to +125 °C
- ADC conversion time: 125 ms (max) at default resolution (10-bit)
- Typical operating supply current: 160 µA (EEPROM standby)
- Temperature hysteresis selectable set points from: 0, 1.5, 3, 6.0 °C
- Supports SMBus timeout 25 ms - 35 ms

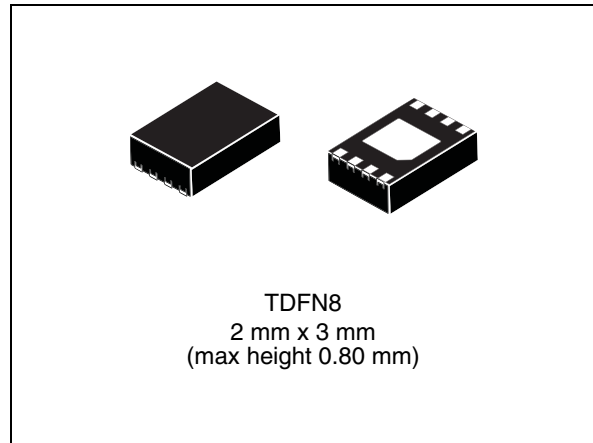

#### 2 Kb SPD EEPROM

- Functionality identical to ST's M34E02 SPD EEPROM
- Permanent and reversible software data protection for the lower 128 bytes
- Byte and page write (up to 16 bytes)
- Self-time WRITE cycle (5 ms, max)
- Automatic address incrementing

#### Two-wire bus

- Two-wire SMBus/I<sup>2</sup>C - compatible serial interface
- Supports up to 400 kHz transfer rate
- Does not initiate clock stretching

# Contents

<b>1</b>	<b>Description</b>	<b>6</b>
<b>2</b>	<b>Serial communications</b>	<b>7</b>
2.1	Device type identifier (DTI) code	7
2.2	Pin descriptions	10
2.2.1	A0, A1, A2	10
2.2.2	V <sub>SS</sub> (ground)	10
2.2.3	SDA (open drain)	10
2.2.4	SCL	10
2.2.5	$\overline{\text{EVENT}}$ (open drain)	10
2.2.6	V <sub>DD</sub> (power)	10
<b>3</b>	<b>Temperature sensor operation</b>	<b>11</b>
3.1	SMBus/I <sup>2</sup> C communications	11
3.2	SMBus/I <sup>2</sup> C slave sub-address decoding	13
3.3	SMBus/I <sup>2</sup> C AC timing consideration	14
<b>4</b>	<b>Temperature sensor registers</b>	<b>16</b>
4.1	Capability register (read-only)	17
4.2	Configuration register (read/write)	19
4.2.1	Event thresholds	19
4.2.2	Interrupt mode	19
4.2.3	Comparator mode	19
4.2.4	Shutdown mode	19
4.2.5	Event output pin functionality	22
4.3	Temperature register (read-only)	24
4.3.1	Temperature format	24
4.4	Temperature trip point registers (read/write)	25
4.4.1	Alarm window trip	26
4.4.2	Critical trip	26
4.5	Manufacturer ID register (read-only)	28
4.6	Device ID and device revision ID register (read-only)	28
4.7	Temperature resolution register (read/write)	29

---

4.8	SMBus timeout .....	29
<b>5</b>	<b>SPD EEPROM operation .....</b>	<b>30</b>
5.1	2 Kb SPD EEPROM operation .....	30
5.2	Internal device reset - SPD EEPROM .....	30
5.3	Memory addressing .....	31
5.4	Software write protect .....	32
5.4.1	SWP and CWP .....	33
5.4.2	PSWP .....	33
5.5	Write operations .....	34
5.5.1	Byte write .....	34
5.5.2	Page write .....	34
5.5.3	Write cycle polling using ACK .....	35
5.6	Read operations - SPD .....	36
5.6.1	Random address read - SPD .....	36
5.6.2	Current address read - SPD .....	37
5.6.3	Sequential read - SPD .....	37
5.6.4	Acknowledge in read mode .....	37
5.7	Initial delivery state - SPD .....	38
<b>6</b>	<b>Use in a memory module .....</b>	<b>39</b>
6.1	Programming the SPD .....	39
6.1.1	DIMM isolated .....	39
6.1.2	DIMM inserted in the application motherboard .....	39
<b>7</b>	<b>Maximum ratings .....</b>	<b>40</b>
<b>8</b>	<b>DC and AC parameters .....</b>	<b>41</b>
<b>9</b>	<b>Package mechanical data .....</b>	<b>43</b>
<b>10</b>	<b>Part numbering .....</b>	<b>50</b>
<b>11</b>	<b>Revision history .....</b>	<b>51</b>

## List of tables

Table 1.	Signal names	8
Table 2.	AC characteristics of STTS2002 for SMBus and I <sup>2</sup> C compatibility timings	15
Table 3.	Temperature sensor registers summary	16
Table 4.	Pointer register format	17
Table 5.	Pointer register select bits (type, width, and default values)	17
Table 6.	Capability register format	17
Table 7.	Capability register bit definitions	18
Table 8.	Configuration register format	19
Table 9.	Configuration register bit definitions	20
Table 10.	Hysteresis as applied to temperature movement	21
Table 11.	Legend for <i>Figure 9: Event output boundary timings</i>	23
Table 12.	Temperature register format	24
Table 13.	Temperature register coding examples (for 10 bits)	25
Table 14.	Temperature register bit definitions	25
Table 15.	Temperature trip point register format	26
Table 16.	Alarm temperature upper boundary register format	26
Table 17.	Alarm temperature lower boundary register format	26
Table 18.	Critical temperature register format	27
Table 19.	Manufacturer ID register (read-only)	28
Table 20.	Device ID and device revision ID register (read-only)	28
Table 21.	Temperature resolution register (TRES) (read/write)	29
Table 22.	TRES details	29
Table 23.	Device select code	31
Table 24.	Operating modes	32
Table 25.	Acknowledge when writing data or defining the write-protection (instructions with R/W bit = 0) <sup>37</sup>	
Table 26.	Acknowledge when reading the write protection (instructions with R/W bit=1)	38
Table 27.	DRAM DIMM connections	39
Table 28.	Absolute maximum ratings	40
Table 29.	Operating and AC measurement conditions	41
Table 30.	DC/AC characteristics - temperature sensor component with EEPROM	41
Table 31.	TDFN8 – 8-lead thin dual flat, no-lead (2 mm x 3 mm) mechanical data (DN)	44
Table 32.	Parameters for landing pattern - TDFN8 package (DN)	47
Table 33.	Carrier tape dimensions TDFN8 package	48
Table 34.	Reel dimensions for 8 mm carrier tape - TDFN8 package	49
Table 35.	Ordering information scheme	50
Table 36.	Document revision history	51

## List of figures

Figure 1.	Logic diagram . . . . .	8
Figure 2.	TDFN8 connections (top view) . . . . .	8
Figure 3.	Block diagram . . . . .	9
Figure 4.	SMBus/I <sup>2</sup> C write to pointer register . . . . .	12
Figure 5.	SMBus/I <sup>2</sup> C write to pointer register, followed by a read data word. . . . .	12
Figure 6.	SMBus/I <sup>2</sup> C write to pointer register, followed by a write data word . . . . .	13
Figure 7.	SMBus/I <sup>2</sup> C timing diagram . . . . .	14
Figure 8.	Hysteresis . . . . .	21
Figure 9.	Event output boundary timings . . . . .	23
Figure 10.	Result of setting the write protection. . . . .	32
Figure 11.	Setting the write protection . . . . .	33
Figure 12.	Write mode sequences in a non write-protected area of SPD . . . . .	34
Figure 13.	Write cycle polling flowchart using ACK . . . . .	35
Figure 14.	Read mode sequences - SPD . . . . .	36
Figure 15.	AC measurement I/O waveform . . . . .	41
Figure 16.	TDFN8 – 8-lead thin dual flat, no-lead (2 mm x 3 mm) package outline (DN) . . . . .	44
Figure 17.	DN package topside marking information (TDFN8) . . . . .	45
Figure 18.	Landing pattern - TDFN8 package (DN) . . . . .	46
Figure 19.	Carrier tape for TDFN8 package . . . . .	48
Figure 20.	Reel schematic . . . . .	49

# 1 Description

The STTS2002 is targeted for DIMM modules in mobile personal computing platforms (laptops), servers and other industrial applications. The thermal sensor (TS) in the STTS2002 is compliant with the JEDEC specification TSE2002a2, which defines memory module thermal sensors requirements for mobile platforms. The 2 Kb serial presence detect (SPD) I<sup>2</sup>C-compatible electrically erasable programmable memory (EEPROM) in the STTS2002 is organized as 256 x8 bits and is functionally identical to the industry standard M34E02.

The TS-SPD EEPROM combination provides space as well as cost savings for mobile and server platform dual inline memory modules (DIMM) manufacturers, as it is packaged in the compact 2 mm x 3 mm 8-lead TDFN package with a thinner maximum height of 0.80 mm. The DN package is compliant to JEDEC MO-229, variation WCED-3.

The digital temperature sensor has a programmable 9-12 bit analog-to-digital converter (ADC) which monitors and digitizes the temperature to a resolution of up to 0.0625 °C. The default resolution is 0.25 °C/LSB (10-bit). The typical accuracies over these temperature ranges are:

- ±2 °C over the full temperature measurement range of –40 °C to 125 °C
- ±1 °C in the +40 °C to +125 °C active temperature range, and
- ±0.5 °C in the +75 °C to +95 °C monitor temperature range

The temperature sensor in the STTS2002 is specified for operating at supply voltages from 2.3 V to 3.6 V. Operating at 3.3 V, the typical supply current is 160 µA (includes SMBus communication current).

The on-board sigma delta ADC converts the measured temperature to a digital value that is calibrated in °C. For Fahrenheit applications, a lookup table or conversion routine is required. The STTS2002 is factory-calibrated and requires no external components to measure temperature.

The digital temperature sensor component has user-programmable registers that provide the capabilities for DIMM temperature-sensing applications. The open drain event output pin is active when the monitoring temperature exceeds a programmable limit, or it falls above or below an alarm window. The user has the option to set the event output as a critical temperature output. This pin can be configured to operate in either a comparator mode for thermostat operation or in interrupt mode.

The 2 Kb serial EEPROM memory in the STTS2002 has the ability to permanently lock the data in its first half (upper) 128 bytes (locations 00h to 7Fh). This feature has been designed specifically for use in DRAM DIMMs with SPD. All of the information concerning the DRAM module configuration (e.g. access speed, size, and organization) can be kept write protected in the first half of the memory. The second half (lower) 128 bytes of the memory can be write protected using two different software write protection mechanisms.

By sending the device a specific sequence, the first 128 bytes of the memory become write protected: permanently or resettable. In the STTS2002 the write protection of the memory array is dependent on whether the software protection has been set.

## 2 Serial communications

The STTS2002 has a simple 2-wire SMBus/I<sup>2</sup>C-compatible digital serial interface which allows the user to access both the 2 Kb serial EEPROM and the data in the temperature register at any time. It communicates via the serial interface with a master controller which operates at speeds of up to 400 kHz. It also gives the user easy access to all of the STTS2002 registers in order to customize device operation.

### 2.1 Device type identifier (DTI) code

The JEDEC temperature sensor and EEPROM each have their own unique I<sup>2</sup>C address, which ensures that there are no compatibility or data translation issues. This is due to the fact that each of the devices have their own 4-bit DTI code, while the remaining three bits are configurable. This enables the EEPROM and thermal sensors to provide their own individual data via their unique addresses and still not interfere with each other's operation in any way. The DTI codes are:

- '0011' for the TS, and
- '1010' for addressing the EEPROM memory array, and
- '0110' to access the software write protection settings of the EEPROM.

**Figure 1. Logic diagram**

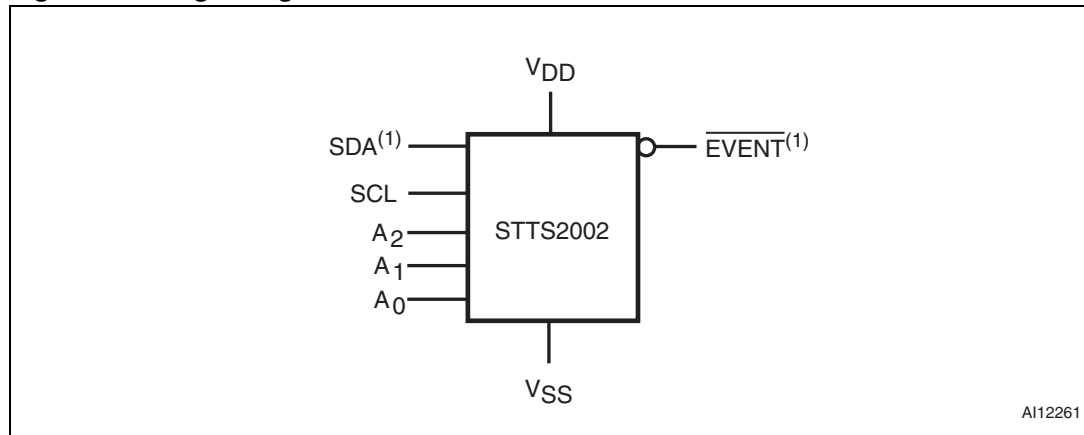

1. SDA and  $\overline{\text{EVENT}}$  are open drain.

**Table 1. Signal names**

Pin	Symbol	Description	Direction
1	A0	Serial bus address selection pin. Can be tied to $V_{SS}$ or $V_{DD}$ .	Input
2	A1	Serial bus address selection pin. Can be tied to $V_{SS}$ or $V_{DD}$ .	Input
3	A2	Serial bus address selection pin. Can be tied to $V_{SS}$ or $V_{DD}$ .	Input
4	$V_{SS}$	Supply ground	
5	$\text{SDA}^{(1)}$	Serial data	Input/output
6	SCL	Serial clock	Input
7	$\overline{\text{EVENT}}^{(1)}$	Event output pin. Open drain and active-low.	Output
8	$V_{DD}$	Supply power (2.3 V to 3.6 V)	

1. SDA and  $\overline{\text{EVENT}}$  are open drain.

*Note:* See [Section 2.2: Pin descriptions on page 10](#) for details.

**Figure 2. TDFN8 connections (top view)**

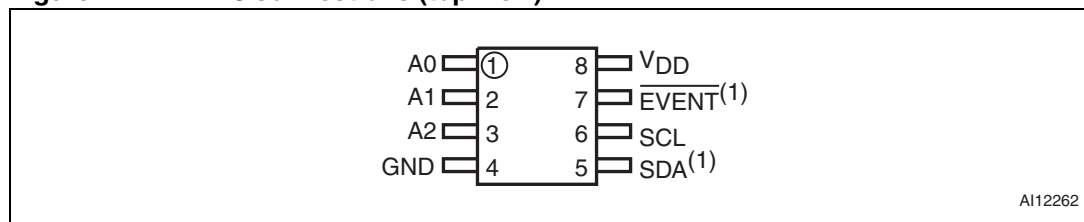

1. SDA and  $\overline{\text{EVENT}}$  are open drain.



Figure 3. Block diagram

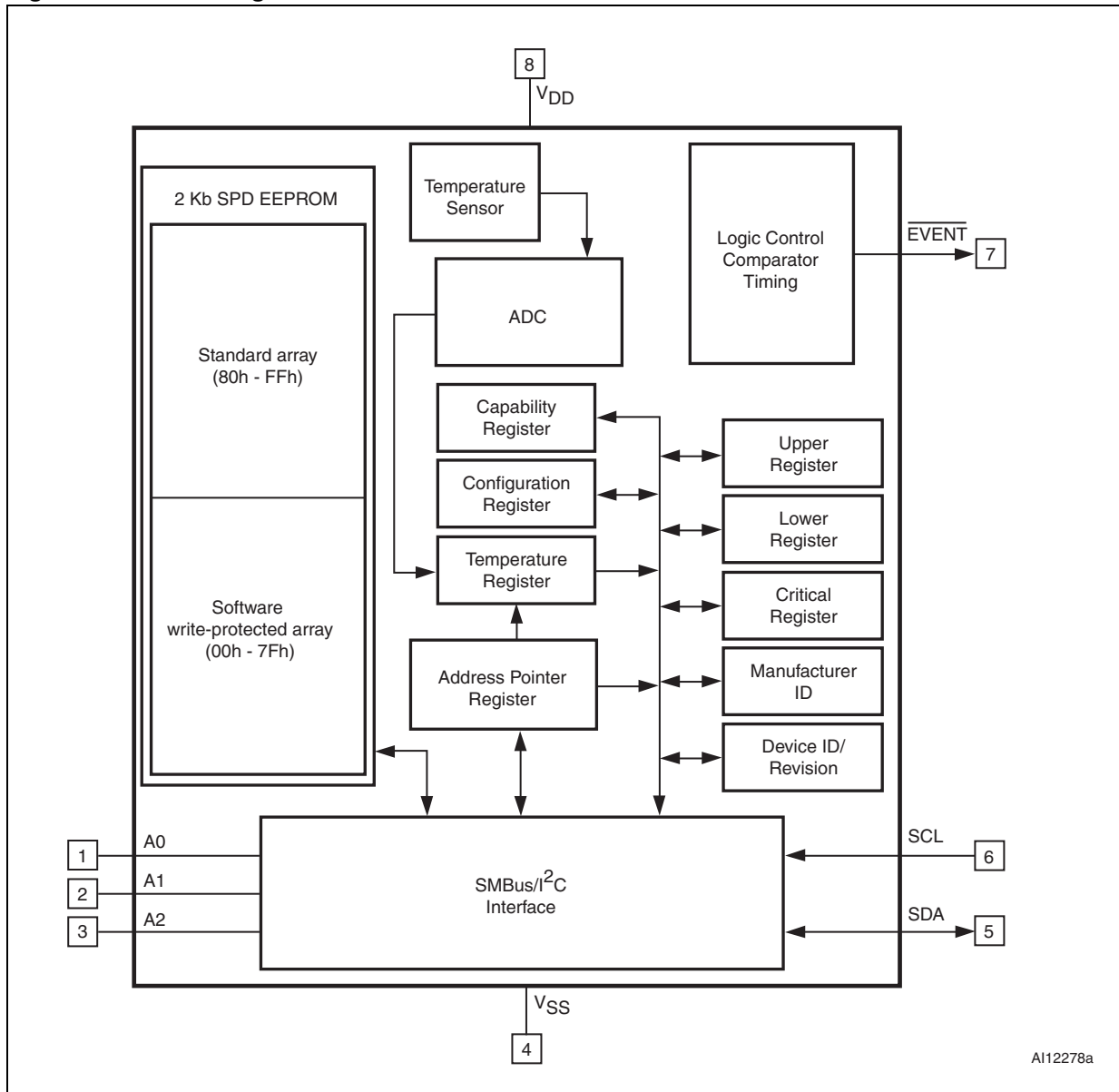

AI12278a

## 2.2 Pin descriptions

### 2.2.1 A0, A1, A2

A2, A1, and A0 are selectable address pins for the 3 LSBs of the I<sup>2</sup>C interface address. They can be set to V<sub>DD</sub> or GND to provide 8 unique address selections. These pins are internally connected to the E2, E1, E0 (chip selects) of EEPROM.

### 2.2.2 V<sub>SS</sub> (ground)

This is the reference for the power supply. It must be connected to system ground.

### 2.2.3 SDA (open drain)

This is the serial data input/output pin.

### 2.2.4 SCL

This is the serial clock input pin.

### 2.2.5 $\overline{\text{EVENT}}$ (open drain)

This output pin is open drain and active-low.

### 2.2.6 V<sub>DD</sub> (power)

This is the supply voltage pin, and ranges from 2.3 V to 3.6 V.

## 3 Temperature sensor operation

The temperature sensor continuously monitors the ambient temperature and updates the temperature data register. Temperature data is latched internally by the device and may be read by software from the bus host at any time.

The SMBus/I<sup>2</sup>C slave address selection pins allow up to 8 such devices to co-exist on the same bus. This means that up to 8 memory modules can be supported, given that each module has one such slave device address slot.

After initial power-on, the configuration registers are set to the default values. The software can write to the configuration register to set bits per the bit definitions in [Section 3.1: SMBus/I<sup>2</sup>C communications](#).

For details of operation and usage of 2 Kb SPD EEPROM, refer to [Section 5: SPD EEPROM operation](#).

### 3.1 SMBus/I<sup>2</sup>C communications

The registers in this device are selected by the pointer register. At power-up, the pointer register is set to "00", which is the capability register location. The pointer register latches the last location it was set to. Each data register falls into one of three types of user accessibility:

1. Read-only
2. Write-only, and
3. WRITE/READ same address

A WRITE to this device will always include the address byte and the pointer byte. A WRITE to any register other than the pointer register, requires two data bytes.

Reading this device is achieved in one of two ways:

- If the location latched in the pointer register is correct (most of the time it is expected that the pointer register will point to one of the read temperature registers because that will be the data most frequently read), then the READ can simply consist of an address byte, followed by retrieval of the two data bytes.
- If the pointer register needs to be set, then an address byte, pointer byte, repeat start, and another address byte will accomplish a READ.

The data byte transfers the MSB first. At the end of a READ, this device can accept either an acknowledge (ACK) or no acknowledge (No ACK) status from the master. The No ACK status is typically used as a signal for the slave that the master has read its last byte. This device subsequently takes up to 125 ms to measure the temperature for the default temperature resolution.

*Note:* STTS2002 does not initiate clock stretching which is an optional I<sup>2</sup>C bus feature.

Figure 4. SMBus/I<sup>2</sup>C write to pointer register

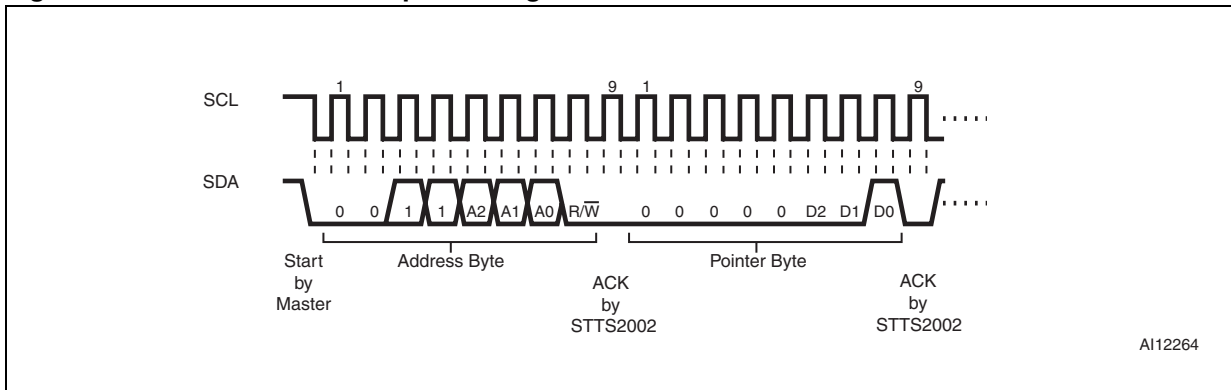
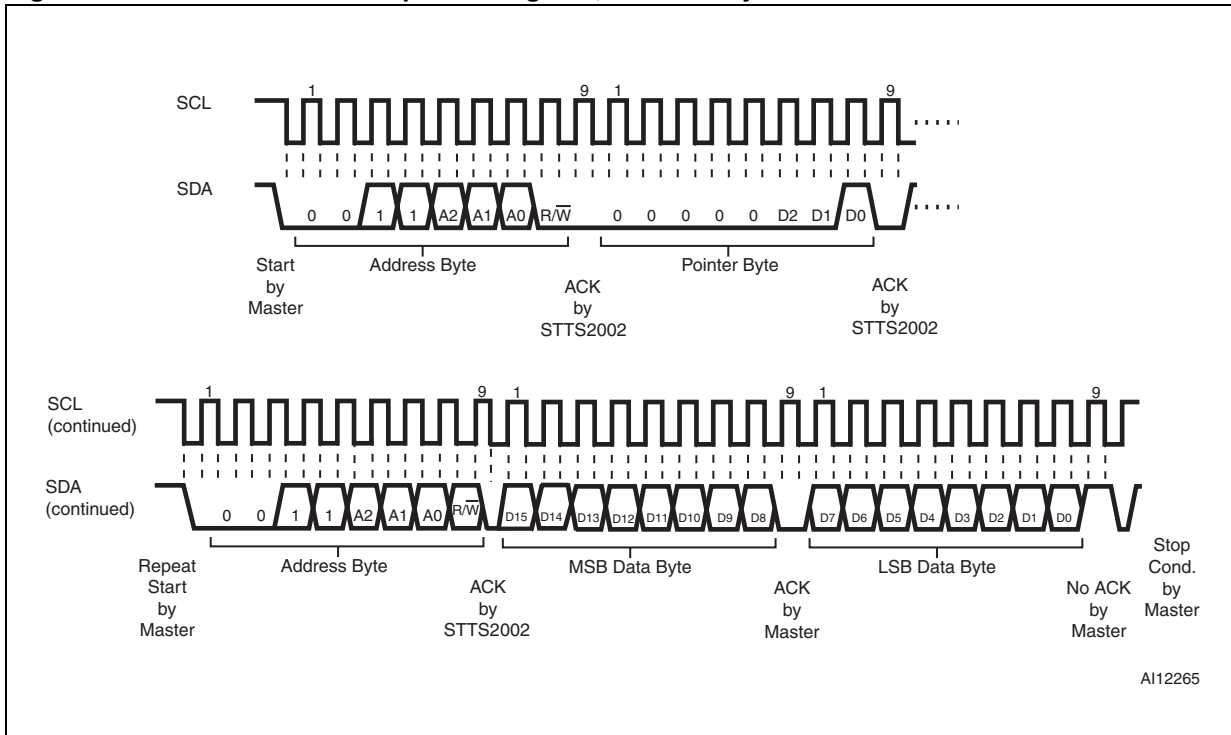
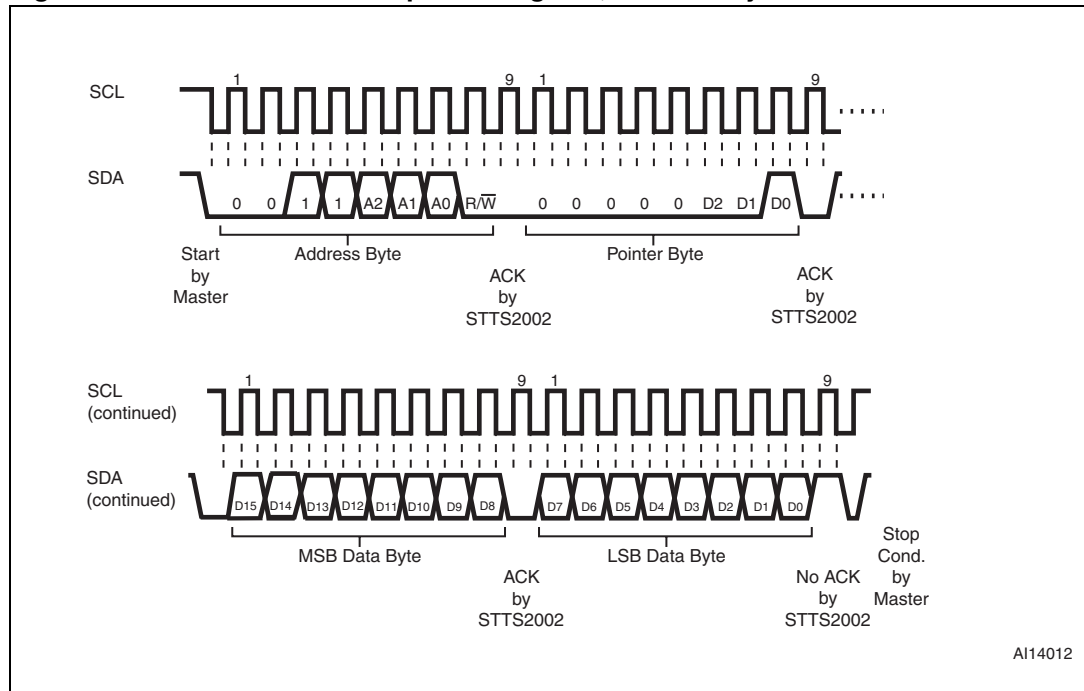

Figure 5. SMBus/I<sup>2</sup>C write to pointer register, followed by a read data word



**Figure 6. SMBus/I<sup>2</sup>C write to pointer register, followed by a write data word**



### 3.2 SMBus/I<sup>2</sup>C slave sub-address decoding

The physical address for the TS is different than that used by the EEPROM. The TS physical address is binary 0 0 1 1 A2 A1 A0 RW, where A2, A1, and A0 are the three slave sub-address pins, and the LSB "RW" is the READ/WRITE flag.

The EEPROM physical address is binary 1 0 1 0 A2 A1 A0 RW for the memory array and is 0 1 1 0 A2 A1 A0 RW for permanently set write protection mode.

### 3.3 SMBus/I<sup>2</sup>C AC timing consideration

In order for this device to be both SMBus- and I<sup>2</sup>C-compatible, it complies to a subset of each specification. The requirements which enable this device to co-exist with devices on either an SMBus or an I<sup>2</sup>C bus include:

- The SMBus minimum clock frequency is required.
- The SMBus timeout is maximum 35 ms (temperature sensor only).

Figure 7. SMBus/I<sup>2</sup>C timing diagram

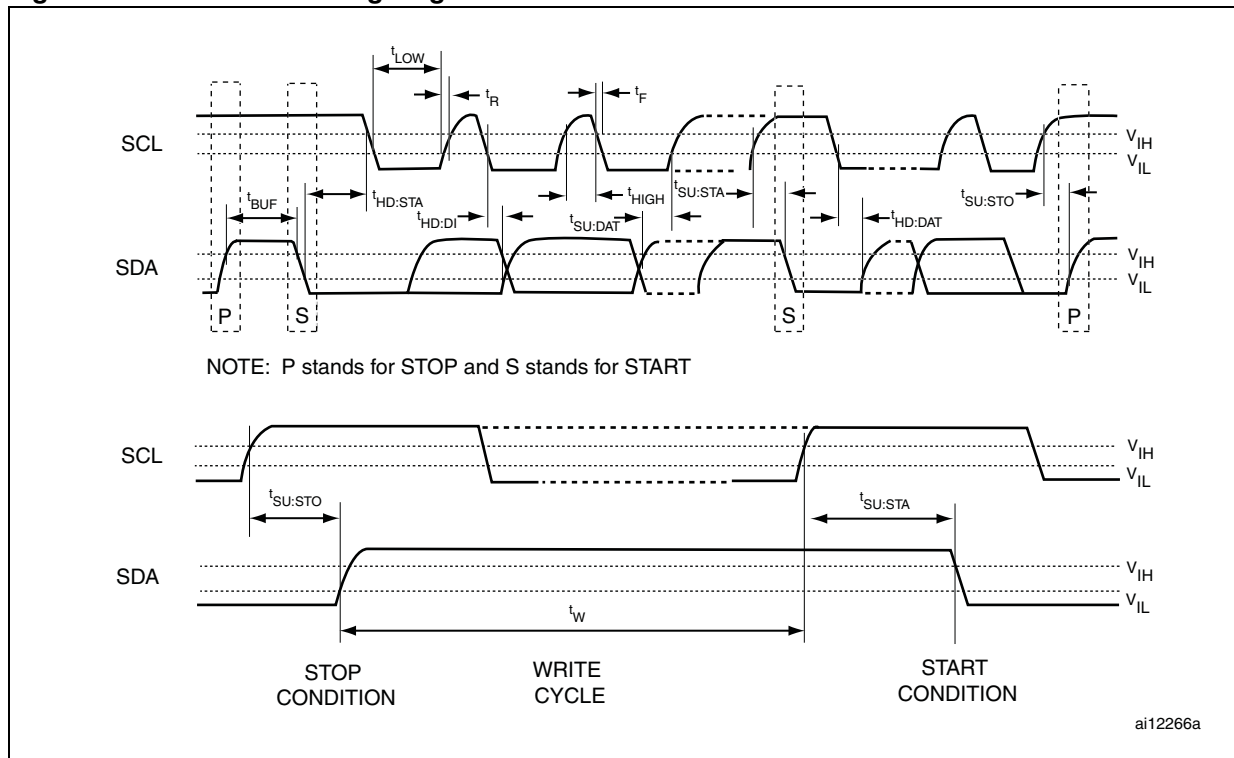

**Table 2. AC characteristics of STTS2002 for SMBus and I<sup>2</sup>C compatibility timings**

Symbol	Parameter	Min	Max	Units
f <sub>SCL</sub>	SMBUS/I <sup>2</sup> C clock frequency	10	400	kHz
t <sub>HIGH</sub>	Clock high period	600	–	ns
t <sub>LOW</sub> <sup>(1)</sup>	Clock low period	1300	–	ns
t <sub>R</sub> <sup>(2)</sup>	Clock/data rise time	–	300	ns
t <sub>F</sub> <sup>(2)</sup>	Clock/data fall time	20	300	ns
t <sub>SU:DAT</sub>	Data in setup time	100	–	ns
t <sub>HD:DI</sub>	Data in hold time	0	–	ns
t <sub>HD:DAT</sub>	Data out hold time	200	900	ns
t <sub>SU:STA</sub> <sup>(3)</sup>	Repeated start condition setup time	600	–	ns
t <sub>HD:STA</sub>	Hold time after (repeated) start condition. After this period, the first clock cycle is generated.	600	–	ns
t <sub>SU:STO</sub>	Stop condition setup time	600	–	ns
t <sub>BUF</sub>	Bus free time between stop (P) and start (S) conditions	1300	–	ns
t <sub>W</sub> <sup>(4)</sup>	WRITE time for EEPROM	–	10	ms
t <sub>timeout</sub> <sup>(5)</sup>	Bus timeout (temperature sensor only)	25	35	ms

1. STTS2002 will not initiate clock stretching which is an I<sup>2</sup>C bus optional feature.
2. Guaranteed by design and characterization, not necessarily tested.
3. For a restart condition, or following a WRITE cycle.
4. This parameter reflects maximum WRITE time for EEPROM.
5. Bus timeout value supported depends on setting of TMOUT bit 6 in capability register.

## 4 Temperature sensor registers

The temperature sensor component is comprised of various user-programmable registers. These registers are required to write their corresponding addresses to the pointer register. They can be accessed by writing to their respective addresses (see [Table 3](#)). Pointer register bits 7 - 4 must always be written to '0' (see [Table 4](#)). This must be maintained, as not setting these bits to '0' may keep the device from performing to specifications.

The main registers include:

- [Capability register \(read-only\)](#)
- [Configuration register \(read/write\)](#)
- [Temperature register \(read-only\)](#)
- [Temperature trip point registers \(read/write\)](#), including
  - Alarm temperature upper boundary,
  - Alarm temperature lower boundary, and
  - Critical temperature.
- [Manufacturer ID register \(read-only\)](#)
- [Device ID and device revision ID register \(read-only\)](#)
- [Temperature resolution register \(TRES\) \(read/write\)](#)

See [Table 5 on page 17](#) for pointer register selection bit details.

**Table 3. Temperature sensor registers summary**

Address (hex)	Register name		Power-on default
Not applicable	Address pointer		Undefined
00	Capability	B-grade	0x006F
01	Configuration		0x0000
02	Alarm temperature upper boundary trip		0x0000
03	Alarm temperature lower boundary trip		0x0000
04	Critical temperature trip		0x0000
05	Temperature		Undefined
06	Manufacturer's ID		0x104A
07	Device ID/revision		0x0300
08	Temperature resolution register		0x0001

*Note:* Registers beyond the specified (00-08) are reserved for STMicroelectronics internal use only, for device test modes in product manufacturing. The registers must NOT be accessed by the user (customer) in the system application or the device may not perform according to specifications.



**Table 4. Pointer register format**

<b>MSB</b>							<b>LSB</b>
<b>Bit7</b>	<b>Bit6</b>	<b>Bit5</b>	<b>Bit4</b>	<b>Bit3</b>	<b>Bit2</b>	<b>Bit1</b>	<b>Bit0</b>
0	0	0	0	P3	P2	P1	P0
Pointer/register select bits							

**Table 5. Pointer register select bits (type, width, and default values)**

P3	P2	P1	P0	Name	Register description	Width (bits)	Type (R/W)	Default state (POR)
0	0	0	0	CAPA	Thermal sensor capabilities B-grade only	16	R	00 6F
0	0	0	1	CONF	Configuration	16	R/W	00 00
0	0	1	0	UPPER	Alarm temperature upper boundary	16	R/W	00 00
0	0	1	1	LOWER	Alarm temperature lower boundary	16	R/W	00 00
0	1	0	0	CRITICAL	Critical temperature	16	R/W	00 00
0	1	0	1	TEMP	Temperature	16	R	00 00
0	1	1	0	MANU	Manufacturer ID	16	R	10 4A
0	1	1	1	ID	Device ID/revision	16	R	03 00
1	0	0	0	TRES	Temperature resolution register	8	R/W	01

### 4.1 Capability register (read-only)

This 16-bit register is read-only, and provides the TS capabilities which comply with the minimum JEDEC TSE2002a2 specifications (see [Table 6](#) and [Table 7 on page 18](#)). The STTS2002 resolution is programmable via writing to pointer 08 register. The power-on default value is 0.25 °C/LSB (10-bit).

**Table 6. Capability register format**

<b>Bit15</b>	<b>Bit14</b>	<b>Bit13</b>	<b>Bit12</b>	<b>Bit11</b>	<b>Bit10</b>	<b>Bit9</b>	<b>Bit8</b>
RFU	RFU	RFU	RFU	RFU	RFU	RFU	RFU
<b>Bit7</b>	<b>Bit6</b>	<b>Bit5</b>	<b>Bit4</b>	<b>Bit3</b>	<b>Bit2</b>	<b>Bit1</b>	<b>Bit0</b>
EVSD	TMOUT	V <sub>HV</sub>	TRES1	TRES0	Wider range	Higher precision	Alarm and critical trips

Table 7. Capability register bit definitions

Bit	Definition
0	Basic capability – 0 = Alarm and critical trips turned OFF. – 1 = <b>Alarm and critical trips turned ON.</b>
1	Accuracy – 0 = Accuracy $\pm 2$ °C over the active range and $\pm 3$ °C over the monitoring range (C-grade). – 1 = <b>High accuracy <math>\pm 1</math> °C over the active range and <math>\pm 2</math> °C over the monitoring range (B-grade) (default).</b>
2	Range width – 0 = Values lower than 0 °C will be clamped and represented as binary value '0'. – 1 = <b>Temperatures below 0 °C can be read and the Sign bit will be set accordingly.</b>
4:3	Temperature resolution – 00 = 9 bit, 0.5 °C/LSB – 01 = <b>10 bit, 0.25 °C/LSB - default resolution</b> – 10 = 11 bit, 0.125 °C/LSB – 11 = 12 bit, 0.0625 °C/LSB
5	(V <sub>HV</sub> ) high voltage support for A0 (pin 1) – 1 = <b>STTS2002 supports a voltage up to 10 volts on the A0 pin - (default)</b>
6	TMOUT - bus timeout support (for temperature sensor only) – 0 = t <sub>timeout</sub> is supported in the range of 10 to 60 ms – 1 = <b>Default for STTS2002-SMBus compatible 25 ms - 35 ms</b> Note: Timeout is not required for EEPROM component
7	EVSD - $\overline{\text{EVENT}}$ behavior upon shutdown – 0 = <b>Default for STTS2002. The <math>\overline{\text{EVENT}}</math> output freezes in its current state when entering shutdown. Upon entering shutdown, the <math>\overline{\text{EVENT}}</math> output remains in the previous state until the next thermal data conversion or possibly sooner if <math>\overline{\text{EVENT}}</math> is programmed for comparator mode.</b> – 1 = $\overline{\text{EVENT}}$ output is deasserted (not driven) when entering shutdown and remains deasserted upon exit from shutdown until the next thermal sample is taken or possibly sooner if $\overline{\text{EVENT}}$ is programmed for comparator mode.
15:8	Reserved <b>These values must be set to '0'.</b>

## 4.2 Configuration register (read/write)

The 16-bit configuration register stores various configuration modes that are used to set up the sensor registers and configure according to application and JEDEC requirements (see [Table 8 on page 19](#) and [Table 9 on page 20](#)).

### 4.2.1 Event thresholds

All event thresholds use hysteresis as programmed in register address 0x01 (bits 10 through 9) to be set when they de-assert.

### 4.2.2 Interrupt mode

The interrupt mode allows an event to occur where software may write a '1' to the clear event bit (bit 5) to de-assert the event Interrupt output until the next trigger condition occurs.

### 4.2.3 Comparator mode

Comparator mode enables the device to be used as a thermostat. READs and WRITEs on the device registers will not affect the event output in comparator mode. The event signal will remain asserted until temperature drops outside the range or is re-programmed to make the current temperature “out of range”.

### 4.2.4 Shutdown mode

The STTS2002 features a shutdown mode which disables all power-consuming activities (e.g. temperature sampling operations), and leaves the serial interface active. This is selected by setting shutdown bit (bit 8) to '1'. In this mode, the devices consume the minimum current ( $I_{SHDN}$ ), as shown in [Table 30 on page 41](#).

*Note: Bit 8 cannot be set to '1' while bits 6 and 7 (the lock bits) are set to '1'.*

The device may be enabled for continuous operation by clearing bit 8 to '0'. In shutdown mode, all registers may be read or written to. Power recycling will also clear this bit and return the device to continuous mode as well.

**Table 8. Configuration register format**

Bit15	Bit14	Bit13	Bit12	Bit11	Bit10	Bit9	Bit8
RFU	RFU	RFU	RFU	RFU	Hysteresis	Hysteresis	Shutdown mode
Bit7	Bit6	Bit5	Bit4	Bit3	Bit2	Bit1	Bit0
Critical lock bit	Alarm lock bit	Clear event	Event output status	Event output control	Critical event only	Event polarity	Event mode

Table 9. Configuration register bit definitions

Bit	Definition
0	Event mode – <b>0 = Comparator output mode (this is the default).</b> – 1 = Interrupt mode; when either of the lock bits (bit6 or bit7) is set, this bit cannot be altered until it is unlocked.
1	Event polarity <sup>(1)</sup> The event polarity bit controls the active state of the EVENT pin. The EVENT pin is driven to this state when it is asserted. – <b>0 = Active-low (this is the default). Requires a pull-up resistor to set the inactive state of the open-drain output. The power to the pull-up resistor should not be greater than <math>V_{DD} + 0.2</math> V. Active state is logical “0”.</b> – 1 = Active-high. The active state of the pin is then logical “1”.
2	Critical event only – <b>0 = Event output on alarm or critical temperature event (this is the default).</b> – 1 = Event only if the temperature is above the value in the critical temperature register ( $T_A > T_{CRIT}$ ); when the alarm window lock bit (bit6) is set, this bit cannot be altered until it is unlocked.
3	Event output control – <b>0 = Event output disabled (this is the default).</b> – 1 = Event output enabled; when either of the lock bits (bit6 or bit7) is set, this bit cannot be altered until it is unlocked.
4	Event status (read-only) <sup>(2)</sup> – <b>0 = Event output condition is not being asserted by this device.</b> – 1 = Event output condition is being asserted by this device via the alarm window or critical trip event.
5	Clear event (write-only) <sup>(3)</sup> – <b>0 = No effect.</b> – 1 = Clears the active event in interrupt mode. The pin is released and will not assert until a new interrupt condition occurs.
6	Alarm window lock bit – <b>0 = Alarm trips are not locked and can be altered (this is the default).</b> – 1 = Alarm trip register settings cannot be altered. This bit is initially cleared. When set, this bit returns a logic '1' and remains locked until cleared by an internal power-on reset. These bits can be written to with a single WRITE, and do not require double WRITES.
7	Critical trip lock bit – <b>0 = Critical trip is not locked and can be altered (this is the default).</b> – 1 = Critical trip register settings cannot be altered. This bit is initially cleared. When set, this bit returns a logic '1' and remains locked until cleared by an internal power-on reset. These bits can be written to with a single WRITE, and do not require double WRITES.
8	Shutdown mode – <b>0 = TS is enabled, continuous conversion (this is the default).</b> – 1 = Shutdown TS when the shutdown, device, and A/D converter are disabled in order to save power. No event conditions will be asserted; when either of the lock bits (bit6 or bit7) is set, then this bit cannot be altered until it is unlocked. It can be cleared at any time.

**Table 9. Configuration register bit definitions (continued)**

Bit	Definition
10:9	Hysteresis enable (see <a href="#">Figure 8</a> and <a href="#">Table 10</a> ) – 00 = Hysteresis is disabled (default) – 01 = Hysteresis is enabled at 1.5 °C – 10 = Hysteresis is enabled at 3 °C – 11 = Hysteresis is enabled at 6 °C  Hysteresis applies to all limits when the temperature is dropping below the threshold so that once the temperature is above a given threshold, it must drop below the threshold minus the hysteresis in order to be flagged as an interrupt event. Note that hysteresis is also applied to the $\overline{\text{EVENT}}$ pin functionality. When either of the lock bits is set, these bits cannot be altered.
15:11	<b>Reserved for future use. These bits will always read '0' and writing to them will have no effect. For future compatibility, all RFU bits must be programmed as '0'.</b>

- As this device is used in DIMM (memory modules) applications, it is strongly recommended that only the active-low polarity (default) is used. This will provide full compatibility with the STTS424E02. This is the recommended configuration for the STTS2002.
- The actual incident causing the event can be determined from the read temperature register. Interrupt events can be cleared by writing to the clear event bit (writing to this bit will have no effect on overall device functioning).
- Writing to this register has no effect on overall device functioning in comparator mode. When read, this bit will always return a logic '0' result.

**Figure 8. Hysteresis**

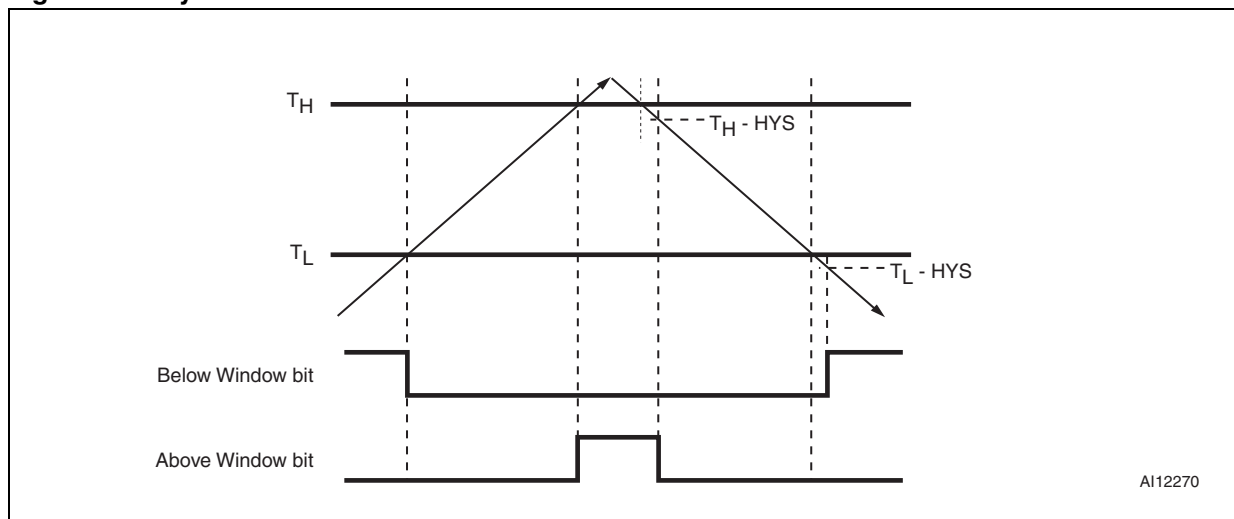

- $T_H$  = Value stored in the alarm temperature upper boundary trip register
- $T_L$  = Value stored in the alarm temperature lower boundary trip register
- HYS = Absolute value of selected hysteresis

**Table 10. Hysteresis as applied to temperature movement**

	Below alarm window bit		Above alarm window bit	
	Temperature slope	Temperature threshold	Temperature slope	Temperature threshold
Sets	Falling	$T_L - \text{HYS}$	Rising	$T_H$
Clears	Rising	$T_L$	Falling	$T_H - \text{HYS}$

### 4.2.5 Event output pin functionality

The STTS2002  $\overline{\text{EVENT}}$  pin is an open drain output that requires a pull-up to  $V_{DD}$  on the system motherboard or integrated into the master controller.  $\overline{\text{EVENT}}$  has three operating modes, depending on configuration settings and any current out-of-limit conditions. These modes are interrupt, comparator or critical.

In interrupt mode the  $\overline{\text{EVENT}}$  pin will remain asserted until it is released by writing a '1' to the "Clear Event" bit in the status register. The value to write is independent of the  $\overline{\text{EVENT}}$  polarity bit.

In comparator mode the  $\overline{\text{EVENT}}$  pin will clear itself when the error condition that caused the pin to be asserted is removed.

In the critical mode the  $\overline{\text{EVENT}}$  pin will only be asserted if the measured temperature exceeds the critical limit. Once the pin has been asserted, it will remain asserted until the temperature drops below the critical limit minus hysteresis. [Figure 9 on page 23](#) illustrates the operation of the different modes over time and temperature.

When the hysteresis bits (bits 10 and 9) are enabled, hysteresis may be used to sense temperature movement around trigger points. For example, when using the "above alarm window" bit (temperature register bit 14, see [Table 12 on page 24](#)) and hysteresis is set to 3 °C, as the temperature rises, bit 14 is set (bit 14 = 1). The temperature is above the alarm window and the temperature register contains a value that is greater than the value set in the alarm temperature upper boundary register (see [Table 16 on page 26](#)).

If the temperature decreases, bit 14 will remain set until the measured temperature is less than or equal to the value in the alarm temperature upper boundary register minus 3 °C (see [Figure 8 on page 21](#) and [Table 10 on page 21](#) for details).

Similarly, when using the "below alarm window" bit (temperature register bit 13, see [Table 12 on page 24](#)) will be set to '0'. The temperature is equal to or greater than the value set in the alarm temperature lower boundary register (see [Table 17 on page 26](#)). As the temperature decreases, bit 13 will be set to '1' when the value in the temperature register is less than the value in the alarm temperature lower boundary register minus 3 °C (see [Figure 8 on page 21](#) and [Table 10 on page 21](#) for details).

The device will retain the previous state when entering the shutdown mode. If the device enters the shutdown mode while the  $\overline{\text{EVENT}}$  pin is low, the shutdown current will increase due to the additional event output pull-down current.

Figure 9. Event output boundary timings

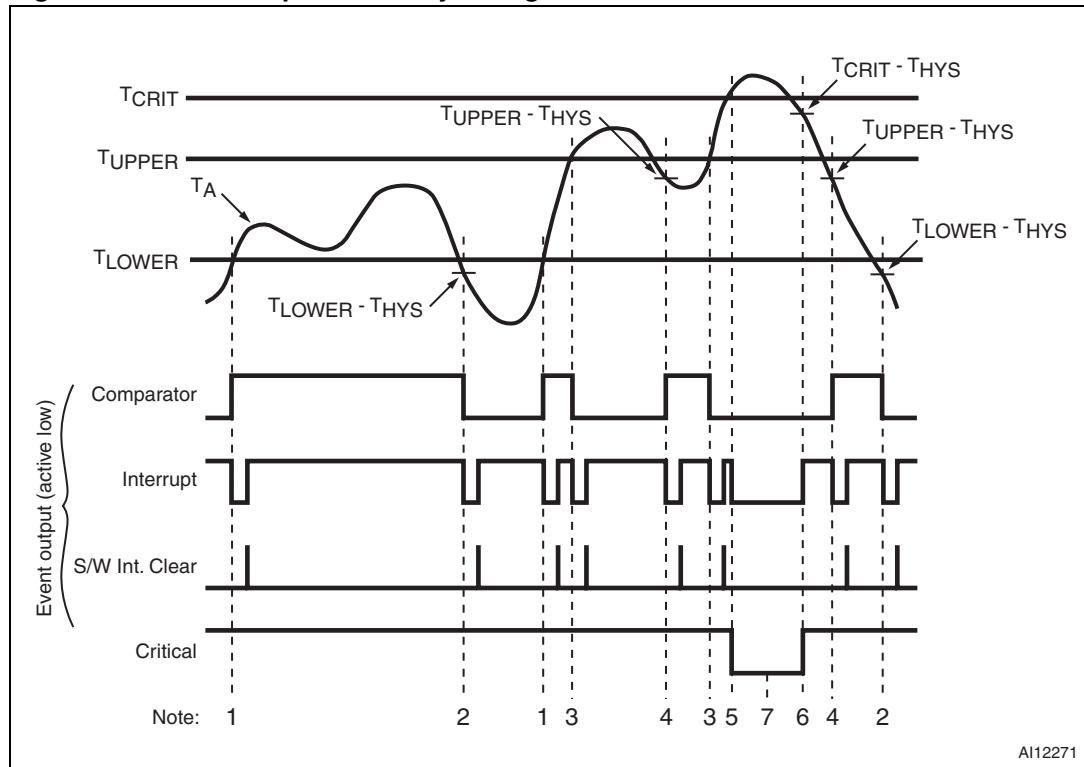

AI12271

Table 11. Legend for *Figure 9: Event output boundary timings*

Note	Event output boundary conditions	Event output			T <sub>A</sub> bits		
		Comparator	Interrupt	Critical	15	14	13
1	$T_A \geq T_{LOWER}$	H	L	H	0	0	0
2	$T_A < T_{LOWER} - T_{HYS}$	L	L	H	0	0	1
3	$T_A > T_{UPPER}$	L	L	H	0	1	0
4	$T_A \leq T_{UPPER} - T_{HYS}$	H	L	H	0	0	0
5	$T_A \geq T_{CRIT}$	L	L	L	1	0	0
6	$T_A < T_{CRIT} - T_{HYS}$	L	H	H	0	1	0
7	When $T_A \geq T_{CRIT}$ and $T_A < T_{CRIT} - T_{HYS}$ , the event output is in comparator mode and bit 0 of the configuration register (interrupt mode) is ignored.						

Systems that use the active high mode for Event output must be wired point-to-point between the STTS2002 and the sensing controller. Wire-OR configurations should not be used with active high Event output since any device pulling the Event output signal low will mask the other devices on the bus. Also note that the normal state of Event output in active high mode is a '0' which will constantly draw power through the pull-up resistor.

### 4.3 Temperature register (read-only)

This 16-bit, read-only register stores the temperature measured by the internal band gap TS as shown in [Table 12](#). When reading this register, the MSBs (bit 15 to bit 8) are read first, and then the LSBs (bit 7 to bit 0) are read. The result is the current-sensed temperature. The data format is 2s complement with one LSB = 0.25 °C for the default resolution. The MSB has a 128 °C resolution.

The trip status bits represent the internal temperature trip detection, and are not affected by the status of the event or configuration bits (e.g. event output control or clear event). If neither of the above or below values are set (i.e. both are 0), then the temperature is exactly within the user-defined alarm window boundaries.

#### 4.3.1 Temperature format

The 16-bit value used in the trip point set and temperature read-back registers is 2s complement, with the LSB equal to 0.0625 °C (see [Table 12](#)). For example:

1. a value of 019C h represents 25.75 °C,
2. a value of 07C0 h represents 124 °C, and
3. a value of 1E74 h represents -24.75 °C

All unused resolution bits are set to zero. The MSB will have a resolution of 128 °C. The STTS2002 supports programmable resolutions (9-12 bits) which is 0.5 to 0.0625 °C/LSB. The default is 0.25 °C/LSB (10 bits) programmable.

The upper 3 bits indicate trip status based on the current temperature, and are not affected by the event output status.

**Table 12. Temperature register format**

			Sign MSB										LSB <sup>(1)</sup>			
Bit 15	Bit 14	Bit 13	Bit 12	Bit 11	Bit 10	Bit 9	Bit 8	Bit 7	Bit 6	Bit 5	Bit 4	Bit 3	Bit 2	Bit 1 <sup>(2)</sup>	Bit 0 <sup>(3)</sup>	
Flag bit	Flag bit	Flag bit	Sign	128	64	32	16	8	4	2	1	0.5	0.25	0.125	0.0625	°C/LSB
Above critical input <sup>(4)</sup>	Above alarm window <sup>(4)</sup>	Below alarm window <sup>(4)</sup>	Temperature (default - 10 bit)											0	0	
Flag bits			Example hex value of 07C0 corresponds to 124 °C (10-bit)													
0	0	0	0	0	1	1	1	1	1	0	0	0	0	0	0	07C0 h
Flag bits			Example hex value of 1D80 corresponds to -40 °C (10-bit)													
0	0	0	1	1	1	0	1	1	0	0	0	0	0	0	0	1D80 h

1. Bit 2 is LSB for default 10-bit mode.
2. Depending on status of the resolution register, bit 1 may display 0.125 °C value.
3. Depending on status of the resolution register, bit 0 may display 0.0625 °C value.
4. See [Table 14](#) for explanation.



A 0.25 °C minimum granularity is supported in all registers. Examples of valid settings and interpretation of temperature register bits for 10-bit (0.25 °C) default resolution are provided in [Table 13](#).

**Table 13. Temperature register coding examples (for 10 bits)**

B15:B0 (binary)	Value	Units
xxx0 0000 0010 11xx	+2.75	°C
xxx0 0000 0001 00xx	+1.00	°C
xxx0 0000 0000 01xx	+0.25	°C
xxx0 0000 0000 00xx	0	°C
xxx1 1111 1111 11xx	-0.25	°C
xxx1 1111 1110 00xx	-1.00	°C
xxx1 1111 1101 11xx	-2.25	°C

**Table 14. Temperature register bit definitions**

Bit	Definition with hysteresis = 0
13	Below (temperature) alarm window – 0 = Temperature is equal to or above the alarm window lower boundary temperature. – 1 = Temperature is below the alarm window.
14	Above (temperature) alarm window. – 0 = Temperature is equal to or below the alarm window upper boundary temperature. – 1 = Temperature is above the alarm window.
15	Above critical trip – 0 = Temperature is below the critical temperature setting. – 1 = Temperature is equal to or above the critical temperature setting.

## 4.4 Temperature trip point registers (read/write)

The STTS2002 alarm mode registers provide for 11-bit data in 2s compliment format. The data provides for one LSB = 0.25 °C. All unused bits in these registers are read as '0'.

The STTS2002 has three temperature trip point registers (see [Table 15](#)):

- Alarm temperature upper boundary threshold ([Table 16](#)),
- Alarm temperature lower boundary threshold ([Table 17](#)), and
- Critical temperature trip point value ([Table 18](#)).

*Note: If the upper or lower boundary threshold values are being altered in-system, all interrupts should be turned off until a known state can be obtained to avoid superfluous interrupt activity.*

**Table 15. Temperature trip point register format**

P3	P2	P1	P0	Name	Register description	Width (bits)	Type (R/W)	Default state (POR)
0	0	1	0	UPPER	Alarm temperature upper boundary	16	R/W	00 00
0	0	1	1	LOWER	Alarm temperature lower boundary	16	R/W	00 00
0	1	0	0	CRITICAL	Critical temperature	16	R/W	00 00

#### 4.4.1 Alarm window trip

The device provides a comparison window with an upper temperature trip point in the alarm upper boundary register, and a lower trip point in the alarm lower boundary register. When enabled, the event output will be triggered whenever entering or exiting (crossing above or below) the alarm window.

#### 4.4.2 Critical trip

The device can be programmed in such a way that the event output is only triggered when the temperature exceeds the critical trip point. The critical temperature setting is programmed in the critical temperature register. When the temperature sensor reaches the critical temperature value in this register, the device is automatically placed in comparator mode, which means that the critical event output cannot be cleared by using software to set the clear event bit.

**Table 16. Alarm temperature upper boundary register format**

			Sign MSB											LSB <sup>(1)</sup>		
Bit 15	Bit 14	Bit 13	Bit 12	Bit 11	Bit 10	Bit 9	Bit 8	Bit 7	Bit 6	Bit 5	Bit 4	Bit 3	Bit 2	Bit <sup>(2)</sup> 1	Bit <sup>(3)</sup> 0	
0	0	0	Alarm window upper boundary temperature										0	0		

1. Bit 2 is LSB for default 10-bit mode.
2. Depending on status of the resolution register, bit 1 may display 0.125 °C value.
3. Depending on status of the resolution register, bit 0 may display 0.0625 °C value.

**Table 17. Alarm temperature lower boundary register format**

			Sign MSB											LSB <sup>(1)</sup>		
Bit 15	Bit 14	Bit 13	Bit 12	Bit 11	Bit 10	Bit 9	Bit 8	Bit 7	Bit 6	Bit 5	Bit 4	Bit 3	Bit 2	Bit <sup>(2)</sup> 1	Bit <sup>(3)</sup> 0	
0	0	0	Alarm window lower boundary temperature										0	0		

1. Bit 2 is LSB for default 10-bit mode.
2. Depending on status of the resolution register, bit 1 may display 0.125 °C value.
3. Depending on status of the resolution register, bit 0 may display 0.0625 °C value.

**Table 18. Critical temperature register format**

			Sign MSB										LSB <sup>(1)</sup>		
Bit 15	Bit 14	Bit 13	Bit 12	Bit 11	Bit 10	Bit 9	Bit 8	Bit <sup>(2)</sup> 7	Bit 6	Bit 5	Bit 4	Bit 3	Bit 2	Bit <sup>(3)</sup> 1	Bit <sup>(4)</sup> 0
0	0	0	Critical temperature trip point											0	0

1. Bit 2 is LSB for default 10-bit mode.
2. If critical trip lockout bit (bit 7 of configuration register in [Table 9](#)) is set, then this register becomes read-only.
3. Depending on status of the resolution register, bit 1 may display 0.125 °C value.
4. Depending on status of the resolution register, bit 0 may display 0.0625 °C value.

**Note:** *In all temperature register formats bits 0 and bits 1 are used when the resolution is more than 10 bits. These registers show temperature data for the default 10 bits.*

### 4.5 Manufacturer ID register (read-only)

The manufacturer's ID (programmed value 104Ah) in this register is the STMicroelectronics Identification provided by the Peripheral Component Interconnect Special Interest Group (PCiSIG).

**Table 19. Manufacturer ID register (read-only)**

Bit15	Bit14	Bit13	Bit12	Bit11	Bit10	Bit9	Bit8
0	0	0	1	0	0	0	0
Bit7	Bit6	Bit5	Bit4	Bit3	Bit2	Bit1	Bit0
0	1	0	0	1	0	1	0

### 4.6 Device ID and device revision ID register (read-only)

The device IDs and device revision IDs are maintained in this register. The register format is shown in [Table 20](#). The device IDs and device revision IDs are currently '0' and will be incremented whenever an update of the device is made.

**Table 20. Device ID and device revision ID register (read-only)**

Bit15	Bit14	Bit13	Bit12	Bit11	Bit10	Bit9	Bit8
0	0	0	0	0	0	1	1
Device ID							
Bit7	Bit6	Bit5	Bit4	Bit3	Bit2	Bit1	Bit0
0	0	0	0	0	0	0	0
Device revision ID							

The current device ID and revision ID value is 0300 h.

## 4.7 Temperature resolution register (read/write)

With this register a user can program the temperature sensor resolution from 9-12 bits as shown below. The power-on default is always 10 bit (0.25 °C/LSB). The selected resolution is also reflected in bits (4:3) (TRES1:TRES0) of the capability register.

**Table 21. Temperature resolution register (TRES) (read/write)**

Bit7	Bit6	Bit5	Bit4	Bit3	Bit2	Bit1	Bit0
0	0	0	0	0	0	0	1
Resolution section register						Resolution bits	

**Table 22. TRES details**

Resolution register bits				
Bit1	Bit0	°C/LSB	Bits	Conversion time (max)
0	0	0.5	9	65 ms
0	1	0.25	10	125 ms (default)
1	0	0.125	11	250 ms
1	1	0.0625	12	500 ms

The default value is 01 for TRES register.

## 4.8 SMBus timeout

The STTS2002 supports the SMBus timeout feature which is turned on by default. If the host holds SCL low for more than  $t_{\text{timeout}}$  (max), the STTS2002 resets itself and releases the bus. This feature is supported even when the device is in shutdown mode and when the device is driving SDA low.

## 5 SPD EEPROM operation

### 5.1 2 Kb SPD EEPROM operation

The 2 Kb serial EEPROM is able to lock permanently the data in its first half (from location 00h to 7Fh). This feature has been designed specifically for use in DRAM DIMMs (dual in line memory modules) with serial presence detect. All the information concerning the DRAM module configuration (such as its access speed, its size, its organization) can be kept write protected in the first half of the memory.

The first half of the memory area can be write-protected using two different software write protection mechanisms. By sending the device a specific sequence, the first 128 bytes of the memory become write protected: permanently or resettable.

These I<sup>2</sup>C-compatible electrically erasable programmable memory (EEPROM) devices are organized as 256x8 bits.

I<sup>2</sup>C uses a two wire serial interface, comprising a bidirectional data line and a clock line. The device carries a built-in 4-bit device type identifier code (1010) in accordance with the I<sup>2</sup>C bus definition to access the memory area and a second device type identifier code (0110) to define the protection. These codes are used together with the voltage level applied on the three chip enable inputs (A2, A1, A0). These input signals are used to set the value that is to be looked for on the three least significant bits (b3, b2, b1) of the 7-bit device select code. In the end application, A0, A1 and A2 must be directly (not through a pull-up or pull-down resistor) connected to V<sub>DD</sub> or V<sub>SS</sub> to establish the device select code. When these inputs are not connected, an internal pull-down circuitry makes (A0, A1, A2) = (0,0,0).

The A0 input is used to detect the V<sub>HV</sub> voltage, when decoding an SWP or CWP instruction (refer to [Table 23: Device select code](#)).

The device behaves as a slave device in the I<sup>2</sup>C protocol, with all memory operations synchronized by the serial clock. Read and Write operations are initiated by a START condition, generated by the bus master. The START condition is followed by a Device Select Code and R $\bar{W}$  bit (as described in [Table 23: Device select code](#)), terminated by an acknowledge bit.

When writing data to the memory, the memory inserts an acknowledge bit during the 9<sup>th</sup> bit time, following the bus master's 8-bit transmission. When data is read by the bus master, the bus master acknowledges the receipt of the data byte in the same way. Data transfers are terminated by a STOP condition after an Ack for WRITE, and after a NoAck for READ.

### 5.2 Internal device reset - SPD EEPROM

In order to prevent inadvertent Write operations during power-up, a Power On Reset (POR) circuit is included.

At power-up (phase during which V<sub>DD</sub> is lower than V<sub>DDmin</sub> but increases continuously), the device will not respond to any instruction until V<sub>DD</sub> has reached the Power On Reset threshold voltage (this threshold is lower than the minimum V<sub>DD</sub> operating voltage defined in [Table 2: AC characteristics of STTS2002 for SMBus and I<sup>2</sup>C compatibility timings](#)). Once V<sub>DD</sub> has passed the POR threshold, the device is reset.

Prior to selecting the memory and issuing instructions, a valid and stable  $V_{DD}$  voltage must be applied. This voltage must remain stable and valid until the end of the transmission of the instruction and, for a Write instruction, until the completion of the internal write cycle ( $t_W$ ).

At power-down (phase during which  $V_{DD}$  decreases continuously), as soon as  $V_{DD}$  drops from the normal operating voltage below the Power On Reset threshold voltage, the device stops responding to any instruction sent to it.

**Table 23. Device select code**

	Chip enable signals			Device type identifier				Chip enable bits			$R\bar{W}$
				b7 <sup>(1)</sup>	b6	b5	b4	b3	b2	b1	b0
Memory area select code (two arrays) <sup>(2)</sup>	A2	A1	A0	1	0	1	0	A2	A1	A0	$R\bar{W}$
Set write protection (SWP)	$V_{SS}$	$V_{SS}$	$V_{HV}$	0	1	1	0	0	0	1	0
Clear write protection (CWP)	$V_{SS}$	$V_{DD}$	$V_{HV}$					0	1	1	0
Permanently set write protection (PSWP) <sup>(2)</sup>	A2	A1	A0					A2	A1	A0	0
Read SWP	$V_{SS}$	$V_{SS}$	$V_{HV}$					0	0	1	1
Read CWP	$V_{SS}$	$V_{DD}$	$V_{HV}$					0	1	1	1
Read PSWP <sup>(2)</sup>	A2	A1	A0					A2	A1	A0	1

1. The most significant bit, b7, is sent first.

2. A0, A1 and A2 are compared against the respective external pins on the memory device.

### 5.3 Memory addressing

To start communication between the bus master and the slave device, the bus master must initiate a Start condition. Following this, the bus master sends the device select code, shown in [Table 23: Device select code](#) (on serial data (SDA), most significant bit first).

The device select code consists of a 4-bit device type identifier, and a 3-bit chip enable "Address" (A2, A1, A0). To address the memory array, the 4-bit device type identifier is 1010b; to access the write-protection settings, it is 0110b.

Up to eight memory devices can be connected on a single I<sup>2</sup>C bus. Each one is given a unique 3-bit code on the chip enable (A0, A1, A2) inputs. When the device select code is received, the device only responds if the chip enable address is the same as the value on the chip enable (A0, A1, A2) inputs.

The 8<sup>th</sup> bit is the Read/Write bit ( $R\bar{W}$ ). This bit is set to 1 for Read and 0 for Write operations.

If a match occurs on the device select code, the corresponding device gives an acknowledgment on serial data (SDA) during the 9<sup>th</sup> bit time. If the device does not match the device select code, it deselects itself from the bus, and goes into standby mode. The operating modes are detailed in [Table 24](#).

**Table 24. Operating modes**

Mode	R $\overline{W}$ bit	Bytes	Initial sequence
Current address read	1	1	START, device select, R $\overline{W}$ = 1
Random address read	0	1	START, device select, R $\overline{W}$ = 0, address
	1		reSTART, device select, R $\overline{W}$ = 1
Sequential read	1	$\geq 1$	Similar to current or random address read
Byte write	0	1	START, device select, R $\overline{W}$ = 0
Page write	0	$\leq 16$	START, device select, R $\overline{W}$ = 0
TS write	0	2	START, device select, R $\overline{W}$ = 0, pointer data, stop
TS read	1	2	START, device select, R $\overline{W}$ = 1, pointer data, stop

### 5.4 Software write protect

Software write-protection allows the bottom half of the memory area (addresses 00h to 7Fh) to be temporarily or permanently write protected.

Software write-protection is handled by three instructions:

- SWP: set write protection
- CWP: clear write protection
- PSWP: permanently set write protection

The level of write-protection (set or cleared) that has been defined using these instructions, remains defined even after a power cycle.

**Figure 10. Result of setting the write protection**

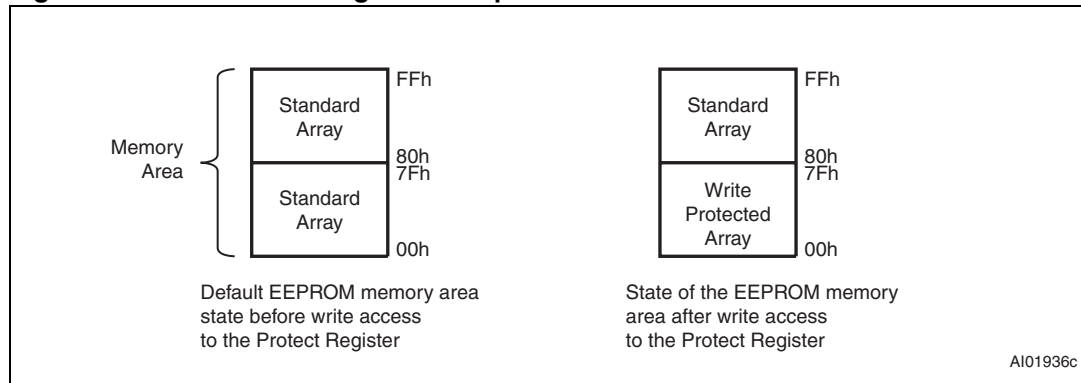



### 5.4.1 SWP and CWP

If the software write-protection has been set with the SWP instruction, it can be cleared again with a CWP instruction.

The two instructions (SWP and CWP) have the same format as a byte write instruction, but with a different device type identifier (as shown in [Table 23](#)). Like the byte write instruction, it is followed by an address byte and a data byte, but in this case the contents are all “Don’t Care” ([Figure 11](#)). Another difference is that the voltage,  $V_{HV}$ , must be applied on the A0 pin, and specific logical levels must be applied on the other two (A1 and A2, as shown in [Table 23](#)).

### 5.4.2 PSWP

If the software write-protection has been set with the PSWP instruction, the first 128 bytes of the memory are permanently write-protected. This write-protection cannot be cleared by any instruction, or by power-cycling the device. Also, once the PSWP instruction has been successfully executed, the STTS2002 SPD no longer acknowledges any instruction (with a device type identifier of 0110) to access the write-protection settings.

**Figure 11. Setting the write protection**

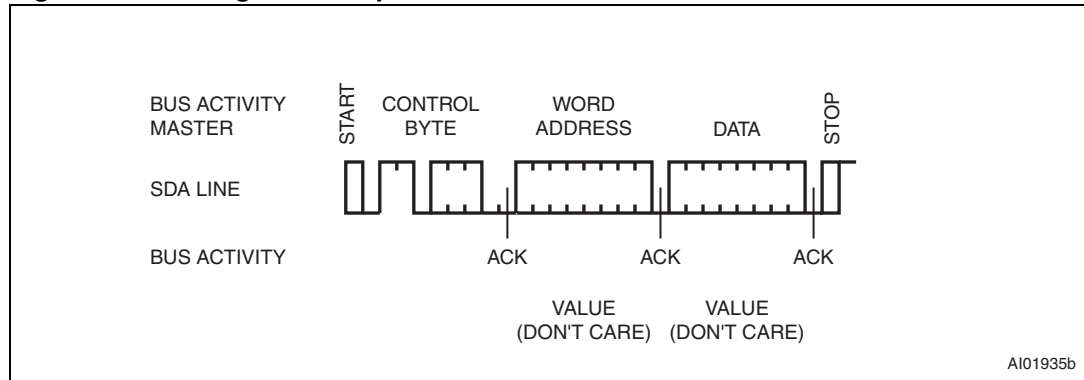

### Reading write-protection status

The status of software write protection can be determined using these instructions:

- Read SWP: Read Write Protection status
- Read PSWP: Read Permanently Set Write Protection status

### Read SWP

The controller issues a Read SWP command. If Software Write Protection has not been set, the device replies to the data byte with an Ack. If Software Write Protection has been set, the device replies to the data byte with a NoAck.

### Read PSWP

The controller issues a Read PSWP command. If Permanent Software Write Protection has not been set, the device replies to the data byte with an Ack. If Permanent Software Write Protection has been set, the device replies to the data byte with a NoAck.

## 5.5 Write operations

Following a start condition the bus master sends a device select code with the  $\overline{RW}$  bit reset to 0. The device acknowledges this, as shown in *Figure 12*, and waits for an address byte. The device responds to the address byte with an acknowledge bit, and then waits for the data byte.

When the bus master generates a stop condition immediately after the ack bit (in the “10<sup>th</sup> bit” time slot), either at the end of a byte write or a page write, the internal memory write cycle is triggered. A stop condition at any other time slot does not trigger the internal write cycle.

During the internal write cycle, serial data (SDA) and serial clock (SCL) are ignored, and the device does not respond to any requests.

### 5.5.1 Byte write

After the device select code and the address byte, the bus master sends one data byte. If the addressed location is hardware write-protected, the device replies to the data byte with NoAck, and the location is not modified. If, instead, the addressed location is not write-protected, the device replies with Ack. The bus master terminates the transfer by generating a stop condition, as shown in *Figure 12*.

### 5.5.2 Page write

The page write mode allows up to 16 bytes to be written in a single write cycle, provided that they are all located in the same page in the memory: that is, the most significant memory address bits are the same. If more bytes are sent than will fit up to the end of the page, a condition known as ‘roll-over’ occurs. This should be avoided, as data starts to become overwritten in an implementation dependent way.

The bus master sends from 1 to 16 bytes of data, each of which is acknowledged by the device. After each byte is transferred, the internal byte address counter (the 4 least significant address bits only) is incremented. The transfer is terminated by the bus master generating a stop condition.

**Figure 12. Write mode sequences in a non write-protected area of SPD**

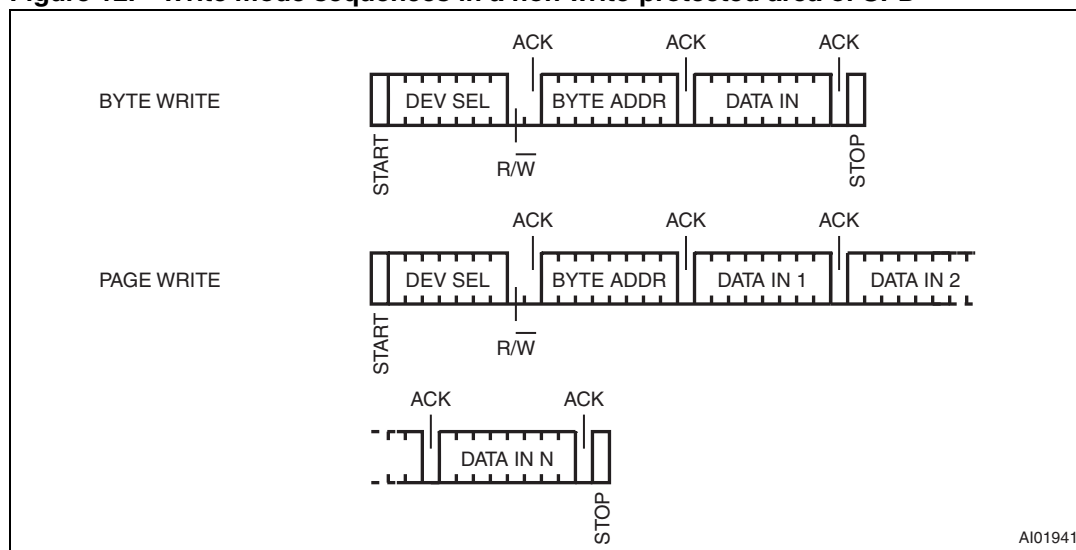

### 5.5.3 Write cycle polling using ACK

During the internal write cycle, the device disconnects itself from the bus and writes a copy of the data from its internal latches to the memory cells. The maximum write time ( $t_w$ ) is shown in *Table 2 on page 15*, but the typical time is shorter. To make use of this, a polling sequence can be used by the bus master.

The sequence, as shown in *Figure 13*, is:

- Initial condition: a write cycle is in progress.
- Step 1: the bus master issues a start condition followed by a device select code (the first byte of the new instruction).
- Step 2: if the device is busy with the internal write cycle, no Ack will be returned and the bus master goes back to step 1. If the device has terminated the internal write cycle, it responds with an Ack, indicating that the device is ready to receive the second part of the instruction (the first byte of this instruction having been sent during step 1).

**Figure 13. Write cycle polling flowchart using ACK**

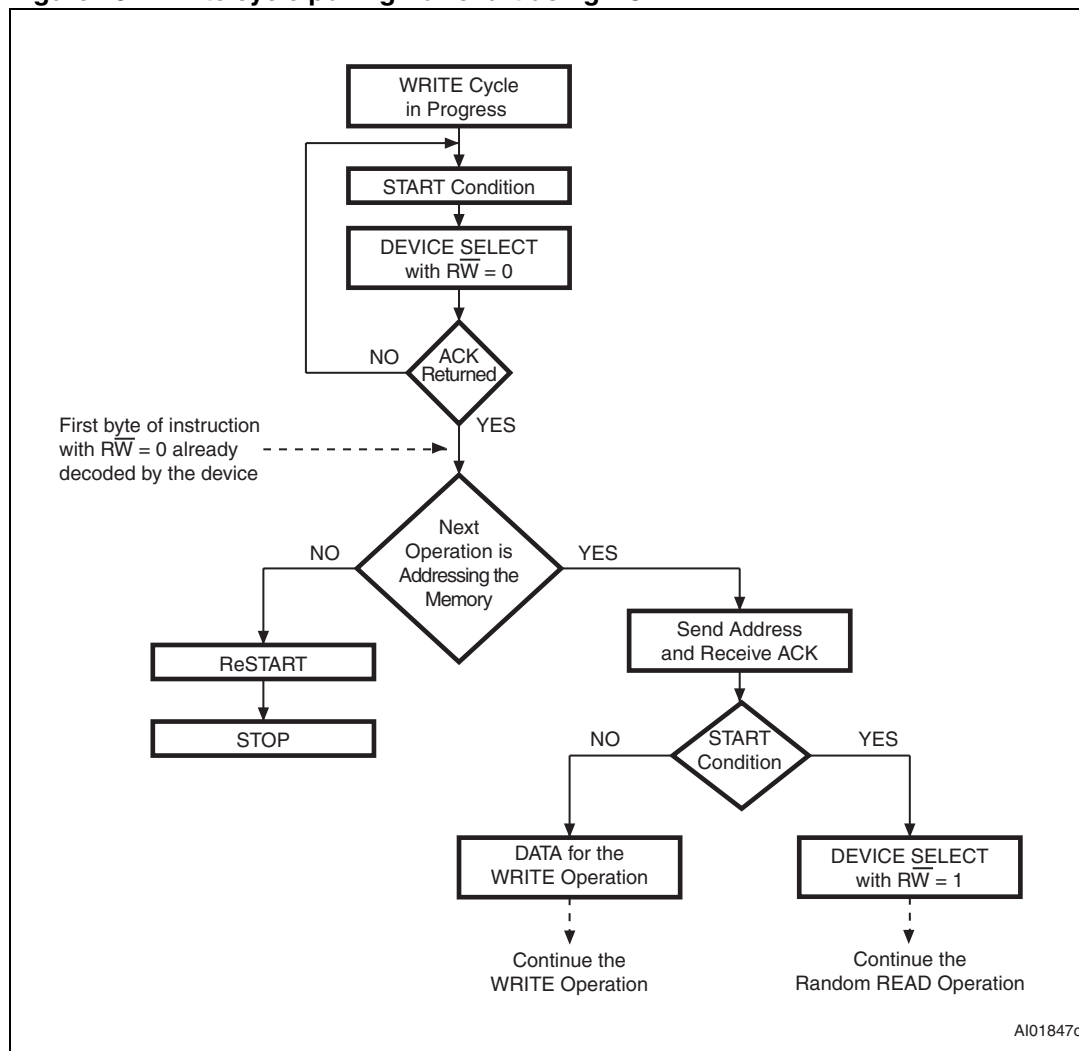

## 5.6 Read operations - SPD

Read operations are performed independently of whether hardware or software protection has been set.

The device has an internal address counter which is incremented each time a byte is read.

**Figure 14. Read mode sequences - SPD**

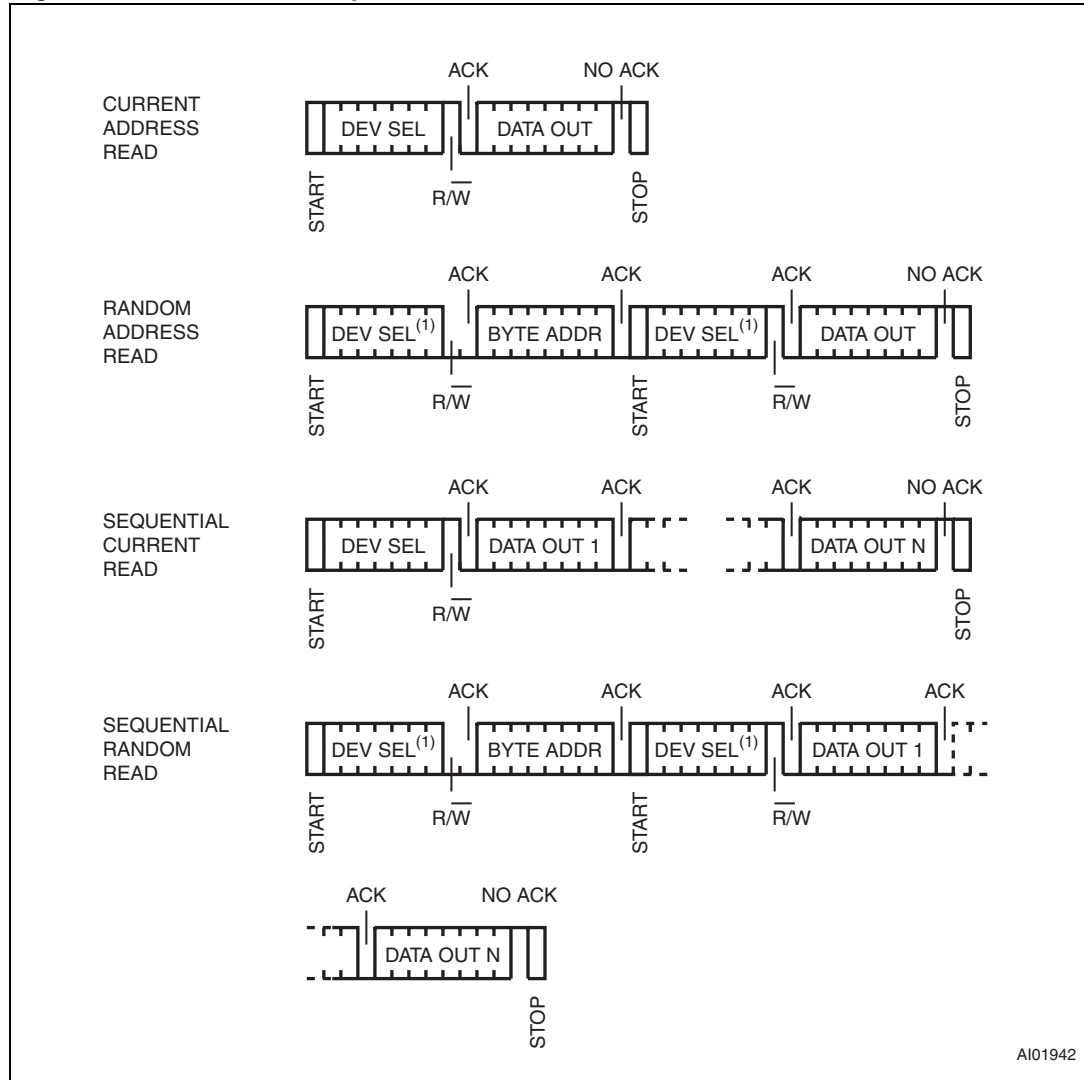

1. The seven most significant bits of the device select code of a random read (in the 1<sup>st</sup> and 3<sup>rd</sup> bytes) must be identical.

### 5.6.1 Random address read - SPD

A dummy write is first performed to load the address into this address counter (as shown in [Figure 14](#)) but *without* sending a stop condition. Then, the bus master sends another start condition, and repeats the device select code, with the  $\overline{R/W}$  bit set to 1. The device acknowledges this, and outputs the contents of the addressed byte. The bus master must *not* acknowledge the byte, and terminates the transfer with a stop condition.

### 5.6.2 Current address read - SPD

For the current address read operation, following a start condition, the bus master only sends a device select code with the  $\overline{RW}$  bit set to 1. The device acknowledges this, and outputs the byte addressed by the internal address counter. The counter is then incremented. The bus master terminates the transfer with a stop condition, as shown in [Figure 14](#), without acknowledging the byte.

### 5.6.3 Sequential read - SPD

This operation can be used after a current address read or a random address read. The bus master *does* acknowledge the data byte output, and sends additional clock pulses so that the device continues to output the next byte in sequence. To terminate the stream of bytes, the bus master must *not* acknowledge the last byte, and *must* generate a stop condition, as shown in [Figure 14](#).

The output data comes from consecutive addresses, with the internal address counter automatically incremented after each byte output. After the last memory address, the address counter 'rolls-over', and the device continues to output data from memory address 00h.

### 5.6.4 Acknowledge in read mode

For all read commands, the device waits, after each byte read, for an acknowledgment during the 9<sup>th</sup> bit time. If the bus master does not drive serial data (SDA) low during this time, the device terminates the data transfer and switches to its standby mode.

[Table 25](#) and [Table 26 on page 38](#) show how the Ack bits can be used to identify the write-protection status.

**Table 25. Acknowledge when writing data or defining the write-protection (instructions with R/W bit = 0)**

Status	Instruction	Ack	Address	Ack	Data byte	Ack	Write cycle( $t_w$ )
Permanently protected	PSWP, SWP or CWP	NoAck	Not significant	NoAck	Not significant	NoAck	No
	Page or byte write in lower 128 bytes	Ack	Address	Ack	Data	NoAck	No
Protected with SWP	SWP	NoAck	Not significant	NoAck	Not significant	NoAck	No
	CWP	Ack	Not significant	Ack	Not significant	Ack	Yes
	PSWP	Ack	Not significant	Ack	Not significant	Ack	Yes
	Page or byte write in lower 128 bytes	Ack	Address	Ack	Data	NoAck	No
Not Protected	PSWP, SWP or CWP	Ack	Not significant	Ack	Not significant	Ack	Yes
	Page or byte write	Ack	Address	Ack	Data	Ack	Yes

**Table 26. Acknowledge when reading the write protection (instructions with  $\overline{R/W}$  bit=1)**

Status	Instruction	Ack	Address	Ack	Data byte	Ack
Permanently protected	PSWP, SWP or CWP	NoAck	Not significant	NoAck	Not significant	NoAck
Protected with SWP	SWP	NoAck	Not significant	NoAck	Not significant	NoAck
	CWP	Ack	Not significant	NoAck	Not significant	NoAck
	PSWP	Ack	Not significant	NoAck	Not significant	NoAck
Not protected	PSWP, SWP or CWP	Ack	Not significant	NoAck	Not significant	NoAck

## 5.7 Initial delivery state - SPD

The device is delivered with all bits in the memory array set to '1' (each byte contains FFh).

## 6 Use in a memory module

In the Dual In line Memory Module (DIMM) application, the SPD is soldered directly on to the printed circuit module. The three chip enable inputs (A0, A1, A2) must be connected to  $V_{SS}$  or  $V_{DD}$  directly (that is without using a pull-up or pull-down resistor) through the DIMM socket (see [Table 27](#)).

**Table 27. DRAM DIMM connections**

DIMM position	A2	A1	A0
0	$V_{SS}$ (0)	$V_{SS}$ (0)	$V_{SS}$ (0)
1	$V_{SS}$ (0)	$V_{SS}$ (0)	$V_{DD}$ (1)
2	$V_{SS}$ (0)	$V_{DD}$ (1)	$V_{SS}$ (0)
3	$V_{SS}$ (0)	$V_{DD}$ (1)	$V_{DD}$ (1)
4	$V_{DD}$ (1)	$V_{SS}$ (0)	$V_{SS}$ (0)
5	$V_{DD}$ (1)	$V_{SS}$ (0)	$V_{DD}$ (1)
6	$V_{DD}$ (1)	$V_{DD}$ (1)	$V_{SS}$ (0)
7	$V_{DD}$ (1)	$V_{DD}$ (1)	$V_{DD}$ (1)

### 6.1 Programming the SPD

The situations in which the SPD EEPROM is programmed can be considered under two headings:

- when the DIMM is isolated (not inserted on the PCB motherboard)
- when the DIMM is inserted on the PCB motherboard

#### 6.1.1 DIMM isolated

With specific programming equipment, it is possible to define the SPD EEPROM content, using byte and page write instructions, and its write-protection using the SWP and CWP instructions. To issue the SWP and CWP instructions, the DIMM must be inserted in the application-specific slot where the A0 signal can be driven to  $V_{HV}$  during the whole instruction. This programming step is mainly intended for use by DIMM makers, whose end application manufacturers will want to clear this write-protection with the CWP on their own specific programming equipment, to modify the lower 128 bytes, and finally to set permanently the write-protection with the PSWP instruction.

#### 6.1.2 DIMM inserted in the application motherboard

As the final application cannot drive the A0 pin to  $V_{HV}$ , the only possible action is to freeze the write-protection with the PSWP instruction.

## 7 Maximum ratings

Stressing the device above the ratings listed in the absolute maximum ratings table may cause permanent damage to the device. These are stress ratings only and operation of the device at these or any other conditions above those indicated in the operating sections of this specification is not implied. Exposure to absolute maximum rating conditions for extended periods may affect device reliability.

**Table 28. Absolute maximum ratings**

Symbol	Parameter	Value	Unit	
$T_{STG}$	Storage temperature	-65 to 150	°C	
$T_{SLD}^{(1)}$	Lead solder temperature for 10 seconds	260	°C	
$V_{IO}$	Input or output voltage	A0	$V_{SS} - 0.3$ to 10.0	V
		others	$V_{SS} - 0.3$ to 6.5	V
$V_{DD}$	Supply voltage	$V_{SS} - 0.3$ to 6.5	V	
$I_O$	Output current	10	mA	
$P_D$	Power dissipation	320	mW	
$\theta_{JA}$	Thermal resistance	87.4	°C/W	

1. Reflow at peak temperature of 260 °C. The time above 255 °C must not exceed 30 seconds.



## 8 DC and AC parameters

This section summarizes the operating measurement conditions, and the dc and ac characteristics of the device. The parameters in the DC and AC characteristics tables that follow, are derived from tests performed under the measurement conditions summarized in [Table 29](#). Designers should check that the operating conditions in their circuit match the operating conditions when relying on the quoted parameters.

**Table 29. Operating and AC measurement conditions**

Parameter	Conditions	Unit
V <sub>DD</sub> supply voltage	2.3 to 3.6	V
Operating temperature	-40 to 125	°C
Input rise and fall times	≤ 50	ns
Load capacitance	100	pf
Input pulse voltages	0.2V <sub>DD</sub> to 0.8V <sub>DD</sub>	V
Input and output timing reference voltages	0.3V <sub>DD</sub> to 0.7V <sub>DD</sub>	V

**Figure 15. AC measurement I/O waveform**

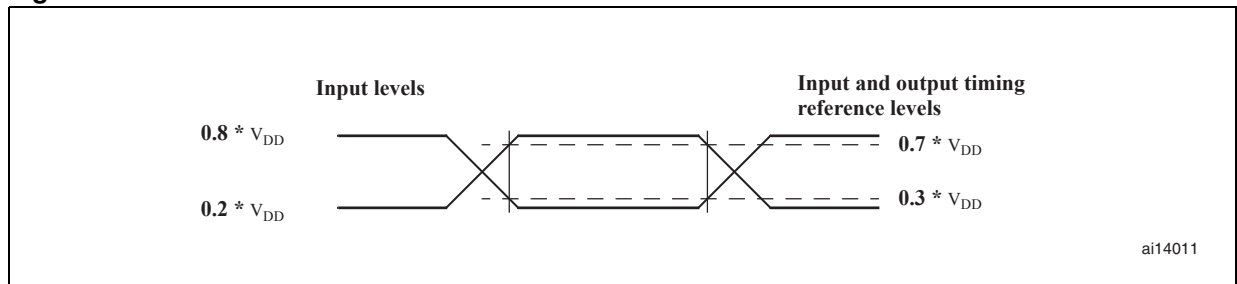

**Table 30. DC/AC characteristics - temperature sensor component with EEPROM**

Sym	Description	Test condition <sup>(1)</sup>	Min	Typ <sup>(2)</sup>	Max	Unit
V <sub>DD</sub>	Supply voltage		2.3	3.3	3.6	V
I <sub>DD</sub>	V <sub>DD</sub> supply current (no load)	EEPROM active <sup>(3)</sup> F = 400 kHz		0.4	2.0	mA
		EEPROM standby, F = 400 kHz		160	300	µA
I <sub>DD1</sub>	Shutdown mode supply current	EEPROM standby, TS shutdown		3.0	5	µA
I <sub>ILI</sub>	Input leakage current (SCL, SDA)	V <sub>IN</sub> = V <sub>SS</sub> or V <sub>DD</sub>			±5	µA
I <sub>ILO</sub>	Output leakage current	V <sub>OUT</sub> = V <sub>SS</sub> or V <sub>DD</sub> , SDA in Hi-Z			±5	µA
V <sub>POR</sub>	Power on Reset (POR) threshold	V <sub>DD</sub> falling edge: DN package		1.75		V

**Table 30. DC/AC characteristics - temperature sensor component with EEPROM (continued)**

Sym	Description	Test condition <sup>(1)</sup>	Min	Typ <sup>(2)</sup>	Max	Unit
B-grade	Accuracy for corresponding range 2.3 V ≤ V <sub>DD</sub> ≤ 3.6 V	+75 °C < T <sub>A</sub> < +95		±0.5	±1.0	°C
		+40 °C < T <sub>A</sub> < +125		±1.0	±2.0	°C
		-40 °C < T <sub>A</sub> < +125		±2.0	±3.0	°C
	Resolution		0.5	0.25	0.0625	°C/LSB
			9	10	12	bits
t <sub>CONV</sub>	Conversion time	10-bit - default			125	ms
<b>SMBus/I<sup>2</sup>C interface</b>						
V <sub>IH</sub>	Input logic high	SCL, SDA, A0-A2	0.7V <sub>DD</sub>		V <sub>DD</sub> + 1	V
V <sub>IL</sub>	Input logic low	SCL, SDA, A0-A2	-0.5		0.3V <sub>DD</sub>	V
C <sub>IN</sub> <sup>(4)</sup>	SMBus/I <sup>2</sup> C input capacitance			5		pF
f <sub>SCL</sub>	SMBus/I <sup>2</sup> C clock frequency		10		400	kHz
t <sub>timeout</sub>	SMBus timeout	Temperature sensor only	25		35	ms
V <sub>HV</sub>	A0 high voltage	V <sub>HV</sub> ≥ V <sub>DD</sub> + 4.8 V	7		10	V
V <sub>OL1</sub>	Low level voltage, $\overline{\text{EVENT}}$	I <sub>OL</sub> = 2.1 mA			0.4	V
V <sub>OL2</sub>	Low level voltage, SDA	I <sub>OL</sub> = 2.1 mA			0.4	V
		I <sub>OL</sub> = 6 mA			0.6	V
Z <sub>AIL</sub> <sup>(4)</sup>	(A0, A1, A2) input impedance	V <sub>IN</sub> < 0.3 V <sub>DD</sub>	30			kΩ
Z <sub>AIH</sub> <sup>(4)</sup>	(A0, A1, A2) input Impedance	V <sub>IN</sub> > 0.7 V <sub>DD</sub>	800			kΩ
t <sub>SP</sub> <sup>(4)</sup>	Spike suppression Pulse width of spikes that must be suppressed by the input filter	Input filter on SCL and SDA			50	ns
V <sub>HYST</sub> <sup>(5)</sup>	Input hysteresis (SCL, SDA)	TS only	0.05V <sub>DD</sub>			V

1. Guaranteed operating temperature for combined module: T<sub>A</sub> = -40 °C to 125 °C; V<sub>DD</sub> = 2.3 V to 3.6 V (except where noted).
2. Typical numbers taken at V<sub>DD</sub> = 3.3 V, T<sub>A</sub> = 25 °C.
3. Read current only
4. Verified by design and characterization, not necessarily tested on all devices
5. V<sub>HYST</sub> parameter is optional in the JEDEC TSE2002a2 specifications

## 9 Package mechanical data

In order to meet environmental requirements, ST offers these devices in different grades of ECOPACK<sup>®</sup> packages, depending on their level of environmental compliance. ECOPACK<sup>®</sup> specifications, grade definitions and product status are available at: [www.st.com](http://www.st.com). ECOPACK<sup>®</sup> is an ST trademark.

Figure 16. TDFN8 – 8-lead thin dual flat, no-lead (2 mm x 3 mm) package outline (DN)

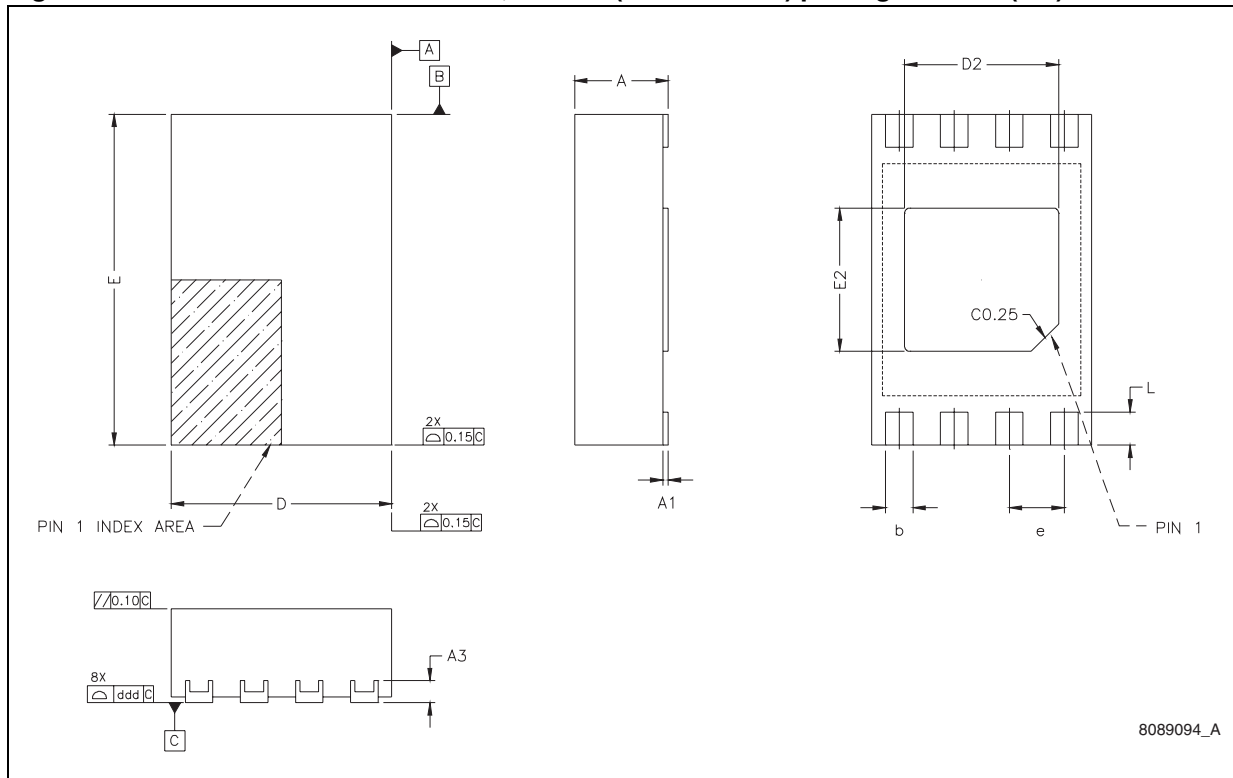

Note: JEDEC MO-229, variation WCED-3 proposal

Table 31. TDFN8 – 8-lead thin dual flat, no-lead (2 mm x 3 mm) mechanical data (DN)

Sym	mm			inches		
	Min	Typ	Max	Min	Typ	Max
A	0.70	0.75	0.80	0.028	0.030	0.031
A1	0.00	0.00	0.05	0.000	0.000	0.002
A3		0.20			0.008	
b	0.20	0.25	0.30	0.008	0.010	0.012
D	1.95	2.00	2.05	0.077	0.079	0.081
D2	1.35	1.40	1.45	0.053	0.055	0.057
E	2.95	3.00	3.05	0.116	0.118	0.120
E2	1.25	1.30	1.35	0.049	0.051	0.053
e		0.50			0.020	
L	0.30	0.35	0.40	0.012	0.014	0.016
ddd			0.08			0.003

Note: JEDEC MO-229, variation WCED-3 proposal

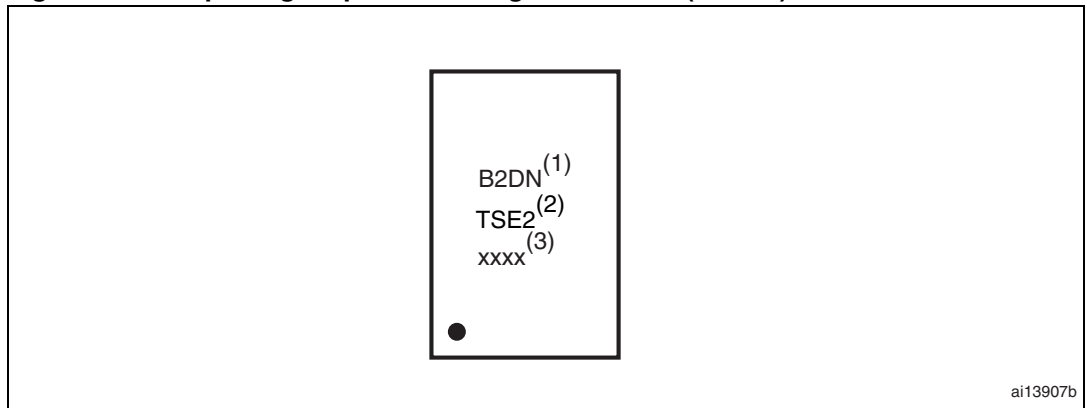
**Figure 17. DN package topside marking information (TDFN8)**

1. Temperature grade and package  
B = B-grade, stacked  
2 = Minimum operating voltage of 2.3 V  
DN = 0.80 mm TDFN package
2. Device name  
TSE2 = STTS2002
3. Traceability codes

The landing pattern recommendations per the JEDEC proposal for the TDFN package (DN) are shown in [Figure 18](#).

The preferred implementation with wide corner pads enhances device centering during assembly, but a narrower option is defined for modules with tight routing requirements.

**Figure 18. Landing pattern - TDFN8 package (DN)**

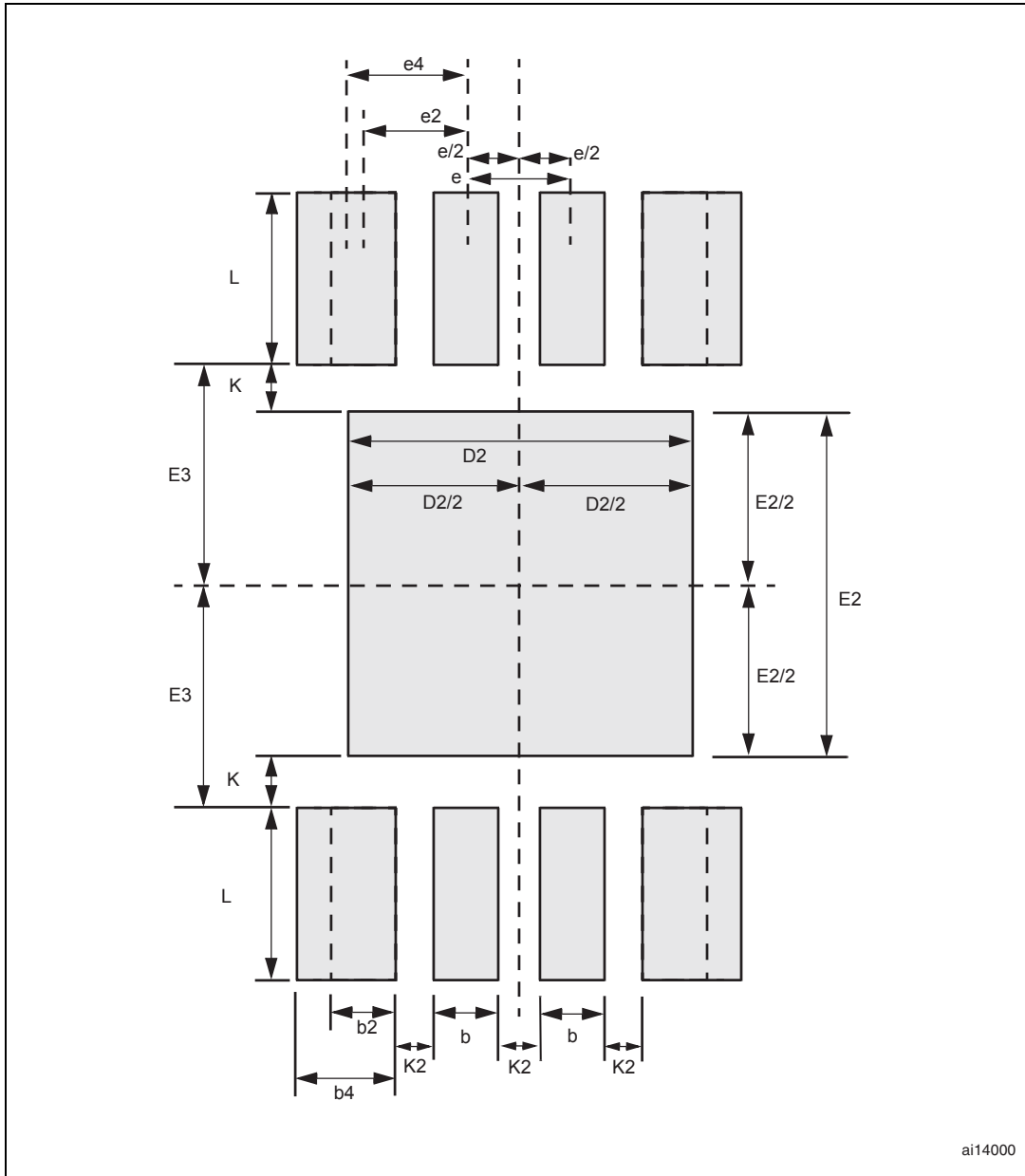

ai14000

Table 32 lists variations of landing pattern implementations, ranked as “Preferred” and Minimum Acceptable” based on the JEDEC proposal.

**Table 32. Parameters for landing pattern - TDFN8 package (DN)**

Parameter	Description	Dimension		
		Min	Nom	Max
D2	Heat paddle width	1.40	-	1.60
E2	Heat paddle height	1.40	-	1.60
E3	Heat paddle centerline to contact inner locus	1.00	-	-
L	Contact length	0.70	-	0.80
K	Heat paddle to contact keepout	0.20	-	-
K2	Contact to contact keepout	0.20	-	-
e	Contact centerline to contact centerline pitch for inner contacts	-	0.50	-
b	Contact width for inner contacts	0.25	-	0.30
e2	Landing pattern centerline to outer contact centerline, “minimum acceptable” option <sup>(1)</sup>	-	0.50	-
b2	Corner contact width, “minimum acceptable option” <sup>(1)</sup>	0.25	-	0.30
e4	Landing pattern centerline to outer contact centerline, “preferred” option <sup>(2)</sup>	-	0.60	-
b4	Corner contact width, “preferred” option <sup>(2)</sup>	0.45	-	0.50

1. Minimum acceptable option to be used when routing prevents preferred width contact.

2. Preferred option to be used when possible.

Figure 19. Carrier tape for TDFN8 package

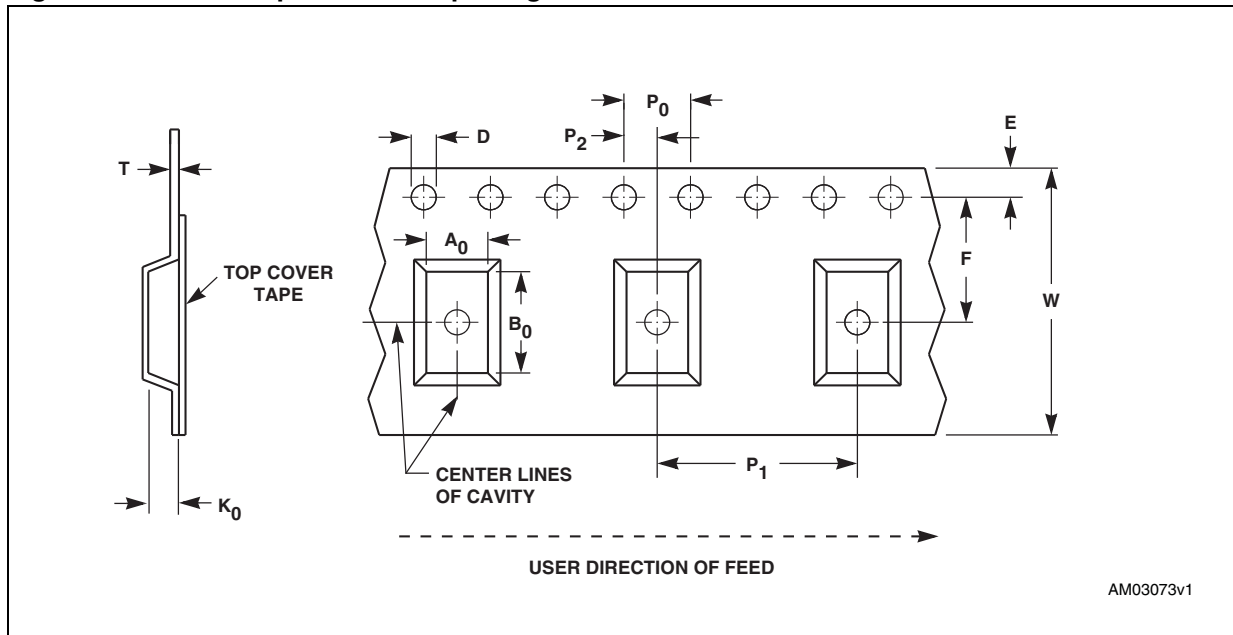
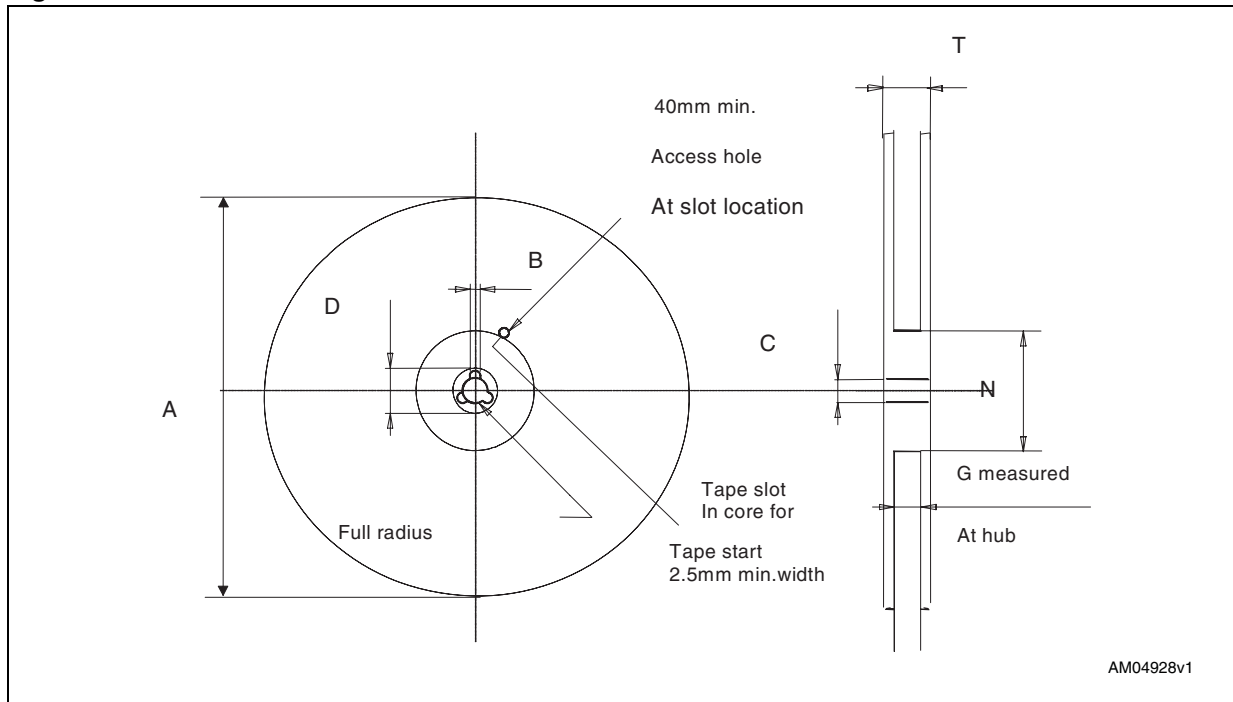

Table 33. Carrier tape dimensions TDFN8 package

Package	W	D	E	P <sub>0</sub>	P <sub>2</sub>	F	A <sub>0</sub>	B <sub>0</sub>	K <sub>0</sub>	P <sub>1</sub>	T	Unit	Bulk Qty
TDFN8	8.00 +0.30 -0.10	1.50 +0.10/ -0.00	1.75 ±0.10	4.00 ±0.10	2.00 ±0.10	3.50 ±0.05	2.30 ±0.10	3.20 ±0.10	1.10 ±0.10	4.00 ±0.10	0.30 ±0.05	mm	3000



Figure 20. Reel schematic



AM04928v1

Table 34. Reel dimensions for 8 mm carrier tape - TDFN8 package

A (max)	B (min)	C	D (min)	N (min)	G	T (max)
180 mm (7-inch)	1.5 mm	13 mm ± 0.2 mm	20.2 mm	60 mm	8.4 mm + 2/-0 mm	14.4 mm

Note: The dimensions given in [Table 34](#) incorporate tolerances that cover all variations on critical parameters.

# 10 Part numbering

**Table 35. Ordering information scheme**

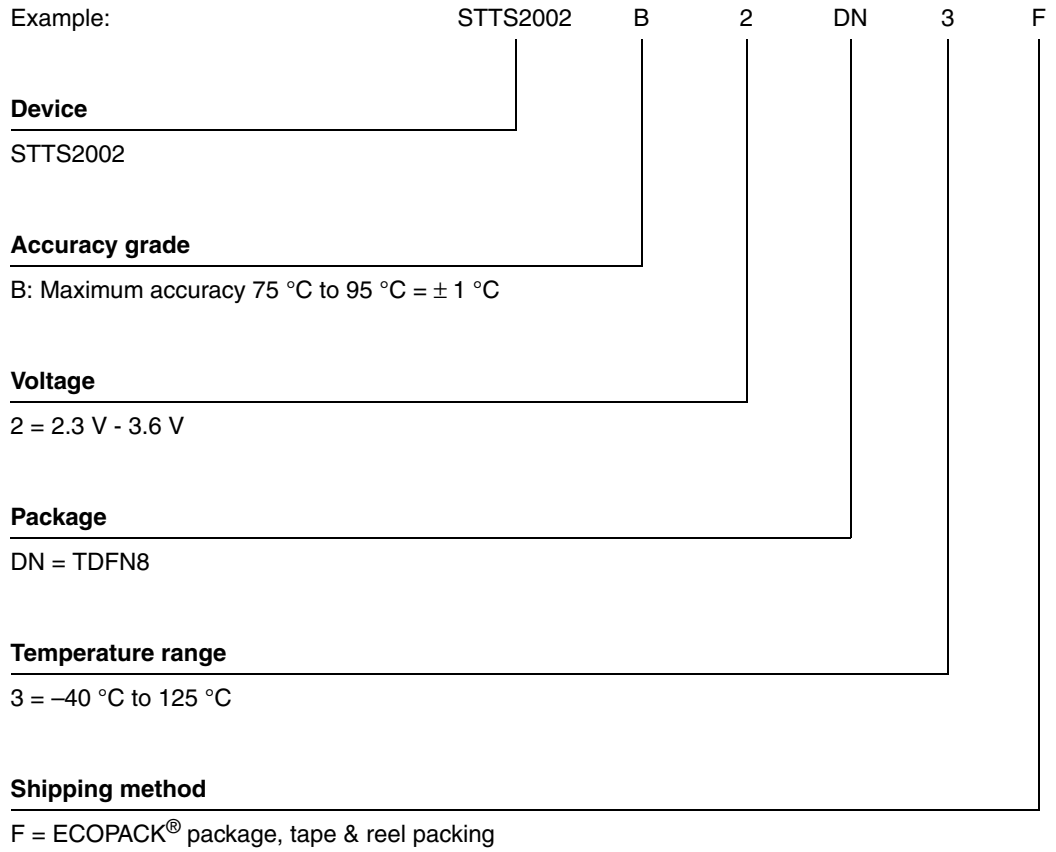

For other options, or for more information on any aspect of this device, please contact the ST sales office nearest you.

# 11 Revision history

**Table 36. Document revision history**

Date	Revision	Changes
11-Feb-2009	1	Initial release.
08-Oct-2009	2	Updated <i>Features</i> , <i>Section 1</i> , <i>Section 2.1</i> , <i>Section 2.2.5</i> , <i>Section 3.3</i> , <i>Section 4.1</i> , <i>Section 4.8</i> , <i>Section 5.4</i> , <i>Section 5.4.2</i> , <i>Section 5.5.2</i> , <i>Section 5.5.3</i> , <i>Section 6</i> , <i>Figure 3</i> , <i>7</i> , <i>19</i> , <i>Table 2</i> , <i>3</i> , <i>5</i> , <i>6</i> , <i>7</i> , <i>9</i> , <i>12</i> , <i>13</i> , <i>24</i> , <i>25</i> , <i>28</i> , <i>29</i> , and <i>30</i> ; moved <i>Figure 14</i> , <i>Section 5.7</i> , <i>Table 25</i> and <i>26</i> ; added <i>Table 33</i> ; removed section on “Alert reponse address (ARA)”; reformatted document.
19-Oct-2009	3	Updated <i>Figure 17</i> .
13-Sep-2010	4	Document updated to full datasheet; updated <i>Figure 3</i> , <i>Table 35</i> ; <i>Section 4.8: SMBus timeout</i> ; minor textual changes; added <i>Figure 20</i> , <i>Table 34</i> , note to <i>Table 3</i> .
21-Mar-2011	5	Updated <i>Figure 17: DN package topside marking information (TDFN8)</i> and document status.

**Please Read Carefully:**

Information in this document is provided solely in connection with ST products. STMicroelectronics NV and its subsidiaries ("ST") reserve the right to make changes, corrections, modifications or improvements, to this document, and the products and services described herein at any time, without notice.

All ST products are sold pursuant to ST's terms and conditions of sale.

Purchasers are solely responsible for the choice, selection and use of the ST products and services described herein, and ST assumes no liability whatsoever relating to the choice, selection or use of the ST products and services described herein.

No license, express or implied, by estoppel or otherwise, to any intellectual property rights is granted under this document. If any part of this document refers to any third party products or services it shall not be deemed a license grant by ST for the use of such third party products or services, or any intellectual property contained therein or considered as a warranty covering the use in any manner whatsoever of such third party products or services or any intellectual property contained therein.

**UNLESS OTHERWISE SET FORTH IN ST'S TERMS AND CONDITIONS OF SALE ST DISCLAIMS ANY EXPRESS OR IMPLIED WARRANTY WITH RESPECT TO THE USE AND/OR SALE OF ST PRODUCTS INCLUDING WITHOUT LIMITATION IMPLIED WARRANTIES OF MERCHANTABILITY, FITNESS FOR A PARTICULAR PURPOSE (AND THEIR EQUIVALENTS UNDER THE LAWS OF ANY JURISDICTION), OR INFRINGEMENT OF ANY PATENT, COPYRIGHT OR OTHER INTELLECTUAL PROPERTY RIGHT.**

**UNLESS EXPRESSLY APPROVED IN WRITING BY AN AUTHORIZED ST REPRESENTATIVE, ST PRODUCTS ARE NOT RECOMMENDED, AUTHORIZED OR WARRANTED FOR USE IN MILITARY, AIR CRAFT, SPACE, LIFE SAVING, OR LIFE SUSTAINING APPLICATIONS, NOR IN PRODUCTS OR SYSTEMS WHERE FAILURE OR MALFUNCTION MAY RESULT IN PERSONAL INJURY, DEATH, OR SEVERE PROPERTY OR ENVIRONMENTAL DAMAGE. ST PRODUCTS WHICH ARE NOT SPECIFIED AS "AUTOMOTIVE GRADE" MAY ONLY BE USED IN AUTOMOTIVE APPLICATIONS AT USER'S OWN RISK.**

Resale of ST products with provisions different from the statements and/or technical features set forth in this document shall immediately void any warranty granted by ST for the ST product or service described herein and shall not create or extend in any manner whatsoever, any liability of ST.

ST and the ST logo are trademarks or registered trademarks of ST in various countries.

Information in this document supersedes and replaces all information previously supplied.

The ST logo is a registered trademark of STMicroelectronics. All other names are the property of their respective owners.

© 2011 STMicroelectronics - All rights reserved

STMicroelectronics group of companies

Australia - Belgium - Brazil - Canada - China - Czech Republic - Finland - France - Germany - Hong Kong - India - Israel - Italy - Japan - Malaysia - Malta - Morocco - Philippines - Singapore - Spain - Sweden - Switzerland - United Kingdom - United States of America

[www.st.com](http://www.st.com)