



STR71xF

ARM7TDMI™ 32-bit MCU with Flash, USB, CAN
5 timers, ADC, 10 communications interfaces

Features

■ Core

- ARM7TDMI 32-bit RISC CPU
- 59 MIPS @ 66 MHz from SRAM
- 45 MIPS @ 50 MHz from Flash

■ Memories

- Up to 256 Kbytes Flash program memory (10 kcycles endurance, 20 yrs retention @ 85° C)
- 16K bytes Flash data memory (100 kcycles endurance, 20 yrs retention @ 85° C)
- Up to 64 Kbytes RAM
- External Memory Interface (EMI) for up to 4 banks of SRAM, Flash, ROM
- Multi-boot capability

■ Clock, Reset and Supply Management

- 3.0 to 3.6V application supply and I/Os
- Internal 1.8V regulator for core supply
- Clock input from 0 to 16.5 MHz
- Embedded RTC osc. running from external 32 kHz crystal
- Embedded PLL for CPU clock
- Realtime Clock for clock-calendar function
- 5 power saving modes: SLOW, WAIT, LPWAIT, STOP and STANDBY modes

■ Nested interrupt controller

- Fast interrupt handling with multiple vectors
- 32 vectors with 16 IRQ priority levels
- 2 maskable FIQ sources

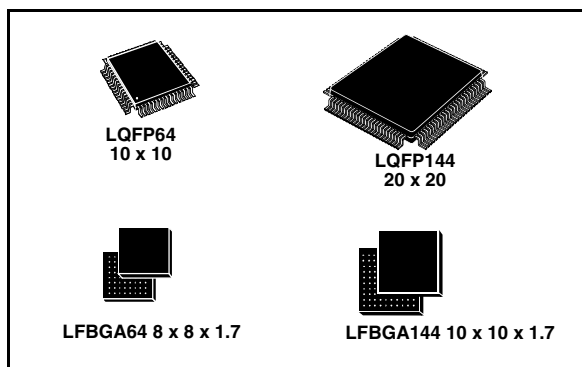

■ Up to 48 I/O ports

- 30/32/48 multifunctional bidirectional I/Os
- Up to 14 ports with interrupt capability

■ 5 Timers

- 16-bit watchdog timer
- 3 16-bit timers with 2 input captures, 2 output compares, PWM and pulse counter
- 16-bit timer for timebase functions

■ 10 Communications Interfaces

- 2 I²C interfaces (1 multiplexed with SPI)
- 4 UART asynchronous serial interfaces
- Smart Card ISO7816-3 interface on UART1
- 2 BSPI synchronous serial interfaces
- CAN interface (2.0B Active)
- USB Full Speed (12Mbit/s) Device Function with Suspend and Resume
- HDLC synchronous communications

■ 4-channel 12-bit A/D Converter

- Sampling frequency up to 1kHz
- Conversion range: 0 to 2.5V

■ Development tools support

Contents

- 1 Introduction 4**
- 2 Device summary 4**
- 3 Description 5**
- 4 System architecture 6**
 - 4.1 On-chip peripherals 7
 - 4.2 Related documentation 10
 - 4.3 Pin description for 144-pin packages 11
 - 4.4 Pin description for 64-pin packages 21
 - 4.5 External connections 28
 - 4.6 I/O port configuration 29
 - 4.7 Memory mapping 30
- 5 Electrical parameters 33**
 - 5.1 Parameter conditions 33
 - 5.1.1 Minimum and maximum values 33
 - 5.1.2 Typical values 33
 - 5.1.3 Typical curves 33
 - 5.1.4 Loading capacitor 33
 - 5.1.5 Pin input voltage 33
 - 5.2 Absolute maximum ratings 34
 - 5.3 Operating conditions 36
 - 5.3.1 Supply current characteristics 37
 - 5.3.2 Clock and timing characteristics 41
 - 5.3.3 Memory characteristics 46
 - 5.3.4 EMC characteristics 47
 - 5.3.5 I/O port pin characteristics 50
 - 5.3.6 TIM timer characteristics 55
 - 5.3.7 EMI - External Memory Interface 56
 - 5.3.8 Communications interfaces 61
 - 5.3.9 ADC characteristics 65

6	Package characteristics	68
6.1	Package mechanical data	68
6.2	Thermal characteristics	71
7	Product history	72
8	Order codes	74
9	Revision history	75

Note: For detailed information on the STR710 Microcontroller memory, registers and peripherals, please refer to the STR710 Reference Manual.

1 Introduction

This datasheet provides the STR71x Ordering Information, Mechanical and Electrical Device Characteristics.

For complete information on the STR710 Microcontroller memory, registers and peripherals, please refer to the STR710 Reference Manual.

For information on programming, erasing and protection of the internal Flash memory please refer to the STR7 Flash Programming Reference Manual

For information on the ARM7TDMI core please refer to the ARM7TDMI Technical Reference Manual

2 Device summary

Table 1. Device summary

Features	STR710 FZ1	STR710 FZ2	STR710 RZ	STR711 FR0	STR711 FR1	STR711 FR2	STR712 FR0	STR712 FR1	STR712 FR2	STR715 FRx
Flash - Kbytes	128+16	256+16	0	64+16	128+16	256+16	64+16	128+16	256+16	64+16
RAM - Kbytes	32	64	64	16	32	64	16	32	64	16
Peripheral Functions	CAN, EMI, USB, 48 I/Os			USB, 30 I/Os			CAN, 32 I/Os			32 I/Os
Operating Voltage	3.0 to 3.6V									
Operating Temp.	-40 to +85°C or 0 to 70° C									
Packages	T=LQFP144 20 x 20 H=LFBGA144 10 x10			T=LQFP64 10 x10 / H=LFBGA64 8 x 8 x 1.7						



3 Description

ARM® core with embedded Flash & RAM

The STR710 series is a family of ARM-powered 32-bit Microcontrollers with embedded Flash and RAM. It combines the high performance ARM7TDMI CPU with an extensive range of peripheral functions and enhanced I/O capabilities. STR71xF devices have on-chip high-speed single voltage FLASH memory and high-speed RAM. STR710R devices have high-speed RAM but no internal Flash. The STR710 family has an embedded ARM core and is therefore compatible with all ARM tools and software.

Extensive tools support

STMicroelectronics' 32-bit, ARM core-based microcontrollers are supported by a complete range of high-end and low-cost development tools to meet the needs of application developers. This extensive line of hardware/software tools includes starter kits and complete development packages all tailored for ST's ARM core-based MCUs. The range of development packages includes third-party solutions that come complete with a graphical development environment and an in-circuit emulator/programmer featuring a JTAG application interface. These support a range of embedded operating systems (OS), while several royalty-free OSs are also available.

For more information, please refer to ST MCU site <http://www.st.com/mcu>

4 System architecture

Package Choice: Low Pin-Count 64-pin or Feature-Rich 144-pin LQFP or BGA

The STR710 family is available in 5 main versions.

The 144-pin versions have the full set of all features including CAN, USB and External Memory Interface (EMI).

- **STR710F:** 144-pin BGA or LQFP with CAN, USB and EMI
- **STR710R:** Flashless 144-pin BGA or LQFP with CAN, USB and EMI (no internal Flash memory)

The three 64-pin versions (BGA or LQFP) do not include External Memory Interface.

- **STR715F:** 64-pin BGA or LQFP without CAN or USB
- **STR711F:** 64-pin BGA or LQFP with USB
- **STR712F:** 64-pin BGA or LQFP with CAN

High Speed Flash Memory (STR71xF)

The Flash program memory is organized in two banks of 32-bit wide Burst Flash memories enabling true read-while-write (RWW) operation. Device Bank 0 is up to 256 Kbytes in size, typically for the application program code. Bank 1 is 16K bytes, typically used for storing data constants. Both banks are accessed by the CPU with zero wait states @ 33 MHz

Bank 0 memory endurance is 10K write/erase cycles and Bank 1 endurance is 100K write/erase cycles. Data retention is 20 years at 85°C on both banks. The two banks can be accessed independently in read or write. Flash memory can be accessed in two modes:

- Burst mode: 64-bit wide memory access at up to 50 MHz.
- Direct 32-bit wide memory access for deterministic operation at up to 33 MHz.

The STR7 embedded Flash memory can be programmed using In-Circuit Programming or In-Application programming.

IAP (In-Application Programming): The IAP is the ability to re-program the Flash memory of a microcontroller while the user program is running.

ICP (In-Circuit Programming): The ICP is the ability to program the Flash memory of a microcontroller using JTAG protocol while the device is mounted on the user application board.

The Flash memory can be protected against different types of unwanted access (read/write/erase). There are two types of protection:

- Sector Write Protection
- Flash Debug Protection (locks JTAG access)

Refer to the STR7 Flash Programming Reference manual for details.

Optional External Memory (STR710)

The non-multiplexed 16-bit data/24-bit address bus available on the STR710 (144-pin) supports four 16-Mbyte banks of external memory. Wait states are programmable individually for each bank allowing different memory types (Flash, EPROM, ROM, SRAM etc.) to be used to store programs or data.

Figure 1 shows the general block diagram of the device family.

Flexible Power Management

To minimize power consumption, you can program the STR710 to switch to SLOW, WAIT, LPWAIT (low power wait), STOP or STANDBY mode depending on the current system activity in the application.

Flexible Clock Control

Two external clock sources can be used, a main clock and a 32 kHz backup clock. The embedded PLL allows the internal system clock (up to 66 MHz) to be generated from a main clock frequency of 16 MHz or less. The PLL output frequency can be programmed using a wide selection of multipliers and dividers. The microcontroller core, APB1 and APB2 peripherals are in separate clock domains and can be programmed to run at different frequencies during application runtime. The clock to each peripheral is gated with an individual control bit to optimize power usage by turning off peripherals any time they are not required.

Voltage Regulators

The STR710 requires an external 3.0-3.6V power supply. There are two internal Voltage Regulators for generating the 1.8V power supply for the core and peripherals. The main VR is switched off during low power operation.

Low Voltage Detectors

Both the Main Voltage Regulator and the Low Power Voltage Regulator contain each a low voltage detection circuitry which keep the device under reset when the corresponding controlled voltage value (V_{18} or V_{18BKP}) falls below 1.35V (+/- 10%). This enhances the security of the system by preventing the MCU from going into an unpredictable state.

An external reset circuit must be used to provide the RESET at V_{33} power-up. It is not sufficient to rely on the RESET generated by the LVD in this case. This is because LVD operation is guaranteed only when V_{33} is within the specification.

4.1 On-chip peripherals

CAN Interface (STR710 and STR712)

The CAN module is compliant with the CAN specification V2.0 part B (active). The bit rate can be programmed up to 1 MBaud.

USB Interface (STR710 and STR711)

The full-speed USB interface is USB V2.0 compliant and provides up to 16 bidirectional/32 unidirectional endpoints, up to 12 Mb/s (full-speed), support for bulk transfer, isochronous transfers and USB Suspend/Resume functions.

Standard Timers

Each of the four timers have a 16-bit free-running counter with 7-bit prescaler

Three timers each provide up to two input capture/output compare functions, a pulse counter function, and a PWM channel with selectable frequency.

The fourth timer is not connected to the I/O ports. It can be used by the application software for general timing functions.

Realtime Clock (RTC)

The RTC provides a set of continuously running counters driven by the 32 kHz external crystal. The RTC can be used as a general timebase or clock/calendar/alarm function. When the STR710 is in Standby mode the RTC can be kept running, powered by the low power voltage regulator and driven by the 32 kHz external crystal.

UARTs

The 4 UARTs allow full duplex, asynchronous, communications with external devices with independently programmable TX and RX baud rates up to 1.25 Mb/s.

Smart Card Interface

UART1 is configurable to function either as a general purpose UART or as an asynchronous Smart Card interface as defined by ISO 7816-3. It includes Smart Card clock generation and provides support features for synchronous cards.

Buffered Serial Peripheral Interfaces (BSPI)

Each of the two SPIs allow full duplex, synchronous communications with external devices, master or slave communication at up to 5.5Mb/s in Master mode and 4 Mb/s in Slave mode.

I²C Interfaces

The two I²C Interfaces provide multi-master and slave functions, support normal and fast I²C mode (400 kHz) and 7 or 10-bit addressing modes.

One I²C Interface is multiplexed with one SPI, so either 2xSPI+1x I²C or 1xSPI+2x I²C may be used at a time.

HDLC interface

The High Level Data Link Controller (HDLC) unit supports full duplex operation and NRZ, NRZI, FM0 or MANCHESTER protocols. It has an internal 8-bit baud rate generator.

A/D Converter

The Analog to Digital Converter, converts in single channel or up to 4 channels in single-shot or round robin mode. Resolution is 12-bit with a sampling frequency of up to 1 kHz. The input voltage range is 0-2.5V.

Watchdog

The 16-bit Watchdog Timer protects the application against hardware or software failures and ensures recovery by generating a reset.

I/O Ports

The 48 I/O ports are programmable as Inputs or Outputs.

External Interrupts

Up to 14 external interrupts are available for application use or to wake-up the application from STOP mode.

Figure 1. STR710 block diagram

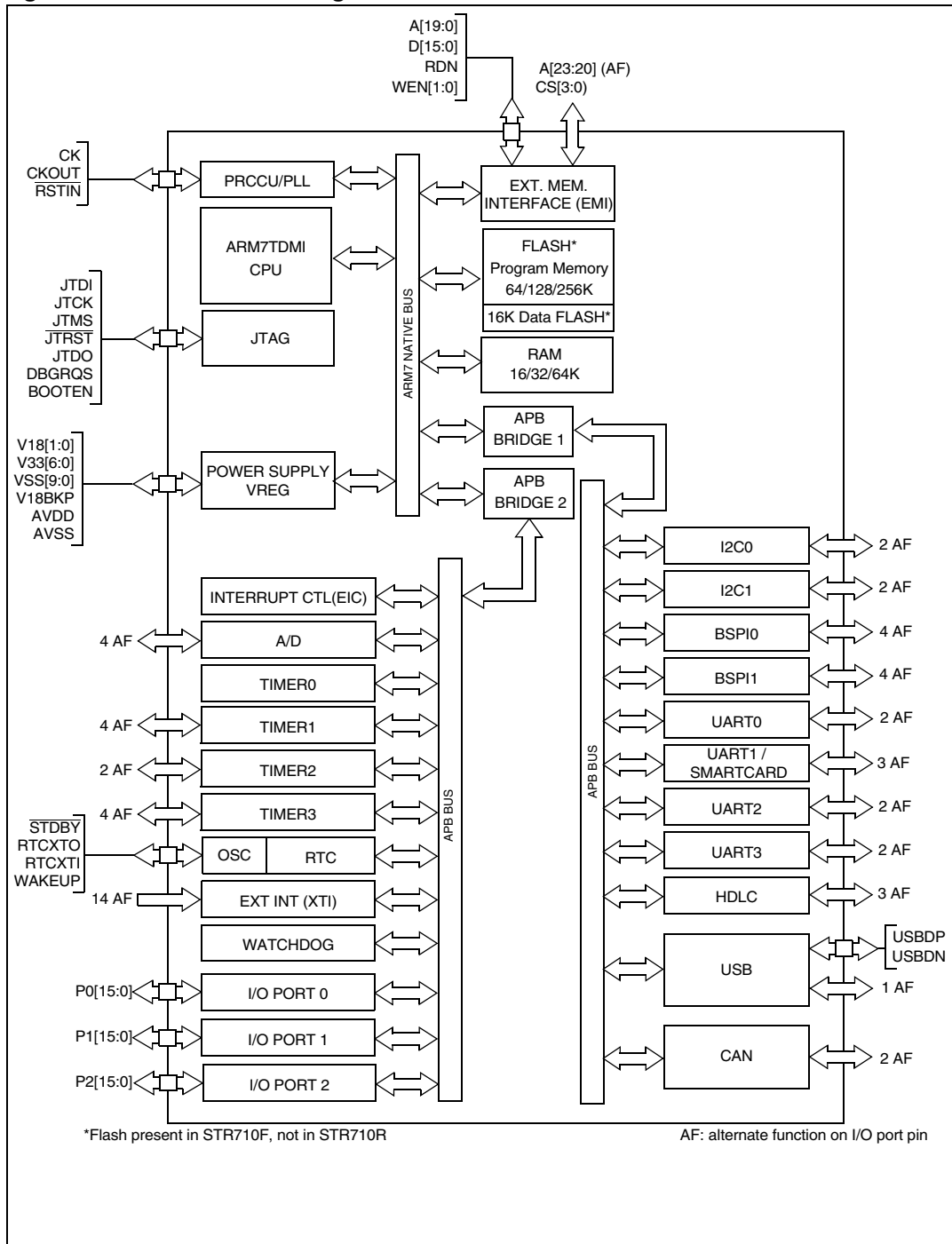

4.2 Related documentation

Available from www.arm.com:

ARM7TDMI Technical Reference Manual

Available from <http://www.st.com>:

STR71x Reference Manual

STR7 Flash Programming Reference Manual

AN1774 - STR710 Software development getting started

AN1775 - STR710 Hardware development getting started

AN1776 - STR710 Enhanced Interrupt Controller

AN1777 - STR710 Memory Mapping

AN1780 - Real Time Clock with STR710

AN1781 - Four 7 Segment Display Drive Using the STR710

The above is a selected list only, a full list STR71x application notes can be viewed at <http://www.st.com>.

4.3 Pin description for 144-pin packages

Figure 2. STR710 LQFP Pinout

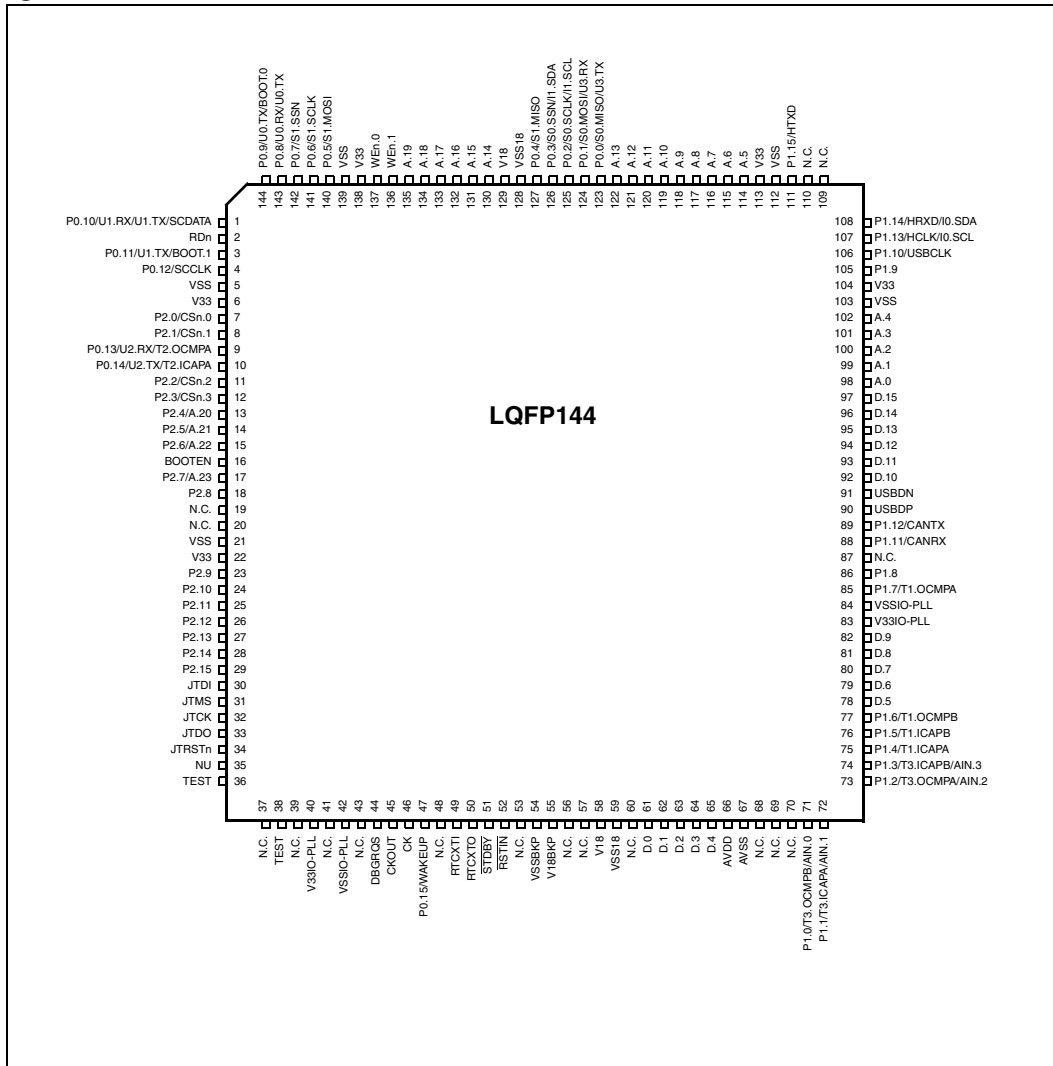

Table 2. STR710 BGA ball connections

	A	B	C	D	E	F	G	H	J	K	L	M
1	P0.10	P2.0	P2.1	VSS	P2.2	P2.6	BOOT EN	P2.12	P2.13	P2.15	JTDI	N.C.
2	VSS	RDn	P0.11	V33	P2.3	P2.8	P2.9	JTMS	JTRST _n	TEST	TEST	N.C.
3	V33	P0.9	P0.12	P0.13	P2.4	N.C.	P2.10	JTCK	NU	V33	N.C.	DBG RQS
4	P0.6	P0.7	P0.8	P0.14	P2.5	N.C.	P2.11	JTDO	CK	CKOUT	VSSIO-PLL	N.C.
5	A.19	WEn.1	WEn.0	P0.5	P2.7	VSS	P2.14	N.C.	RTCX-TO	RTCXTI	N.C.	P0.15
6	P0.3	A.15	A.16	A.17	A.18	V33	V18	N.C.	N.C.	V18BKP	VSS BKP	STDBY
7	P0.2	P0.1	P0.4	VSS18	V18	A.14	D.12	D.1	D.0	nc	VSS18	RSTIN
8	A.9	A.10	A.11	A.13	P0.0	A.0	D.11	P1.12/CANTX	N.C.	AVSS	D.3	D.2
9	VSS	V33	A.5	A.6	V33	D.15	D.10	P1.8	D.9	P1.0	N.C.	N.C.
10	A.8	N.C.	P1.15	P1.13	VSS	D.14	USBDN	P1.7	D.8	P1.5	P1.1	D.4
11	A.7	N.C.	P1.14	P1.10	A.2	D.13	USBDP	VSS	D.5	P1.4	P1.3	AVDD
12	A.12	A.4	A.3	P1.9	A.1	P1.11/CANRX	N.C.	V33IO-PLL	P1.6	D.7	D.6	P1.2

Legend / abbreviations for Table 3:

Type: I = input, O = output, S = supply, HiZ= high impedance,

In/Output level: C = CMOS 0.3V_{DD}/0.7V_{DD}

C_T = CMOS 0.3V_{DD}/0.7V_{DD} with input trigger

T_T = TTL 0.8V/2V with input trigger

C/T = Programmable levels: CMOS 0.3V_{DD}/0.7V_{DD} or TTL 0.8V / 2V

Port and control configuration:

Input: pu/pd= software enabled internal pull-up or pull down
 pu= in reset state, the internal 100kΩ weak pull-up is enabled.
 pd = in reset state, the internal 100kΩ weak pull-down is enabled.

Output: OD = open drain (logic level)
 PP = push-pull
 T = true OD, (P-Buffer and protection diode to V_{DD} not implemented),
 5V tolerant.

Table 3. STR710 pin description

Pin n°		Pin Name	Type	Reset State ¹⁾	Input		Output			Active in Stbby	Main function (after reset)	Alternate function	
LQFP144	BGA144				Input Level	interrupt	Capability	OD	PP				
1	A1	P0.10/U1.RX/ U1.TX/ SC.DATA	I/O	pd	C _T	X	4mA	T			Port 0.10	UART1: Receive Data input Note: This pin may be used for Smartcard DataIn/DataOut or single wire UART (half duplex) if programmed as Alternate Function Output. The pin will be tri-stated except when UART transmission is in progress	UART1: Transmit data output.
2	B2	\overline{RD}	O	⁵⁾					X			External Memory Interface: Active low read signal for external memory. It maps to the OE_N input of the external components.	
3	C2	P0.11/BOOT.1 /U1.TX	I/O	pd	C _T		4mA	X	X		Port 0.11	Select Boot Configuration input	UART1: Transmit data output.
4	C3	P0.12/SC.CLK	I/O	pd	C _T		4mA	X	X		Port 0.12	Smartcard reference clock output	
5	D1	V _{SS}	S									Ground voltage for digital I/Os ⁴⁾	
6	D2	V ₃₃	S									Supply voltage for digital I/Os ⁴⁾	
7	B1	P2.0/ \overline{CS} .0	I/O	⁸⁾	C _T		8mA	X	X		Port 2.0	External Memory Interface: Select Memory Bank 0 output Note: This pin is forced to output push-pull 1 mode at reset to allow boot from external memory	
8	C1	P2.1/ \overline{CS} .1	I/O	pu ₂₎	C _T		8mA	X	X		Port 2.1	External Memory Interface: Select Memory Bank 1 output	
9	D3	P0.13/U2.RX/ T2.OCMPA	I/O	pu	C _T	X	4mA	X	X		Port 0.13	UART2: Receive Data input	Timer2: Output Compare A output
10	D4	P0.14/U2.TX/ T2.ICAPA	I/O	pu	C _T		4mA	X	X		Port 0.14	UART2: Transmit data output	Timer2: Input Capture A input
11	E1	P2.2/ \overline{CS} .2	I/O	pu ₂₎	C _T		8mA	X	X		Port 2.2	External Memory Interface: Select Memory Bank 3 output	
12	E2	P2.3/ \overline{CS} .3	I/O	pu ₂₎	C _T		8mA	X	X		Port 2.3	External Memory Interface: Select Memory Bank 4 output	

Table 3. STR710 pin description

Pin n°		Pin Name	Type	Reset State ¹⁾	Input		Output			Active in Stdbby	Main function (after reset)	Alternate function
LQFP144	BGA144				Input Level	interrupt	Capability	OD	PP			
13	E3	P2.4/A.20	I/O	pd ₃₎	C _T		8mA	X	X		Port 2.4	External Memory Interface: address bus
14	E4	P2.5/A.21	I/O	pd ₃₎	C _T		8mA	X	X		Port 2.5	
15	F1	P2.6/A.22	I/O	pd ₃₎	C _T		8mA	X	X		Port 2.6	
16	G1	BOOTEN	I		C _T						Boot control input. Enables sampling of BOOT[1:0] pins	
17	E5	P2.7/A.23	I/O	pd ₃₎	C _T		8mA	X	X		Port 2.7	External Memory Interface: address bus
18	F2	P2.8	I/O	pu	C _T	X	4mA	X	X		Port 2.8	External interrupt INT2
19	F3	N.C.									Not connected (not bonded)	
20	F4	N.C.									Not connected (not bonded)	
21	F5	V _{SS}	S								Ground voltage for digital I/Os ⁴⁾	
22	F6	V ₃₃	S								Supply voltage for digital I/Os ⁴⁾	
23	G2	P2.9	I/O	pu	C _T	X	4mA	X	X		Port 2.9	External interrupt INT3
24	G3	P2.10	I/O	pu	C _T	X	4mA	X	X		Port 2.10	External interrupt INT4
25	G4	P2.11	I/O	pu	C _T	X	4mA	X	X		Port 2.11	External interrupt INT5
26	H1	P2.12	I/O	pu	C _T		4mA	X	X		Port 2.12	
27	J1	P2.13	I/O	pu	C _T		4mA	X	X		Port 2.13	
28	G5	P2.14	I/O	pu	C _T		4mA	X	X		Port 2.14	
29	K1	P2.15	I/O	pu	C _T		4mA	X	X		Port 2.15	
30	L1	JTDI	I		T _T						JTAG Data input. External pull-up required.	
31	H2	JTMS	I		T _T						JTAG Mode Selection Input. External pull-up required.	
32	H3	JTCK	I		C						JTAG Clock Input. External pull-up or pull-down required.	
33	H4	JTDO	O				8mA		X		JTAG Data output. Note: Reset state = HiZ.	
34	J2	JTRST	I		T _T						JTAG Reset Input. External pull-up required.	
35	J3	NU									Reserved, must be forced to ground.	
36	K2	TEST									Reserved, must be forced to ground.	
37	M1	N.C.									Not connected (not bonded)	
38	L2	TEST									Reserved, must be forced to ground.	
39	L3	N.C.									Not connected (not bonded)	

Table 3. STR710 pin description

Pin n°		Pin Name	Type	Reset State ¹⁾	Input		Output			Active in Stdbby	Main function (after reset)	Alternate function
LQFP144	BGA144				Input Level	interrupt	Capability	OD	PP			
40	K3	V _{33IO-PLL}	S								Supply voltage for digital I/O circuitry and for PLL reference	
41	M4	N.C.									Not connected (not bonded)	
42	L4	V _{SSIO-PLL}	S								Ground voltage for digital I/O circuitry and for PLL reference ⁴⁾	
43	M2	N.C.									Not connected (not bonded)	
44	M3	DBGRQS	I		C _T						Debug Mode request input (active high)	
45	K4	CKOUT	O				8mA		X		Clock output (f _{PCLK2}) Note: Enabled by CKDIS register in APB Bridge 2	
46	J4	CK	I		C						Reference clock input	
47	M5	P0.15/ WAKEUP	I		T _T	X				X	Port 0.15 Wakeup from Standby mode input. Note: This port is input only.	
48	L5	N.C.									Not connected (not bonded)	
49	K5	RTCXTI									Realtime Clock input and input of 32 kHz oscillator amplifier circuit	
50	J5	RTCXTO									Output of 32 kHz oscillator amplifier circuit	
51	M6	$\overline{\text{STDBY}}$	I/O		C _T		4mA	X		X	Input: Hardware Standby mode entry input active low. Caution: External pull-up to V ₃₃ required to select normal mode. Output: Standby mode active low output following Software Standby mode entry. Note: In Standby mode all pins are in high impedance except those marked Active in Stdbby	
52	M7	$\overline{\text{RSTIN}}$	I		C _T					X	Reset input	
53	H5	N.C.									Not connected (not bonded)	
54	L6	V _{SSBKP}			S					X	Stabilization for low power voltage regulator.	
55	K6	V _{18BKP}			S					X	Stabilization for low power voltage regulator. Requires external capacitors of at least 1μF between V _{18BKP} and V _{SS18BKP} . See Figure 5 . Note: If the low power voltage regulator is bypassed, this pin can be connected to an external 1.8V supply.	
56	J6	N.C.									Not connected (not bonded)	
57	H6	N.C.									Not connected (not bonded)	
58	G6	V ₁₈	S								Stabilization for main voltage regulator. Requires external capacitors of at least 10μF + 33nF between V ₁₈ and V _{SS18} . See Figure 5 .	

Table 3. STR710 pin description

Pin n°		Pin Name	Type	Reset State ¹⁾	Input		Output			Active in Stdbby	Main function (after reset)	Alternate function	
LQFP144	BGA144				Input Level	interrupt	Capability	OD	PP				
59	L7	V _{SS18}	S								Stabilization for main voltage regulator.		
60	K7	N.C.									Not connected (not bonded)		
61	J7	D.0	I/O	⁶⁾			8mA				External Memory Interface: data bus		
62	H7	D.1	I/O	⁶⁾			8mA						
63	M8	D.2	I/O	⁶⁾			8mA						
64	L8	D.3	I/O	⁶⁾			8mA						
65	M10	D.4	I/O	⁶⁾			8mA						
66	M11	V _{DDA}	S								Supply voltage for A/D Converter		
67	K8	V _{SSA}	S								Ground voltage for A/D Converter		
68	J8	N.C.									Not connected (not bonded)		
69	M9	N.C.									Not connected (not bonded)		
70	L9	N.C.									Not connected (not bonded)		
71	K9	P1.0/T3.OCM PB/AIN.0	I/O	pu	C _T		4mA	X	X		Port 1.0	Timer 3: Output Compare B	ADC: Analog input 0
72	L10	P1.1/T3.ICAP A/T3.EXTCLK/ AIN.1	I/O	pu	C _T		4mA	X	X		Port 1.1	Timer 3: Input Capture A or External Clock input	ADC: Analog input 1
73	M12	P1.2/T3.OCM PA/AIN.2	I/O	pu	C _T		4mA	X	X		Port 1.2	Timer 3: Output Compare A	ADC: Analog input 2
74	L11	P1.3/T3.ICAP B/AIN.3	I/O	pu	C _T		4mA	X	X		Port 1.3	Timer 3: Input Capture B	ADC: Analog input 3
75	K11	P1.4/T1.ICAP A/T1.EXTCLK	I/O	pu	C _T		4mA	X	X		Port 1.4	Timer 1: Input Capture A	Timer 1: External Clock input
76	K10	P1.5/T1.ICAP B	I/O	pu	C _T		4mA	X	X		Port 1.5	Timer 1: Input Capture B	
77	J12	P1.6/T1.OCM PB	I/O	pu	C _T		4mA	X	X		Port 1.6	Timer 1: Output Compare B	
78	J11	D.5	I/O	⁶⁾			8mA				External Memory Interface: data bus		
79	L12	D.6	I/O	⁶⁾			8mA						
80	K12	D.7	I/O	⁶⁾			8mA						
81	J10	D.8	I/O	⁶⁾			8mA						
82	J9	D.9	I/O	⁶⁾			8mA						

Table 3. STR710 pin description

Pin n°		Pin Name	Type	Reset State ¹⁾	Input		Output			Active in Stdby	Main function (after reset)	Alternate function	
LQFP144	BGA144				Input Level	interrupt	Capability	OD	PP				
83	H12	V _{33IO-PLL}	S								Supply voltage for digital I/O circuitry and for PLL reference ⁴⁾		
84	H11	V _{SSIO-PLL}	S								Ground voltage for digital I/O circuitry and for PLL reference ⁴⁾		
85	H10	P1.7/T1.OCM PA	I/O	pu	C _T		4mA	X	X		Port 1.7	Timer 1: Output Compare A	
86	H9	P1.8	I/O	pd	C _T		4mA	X	X		Port 1.8		
87	G12	N.C.									Not connected (not bonded)		
88	F12	P1.11/CANRX	I/O	pu	C _T	X	4mA	X	X		Port 1.11	CAN: receive data input Note: On STR710 and STR712 only	
89	H8	P1.12/CANTX	I/O	pu	C _T		4mA	X	X		Port 1.12	CAN: Transmit data output Note: On STR710 and STR712 only	
90	G11	USBDP	I/O		C _T						USB bidirectional data (data +). Reset state = HiZ Note: On STR710 and STR711 only This pin requires an external pull-up to V ₃₃ to maintain a high level.		
91	G10	USBDN	I/O		C _T						USB bidirectional data (data -). Reset state = HiZ Note: On STR710 and STR711 only.		
92	G9	D.10	I/O	⁶⁾			8mA				External Memory Interface: data bus		
93	G8	D.11	I/O	⁶⁾			8mA						
94	G7	D.12	I/O	⁶⁾			8mA						
95	F11	D.13	I/O	⁶⁾			8mA						
96	F10	D.14	I/O	⁶⁾			8mA						
97	F9	D.15	I/O	⁶⁾			8mA				External Memory Interface: address bus		
98	F8	A.0	O	⁷⁾			8mA	X					
99	E12	A.1	O	⁷⁾			8mA	X					
100	E11	A.2	O	⁷⁾			8mA	X					
101	C12	A.3	O	⁷⁾			8mA	X					
102	B12	A.4	O	⁷⁾			8mA	X					
103	E10	V _{SS}	S								Ground voltage for digital I/O circuitry ⁴⁾		
104	E9	V ₃₃	S								Supply voltage for digital I/O circuitry ⁴⁾		
105	D12	P1.9	I/O	pd	C _T		4mA	X	X		Port 1.9		
106	D11	P1.10/USBCLK	I/O	pd	C/T		4mA	X	X		Port 1.10	USB: 48 MHZ clock input	

Table 3. STR710 pin description

Pin n°		Pin Name	Type	Reset State ¹⁾	Input		Output			Active in Sdby	Main function (after reset)	Alternate function	
LQFP144	BGA144				Input Level	interrupt	Capability	OD	PP				
107	D10	P1.13/HCLK/ I0.SCL	I/O	pd	C _T	X	4mA	X	X		Port 1.13	HDLC: reference clock input	I2C clock
108	C11	P1.14/HRXD/ I0.SDA	I/O	pu	C _T	X	4mA	X	X		Port 1.14	HDLC: Receive data input	I2C serial data
109	B11	N.C.									Not connected (not bonded)		
110	B10	N.C.									Not connected (not bonded)		
111	C10	P1.15/HTXD	I/O	pu	C _T		4mA	X	X		Port 1.15	HDLC: Transmit data output	
112	A9	V _{SS}	S								Ground voltage for digital I/O circuitry ⁴⁾		
113	B9	V ₃₃	S								Supply voltage for digital I/O circuitry ⁴⁾		
114	C9	A.5	O	7)			8mA		X		External Memory Interface: address bus		
115	D9	A.6	O	7)			8mA		X				
116	A11	A.7	O	7)			8mA		X				
117	A10	A.8	O	7)			8mA		X				
118	A8	A.9	O	7)			8mA		X				
119	B8	A.10	O	7)			8mA		X				
120	C8	A.11	O	7)			8mA		X				
121	A12	A.12	O	7)			8mA		X				
122	D8	A.13	O	7)			8mA		X				
123	E8	P0.0/S0.MISO /U3.TX	I/O	pu	C _T		4mA	X	X		Port 0.0	SPI0 Master in/Slave out data	UART3 Transmit data output
												Note: Programming AF function selects UART by default. BSPI must be enabled by SPI_EN bit in the BOOTCR register.	
124	B7	P0.1/S0.MOSI /U3.RX	I/O	pu	C _T	X	4mA	X	X		Port 0.1	BSPI0: Master out/Slave in data	UART3: Receive Data input
												Note: Programming AF function selects UART by default. BSPI must be enabled by SPI_EN bit in the BOOTCR register.	

Table 3. STR710 pin description

Pin n°		Pin Name	Type	Reset State ¹⁾	Input		Output			Active in Stdby	Main function (after reset)	Alternate function	
LQFP144	BGA144				Input Level	interrupt	Capability	OD	PP				
125	A7	P0.2/S0.SCLK /I1.SCL	I/O	pu	C _T	X	4mA	X	X		Port 0.2	BSPI0: Serial Clock I2C1: Serial clock	
												Note: Programming AF function selects I2C by default. BSPI must be enabled by SPI_EN bit in the BOOTCR register.	
126	A6	P0.3/S0.SS [̄] /I1.SDA	I/O	pu	C _T		4mA	X	X		Port 0.3	SPI0: Slave Select input active low. I2C1: Serial Data	
												Note: Programming AF function selects I2C by default. BSPI must be enabled by SPI_EN bit in the BOOTCR register.	
127	C7	P0.4/S1.MISO	I/O	pu	C _T		4mA	X	X		Port 0.4	SPI1: Master in/Slave out data	
128	D7	V _{SS18}	S									Stabilization for main voltage regulator.	
129	E7	V ₁₈	S									Stabilization for main voltage regulator. Requires external capacitors of at least 10µF + 33nF between V ₁₈ and V _{SS18} . See Figure 5 .	
130	F7	A.14	O	⁷⁾			8mA		X		External Memory Interface: address bus		
131	B6	A.15	O	⁷⁾			8mA		X				
132	C6	A.16	O	⁷⁾			8mA		X				
133	D6	A.17	O	⁷⁾			8mA		X				
134	E6	A.18	O	⁷⁾			8mA		X				
135	A5	A.19	O	⁷⁾			8mA		X				
136	B5	$\overline{WE}.1$	O	⁵⁾			8mA		X			External Memory Interface: active low MSB write enable output	
137	C5	$\overline{WE}.0$	O	⁵⁾			8mA		X			External Memory Interface: active low LSB write enable output	
138	A3	V ₃₃	S									Supply voltage for digital I/Os ⁴⁾	
139	A2	V _{SS}	S									Ground voltage for digital I/Os ⁴⁾	
140	D5	P0.5/S1.MOSI	I/O	pu	C _T		4mA	X	X		Port 0.5	SPI1: Master out/Slave In data	
141	A4	P0.6/S1.SCLK	I/O	pu	C _T	X	4mA	X	X		Port 0.6	SPI1: Serial Clock	
142	B4	P0.7/S1.SS [̄]	I/O	pu	C _T		4mA	X	X		Port 0.7	SPI1: Slave Select input active low	

Table 3. STR710 pin description

Pin n°		Pin Name	Type	Reset State ¹⁾	Input		Output			Active in Stdby	Main function (after reset)	Alternate function	
LQFP144	BGA144				Input Level	interrupt	Capability	OD	PP				
143	C4	P0.8/U0.RX/ U0.TX	I/O	pd	C _T	X	4mA	T			Port 0.8	UART0: Receive Data input	UART0: Transmit data output.
											Note: This pin may be used for single wire UART (half duplex) if programmed as Alternate Function Output. The pin will be tri-stated except when UART transmission is in progress		
144	B3	P0.9/U0.TX/ BOOT.0	I/O	pd	C _T		4mA	X	X		Port 0.9	Select Boot Configuration input	UART0: Transmit data output

1. The Reset configuration of the I/O Ports is IPUPD (input pull-up/pull down). Refer to [Table 7 on page 29](#). The Port bit configuration at reset is PC0=1, PC1=1, PC2=0. The port data register bit (PD) value depends on the pu/pd column which specifies whether the pull-up or pull-down is enabled at reset
2. In reset state, these pins configured as Input PU/PD with weak pull-up enabled. They must be configured by software as Alternate Function (see [Table 7: Port bit configuration table on page 29](#)) to be used by the External Memory Interface.
3. In reset state, these pins configured as Input PU/PD with weak pull-down enabled to output Address 0x0000 0000 using the External Memory Interface. To access memory banks greater than 1Mbyte, they need to be configured by software as Alternate Function (see [Table 7: Port bit configuration table on page 29](#)).
4. V_{33IO-PLL} and V₃₃ are internally connected. V_{SSIO-PLL} and V_{SS} are internally connected.
5. During the reset phase, these pins are in input pull-up state. When reset is released, they are configured as Output Push-Pull.
6. During the reset phase, these pins are in input pull-up state. When reset is released, they are configured as Hi-Z.
7. During the reset phase, these pins are in input pull-down state. When reset is released, they are configured as Output Push-Pull.
8. During the reset phase, this pin is in input floating state. When reset is released, it is configured as Output Push-Pull.

4.4 Pin description for 64-pin packages

Figure 3. STR712/STR715 LQFP64 pinout

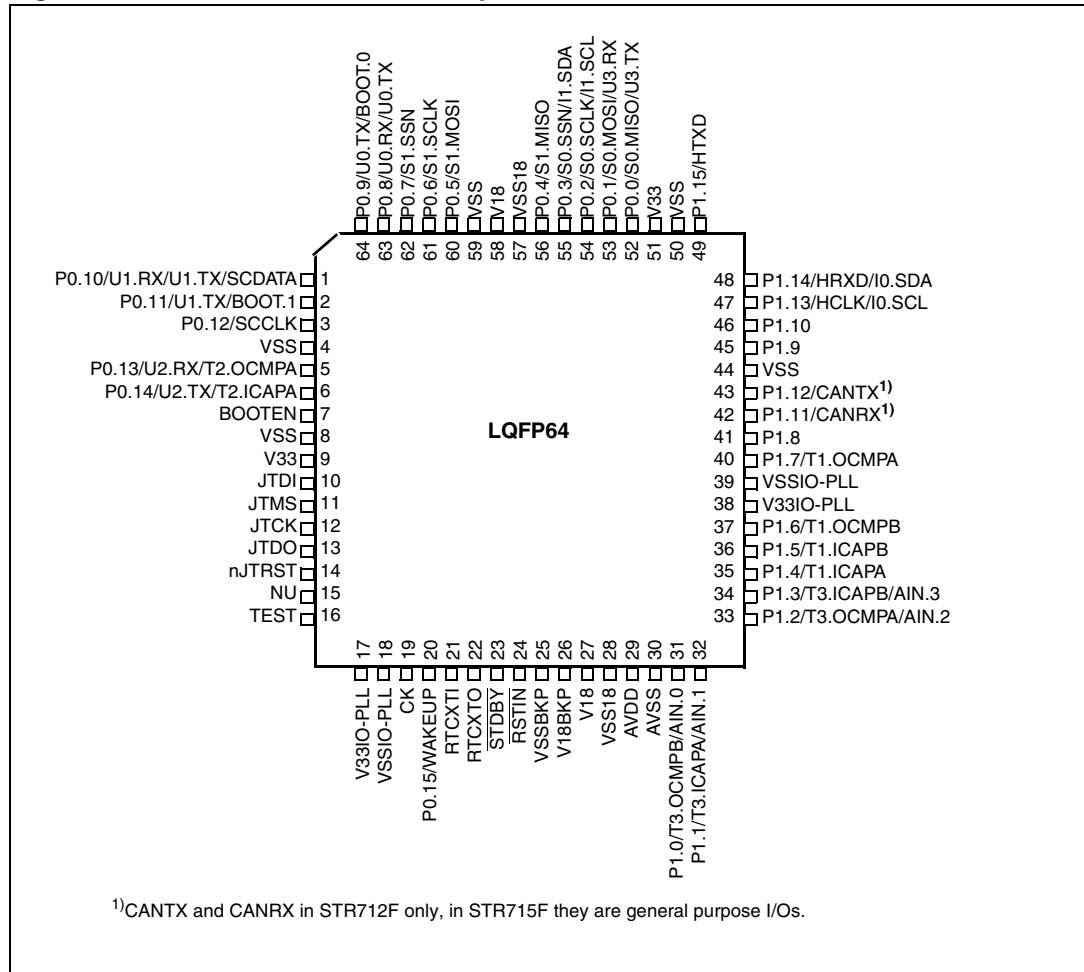

Figure 4. STR711 LQFP64 pinout

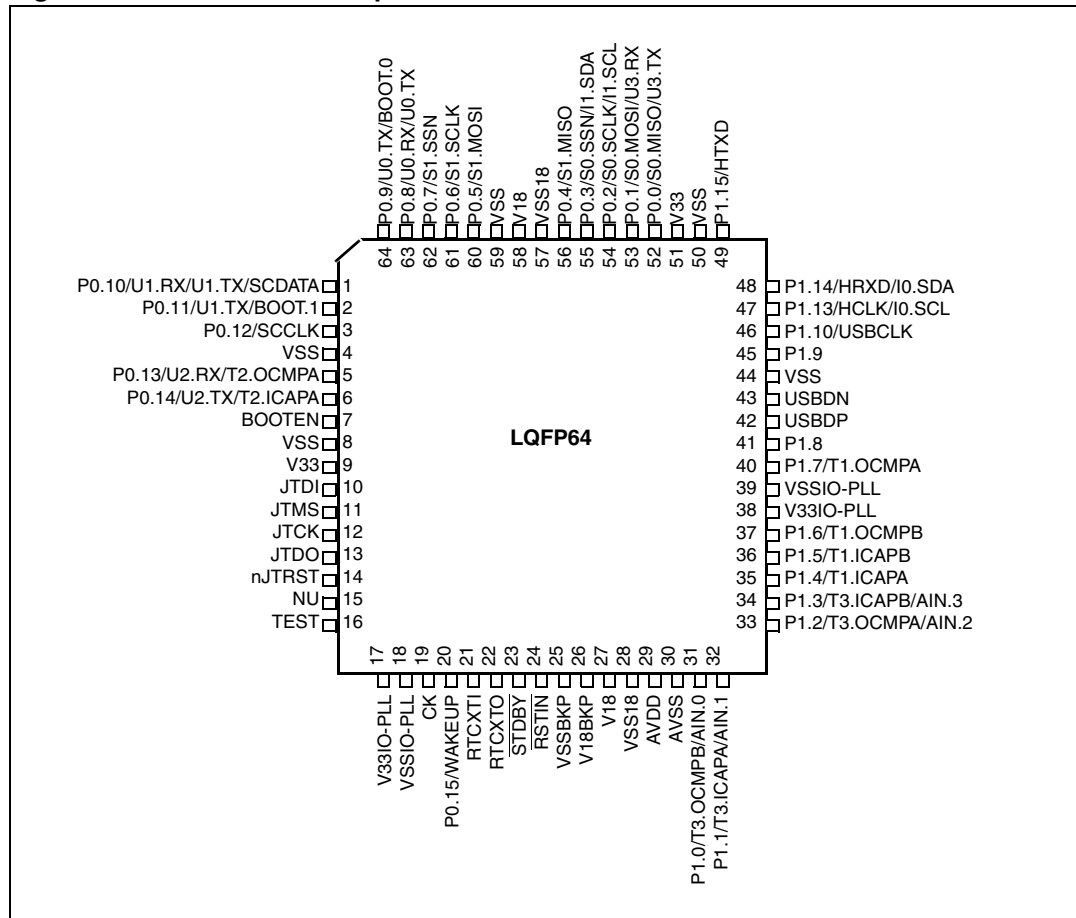

Table 4. STR711 BGA ball connections

	A	B	C	D	E	F	G	H
1	P0.10	P0.11	P0.12	P0.14	V33	JTCK	TEST	V33IO-PLL
2	P0.9	VSS	P0.13	VSS	JTMS	JTRSTn	P0.15	VSSIO-PLL
3	P0.5	P0.7	BOOTEN	JTDI	NU	STDBY	RTCXTI	CK
4	VSS18	VSS	P0.8	JTDO	AVDD	V18BKP	RSTIN	RTCXTO
5	P0.2	P0.4	V18	P0.6	P1.9	P1.0	V18	VSSBKP
6	V33	P0.1	P0.3	P1.13	USBDP	VSSIO-PLL	AVSS	VSS18
7	VSS	P0.0	P1.10	USBDN	P1.7	P1.6	P1.5	P1.1
8	P1.15	P1.14	VSS	P1.8	V33IO-PLL	P1.4	P1.3	P1.2

Table 5. STR712/715 BGA Ball Connections

	A	B	C	D	E	F	G	H
1	P0.10	P0.11	P0.12	P0.14	V33	JTCK	TEST	V33IO-PLL
2	P0.9	VSS	P0.13	VSS	JTMS	JTRSTn	P0.15	VSSIO-PLL
3	P0.5	P0.7	BOOTEN	JTDI	NU	\overline{STDBY}	RTCXTI	CK
4	VSS18	VSS	P0.8	JTDO	AVDD	V18BKP	\overline{RSTIN}	RTCXTO
5	P0.2	P0.4	V18	P0.6	P1.9	P1.0	V18	VSSBKP
6	V33	P0.1	P0.3	P1.13	P1.11/ CANRX ¹⁾	VSSIO-PLL	AVSS	VSS18
7	VSS	P0.0	P1.10	P1.12/ CANTX ¹⁾	P1.7	P1.6	P1.5	P1.1
8	P1.15	P1.14	VSS	P1.8	V33IO-PLL	P1.4	P1.3	P1.2

¹⁾CANTX and CANRX in STR712F only, in STR715F they are general purpose I/Os.

Legend / abbreviations for Table 6:

Type: I = input, O = output, S = supply, HiZ= high impedance,

In/Output level: C = CMOS 0.3V_{DD}/0.7V_{DD}

C_T= CMOS 0.8V / 2V with input trigger

T_T= TTL 0.3V/0.7V_{DD} with input trigger

C/T = Programmable levels: CMOS 0.3V_{DD}/0.7V_{DD} or TTL 0.8V / 2V

Port and control configuration:

Input: pu/pd= software enabled internal pull-up or pull down

pu= in reset state, the internal 100kΩ weak pull-up is enabled.

pd = in reset state, the internal 100kΩ weak pull-down is enabled.

Output: OD = open drain (logic level)

PP = push-pull

T = true OD, (P-Buffer and protection diode to V_{DD} not implemented),

5V tolerant.

Table 6. STR711/STR712/STR715 pin description

Pin n°		Pin Name	Type	Reset State ¹⁾	Input		Output			Active in Stbby	Main function (after reset)	Alternate function	
LQFP64	BGA64				Input Level	interrupt	Capability	OD	PP				
1	A1	P0.10/U1.RX/ U1.TX/ SC.DATA	I/O	pd	C _T	X	4mA	T			Port 0.10	UART1: Receive Data input	UART1: Transmit data output.
												Note: This pin may be used for Smartcard DataIn/DataOut or single wire UART (half duplex) if programmed as Alternate Function Output. The pin will be tri-stated except when UART transmission is in progress	
2	B1	P0.11/BOOT.1 /U1.TX	I/O	pd	C _T		4mA	X	X		Port 0.11	Select Boot Configuration input	UART1: Transmit data output.
3	C1	P0.12/SC.CLK	I/O	pd	C _T		4mA	X	X		Port 0.12	Smartcard reference clock output	
4	B2	V _{SS}	S								Ground voltage for digital I/Os ²⁾		
5	C2	P0.13/U2.RX/ T2.OCMPA	I/O	pu	C _T	X	4mA	X	X		Port 0.13	UART2: Receive Data input	Timer2: Output Compare A output
6	D1	P0.14/U2.TX/ T2.ICAPA	I/O	pu	C _T		4mA	X	X		Port 0.14	UART2: Transmit data output	Timer2: Input Capture A input
7	C3	BOOTEN	I		C _T						Boot control input. Enables sampling of BOOT[1:0] pins		
8	D2	V _{SS}	S								Ground voltage for digital I/Os ²⁾		
9	E1	V ₃₃	S								Supply voltage for digital I/Os ²⁾		
10	D3	JTDI	I		T _T						JTAG Data input. External pull-up required.		
11	E2	JTMS	I		T _T						JTAG Mode Selection Input. External pull-up required.		
12	F1	JTCK	I		C						JTAG Clock Input. External pull-up or pull-down required.		
13	D4	JTDO	O				8mA		X		JTAG Data output. Note: Reset state = HiZ.		
14	F2	JTRST	I		T _T						JTAG Reset Input. External pull-up required.		
15	E3	NU									Reserved, must be forced to ground.		
16	G1	TEST									Reserved, must be forced to ground.		
17	H1	V _{33IO-PLL}	S								Supply voltage for digital I/O circuitry and for PLL reference ²⁾		
18	H2	V _{SSIO-PLL}	S								Ground voltage for digital I/O circuitry and for PLL reference ²⁾		
19	H3	CK	I		C						Reference clock input		

Table 6. STR711/STR712/STR715 pin description

Pin n°		Pin Name	Type	Reset State ¹⁾	Input		Output			Active in Stdby	Main function (after reset)	Alternate function	
LQFP64	BGA64				Input Level	interrupt	Capability	OD	PP				
20	G2	P0.15/ WAKEUP	I		T _T	X				X	Port 0.15	Wakeup from Standby mode input.	
											Note: This port is input only.		
21	G3	RTCXTI									Realtime Clock input and input of 32 kHz oscillator amplifier circuit		
22	H4	RTCXTO									Output of 32 kHz oscillator amplifier circuit		
23	F3	$\overline{\text{STDBY}}$	I/O		C _T		4mA	X		X	Input: Hardware Standby mode entry input active low. Caution: External pull-up to V ₃₃ required to select normal mode. Output: Standby mode active low output following Software Standby mode entry. Note: In Standby mode all pins are in high impedance except those marked Active in Stdby.		
24	G4	$\overline{\text{RSTIN}}$	I		C _T					X	Reset input		
25	H5	V _{SSBKP}			S					X	Stabilization for low power voltage regulator.		
26	F4	V _{18BKP}			S					X	Stabilization for low power voltage regulator. Requires external capacitors of at least 1μF between V _{18BKP} and V _{SS18BKP} . See Figure 5 . Note: If the low power voltage regulator is bypassed, this pin can be connected to an external 1.8V supply.		
27	G5	V ₁₈	S								Stabilization for main voltage regulator. Requires external capacitors of at least 10μF + 33nF between V ₁₈ and V _{SS18} . See Figure 5 .		
28	H6	V _{SS18}	S								Stabilization for main voltage regulator.		
29	E4	V _{DDA}	S								Supply voltage for A/D Converter		
30	G6	V _{SSA}	S								Ground voltage for A/D Converter		
31	F5	P1.0/T3.OCM PB/AIN.0	I/O	pu	C _T		4mA	X	X		Port 1.0	Timer 3: Output Compare B	ADC: Analog input 0
32	H7	P1.1/T3.ICAP A/T3.EXTCLK /AIN.1	I/O	pu	C _T		4mA	X	X		Port 1.1	Timer 3: Input Capture A or External Clock input	ADC: Analog input 1
33	H8	P1.2/T3.OCM PA/AIN.2	I/O	pu	C _T		4mA	X	X		Port 1.2	Timer 3: Output Compare A	ADC: Analog input 2
34	G8	P1.3/T3.ICAP B/AIN.3	I/O	pu	C _T		4mA	X	X		Port 1.3	Timer 3: Input Capture B	ADC: Analog input 3
35	F8	P1.4/T1.ICAP A/T1.EXTCLK	I/O	pu	C _T		4mA	X	X		Port 1.4	Timer 1: Input Capture A	Timer 1: External Clock input

Table 6. STR711/STR712/STR715 pin description

Pin n°		Pin Name	Type	Reset State ¹⁾	Input		Output			Active in Sdby	Main function (after reset)	Alternate function	
LQFP64	BGA64				Input Level	interrupt	Capability	OD	PP				
36	G7	P1.5/T1.ICAP B	I/O	pu	C _T		4mA	X	X		Port 1.5	Timer 1: Input Capture B	
37	F7	P1.6/T1.OCM PB	I/O	pu	C _T		4mA	X	X		Port 1.6	Timer 1: Output Compare B	
38	E8	V _{33IO-PLL}	S								Supply voltage for digital I/O circuitry and for PLL reference ²⁾		
39	F6	V _{SSIO-PLL}	S								Ground voltage for digital I/O circuitry and for PLL reference ²⁾		
40	E7	P1.7/T1.OCM PA	I/O	pu	C _T		4mA	X	X		Port 1.7	Timer 1: Output Compare A	
41	D8	P1.8	I/O	pd	C _T		4mA	X	X		Port 1.8		
42	E6	P1.11/CANRX	I/O	pu	C _T	X	4mA	X	X		Port 1.11	CAN: receive data input Note: On STR710 and STR712 only	
43	D7	P1.12/CANTX	I/O	pu	C _T		4mA	X	X		Port 1.12	CAN: Transmit data output Note: On STR710 and STR712 only	
42	E6	USBDP	I/O		C _T						USB bidirectional data (data +). Reset state = HiZ Note: On STR710 and STR711 only This pin requires an external pull-up to V ₃₃ to maintain a high level.		
43	D7	USBDN	I/O		C _T						USB bidirectional data (data -). Reset state = HiZ Note: On STR710 and STR711 only.		
44	C8	V _{SS}	S								Ground voltage for digital I/O circuitry ²⁾		
45	E5	P1.9	I/O	pd	C _T		4mA	X	X		Port 1.9		
46	C7	P1.10/USBCLK	I/O	pd	C/T		4mA	X	X		Port 1.10	USB: 48 MHz clock input	
47	D6	P1.13/HCLK/I ₀ .SCL	I/O	pd	C _T	X	4mA	X	X		Port 1.13	HDLC: reference clock input	I2C clock
48	B8	P1.14/HRXD/I ₀ .SDA	I/O	pu	C _T	X	4mA	X	X		Port 1.14	HDLC: Receive data input	I2C serial data
49	A8	P1.15/HTXD	I/O	pu	C _T		4mA	X	X		Port 1.15	HDLC: Transmit data output	
50	A7	V _{SS}	S								Ground voltage for digital I/O circuitry ²⁾		
51	A6	V ₃₃	S								Supply voltage for digital I/O circuitry ²⁾		

Table 6. STR711/STR712/STR715 pin description

Pin n°		Pin Name	Type	Reset State ¹⁾	Input		Output			Active in Sdby	Main function (after reset)	Alternate function	
LQFP64	BGA64				Input Level	interrupt	Capability	OD	PP				
52	B7	P0.0/S0.MISO /U3.TX	I/O	pu	C _T		4mA	X	X		Port 0.0	SPI0 Master in/Slave out data	UART3 Transmit data output
												Note: Programming AF function selects UART by default. BSPI must be enabled by SPI_EN bit in the BOOTCR register.	
53	B6	P0.1/S0.MOSI /U3.RX	I/O	pu	C _T	X	4mA	X	X		Port 0.1	BSPI0: Master out/Slave in data	UART3: Receive Data input
												Note: Programming AF function selects UART by default. BSPI must be enabled by SPI_EN bit in the BOOTCR register.	
54	A5	P0.2/S0.SCLK /I1.SCL	I/O	pu	C _T	X	4mA	X	X		Port 0.2	BSPI0: Serial Clock	I2C1: Serial clock
												Note: Programming AF function selects I2C by default. BSPI must be enabled by SPI_EN bit in the BOOTCR register.	
55	C6	P0.3/S0.SS/I1.SDA	I/O	pu	C _T		4mA	X	X		Port 0.3	SPI0: Slave Select input active low.	I2C1: Serial Data
												Note: Programming AF function selects I2C by default. BSPI must be enabled by SPI_EN bit in the BOOTCR register.	
56	B5	P0.4/S1.MISO	I/O	pu	C _T		4mA	X	X		Port 0.4	SPI1: Master in/Slave out data	
57	A4	V _{SS18}	S								Stabilization for main voltage regulator.		
58	C5	V ₁₈	S								Stabilization for main voltage regulator. Requires external capacitors of at least 10μF + 33nF between V ₁₈ and V _{SS18} . See Figure 5 .		
59	B4	V _{SS}	S								Ground voltage for digital I/Os		
60	A3	P0.5/S1.MOSI	I/O	pu	C _T		4mA	X	X		Port 0.5	SPI1: Master out/Slave In data	
61	D5	P0.6/S1.SCLK	I/O	pu	C _T	X	4mA	X	X		Port 0.6	SPI1: Serial Clock	
62	B3	P0.7/S1.SS	I/O	pu	C _T		4mA	X	X		Port 0.7	SPI1: Slave Select input active low	

Table 6. STR711/STR712/STR715 pin description

Pin n°		Pin Name	Type	Reset State ¹⁾	Input		Output			Active in Stdbby	Main function (after reset)	Alternate function	
LQFP64	BGA64				Input Level	interrupt	Capability	OD	PP				
63	C4	P0.8/U0.RX/U0.TX	I/O	pd	C _T	X	4mA	T			Port 0.8	UART0: Receive Data input	UART0: Transmit data output.
											Note: This pin may be used for single wire UART (half duplex) if programmed as Alternate Function Output. The pin will be tri-stated except when UART transmission is in progress		
64	A2	P0.9/U0.TX/B00T.0	I/O	pd	C _T		4mA	X	X		Port 0.9	Select Boot Configuration input	UART0: Transmit data output

1. The Reset configuration of the I/O Ports is IPUPD (input pull-up/pull down). Refer to [Table 7 on page 29](#). The Port bit configuration at reset is PC0=1, PC1=1, PC2=0. The port data register bit (PD) value depends on the pu/pd column which specifies whether the pull-up or pull-down is enabled at reset
2. V_{33IO-PLL} and V₃₃ are internally connected. V_{SSIO-PLL} and V_{SS} are internally connected.

4.5 External connections

Figure 5. Recommended External Connection of V₁₈ and V_{18BKP} pins

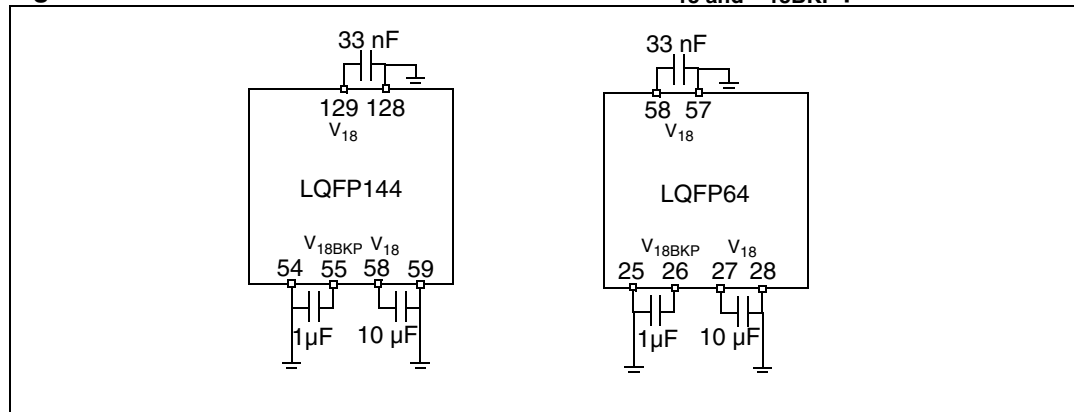

4.6 I/O port configuration

Table 7. Port bit configuration table

Configuration Mode		Input Buffer	PxD Register		PxC2 Register	PxC1 Register	PxC0 Register
			Read access	Write access			
INPUT	TTL Input Floating	TTL floating	I/O pin	don't care	0	0	1
	CMOS Input Floating	CMOS floating	I/O pin	don't care	0	1	0
	CMOS Input Pull-Down (IPUPD)	CMOS Pull-Down	I/O pin	0	0	1	1
	CMOS Input Pull-Up (IPUPD)	CMOS Pull-Up	I/O pin	1	0	1	1
	Analog input	AIN	0	don't care	0	0	0
OUTPUT	Output Open-Drain	N.A.	I/O pin	0 or 1	1	0	0
	Output Push-Pull	N.A.	last value written	0 or 1	1	0	1
	Alternate Function Open-Drain	CMOS floating	I/O pin	don't care	1	1	0
	Alternate Function Push-Pull	CMOS floating	I/O pin	don't care	1	1	1

Legend:

AIN: Analog Input

CMOS: CMOS Input levels

IPUPD: Input Pull Up /Pull Down

TTL: TTL Input levels

N.A.: not applicable. In Output mode, a read access to the port gets the output latch value.

4.7 Memory mapping

Figure 6. Memory map

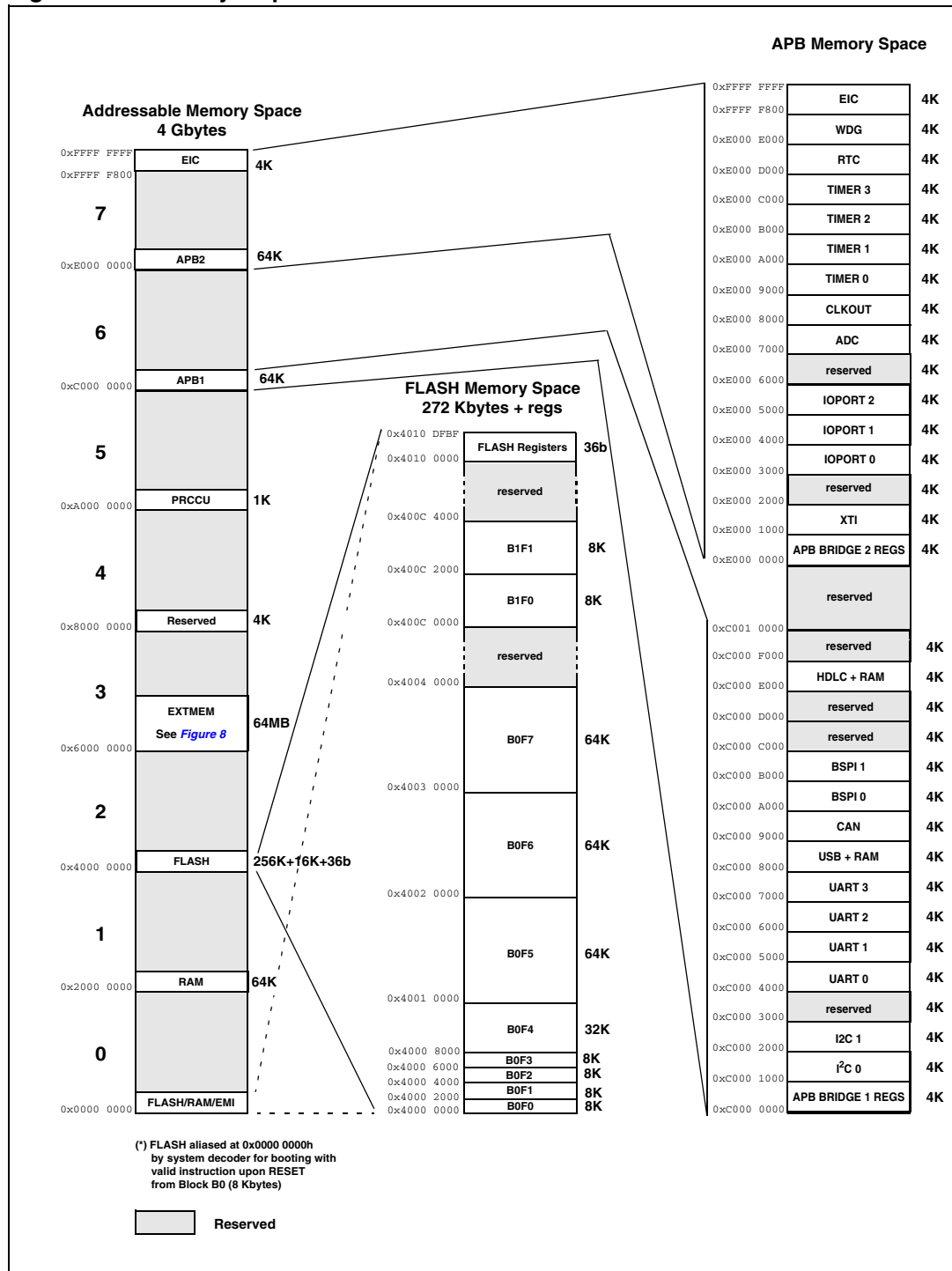

Figure 7. Mapping of Flash memory versions

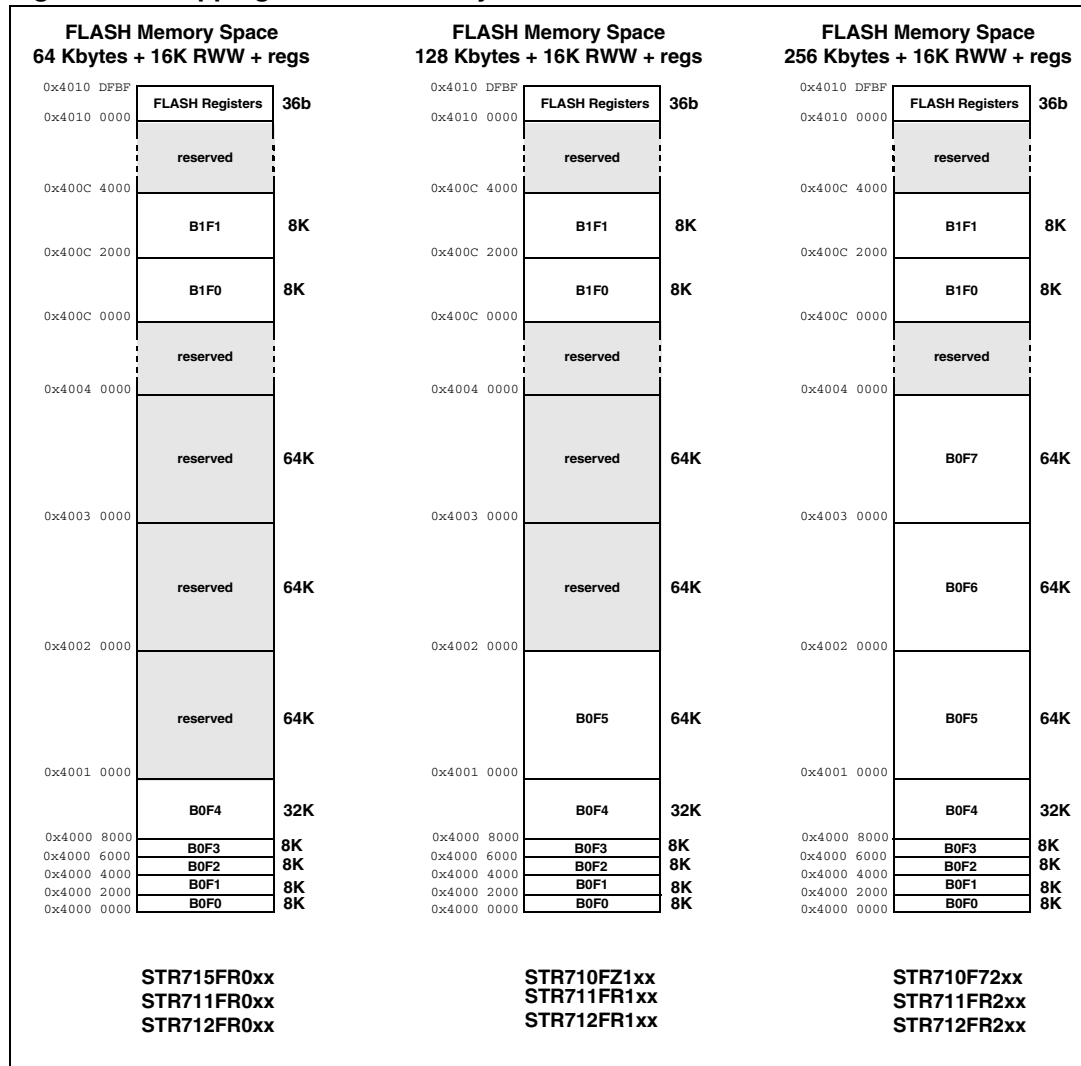
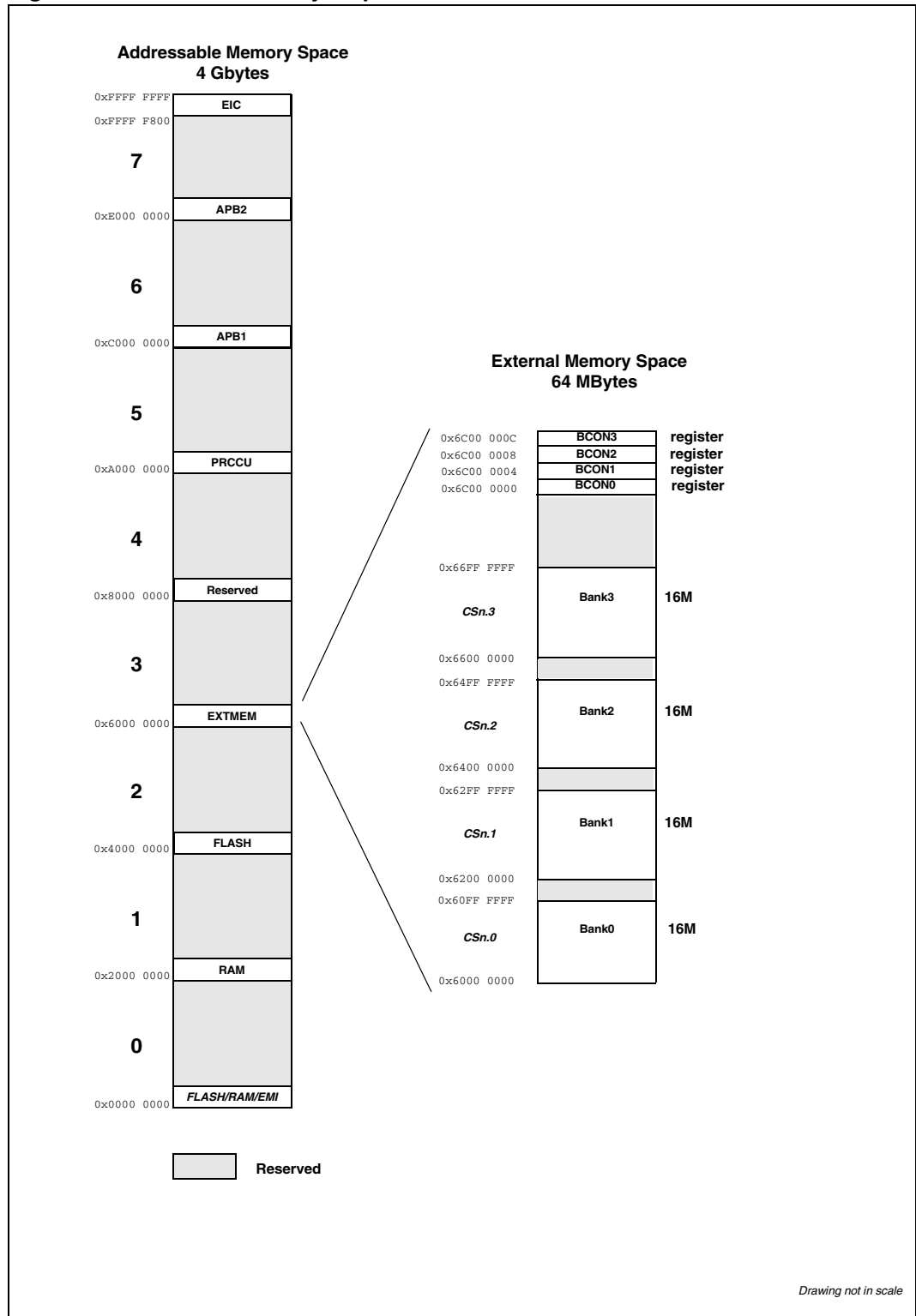

Table 8. RAM memory mapping

Part Number	RAM Size	Start Address	End Address
STR715FR0xx STR711FR0xx STR712FR0xx	16 Kbytes	0x2000 0000	0x2000 3FFF
STR710FZ1xx STR711FR1xx STR712FR1xx	32 Kbytes	0x2000 0000	0x2000 7FFF
STR710FR2xx STR710Rxx STR711FR2xx STR712FR2xx	64 Kbytes	0x2000 0000	0x2000 FFFF

Figure 8. External memory map



5 Electrical parameters

5.1 Parameter conditions

Unless otherwise specified, all voltages are referred to V_{SS} .

5.1.1 Minimum and maximum values

Unless otherwise specified the minimum and maximum values are guaranteed in the worst conditions of ambient temperature, supply voltage and frequencies by tests in production on 100% of the devices with an ambient temperature at $T_A=25^\circ\text{C}$ and $T_A=T_A\text{max}$ (given by the selected temperature range).

Data based on characterization results, design simulation and/or technology characteristics are indicated in the table footnotes and are not tested in production. Based on characterization, the minimum and maximum values refer to sample tests and represent the mean value plus or minus three times the standard deviation ($\text{mean}\pm 3\Sigma$).

5.1.2 Typical values

Unless otherwise specified, typical data are based on $T_A=25^\circ\text{C}$, $V_{33}=3.3\text{V}$ (for the $3.0\text{V}\leq V_{33}\leq 3.6\text{V}$ voltage range) and $V_{18}=1.8\text{V}$. They are given only as design guidelines and are not tested.

Typical ADC accuracy values are determined by characterization of a batch of samples from a standard diffusion lot over the full temperature range, where 95% of the devices have an error less than or equal to the value indicated ($\text{mean}\pm 2\Sigma$).

5.1.3 Typical curves

Unless otherwise specified, all typical curves are given only as design guidelines and are not tested.

5.1.4 Loading capacitor

The loading conditions used for pin parameter measurement are shown in [Figure 9](#).

5.1.5 Pin input voltage

The input voltage measurement on a pin of the device is described in [Figure 10](#).

Figure 9. Pin loading conditions

Figure 10. Pin input voltage

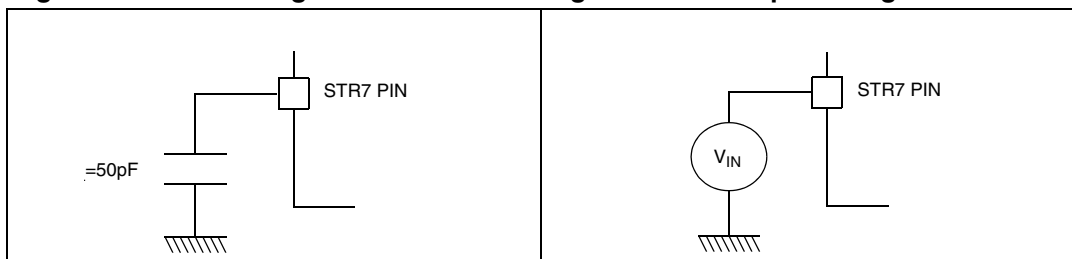

5.2 Absolute maximum ratings

Stresses above those listed as “absolute maximum ratings” may cause permanent damage to the device. This is a stress rating only and functional operation of the device under these conditions is not implied. Exposure to maximum rating conditions for extended periods may affect device reliability.

Table 9. Voltage characteristics

Symbol	Ratings	Min	Max	Unit
$V_{33} - V_{SS}$	External 3.3V Supply voltage (including AV_{DD} and $V_{33IO-PLL}$) ²⁾	-0.3	4.0	V
$V_{18BKP} - V_{SSBKP}$	Digital 1.8V Supply voltage on V_{18BKP} backup supply ²⁾	-0.3	2.0	
V_{IN}	Input voltage on true open drain pin (P0.10) ¹⁾	$V_{SS}-0.3$	+5.5	
	Input voltage on any other pin ¹⁾	$V_{SS}-0.3$	$V_{33}+0.3$	
$ \Delta V_{33x} $	Variations between different 3.3V power pins	50	50	mV
$ \Delta V_{18x} $	Variations between different 1.8V power pins ⁵⁾	25	25	
$ V_{SSX} - V_{SS} $	Variations between all the different ground pins	50	50	
$V_{ESD(HBM)}$	Electro-static discharge voltage (Human Body Model)	see : Absolute Maximum Ratings (Electrical Sensitivity) on page 48		
$V_{ESD(MM)}$	Electro-static discharge voltage (Machine Model)			

Table 10. Current characteristics

Symbol	Ratings	Max.	Unit
I_{V33}	Total current into $V_{33}/V_{33IO-PLL}$ power lines (source) ²⁾	150	mA
I_{VSS}	Total current out of $V_{SS}/V_{SSIO-PLL}$ ground lines (sink) ²⁾	150	
I_{IO}	Output current sunk by any I/O and control pin	25	
	Output current source by any I/Os and control pin	- 25	
$I_{INJ(PIN)}^{1) \& 3)}$	Injected current on \overline{RSTIN} pin	± 5	
	Injected current on CK pin	± 5	
	Injected current on any other pin ⁴⁾	± 5	
$\Sigma I_{INJ(PIN)}^{1)}$	Total injected current (sum of all I/O and control pins) ⁴⁾	± 25	

Notes:

- $I_{INJ(PIN)}$ must never be exceeded. This is implicitly insured if V_{IN} maximum is respected. If V_{IN} maximum cannot be respected, the injection current must be limited externally to the $I_{INJ(PIN)}$ value. A positive injection is induced by $V_{IN} > V_{33}$ while a negative injection is induced by $V_{IN} < V_{SS}$. For true open-drain pads, there is no positive injection current, and the corresponding V_{IN} maximum must always be respected
- All 3.3V power (V_{33} , AV_{DD} , $V_{33IO-PLL}$) and ground (V_{SS} , AV_{SS} , $V_{SSIO-PLL}$) pins must always be connected to the external 3.3V supply.
- Negative injection disturbs the analog performance of the device. See note in [Section 5.3.9: ADC characteristics on page 65](#).
- When several inputs are submitted to a current injection, the maximum $\Sigma I_{INJ(PIN)}$ is the absolute sum of the positive and negative injected currents (instantaneous values). These results are based on characterization with $\Sigma I_{INJ(PIN)}$ maximum current injection on four I/O port pins of the device.
- Only when using external 1.8V power supply. All the power (V_{18} , V_{18BKP}) and ground (V_{SS18} , V_{SSBKP}) pins must always be connected to the external 1.8V supply.

Table 11. Thermal characteristics

Symbol	Ratings	Value	Unit
T_{STG}	Storage temperature range	-65 to +150	°C
T_J	Maximum junction temperature (see Section 6.2: Thermal characteristics on page 71)		

5.3 Operating conditions

Subject to general operating conditions for V_{33} , and T_A .

Table 12. General Operating Conditions

Symbol	Parameter	Conditions	Min	Max	Unit
f_{MCLK}	Internal CPU Clock frequency	Accessing SRAM or external memory with 0 wait states	0	66	MHz
		Accessing FLASH in burst mode	0	50	
		Executing from FLASH with RWW	0	45 ¹⁾	
		Accessing FLASH with 0 wait states	0	33	
f_{PCLK}	Internal APB Clock frequency		0	33	MHz
V_{33}	Standard Operating Voltage (includes V_{33IO_PLL})		3.0	3.6	V
V_{18BKP}	Backup Operating Voltage		1.4	1.8	V
T_A	Ambient temperature range	6 Partnumber Suffix	-40	85	°C

1. Data guaranteed by characterization, not tested in production

Table 13. Operating Conditions at power-up / power-down

Symbol	Parameter	Conditions	Min	Typ	Max	Unit
t_{V33}	V_{33} rise time rate	Subject to general operating conditions for T_A .	20			$\mu\text{s/V}$
					20	ms/V

5.3.1 Supply current characteristics

The current consumption is measured as described in [Figure 9 on page 33](#) and [Figure 10 on page 33](#).

Total current consumption

The MCU is placed under the following conditions:

- All I/O pins in input mode with a static value at V_{33} or V_{SS} (no load)
- All peripherals are disabled except if explicitly mentioned.
- Embedded Regulators are used to provide 1.8V (except if explicitly mentioned)

Subject to general operating conditions for V_{33} , and T_A .

Table 14. Total Current consumption

Symbol	Parameter	Conditions	Typ ¹⁾	Max ²⁾	Unit
$I_{DD}^{4)}$	Supply current in RUN mode	$f_{MCLK}=66$ MHz, RAM execution	73.6	100	mA
		$f_{MCLK}=32$ MHz, Flash non-burst execution	49.3		
	Supply current in STOP mode	$T_A=25^\circ\text{C}$	10	50 ³⁾	μA
	Supply current in STANDBY mode	OSC32K bypassed	12	30	μA

Notes:

1. Typical data are based on $T_A=25^\circ\text{C}$, $V_{33}=3.3\text{V}$.
2. Data based on characterization results, tested in production at V_{33} , f_{MCLK} max. and T_A max.
3. Based on device characterisation, device power consumption in STOP mode at T_A 25°C is predicted to be 30 μA or less in 99.730020% of parts.
4. The conditions for these consumption measurements are described in application note AN2100.

Table 15. Typical power consumption data

Symbol	Parameter		Conditions	Typical current on V33	Unit
I _{DDRUN}	RUN mode current from RAM	All periphs ON	MCLK = 16 MHz, PCLK = FCLK = 16 MHz	23	mA
			MCLK = 32 MHz, PCLK = FCLK = 32 MHz	40	
			MCLK = 48 MHz, PCLK = FCLK = 24 MHz	50	
			MCLK = 64 MHz, PCLK = FCLK = 32 MHz	63	
		All periphs OFF	MCLK = 16 MHz	16	
			MCLK = 32 MHz	26	
			MCLK = 48 MHz	39	
			MCLK = 64 MHz	48	
	RUN mode current from FLASH	All periphs ON	MCLK = 16 MHz, PCLK = FCLK = 16 MHz	27	
			MCLK = 32 MHz, PCLK = FCLK = 32 MHz	47	
			MCLK = 48 MHz, PCLK = FCLK = 24 MHz	62	
		All periphs OFF	MCLK = 16 MHz	21	
MCLK = 32 MHz			36		
MCLK = 48 MHz			53		
I _{DDSLow}	SLOW mode current		MCLK = CK_AF (32 kHz), MVR off	1.7	
I _{DDWAIT}	WAIT mode current (all periphs ON)		PCLK = FCLK = 1 MHz	13	
I _{DDLWAIT}	LPWAIT mode current		CK_AF (32 kHz), Main VReg off, FLASH in power-down	37	
I _{DDSTOP}	STOP mode current		Main VReg off, FLASH in power down, RTC on	18	μA
			Main VReg off, FLASH in power down, RTC off	10	
I _{DDSB}	STANDBY mode current		LP VReg on, LVD on, RTC on	10	μA
			LP VReg off (ext 1.8V on V18BKP), LVD on, RTC on	9	
			LP VReg off (ext 1.8V on V18BKP), LVD off, RTC on	5	
			LP VReg off (ext 1.8V on V18BKP), LVD off, RTC off	1	

Figure 11. STOP I_{DD} vs. V_{33}

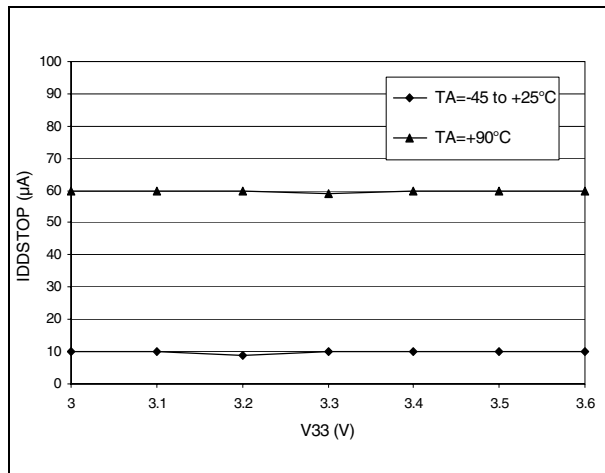

Figure 12. STANDBY I_{DD} vs. V_{33}

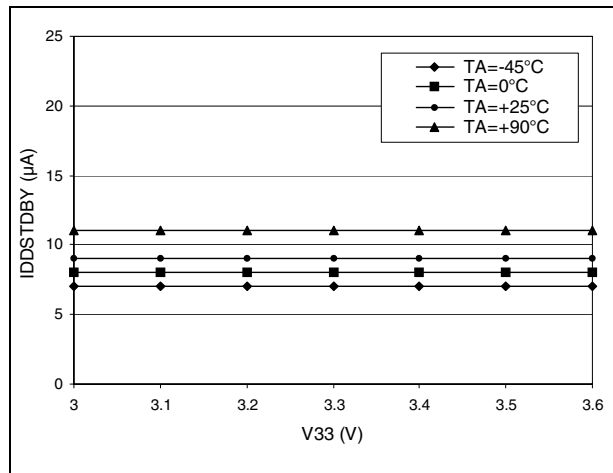
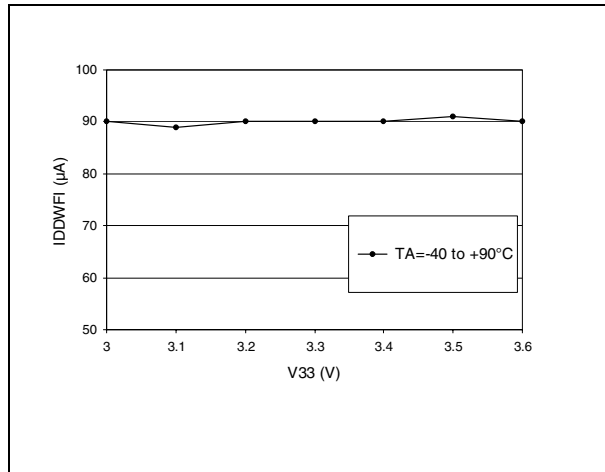

Figure 13. WFI I_{DD} vs. V_{33}



On-Chip Peripherals

Table 16. Peripheral current consumption

Symbol	Parameter	Conditions	Typ	Unit
$I_{DD(PLL1)}$	PLL1 supply current	$T_A = 25^\circ\text{C}$	3.42	mA
$I_{DD(PLL2)}$	PLL2 supply current		5.81	
$I_{DD(TIM)}$	TIM Timer supply current ¹⁾	$T_A = 25^\circ\text{C}, f_{PCLK} = 33\text{ MHz}$	0.88	
$I_{DD(BSPI)}$	BSPI supply current ²⁾		1.1	
$I_{DD(UART)}$	UART supply current ²⁾		1.05	
$I_{DD(I2C)}$	I2C supply current ²⁾		0.45	
$I_{DD(ADC)}$	ADC supply current when converting ⁵⁾		1.89	
$I_{DD(HDLC)}$	HDLC supply current ²⁾		1.82	
$I_{DD(USB)}$	USB supply current ²⁾		2.08	
$I_{DD(CAN)}$	CAN supply current ²⁾		1.11	

Notes:

1. Data based on a differential I_{DD} measurement between reset configuration and timer counter running at 16MHz. No IC/OC programmed (no I/O pads toggling).
2. Data based on a differential I_{DD} measurement between the on-chip peripheral when kept under reset and not clocked and the on-chip peripheral when clocked and not kept under reset. No I/O pads toggling.
3. Data based on a differential I_{DD} measurement between reset configuration and continuous A/D conversions.

5.3.2 Clock and timing characteristics

External Clock Sources

Subject to general operating conditions for V_{33} , and T_A .

Table 17. CK External Clock Characteristics

Symbol	Parameter	Conditions	Min	Typ	Max	Unit
f_{CK}	External clock source frequency		0		16.5	MHz
V_{CKH}	CK input pin high level voltage		$0.7 \times V_{33}$		V_{33}	V
V_{CKL}	CK input pin low level voltage		V_{SS}		$0.3 \times V_{33}$	
$t_{w(CK)}$ $t_{w(CK)}$	CK high or low time ¹⁾		25			ns
$t_{r(CK)}$ $t_{f(CK)}$	CK rise or fall time ¹⁾				5	
I_L	CK Input leakage current	$V_{SS} \leq V_{IN} \leq V_{33}$			± 1	μA

Notes:

1. Data based on design simulation and/or technology characteristics, not tested in production.

Figure 14. CK External Clock Source

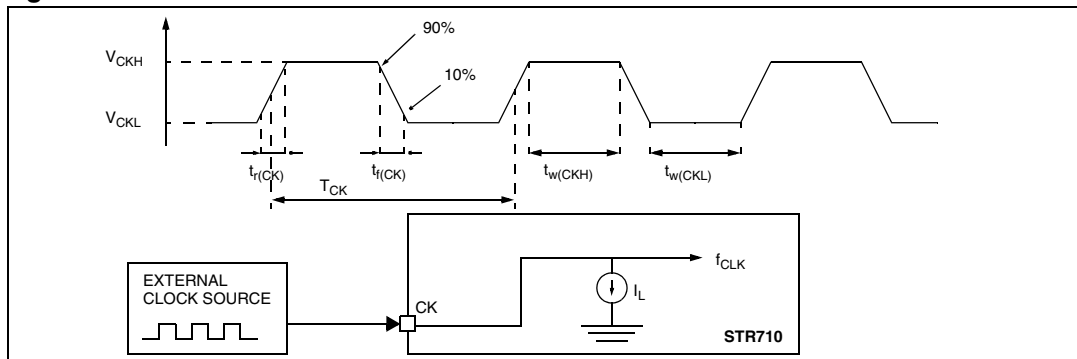

Table 18. RTCXT1 External Clock Characteristics

Symbol	Parameter	Conditions	Min	Typ	Max	Unit
f_{RTCXT1}	External clock source frequency		0		500	kHz
V_{RTCXT1H}	RTCXT1 input pin high level voltage		$0.7 \times V_{33}$		V_{33}	V
V_{RTCXT1L}	RTCXT1 input pin low level voltage		V_{SS}		$0.3 \times V_{33}$	
$t_{\text{w}}(\text{RTCXT1})$ $t_{\text{w}}(\text{RTCXT1})$	RTCXT1 high or low time ¹⁾		100			ns
$t_{\text{r}}(\text{RTCXT1})$ $t_{\text{f}}(\text{RTCXT1})$	RTCXT1 rise or fall time ¹⁾				5	
I_{L}	RTCXT1 Input leakage current	$V_{\text{SS}} \leq V_{\text{IN}} \leq V_{33}$			± 1	μA

Notes:

1. Data based on design simulation and/or technology characteristics, not tested in production.

OSC32K crystal / Ceramic resonator oscillator

The STR7 RTC clock can be supplied with a 32kHz Crystal/Ceramic resonator oscillators. All the information given in this paragraph are based on characterization results with specified typical external components. In the application, the resonator and the load capacitors have to be placed as close as possible to the oscillator pins in order to minimize output distortion and start-up stabilization time. Refer to the crystal resonator manufacturer for more details (frequency, package, accuracy...).

Table 19. 32K Oscillator characteristics (f_{OSC32K}= 32.768kHz)

Symbol	Parameter	Conditions	Typ	Unit
R _F	Feedback resistor		2.7	MΩ
C _{L1} C _{L2}	Recommended load capacitance versus equivalent serial resistance of the crystal (R _S) ¹⁾	R _S =40KΩ	12.5	pF
i ₂	RTCXT2 driving current	V ₃₃ =3.3V V _{IN} =V _{SS}	3.2	μA
g _m	Oscillator Transconductance		8	μA/V
t _{SU(OSC32KHZ)} ²⁾	startup time	V ₃₃ is stabilized	5	s

Notes:

1. The oscillator selection can be optimized in terms of supply current using an high quality resonator with small R_S value for example MSIV-TIN32.768kHz. Refer to crystal manufacturer for more details
2. t_{SU(OSC32KHZ)} is the start-up time measured from the moment it is enabled (by software) to a stabilized 32kHz oscillation is reached. This value is measured for a standard crystal resonator and it can vary significantly with the crystal manufacturer

Figure 15. Typical Application with a 32kHz Crystal

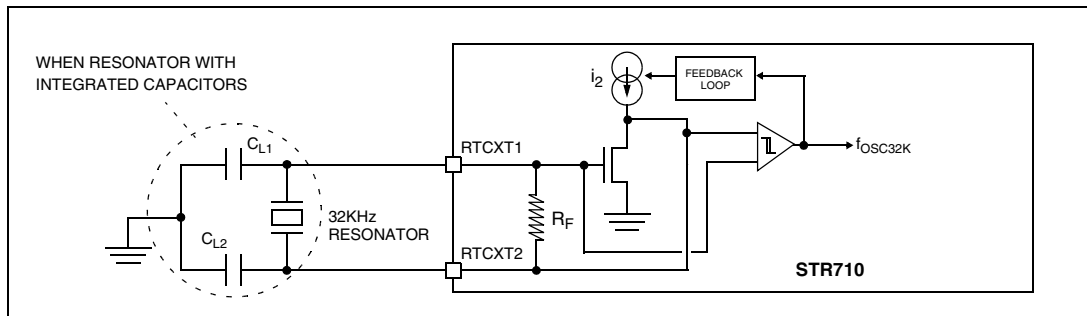
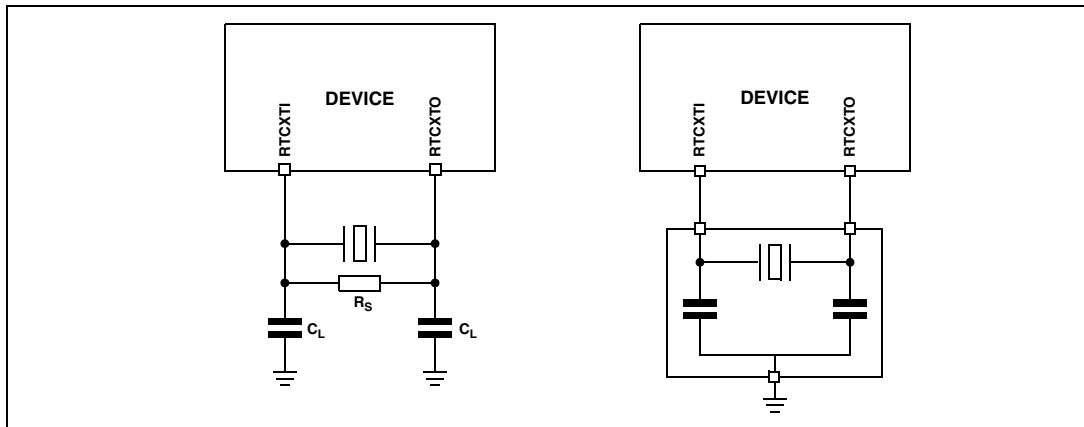

Figure 16. RTC crystal oscillator and resonator



PLL electrical characteristics

$V_{33} = 3.0$ to $3.6V$, $V_{33IOPLL} = 3.0$ to $3.6V$, $T_A = -40 / 85^\circ C$ unless otherwise specified.

Table 20. PLL1 characteristics

Symbol	Parameter	Test Conditions	Value			Unit
			Min	Typ	Max	
$f_{PLLCLK1}$	PLL multiplier output clock	$f_{PLL1} \times 24$			165	MHz
f_{PLL1}	PLL input clock	FREF_RANGE = 0	1.5		3.0	MHz
		FREF_RANGE = 1 MX[1:0]='00' or '01'	3.0		8.25	MHz
	FREF_RANGE = 1 MX[1:0]='10' or '11'	3.0		6	MHz	
	PLL input clock duty cycle		25		75	%
f_{FREE1}	PLL free running frequency	FREF_RANGE = 0 MX[1:0]='01' or '11'		125		kHz
		FREF_RANGE = 0 MX[1:0]='00' or '10'		250		kHz
		FREF_RANGE = 1 MX[1:0]='01' or '11'		250		kHz
		FREF_RANGE = 1 MX[1:0]='00' or '10'		500		kHz
t_{LOCK1}	PLL lock time	FREF_RANGE = 0 Stable Input Clock Stable $V_{33IOPLL}$, V_{18}			300	μs
		FREF_RANGE = 1 Stable Input Clock Stable $V_{33IOPLL}$, V_{18}			600	μs
$\Delta t_{JITTER1}$	PLL jitter (peak to peak)	$f_{PLL} = 4$ MHz, MX[1:0]='11' Global Output division = 32 (Output Clock = 2 MHz)		0.7	2	ns

Table 21. PLL2 characteristics

Symbol	Parameter	Test Conditions	Value			Unit
			Min	Typ	Max	
f_{PLLCLK2}	PLL multiplier output clock	$f_{\text{PLL}} \times 28$			140	MHz
f_{PLL2}	PLL input clock	FREF_RANGE = 0	1.5		3.0	MHz
		FREF_RANGE = 1	3.0		5	MHz
t_{LOCK2}	PLL lock time	FREF_RANGE = 0 Stable Input Clock Stable $V_{33\text{IOPLL}}$, V_{18}			300	μs
		FREF_RANGE = 1 Stable Input Clock Stable $V_{33\text{IOPLL}}$, V_{18}			600	μs
$\Delta t_{\text{JITTER2}}$	PLL jitter (peak to peak)	$t_{\text{PLL}} = 4 \text{ MHz}$, $\text{MX}[1:0]=\text{'11'}$ Global Output division = 32 (Output Clock = 2 MHz)		0.7	2	ns

Table 22. Low-power mode wake-up timing

Symbol	Parameter	Typ	Unit
t_{WULPWF1}	Wake-up from LPWF1 mode	26 ⁽¹⁾	μs
t_{WUSTOP}	Wake-up from STOP mode	2048	CLK Cycles
t_{WUSTBY}	Wake-up from STANDBY mode	2048 CLK Cycles + 8 CLK2 Cycles ⁽²⁾	Cycles

1. Clock selected is CK2_16, Main VReg OFF and Flash in power-down

2. Refer to Figure 7. Reset General Timing in the STR71xF Reference Manual (UM0084)

5.3.3 Memory characteristics

Flash memory

$V_{33} = 3.0$ to $3.6V$, $T_A = -40$ to $85\text{ }^\circ\text{C}$ unless otherwise specified.

Table 23. Flash memory characteristics

Symbol	Parameter	Test Conditions	Value			Unit
			Min.	Typ	Max ¹⁾	
t_{PW}	Word Program			40		μs
t_{PDW}	Double Word Program			60		μs
t_{PB0}	Bank 0 Program (256K)	Double Word Program		1.6	2.1	s
t_{PB1}	Bank 1 Program (16K)	Double Word Program		130	170	ms
t_{ES}	Sector Erase (64K)	Not preprogrammed Preprogrammed		2.3 1.9	4.0 3.3	s
t_{ES}	Sector Erase (8K)	Not preprogrammed Preprogrammed		0.7 0.6	1.1 1.0	s
t_{ES}	Bank 0 Erase (256K)	Not preprogrammed Preprogrammed		8.0 6.6	13.7 11.2	s
t_{ES}	Bank 1 Erase (16K)	Not preprogrammed Preprogrammed		0.9 0.8	1.5 1.3	s
t_{RPD} ²⁾	Recovery when disabled				20	μs
t_{PSL} ²⁾	Program Suspend Latency				10	μs
t_{ESL} ²⁾	Erase Suspend Latency				300	μs
N_{END_B0}	Endurance (Bank 0 sectors)		10			kcycles
N_{END_B1}	Endurance (Bank 1 sectors)		100			kcycles
t_{RET}	Data Retention (Bank 0 and Bank 1)	$T_A=85^\circ$	20			Years
t_{ESR}	Erase Suspend Rate	Min time from Erase Resume to next Erase Suspend	20			ms

Notes:

1. $T_A=45^\circ\text{C}$ after 0 cycles. Guaranteed by characterization, not tested in production.
2. Guaranteed by design, not tested in production

5.3.4 EMC characteristics

Susceptibility tests are performed on a sample basis during product characterization.

Functional EMS (Electro Magnetic Susceptibility)

Based on a simple running application on the product (toggling 2 LEDs through I/O ports), the product is stressed by two electro magnetic events until a failure occurs (indicated by the LEDs).

- **ESD:** Electro-Static Discharge (positive and negative) is applied on all pins of the device until a functional disturbance occurs. This test conforms with the IEC 1000-4-2 standard.
- **FTB:** A Burst of Fast Transient voltage (positive and negative) is applied to V_{DD} and V_{SS} through a 100pF capacitor, until a functional disturbance occurs. This test conforms with the IEC 1000-4-4 standard.

A device reset allows normal operations to be resumed. The test results are given in the table below based on the EMS levels and classes defined in application note AN1709.

Designing hardened software to avoid noise problems

EMC characterization and optimization are performed at component level with a typical application environment and simplified MCU software. It should be noted that good EMC performance is highly dependent on the user application and the software in particular.

Therefore it is recommended that the user applies EMC software optimization and prequalification tests in relation with the EMC level requested for his application.

Software recommendations:

The software flowchart must include the management of runaway conditions such as:

- Corrupted program counter
- Unexpected reset
- Critical Data corruption (control registers...)

Prequalification trials:

Most of the common failures (unexpected reset and program counter corruption) can be reproduced by manually forcing a low state on the RESET pin or the Oscillator pins for 1 second.

To complete these trials, ESD stress can be applied directly on the device, over the range of specification values. When unexpected behavior is detected, the software can be hardened to prevent unrecoverable errors occurring (see application note AN1015).

In the case of an ARM7 CPU, in order to write robust code that can withstand all kinds of stress, such as very strong electromagnetic disturbance, it is mandatory that the Data Abort, Prefetch Abort and Undefined Instruction exceptions are managed by the application software. This will prevent the code going into an undefined state or performing any unexpected operation.

Table 24. EMS data

Symbol	Parameter	Conditions	Level/Class
V _{FESD}	Voltage limits to be applied on any I/O pin to induce a functional disturbance	V ₃₃ =3.3V, T _A =+25°C, f _{MCLK} =32MHz conforms to IEC 1000-4-2	2B
V _{EFTB}	Fast transient voltage burst limits to be applied through 100pF on V _{DD} and V _{SS} pins to induce a functional disturbance	V ₃₃ =3.3V, T _A =+25°C, f _{MCLK} =32MHz conforms to IEC 1000-4-4	4A

Electro Magnetic Interference (EMI)

Based on a simple application running on the product (toggling 2 LEDs through the I/O ports), the product is monitored in terms of emission. This emission test is in line with the norm SAE J 1752/3 which specifies the board and the loading of each pin.

Table 25. EMI data

Symbol	Parameter	Conditions	Monitored Frequency Band	Max vs. [f _{OSC4M} /f _{HCLK}]		Unit
				16/48MHz	16/8MHz	
S _{EMI}	Peak level	V ₃₃ =3.3V, T _A =+25°C, LQFP64 package conforming to SAE J 1752/3	0.1MHz to 30 MHz	17	19	dBμV
			30 MHz to 130 MHz	17	16	
			130 MHz to 1GHz	11	11	
			SAE EMI Level	4	3	-

Notes:

1. Not tested in production.
2. BGA and LQFP devices have similar EMI characteristics.

Absolute Maximum Ratings (Electrical Sensitivity)

Based on three different tests (ESD, LU and DLU) using specific measurement methods, the product is stressed in order to determine its performance in terms of electrical sensitivity. For more details, refer to the application note AN1181.

Electro-Static Discharge (ESD)

Electro-Static Discharges (a positive then a negative pulse separated by 1 second) are applied to the pins of each sample according to each pin combination. The sample size depends on the number of supply pins in the device (3 parts*(n+1) supply pin). Two models can be simulated: Human Body Model and Machine Model. This test conforms to the JESD22-A114A/A115A standard.

Table 26. ESD Absolute Maximum ratings

Symbol	Ratings	Conditions	Maximum value ¹⁾	Unit
V _{ESD(HBM)}	Electro-static discharge voltage (Human Body Model)	T _A =+25°C	2000	V
V _{ESD(MM)}	Electro-static discharge voltage (Machine Model)		200	
V _{ESD(CDM)}	Electro-static discharge voltage (Charge Device Model)		750 on corner pins, 500 on others	

Notes:

1. Data based on characterization results, not tested in production.

Static and Dynamic Latch-Up

- **LU:** 3 complementary static tests are required on 10 parts to assess the latch-up performance. A supply overvoltage (applied to each power supply pin) and a current injection (applied to each input, output and configurable I/O pin) are performed on each sample. This test conforms to the EIA/JESD 78 IC latch-up standard. For more details, refer to the application note AN1181.
- **DLU:** Electro-Static Discharges (one positive then one negative test) are applied to each pin of 3 samples when the micro is running to assess the latch-up performance in dynamic mode. Power supplies are set to the typical values, the oscillator is connected as near as possible to the pins of the micro and the component is put in reset mode. This test conforms to the IEC1000-4-2 and SAEJ1752/3 standards. For more details, refer to the application note AN1181.

Electrical Sensitivities

Symbol	Parameter	Conditions	Class ¹⁾
LU	Static latch-up class	T _A =+25°C	A
		T _A =+85°C	A
		T _A =+105°C	A
DLU	Dynamic latch-up class	V _{DD} =3.3V, f _{OSC4M} =4MHz, f _{MCLK} =32MHz, T _A =+25°C	A

Notes:

1. Class description: A Class is an STMicroelectronics internal specification. All its limits are higher than the JEDEC specifications, that means when a device belongs to Class A it exceeds the JEDEC standard. B Class strictly covers all the JEDEC criteria (international standard).

5.3.5 I/O port pin characteristics

General characteristics

Subject to general operating conditions for V_{33} and T_A unless otherwise specified. All unused pins must be kept at a fixed voltage: using the output mode of the I/O for example or an external pull-up or pull-down resistor.

Table 27. I/O static characteristics

Symbol	Parameter	Conditions	Min	Typ	Max	Unit
V_{IL}	Input low level voltage ¹⁾	CMOS ports			$0.3V_{33}$	V
V_{IH}	Input high level voltage ¹⁾		$0.7V_{33}$			
V_{hys}	Schmitt trigger voltage hysteresis ²⁾			0.8		V
V_{IL}	Input low level voltage ¹⁾	P0.15 WAKEUP		0.9	0.8	V
V_{IH}	Input high level voltage ¹⁾		2	1.35		
V_{hys}	Schmitt trigger voltage hysteresis ²⁾			0.4		V
V_{IL}	Input low level voltage ¹⁾	TTL ports			0.8	V
V_{IH}	Input high level voltage ¹⁾		2.0			
$I_{INJ(PIN)}$	Injected Current on any I/O pin				± 4	mA
$\Sigma I_{INJ(PIN)}$ ³⁾	Total injected current (sum of all I/O and control pins)				± 25	
I_{lkg}	Input leakage current ⁴⁾	$V_{SS} \leq V_{IN} \leq V_{33}$			± 1	μA
R_{PU}	Weak pull-up equivalent resistor ⁵⁾	$V_{IN} = V_{SS}$	110	150	700	k Ω
R_{PD}	Weak pull-down equivalent resistor ⁵⁾	$V_{IN} = V_{33}$	110	150	700	k Ω
C_{IO}	I/O pin capacitance			5		pF

Notes:

1. Data based on characterization results, not tested in production.
2. Hysteresis voltage between Schmitt trigger switching levels. Based on characterization results, not tested.
3. When the current limitation is not possible, the V_{IN} absolute maximum rating must be respected, otherwise refer to $I_{INJ(PIN)}$ specification. A positive injection is induced by $V_{IN} > V_{33}$ while a negative injection is induced by $V_{IN} < V_{SS}$. Refer to [Section 5.2 on page 34](#) for more details.
4. Leakage could be higher than max. if negative current is injected on adjacent pins.
5. The R_{PU} pull-up and R_{PD} pull-down equivalent resistor are based on a resistive transistor (corresponding I_{PU} and I_{PD} current characteristics described in [Figure 18](#) to [Figure 19](#)).

Figure 17. R_{PU} vs. V_{33} with $V_{IN}=V_{SS}$

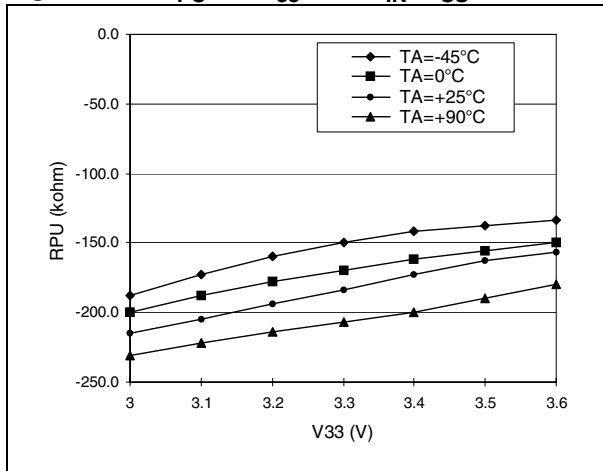

Figure 18. I_{PU} vs. V_{33} with $V_{IN}=V_{SS}$

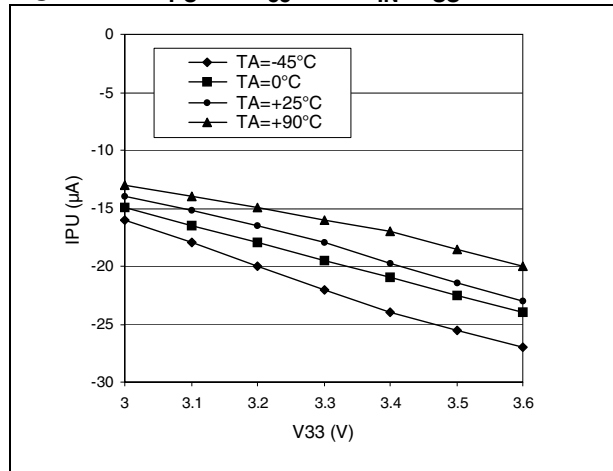

Figure 19. R_{PD} vs. V_{33} with $V_{IN}=V_{33}$

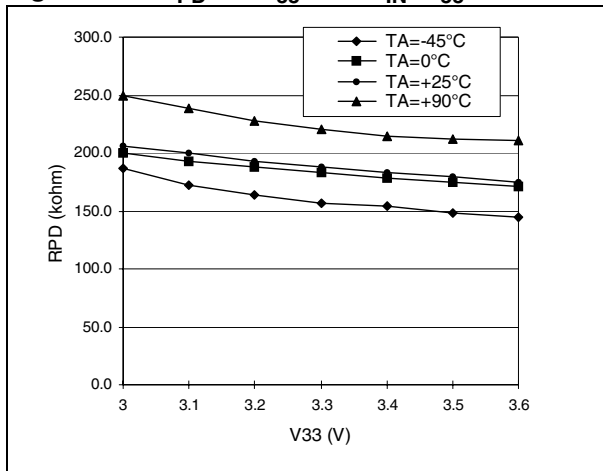
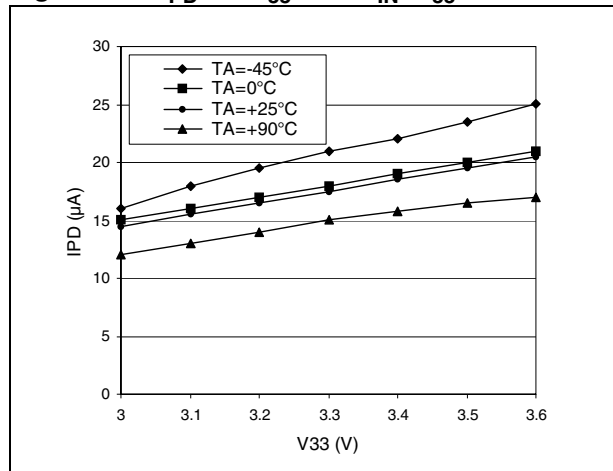

Figure 20. I_{PD} vs. V_{33} with $V_{IN}=V_{33}$



Output driving current

Subject to general operating conditions for V_{33} and T_A unless otherwise specified.

Table 28. Output driving current

I/O Type	Symbol	Parameter	Conditions	Min	Max	Unit
Standard	$V_{OL}^{1)}$	Output low level voltage for an I/O pin when 8 pins are sunk at same time (see Figure 21)	$I_{IO}=+4mA$		0.4	V
	$V_{OH}^{2)}$	Output high level voltage for an I/O pin when 4 pins are sourced at same time (see Figure 21 and Figure 23)	$I_{IO}=-4mA$	$V_{33}-0.8$		
High Current	$V_{OL}^{1)}$	Output low level voltage for an I/O pin when 8 pins are sunk at same time (see Figure 21)	$I_{IO}=+8mA$		0.4	
	$V_{OH}^{2)}$	Output high level voltage for an I/O pin when 4 pins are sourced at same time (see Figure 21 and Figure 23)	$I_{IO}=-8mA$	$V_{33}-0.8$		

Notes:

1. The I_{IO} current sunk must always respect the absolute maximum rating specified in [Table 10](#) and the sum of I_{IO} (I/O ports and control pins) must not exceed I_{VSS} .
2. The I_{IO} current sourced must always respect the absolute maximum rating specified in [Table 10](#) and the sum of I_{IO} (I/O ports and control pins) must not exceed I_{V33} .

Figure 21. Typical V_{OL} and V_{OH} at $V_{33}=3.3V$ (High current ports)

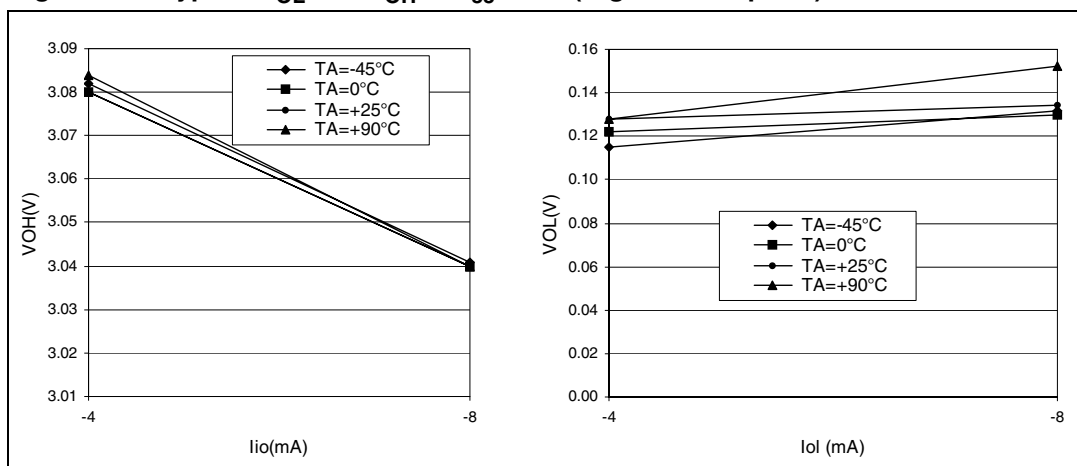

Figure 22. Typical V_{OL} vs. V_{33}

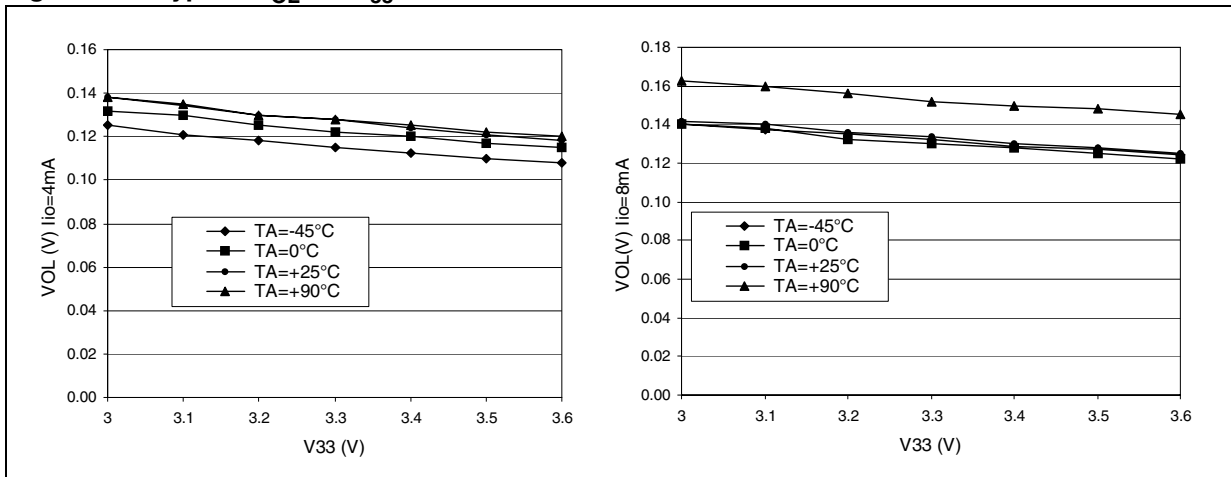
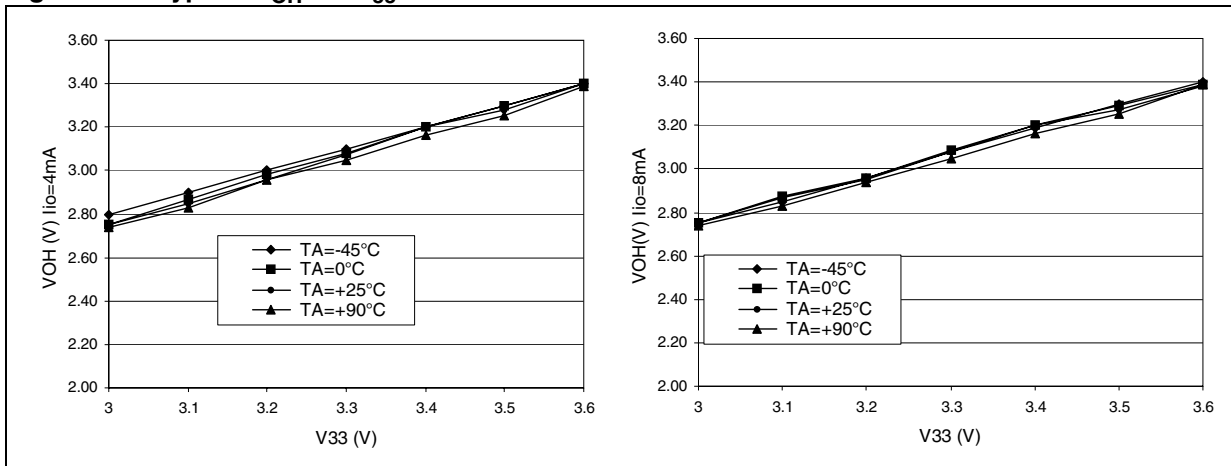

Figure 23. Typical V_{OH} vs. V_{33}



$\overline{\text{RSTIN}}$ pin

The $\overline{\text{RSTIN}}$ pin input driver is CMOS. A permanent pull-up is present which is the same as R_{PU} (see [Table 27 on page 50](#))

Subject to general operating conditions for V_{33} and T_A unless otherwise specified.

Table 29. $\overline{\text{RESET}}$ pin characteristics

Symbol	Parameter	Conditions	Min	Typ ¹⁾	Max	Unit
$V_{\text{IL}}(\overline{\text{RSTINn}})$	$\overline{\text{RSTIN}}$ Input low level voltage ¹⁾				0.8	V
$V_{\text{IH}}(\overline{\text{RSTINn}})$	$\overline{\text{RSTIN}}$ Input high level voltage ¹⁾		2			
$V_{\text{F}}(\overline{\text{RSTINn}})$	$\overline{\text{RSTIN}}$ Input filtered pulse ²⁾				500	ns
$V_{\text{NF}}(\overline{\text{RSTINn}})$	$\overline{\text{RSTIN}}$ Input not filtered pulse ²⁾		1.2			μs

Notes:

1. Data based on characterization results, not tested in production.
- 2) Data guaranteed by design, not tested in production.

Figure 24. Recommended $\overline{\text{RSTIN}}$ pin protection.¹⁾

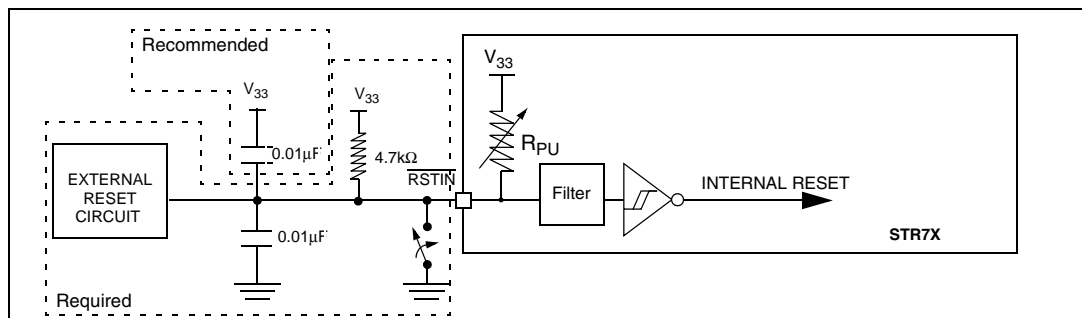

Notes:

1. The R_{PU} pull-up equivalent resistor is based on a resistive transistor (corresponding I_{PU} current characteristics described in [Figure 18](#)).
2. The reset network protects the device against parasitic resets.
3. The user must ensure that the level on the $\overline{\text{RSTIN}}$ pin can go below the $V_{\text{IL}}(\overline{\text{RSTINn}})$ max. level specified in [Table 29](#). Otherwise the reset will not be taken into account internally.

5.3.6 TIM timer characteristics

Subject to general operating conditions for V_{33} , f_{MCLK} , and T_A unless otherwise specified.

Refer to [Section 5.3.5: I/O port pin characteristics on page 50](#) for more details on the input/output alternate function characteristics (output compare, input capture, external clock, PWM output...).

Table 30. TIM characteristics

Symbol	Parameter	Conditions	Min	Typ	Max	Unit
$t_{\text{w}}(\text{ICAP})_{\text{in}}$	Input capture pulse time		2			$t_{\text{CK_TIM}}$

Table 30. TIM characteristics

Symbol	Parameter	Conditions	Min	Typ	Max	Unit
t _{res(TIM)}	Timer resolution time		1			t _{PCLK2}
		f _{PCLK2} = 30MHz	33.3			ns
f _{EXT}	Timer external clock frequency	f _{CK_TIM(MAX)} = f _{MCLK}	0		f _{CK_TIM} /4	MHz
		f _{CK_TIM} = f _{MCLK} = 60MHz	0		15	MHz
Res _{TIM}	Timer resolution				16	bit
t _{COUNTER}	16-bit Counter clock period when internal clock is selected		1		65536	t _{PCLK}
		f _{PCLK2} = 30MHz	0.033		2184	µs
T _{MAX_COUNT}	Maximum Possible Count				65536x 65536	t _{PCLK}
		f _{PCLK2} = 30MHz			143.1	s

5.3.7 EMI - External Memory Interface

Subject to general operating conditions for V_{DD}, f_{HCLK}, and T_A unless otherwise specified.

The tables below use a variable which is derived from the EMI_BCONn registers (described in the STR71x Reference Manual) and represents the special characteristics of the programmed memory cycle.

Table 31. EMI general characteristics

Symbol	Parameter	Value
t _{MCLK}	CPU clock period	1 / f _{MCLK}
t _C	Memory cycle time wait states	t _{MCLK} × (1 + [C_LENGTH])

Table 32. EMI Read Operation

Symbol	Parameter	Test Conditions	Value			Unit
			Min ¹⁾	Typ	Max ¹⁾	
t _{RCR}	Read to CSn Removal Time	MCLK=50 MHz 4 wait states 50 pf load on all pins	19	t _{MCLK}	21	ns
t _{RP}	Read Pulse Time		98	t _C	100	ns
t _{RDS}	Read Data Setup Time		22			ns
t _{RDH}	Read Data Hold Time		0			ns
t _{RAS}	Read Address Setup Time		27	1.5*t _M CLK	33	ns
t _{RAH}	Read Address Hold Time		0.65		2	ns
t _{RAT}	Read Address Turnaround Time		1.9		3.25	ns
t _{RRT}	RDn Turnaround Time		20	t _{MCLK}	21	ns

See [Figure 25](#), [Figure 26](#), [Figure 27](#) and [Figure 28](#) for related timing diagrams.

1. Data based on characterisation results, not tested in production.

Table 33. EMI Write Operation

Symbol	Parameter	Test Conditions	Value			Unit
			Min ¹⁾	Typ	Max ¹⁾	
t _{WCR}	WEn to CSn Removal Time	MCLK=50 MHz 3 wait states 50 pf load on all pins	20	t _{MCLK}	22.5	ns
t _{WP}	Write Pulse Time		77.5	t _C	80	ns
t _{WDS1}	Write Data Setup Time 1		97	t _C + t _{MCLK}	100	ns
t _{WDS2}	Write Data Setup Time 2		77	t _C	80	ns
t _{WDH}	Write Data Hold Time		20	t _{MCLK}	23	ns
t _{WAS}	Write Address Setup Time		27	1.5*t _{MCLK}	33	ns
t _{WAH}	Write Address Hold Time		0.6		3	ns
t _{WAT}	Write Address Turnaround Time		1.75		4.1	ns
t _{WWT}	WEn Turnaround Time		20	t _{MCLK}	23	ns

See [Figure 29](#), [Figure 30](#), [Figure 31](#) and [Figure 32](#) for related timing diagrams.

1. Data based on characterisation results, not tested in production.

Figure 25. Read Cycle Timing: 16-bit READ on 16-bit Memory

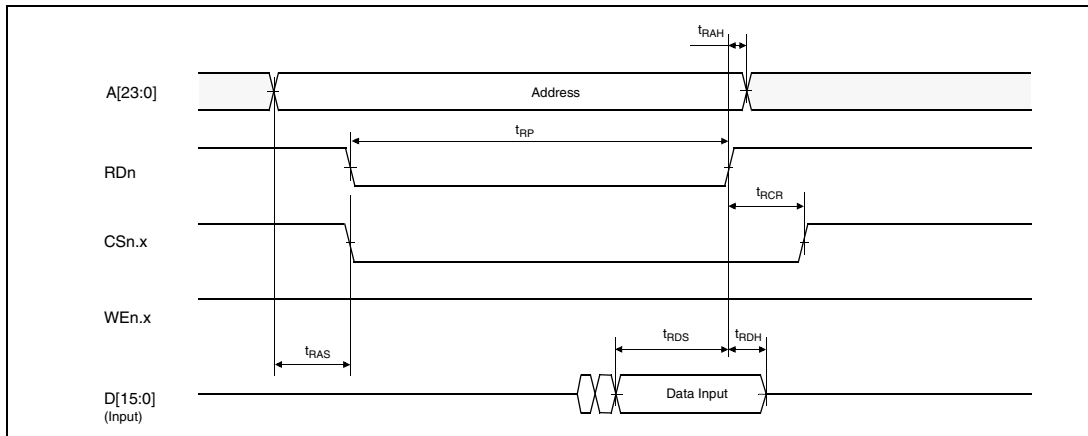
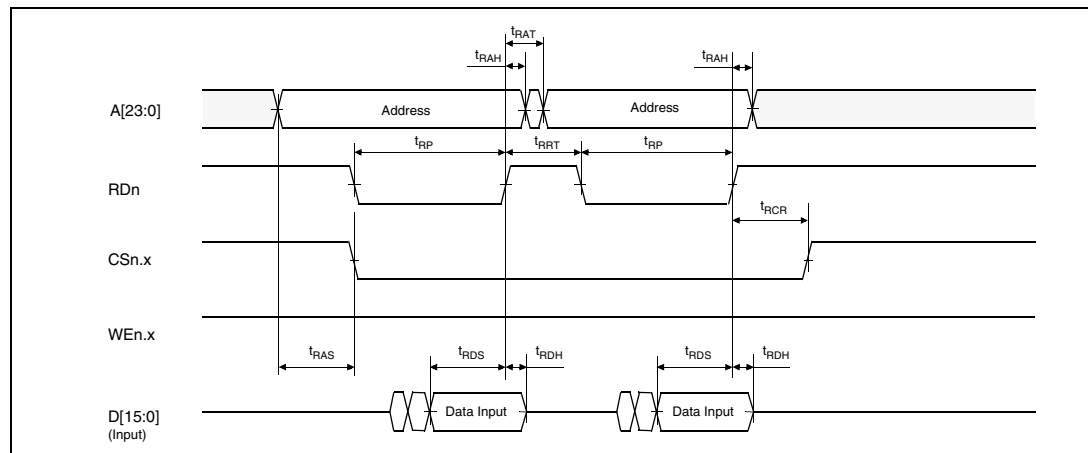

Figure 26. Read Cycle Timing: 32-bit READ on 16-bit Memory



See [Table 32](#) for read timing data.

Figure 27. Read Cycle Timing: 16-bit READ on 8-bit Memory

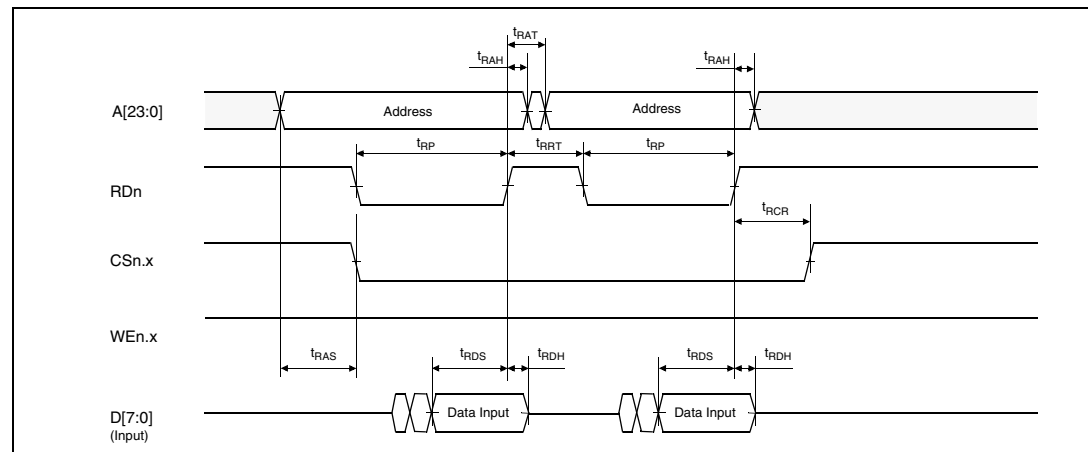
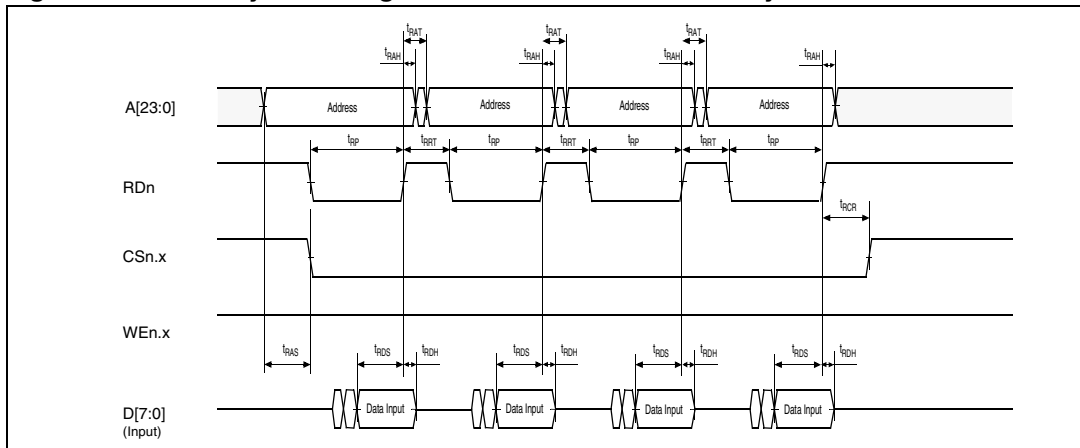

Figure 28. Read Cycle Timing: 32-bit READ on 8-bit Memory



See [Table 32](#) for read timing data.

Figure 29. Write Cycle Timing: 16-bit WRITE on 16-bit Memory

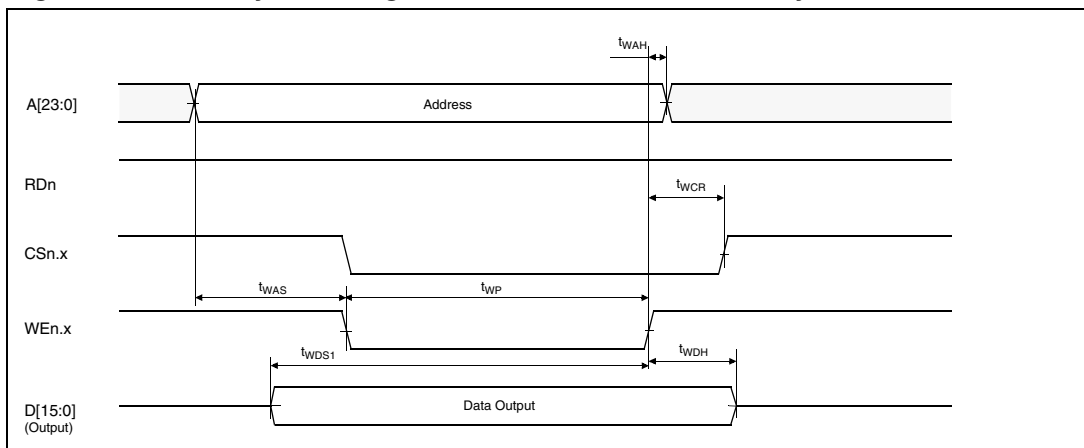
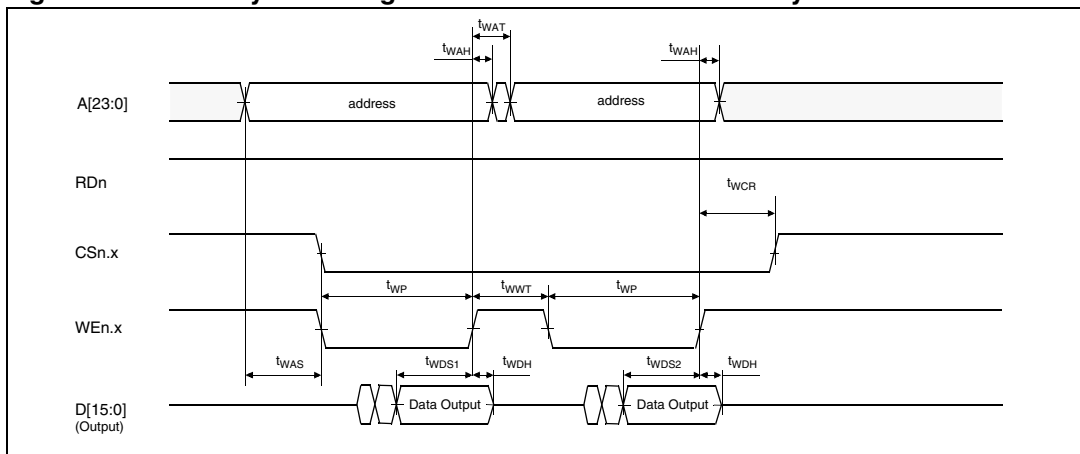

Figure 30. Write Cycle Timing: 32-bit WRITE on 16-bit Memory



See [Table 42](#) for write timing data.

Figure 31. Write Cycle Timing: 16-bit WRITE on 8-bit Memory

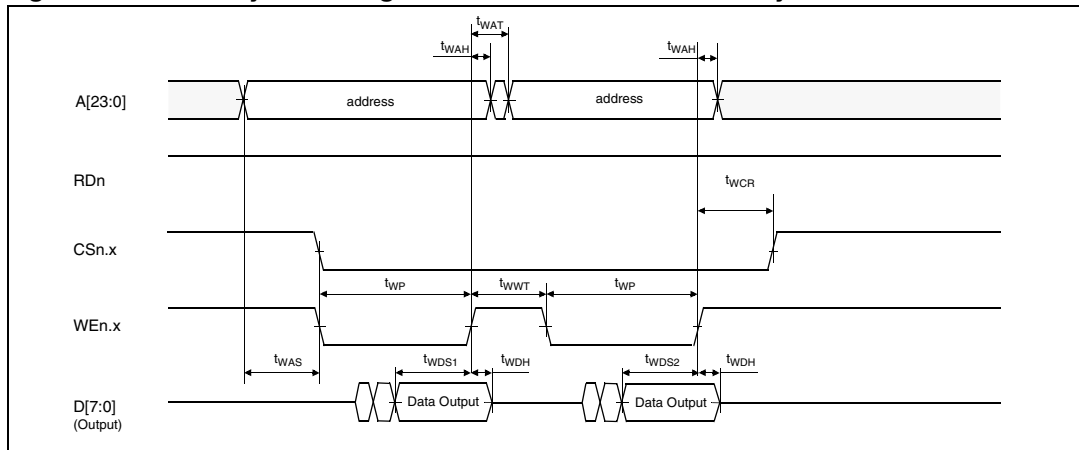
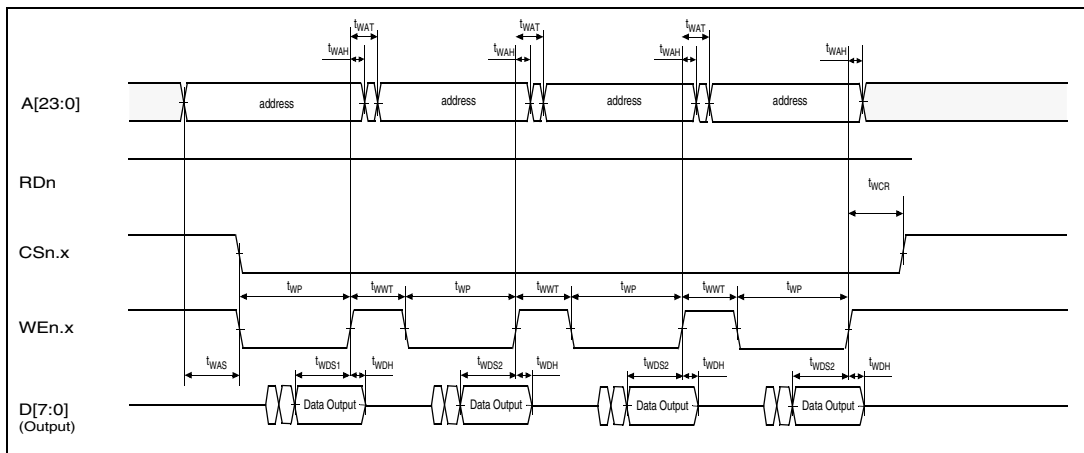

Figure 32. Write Cycle Timing: 32-bit WRITE on 8-bit Memory



See [Table 33](#) for write timing data.

5.3.8 Communications interfaces

I²C - Inter IC Control Interface

Subject to general operating conditions for V_{33} , f_{PCLK1} , and T_A unless otherwise specified.

The STR7 I²C interface meets the requirements of the Standard I²C communication protocol described in the following table with the restriction mentioned below:

Note: **Restriction:** The I/O pins which SDA and SCL are mapped to are not “True” Open-Drain: when configured as open-drain, the PMOS connected between the I/O pin and V_{33} is disabled, but it is still present. Also, there is a protection diode between the I/O pin and V_{33} . Consequently, when using this I²C in a multi-master network, it is not possible to power off the STR7X while some another I²C master node remains powered on: otherwise, the STR7X will be powered by the protection diode.

Refer to I/O port characteristics for more details on the input/output alternate function characteristics (SDA and SCL).

Table 34. I2C Characteristics

Symbol	Parameter	Standard mode I ² C		Fast mode I ² C ⁵⁾		Unit
		Min ¹⁾	Max ¹⁾	Min ¹⁾	Max ¹⁾	
$t_{w(SCLL)}$	SCL clock low time	4.7		1.3		μ s
$t_{w(SCLH)}$	SCL clock high time	4.0		0.6		
$t_{su(SDA)}$	SDA setup time	250		100		ns
$t_{h(SDA)}$	SDA data hold time	0 ³⁾		0 ²⁾	900 ³⁾	
$t_{r(SDA)}$ $t_{r(SCL)}$	SDA and SCL rise time		1000	20+0.1C _b	300	
$t_{f(SDA)}$ $t_{f(SCL)}$	SDA and SCL fall time		300	20+0.1C _b	300	
$t_{h(STA)}$	START condition hold time	4.0		0.6		μ s
$t_{su(STA)}$	Repeated START condition setup time	4.7		0.6		
$t_{su(STO)}$	STOP condition setup time	4.0		0.6		μ s
$t_{w(STO:STA)}$	STOP to START condition time (bus free)	4.7		1.3		μ s
C_b	Capacitive load for each bus line		400		400	pF

Notes:

1. Data based on standard I²C protocol requirement, not tested in production.
2. The device must internally provide a hold time of at least 300ns for the SDA signal in order to bridge the undefined region of the falling edge of SCL.
3. The maximum hold time of the START condition has only to be met if the interface does not stretch the low

- period of SCL signal.
- 4. Measurement points are done at CMOS levels: $0.3 \times V_{DD}$ and $0.7 \times V_{DD}$.
- 5. f_{PCLK1} , must be at least 8MHz to achieve max fast I²C speed (400kHz).
- 6. The following table gives the values to be written in the I2CCCR register to obtain the required I²C SCL line frequency.

Figure 33. Typical Application with I²C Bus and Timing Diagram⁴⁾

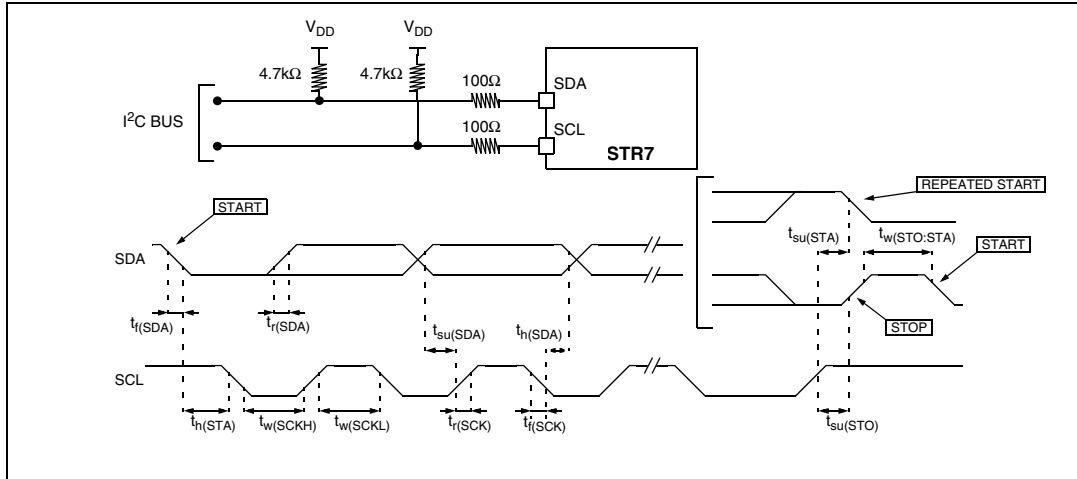

Table 35. SCL Frequency Table ($f_{PCLK1}=8\text{ MHz}, V_{33} = 3.3\text{ V}$)

f _{SCL} (kHz)	I2CCCR Value
	R _P =4.7kΩ
400	83
300	85h
200	8Ah
100	24h
50	4Ch
20	C4h

Legend:

R_P = External pull-up resistance

f_{SCL} = I²C speed

NA = Not achievable

Note: For speeds around 200 kHz, achieved speed can have ±5% tolerance

For other speed ranges, achieved speed can have ±2% tolerance

The above variations depend on the accuracy of the external components used.

BSPI - Buffered Serial Peripheral Interface

Subject to general operating conditions for V_{DD} , T_A and f_{PCLK} , unless otherwise specified.

Refer to [I/O port pin characteristics on page 50](#) for more details on the input/output alternate function characteristics (\overline{SS} , SCK, MOSI, MISO).

Table 36. BSPI characteristics

Symbol	Parameter	Conditions	Min	Max	Unit
f_{SCK} $1/t_{c(SCK)}$	SPI clock frequency	Master	$f_{PCLK}/254$	$f_{PCLK}/6$ 5.5	MHz
		Slave	0	$f_{PCLK}/8$ 3.3	
$t_r(SCK)$ $t_f(SCK)$	SPI clock rise and fall time	capacitive charge $C=50$ pF		14	ns
$t_{su}(\overline{SS})^{(1)}$	\overline{SS} setup time	Slave	0		
$t_h(\overline{SS})^{(1)}$	\overline{SS} hold time	Slave	0		
$t_w(SCKH)^{(1)}$ $t_w(SCKL)^{(1)}$	SCK high and low time	Master $f_{PCLK}=33$ MHz, presc = 6	73		
$t_{su(MI)}^{(1)}$ $t_{su(SI)}^{(1)}$	Data input setup time	Master Slave	7 0		
$t_h(MI)^{1(2)}$ $t_h(SI)^{1(2)}$	Data input hold time	Master Slave	$1 \times t_{PCLK}$ $2 \times t_{PCLK}$		
$t_h(MI)^{(1)}$ $t_h(SI)^{(1)}$	Data input hold time	Master $f_{PCLK}=33$ MHz Slave $f_{PCLK}=33$ MHz	30 60		
$t_{a(SO)}^{1(3)}$	Data output access time	Slave	0	$1.5 \times t_{PCLK} + 42$	
		Slave $f_{PCLK}=33$ MHz	0	87	
$t_{dis(SO)}^{(1)(4)}$	Data output disable time	Slave	0	42	
$t_v(SO)^{(1)(2)}$	Data output valid time	Slave (after enable edge)		$3 \times t_{PCLK} + 45$	
		$f_{PCLK}=33$ MHz		135	
$t_h(SO)^{(1)}$	Data output hold time	Slave (after enable edge)	0		
$t_v(MO)^{(1)(2)}$	Data output valid time	Master (after enable edge)		$2 \times t_{PCLK} + 12$	
		$f_{PCLK}=33$ MHz		72	
$t_h(MO)^{(1)}$	Data output hold time	Master (after enable edge)	0		

1. Data based on design simulation and/or characterisation results, not tested in production.
2. Depends on f_{PCLK} . For example, if $f_{PCLK}=8$ MHz, then $t_{PCLK} = 1/f_{PCLK} = 125$ ns and $t_v(MO) = 255$ ns.
3. Min. time is the minimum time to drive the output and the max. time is the maximum time to validate the data.
4. Min time is the minimum time to invalidate the output and the max time is the maximum time to put the data in Hi-Z.

Figure 34. SPI Slave Timing Diagram with CPHA=0 (a)

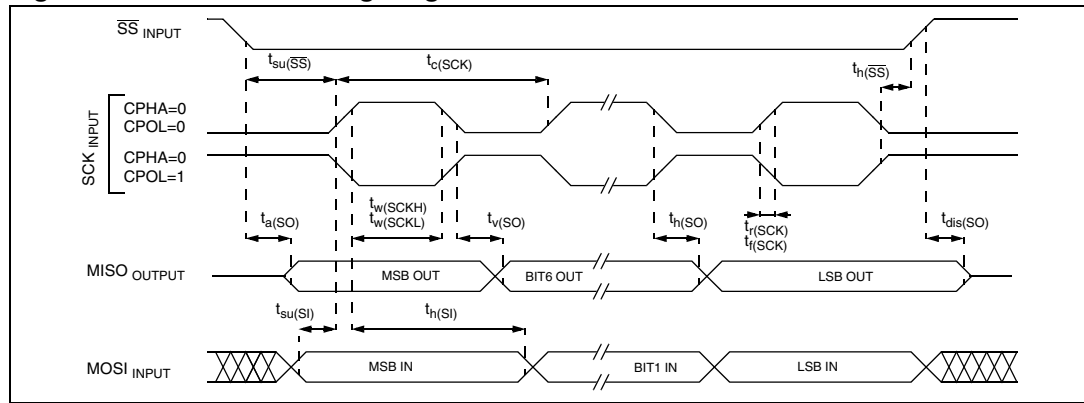

Figure 35. SPI Slave Timing Diagram with CPHA=1(a)

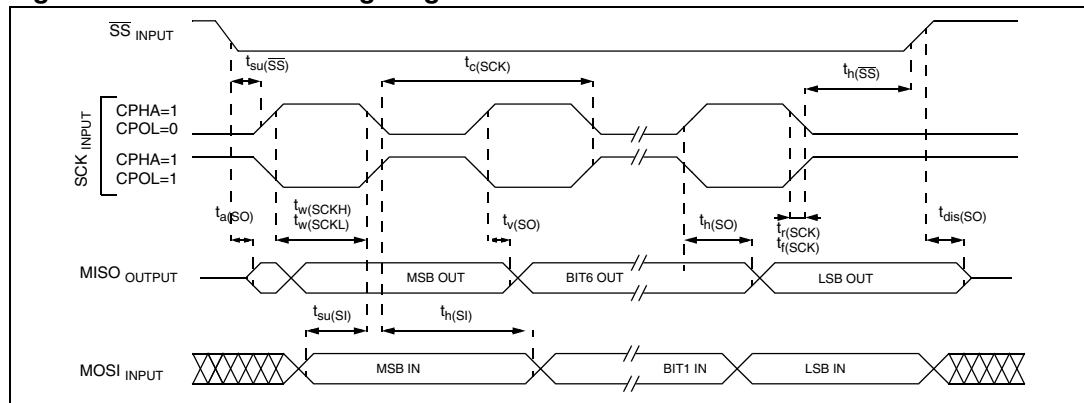
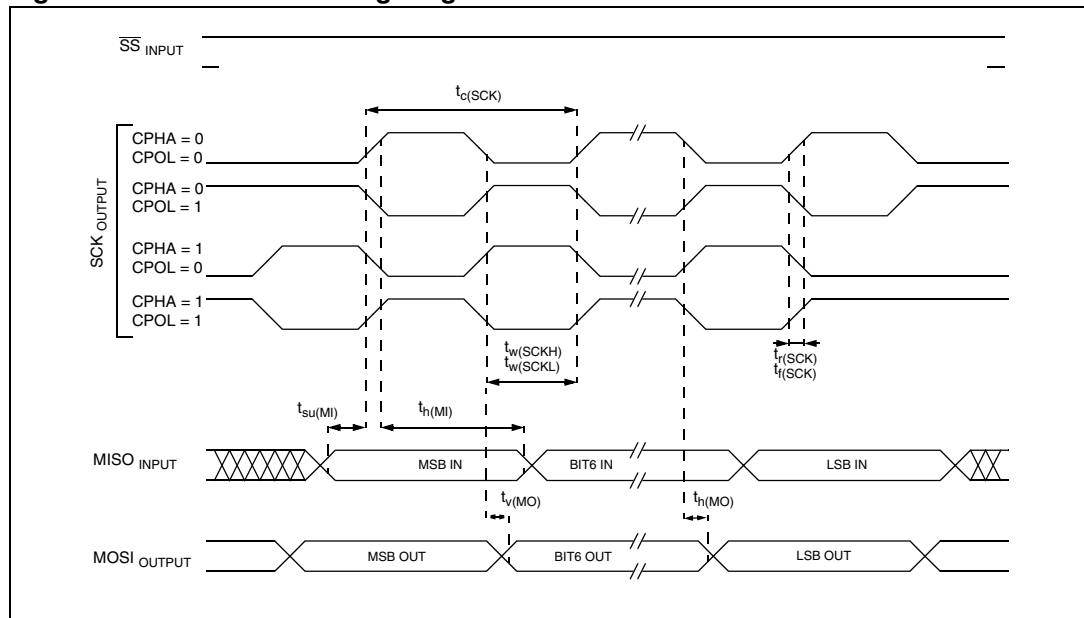

Figure 36. SPI Master Timing Diagram(a)



a. Measurement points are done at CMOS levels: $0.3 \times V_{33}$ and $0.7 \times V_{33}$

USB Characteristics

The USB interface is USB-IF certified (Low Speed and Full Speed).

5.3.9 ADC characteristics

Subject to general operating conditions for AV_{DD} , f_{PCLK2} , and T_A unless otherwise specified.

Table 37. ADC characteristics

Symbol	Parameter	Conditions	Min	Typ ¹⁾	Max	Unit
f_{MOD}	Modulator Oversampling frequency				2.1	MHz
V_{AIN}	Conversion voltage range ²⁾³⁾		0		2.5	V
I_{lkg}	Negative input leakage current on analog pins	$V_{IN} < V_{SS}$, $ I_{IN} < 400\mu A$ on adjacent analog pin		5	6	μA
PBR	Passband Ripple				0.1	dB
SINAD	S/N and Distortion		56	63		dB
THD	Total Harmonic Distortion		60	74		dB
Z_{IN}	Input Impedance	$f_{MOD} = 2\text{ MHz}$	1			$M\Omega$
C_{ADC}	Internal sample and hold capacitor				3.2	pF
t_{CONV}	Total Conversion time (including sampling time)		4096/ f_{MOD} (max)			
I_{ADC}	Normal mode	$T_A = 27\text{ }^\circ C$		2.5	3.0	mA
	Standby mode	$T_A = 27\text{ }^\circ C$			1	μA

Notes:

1. Unless otherwise specified, typical data are based on $T_A=25^\circ C$ and $AV_{DD}-AV_{SS}=3.3V$. They are given only as design guidelines and are not tested.
2. Any added external serial resistor will downgrade the ADC accuracy (especially for resistance greater than $10k\Omega$). Data based on characterization results, not tested in production.
3. Calibration is needed once after each power-up.

Table 38. ADC Accuracy with $f_{PCLK2} = 20\text{MHz}$, $f_{ADC}=10\text{MHz}$, $AV_{DD}=3.3\text{V}$

Symbol	Parameter	Conditions	Min	Typ	Max	Unit
ADC_DATA(0V)	Converted code when AIN=0V ¹⁾		2370		2565	Decimal code
ADC_DATA(2.5V)	Converted code when AIN=2.5V ¹⁾		1480		1680	
VCM	Center voltage of Sigma-Delta Modulator ¹⁾		1.23	1.25	1.30	V
TUE	Total unadjusted error	In this type of ADC, calibration is necessary to correct gain error and offset errors. Once calibrated, the TUE is limited to the ILE.				
E _D	Differential linearity error ¹⁾			1.96	2.19	LSB
E _L	Integral linearity error ¹⁾			2.36	3.95	

- Data based on characterisation, not tested in production.
ADC Accuracy vs. Negative Injection Current: Injecting negative current on any of the standard (non-robust) analog input pins should be avoided as this significantly reduces the accuracy of the conversion being performed on another analog input. It is recommended to add a Schottky diode (pin to ground) to standard analog pins which may potentially inject negative current. The effect of negative injection current on robust pins is specified in [Section 5.3.5](#).
 Any positive injection current within the limits specified for $I_{INJ(PIN)}$ and $\Sigma I_{INJ(PIN)}$ in [Section 5.3.5](#) does not affect the ADC accuracy.

Figure 37. ADC Accuracy Characteristics

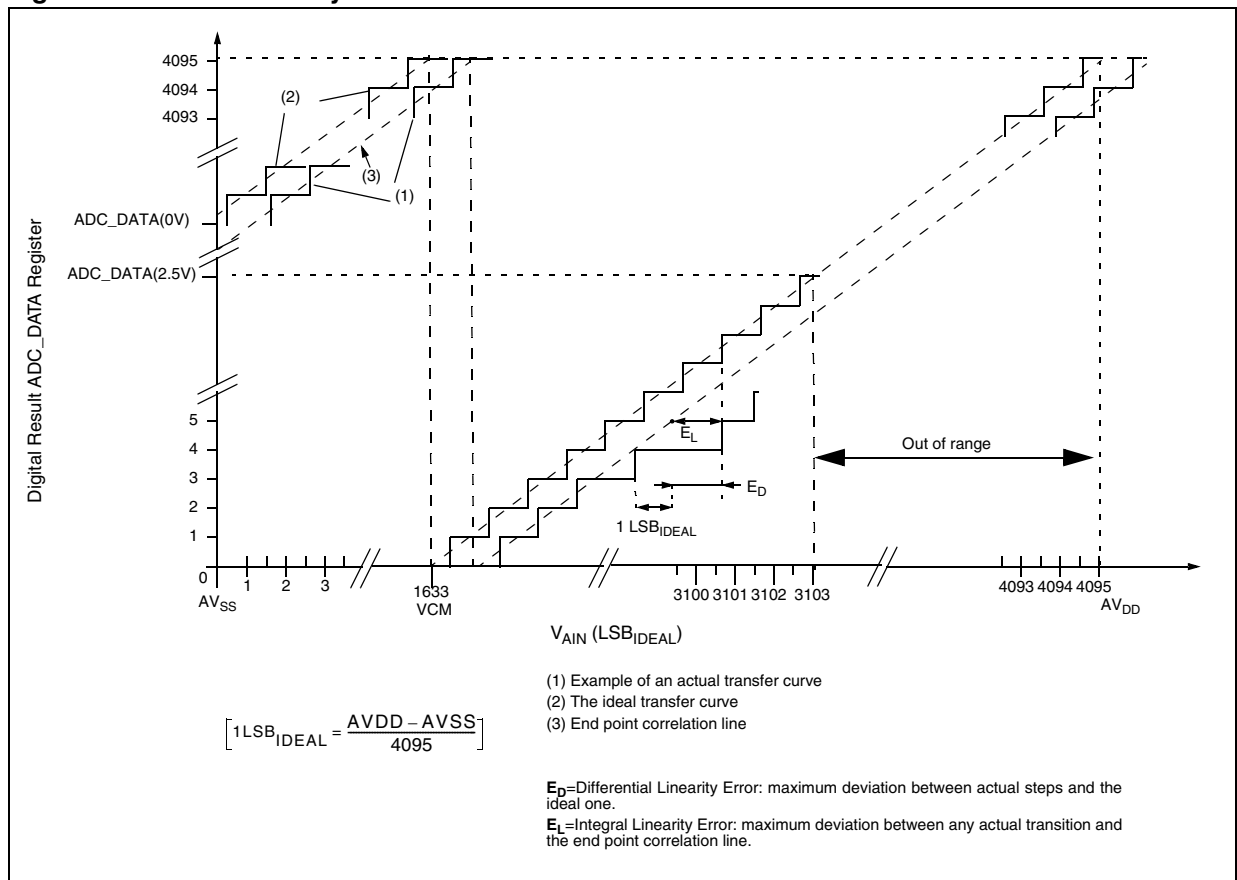

Analog power supply and reference pins

The AV_{DD} and AV_{SS} pins are the analog power supply of the A/D converter cell. They act as the high and low reference voltages for the conversion.

Separation of the digital and analog power pins allow board designers to improve A/D performance. Conversion accuracy can be impacted by voltage drops and noise in the event of heavily loaded or badly decoupled power supply lines (see: [General PCB design guidelines](#)).

General PCB design guidelines

To obtain best results, some general design and layout rules should be followed when designing the application PCB to shield the noise-sensitive, analog physical interface from noise-generating CMOS logic signals.

- Use separate digital and analog planes. The analog ground plane should be connected to the digital ground plane via a single point on the PCB.
- Filter power to the analog power planes. It is recommended to connect capacitors, with good high frequency characteristics, between the power and ground lines, placing 0.1 μ F and optionally, if needed 10pF capacitors as close as possible to the STR7 power supply pins and a 1 to 10 μ F capacitor close to the power source (see [Figure 38](#)).
- The analog and digital power supplies should be connected in a star network. Do not use a resistor, as AV_{DD} is used as a reference voltage by the A/D converter and any resistance would cause a voltage drop and a loss of accuracy.
- Properly place components and route the signal traces on the PCB to shield the analog inputs. Analog signals paths should run over the analog ground plane and be as short as possible. Isolate analog signals from digital signals that may switch while the analog inputs are being sampled by the A/D converter. Do not toggle digital outputs near the A/D input being converted.

Software filtering of spurious conversion results

For EMC performance reasons, it is recommended to filter A/D conversion outliers using software filtering techniques.

Figure 38. Power Supply Filtering

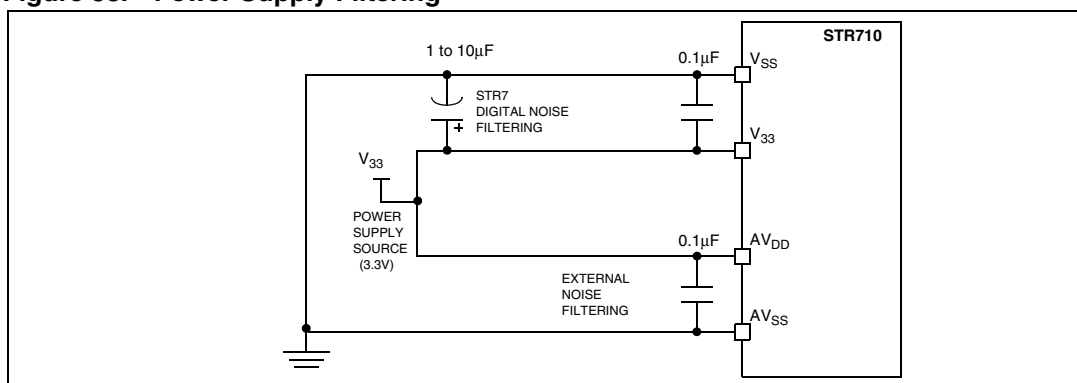

6 Package characteristics

6.1 Package mechanical data

Figure 39. 64-Pin Low Profile Quad Flat Package (10x10)

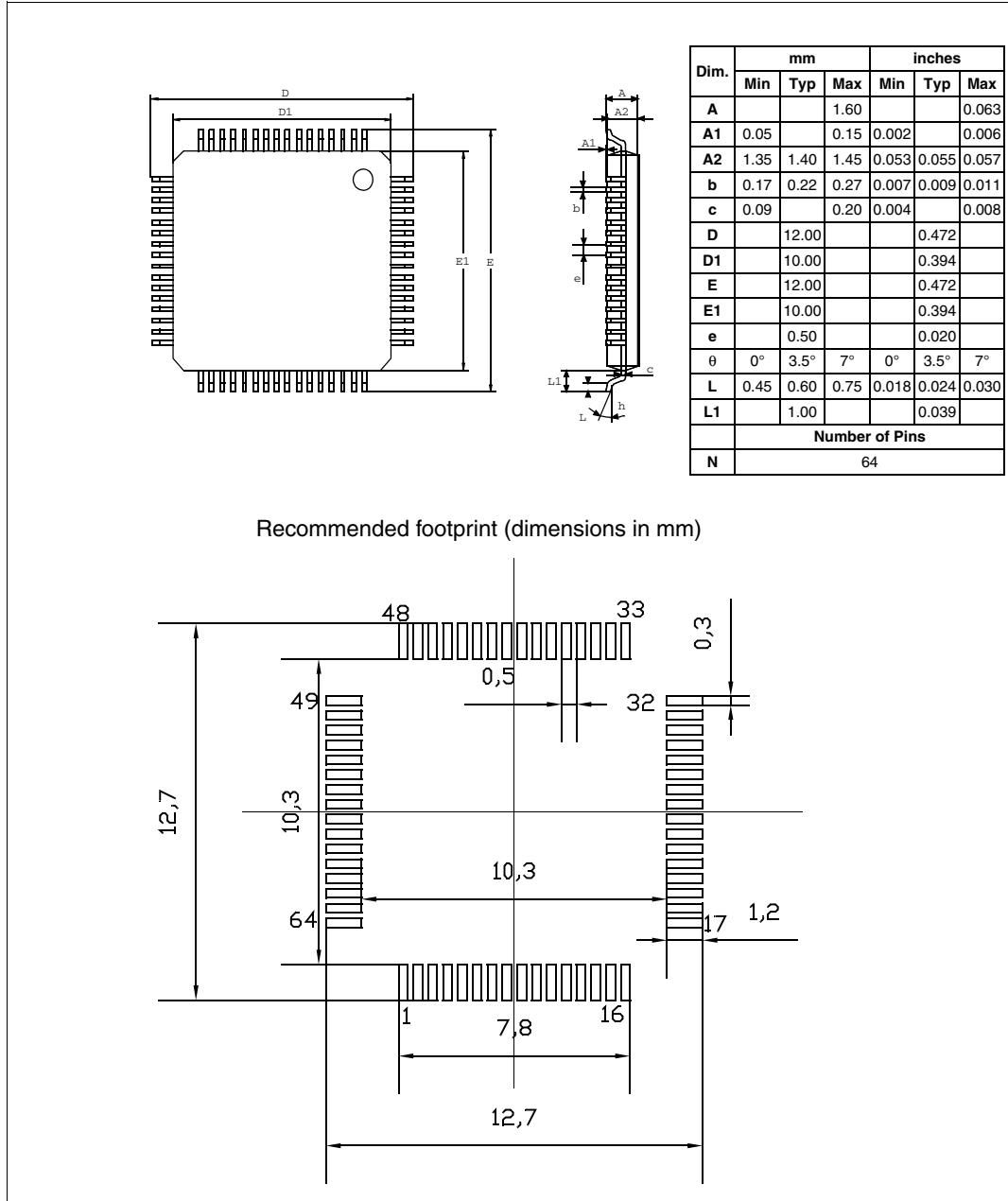

Figure 40. 144-Pin Low profile Quad Flat Package

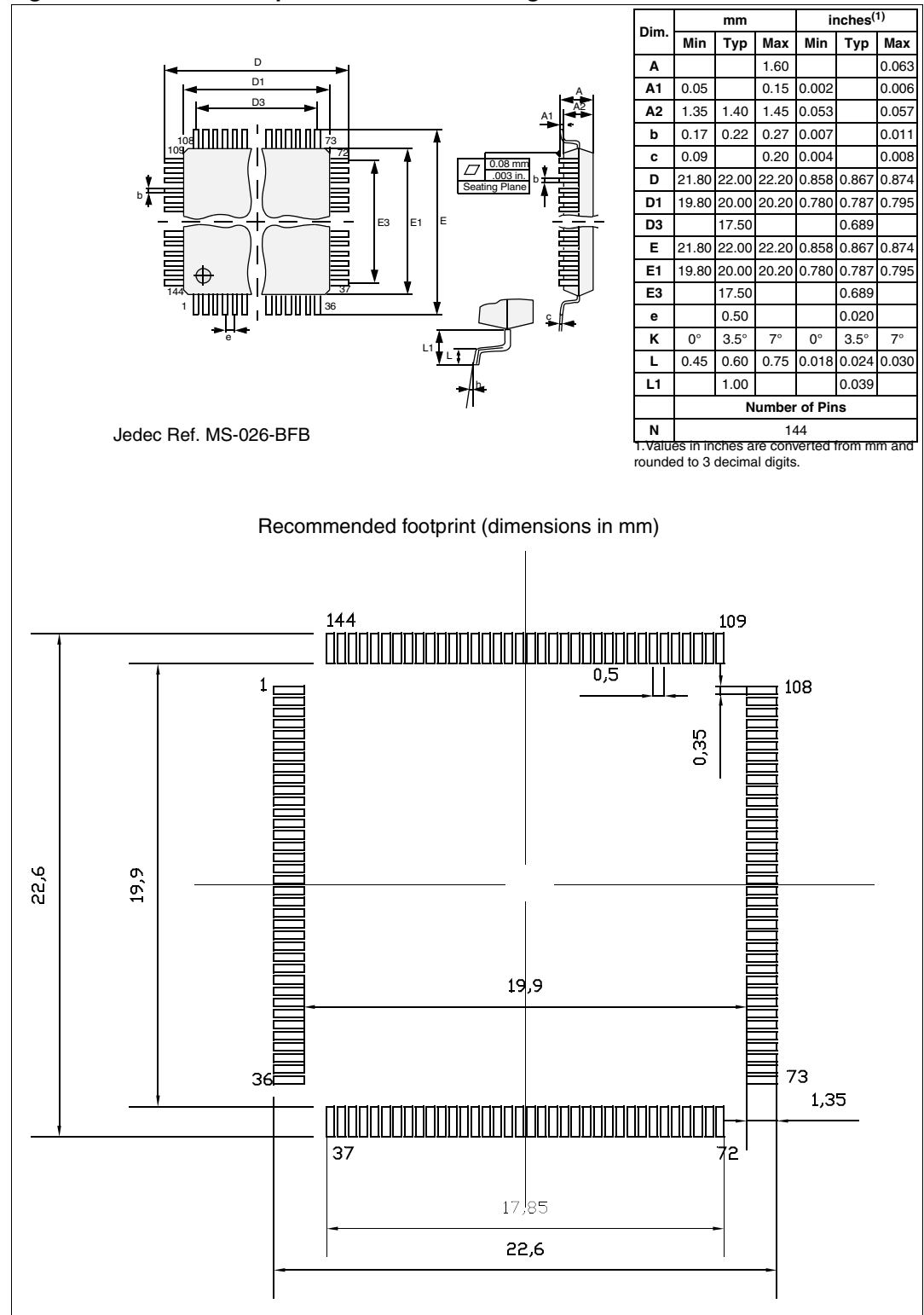

Figure 41. 64-Low Profile Fine Pitch Ball Grid Array Package

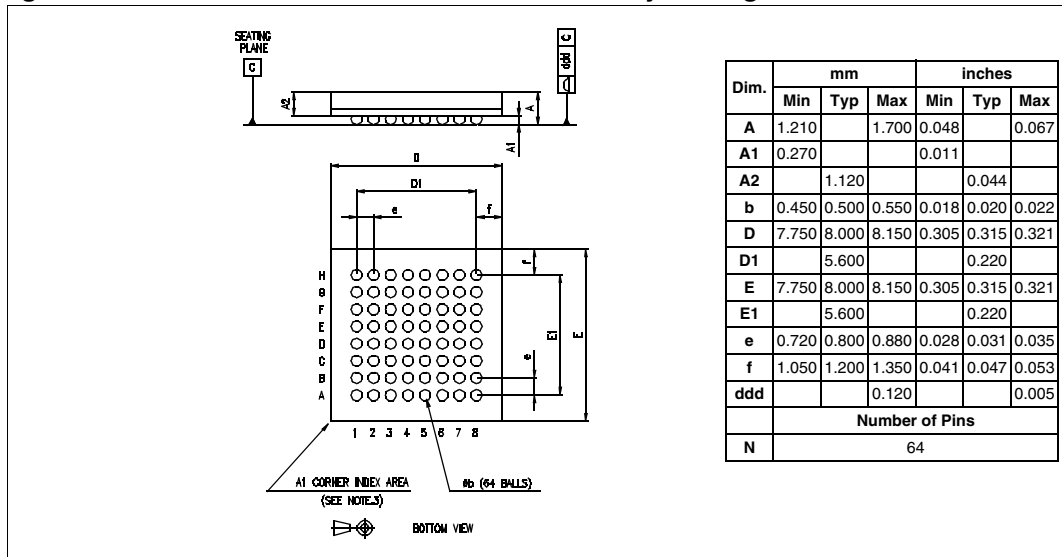

Figure 42. 144-Low Profile Fine Pitch Ball Grid Array Package

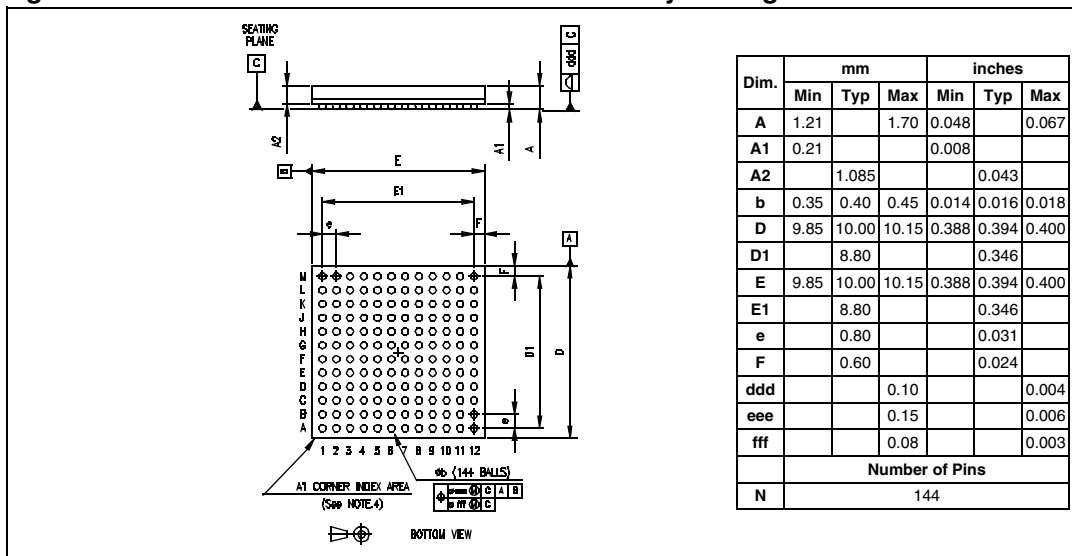
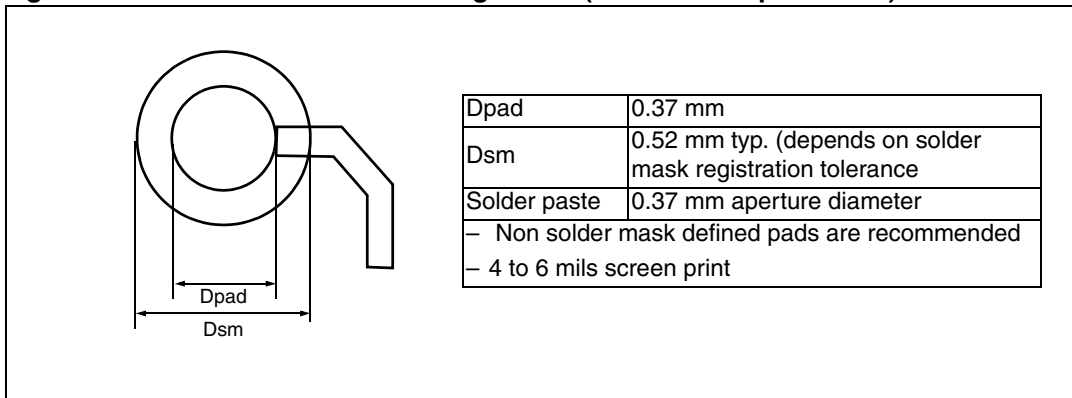

Figure 43. Recommended PCB Design rules (0.80/0.75mm pitch BGA)



6.2 Thermal characteristics

The average chip-junction temperature, T_J , in degrees Celsius, may be calculated using the following equation:

$$T_J = T_A + (P_D \times \Theta_{JA}) \quad (1)$$

Where:

- T_A is the Ambient Temperature in °C,
- Θ_{JA} is the Package Junction-to-Ambient Thermal Resistance, in °C/W,
- P_D is the sum of P_{INT} and $P_{I/O}$ ($P_D = P_{INT} + P_{I/O}$),
- P_{INT} is the product of I_{DD} and V_{DD} , expressed in Watts. This is the Chip Internal Power.

$P_{I/O}$ represents the Power Dissipation on Input and Output Pins;

Most of the time for the application $P_{I/O} < P_{INT}$ and can be neglected. On the other hand, $P_{I/O}$ may be significant if the device is configured to drive continuously external modules and/or memories.

An approximate relationship between P_D and T_J (if $P_{I/O}$ is neglected) is given by:

$$P_D = K / (T_J + 273^\circ\text{C}) \quad (2)$$

Therefore (solving equations 1 and 2):

$$K = P_D \times (T_A + 273^\circ\text{C}) + \Theta_{JA} \times P_D^2 \quad (3)$$

where:

K is a constant for the particular part, which may be determined from equation (3) by measuring P_D (at equilibrium) for a known T_A . Using this value of K , the values of P_D and T_J may be obtained by solving equations (1) and (2) iteratively for any value of T_A .

Table 39. Thermal characteristics

Symbol	Parameter	Value	Unit
Θ_{JA}	Thermal Resistance Junction-Ambient LQFP 144 - 20 x 20 mm / 0.5 mm pitch	42	°C/W
Θ_{JA}	Thermal Resistance Junction-Ambient LQFP 64 - 10 x 10 mm / 0.5 mm pitch	45	°C/W
Θ_{JA}	Thermal Resistance Junction-Ambient LFBGA 64 - 8 x 8 x 1.7mm	58	°C/W
Θ_{JA}	Thermal Resistance Junction-Ambient LFBGA 144 - 10 x 10 x 1.7mm	50	°C/W

7 Product history

There are three versions of the STR710F series products. All versions are functionally identical and differ only with the points listed below.

Version "A" was the first version produced and delivered. Version "Z" was the second in production replacing version "A". Version "Z" has lower power consumption in STOP mode.

Version "X" is the latest introduced.

Marking

The difference between versions is visible on the marking of the product as shown in the four examples in [Figure 44](#) through [Figure 47](#).

Figure 44. LQFP144 STR710 version "A"



Figure 45. LQFP64 STR712 version "Z"



Figure 46. BGA144 STR710 version “Z”

Figure 47. BGA64 STR711 version “X”

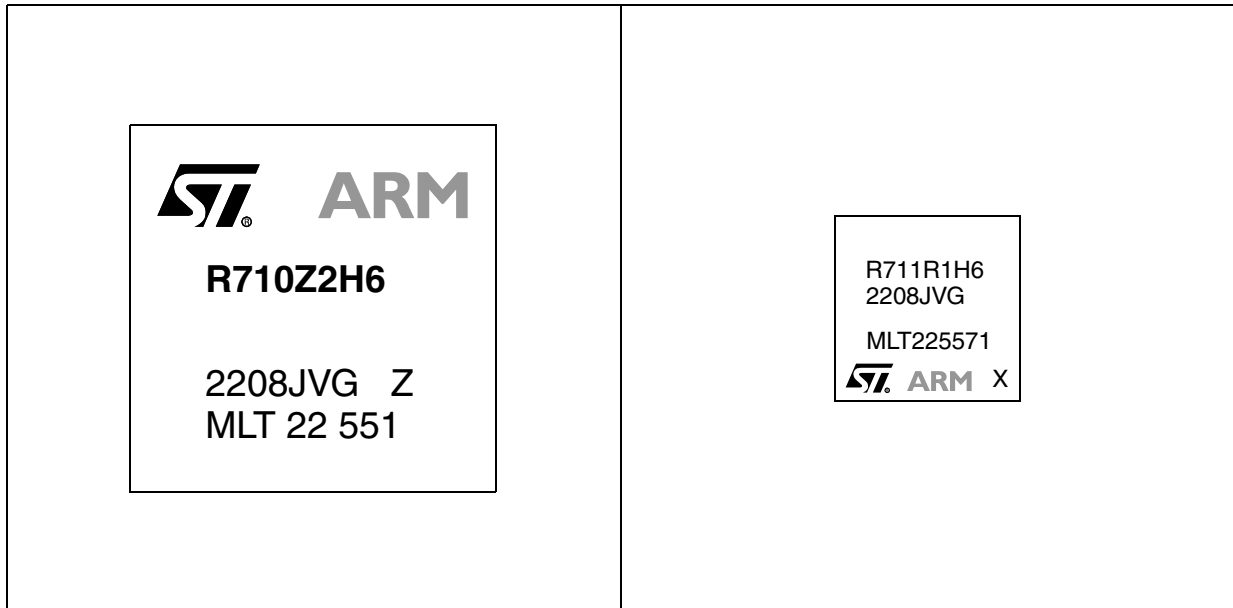

Table 40. A, Z and X version differences

Feature	A version	Z version	X version
ARM7TDMI core device Identification (ID) code register (see ARM7TDMI Technical Reference Manual)	Version bits [31:28] = 0001	Version bits [31:28] = 0010	Version bits [31:28] = 0010
Low power mode consumption in STOP mode at 25 °C	Not guaranteed Typical 49 µA	50 µA maximum at 25°C. Less than 30 µA at 25 °C for 99.730020% of parts	Same as Z.
SC.DATA pin	Not TRUE open drain When addressing 5V cards, the SCDATA Line must be connected to an open drain buffer.		Pin P0.10/U1.RX/U1.TX/SC.DATA has been modified to offer TRUE OPEN DRAIN functionality when in SmartCard mode. When addressing 5V cards, the SCDATA line can now be connected directly to the card I/O. This modification is backward compatible with previous designs, and no board modification is required.

8 Order codes

Table 41. Order codes

Partnumber	FLASH Kbytes	RAM Kbytes	EMI	USB	CAN	I/O Ports	Package	Temp. Range	
STR710FZ1T6	128+16	32	Yes	Yes	Yes	48	LQFP144 20 x 20	-40 to +85°C	
STR710FZ2T6	256+16	64							
STR710RZT6	0	64							
STR710FZ1H6	128+16	32	Yes	Yes	Yes	48	LFBGA144 10 x 10 1.7		
STR710FZ2H6	256+16	64							
STR710RZH6	0	64							
STR711FR0H6	64+16	16	No	Yes	No	30	LFBGA64 8 x 8 1.7		
STR711FR1H6	128+16	32							
STR711FR2H6	256+16	64							
STR711FR0T6	64+16	16					LQFP64 10x10		
STR711FR1T6	128+16	32							
STR711FR2T6	256+16	64							
STR712FR0H6	64+16	16		No	No	Yes	32		LFBGA64 8 x 8 1.7
STR712FR1H6	128+16	32							
STR712FR2H6	256+16	64							
STR712FR0T6	64+16	16					LQFP64 10 x 10		
STR712FR1T6	128+16	32							
STR712FR2T6	256+16	64							
STR715FR0H6	64+16	16		No	No	No	32	LFBGA64 8 x 8 1.7	
STR715FR0T1	64+16	16						LQFP64 10 x 10	
STR715FR0T6	64+16	16							

9 Revision history

Table 42. Document revision history

Date	Revision	Changes
17-Mar-2004	1	First Release
05-Apr-2004	2	Updated "Electrical parameters" on page 33
08-Apr-2004	2.1	Corrected STR712F Pinout. Pins 43/42 swapped.
15-Apr-2004	2.2	PDF hyperlinks corrected.
7-Jul-2004	3	Corrected description of STDBY, V18, VSS18 V18BKP VSSBKP pins Added IDDrn typical data Updated BSPI max. baudrate. Updated "EMI - External Memory Interface" on page 56
29-Oct-2004	4	Corrected Flash sector B1F0/F1 address in Figure 6: Memory map on page 30 Corrected Table 6 on page 24 LQFP64 TEST pin is 16 instead of 17. Added to TQFP64 column: pin 7 BOOTEN, pin 17 V _{33IO-PLL} Changed description of JTCK from 'External pull-down required' to 'External pull-up or pull down required'.
25-Jan-2005	5	Changed "Product Preview" to "Preliminary Data" on page 1 and 3 Renamed 'PU/PD' column to 'Reset state' in Table 6 on page 24 Added reference to STR7 Flash Programming Reference Manual
19-Apr-2005	6	Added STR715F devices and modified RAM size of STR71xF1 devices Added BGA package in Section 6 Updated ordering information in Section 8 . Added PLL duty cycle min and max. in PLL electrical characteristics on page 44
13-Oct-2005	7	Updated feature description on page 1 Update overview Section 1.1 Added OD/PP to P0.12 in Table 6 Changed name of WFI mode to WAIT mode Changed Memory Map Table 6 : Ext. Memory changed to 64 MB and flash register changed to 36 bytes. Added Power Consumption Table 14 Modified BGA144 F3, F5, F12 and G12 in Table 2 and Table 3 Update EMI Timing Table 25 and Figure 29

Table 42. Document revision history

Date	Revision	Changes
22-May-2006	8	Added Flashless device. Changed reset state of pins P1.10 and P1.13 from pu to pd, P0.15 from pu to floating and removed x in interrupt column for P1.15 and P1.12 in Table 3 and Table 6 Added notes under Table 3 on EMI pin reset state. Corrected inch value for d3 in Figure 39 Added footprint diagrams in Figure 39 and Figure 42 Updated Section 5: Electrical parameters
01-Aug-2006	9	Flash data retention changed to 20 years at 85° C. Changed note 8 on page 19 Changed note 1 on page 45
06-Nov-2006	10	Added STR715FR0T1 in Table 41: Order codes P0.12 corrected in Table 6 on page 24
20-Mar-2007	11	Added characteristics of BSPI - Buffered Serial Peripheral Interface on page 63 Updated Table 22: Low-power mode wake-up timing on page 45

Please Read Carefully:

Information in this document is provided solely in connection with ST products. STMicroelectronics NV and its subsidiaries ("ST") reserve the right to make changes, corrections, modifications or improvements, to this document, and the products and services described herein at any time, without notice.

All ST products are sold pursuant to ST's terms and conditions of sale.

Purchasers are solely responsible for the choice, selection and use of the ST products and services described herein, and ST assumes no liability whatsoever relating to the choice, selection or use of the ST products and services described herein.

No license, express or implied, by estoppel or otherwise, to any intellectual property rights is granted under this document. If any part of this document refers to any third party products or services it shall not be deemed a license grant by ST for the use of such third party products or services, or any intellectual property contained therein or considered as a warranty covering the use in any manner whatsoever of such third party products or services or any intellectual property contained therein.

UNLESS OTHERWISE SET FORTH IN ST'S TERMS AND CONDITIONS OF SALE ST DISCLAIMS ANY EXPRESS OR IMPLIED WARRANTY WITH RESPECT TO THE USE AND/OR SALE OF ST PRODUCTS INCLUDING WITHOUT LIMITATION IMPLIED WARRANTIES OF MERCHANTABILITY, FITNESS FOR A PARTICULAR PURPOSE (AND THEIR EQUIVALENTS UNDER THE LAWS OF ANY JURISDICTION), OR INFRINGEMENT OF ANY PATENT, COPYRIGHT OR OTHER INTELLECTUAL PROPERTY RIGHT.

UNLESS EXPRESSLY APPROVED IN WRITING BY AN AUTHORIZED ST REPRESENTATIVE, ST PRODUCTS ARE NOT RECOMMENDED, AUTHORIZED OR WARRANTED FOR USE IN MILITARY, AIR CRAFT, SPACE, LIFE SAVING, OR LIFE SUSTAINING APPLICATIONS, NOR IN PRODUCTS OR SYSTEMS WHERE FAILURE OR MALFUNCTION MAY RESULT IN PERSONAL INJURY, DEATH, OR SEVERE PROPERTY OR ENVIRONMENTAL DAMAGE. ST PRODUCTS WHICH ARE NOT SPECIFIED AS "AUTOMOTIVE GRADE" MAY ONLY BE USED IN AUTOMOTIVE APPLICATIONS AT USER'S OWN RISK.

Resale of ST products with provisions different from the statements and/or technical features set forth in this document shall immediately void any warranty granted by ST for the ST product or service described herein and shall not create or extend in any manner whatsoever, any liability of ST.

ST and the ST logo are trademarks or registered trademarks of ST in various countries.

Information in this document supersedes and replaces all information previously supplied.

The ST logo is a registered trademark of STMicroelectronics. All other names are the property of their respective owners.

© 2007 STMicroelectronics - All rights reserved

STMicroelectronics group of companies

Australia - Belgium - Brazil - Canada - China - Czech Republic - Finland - France - Germany - Hong Kong - India - Israel - Italy - Japan - Malaysia - Malta - Morocco - Singapore - Spain - Sweden - Switzerland - United Kingdom - United States of America

www.st.com