

VOLTAGE RANGE: 60V

CURRENT: 20A

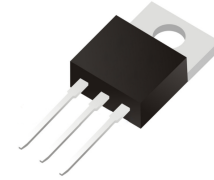

Features

- Ultra low vf
- High efficiency operation
- Low power loss
- Low stored charge majority carrier conduction
- High forward surge capability
- Lead free in compliance with EU RoHS 2011/65/EU directive

Mechanical Data

- Circuit figure: Common cathode
- Leads: Solderable per mil-std-202, Method 208
- Polarity: as marked
- Mounting torque: 5 in-lbs maximum
- Terminals: Puretin plated
- Weight: TO-220AB 1.85 grams

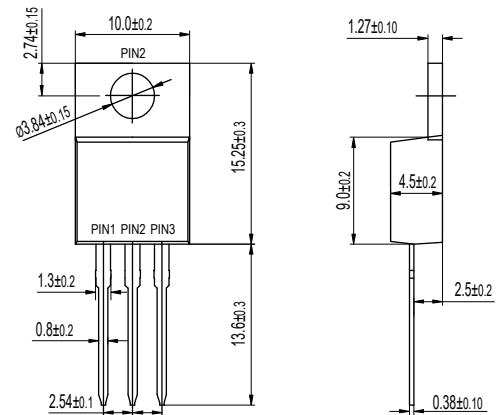

TO-220AB

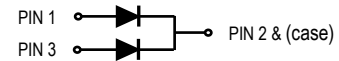

Maximum Ratings $T_A = 25^\circ\text{C}$ unless otherwise specified

RATINGS	SYMBOL	STPS20L60CT	UNIT
Maximum repetitive reverse voltage	VRRM	60	V
Maximum RMS voltage	VRMS	42	V
Maximum DC blocking voltage	VDC	60	V
Maximum average forward current per device per diode	I _{AV}	20 10	A
Peak forward surge current, 8.3ms single half sine-wave superimposed on rated load	I _{FSM}	200	A
Typical thermal resistance per diode (Note 1)	R _{θ-JC}	2.0	°C/W
Operating junction temperature range	T _J	-55 to +150	°C
Storage temperature range	T _{STG}	-55 to +150	°C

Notes: 1. Thermal resistance from junction to case.

Electrical Characteristics $T_A = 25^\circ\text{C}$ unless otherwise specified

PARAMETER	SYMBOL	TEST CONDITIONS	MIN.	TYP.	MAX.	UNIT
Breakdown voltage per diode	V _{BR}	I _R =0.5mA	60	-	-	V
Instantaneous forward voltage per diode	V _F	I _F =10A T _J =25°C	-	0.54	0.60	V
		I _F =10A T _J =125°C	-	-	0.54	V
Reverse current per diode	I _R	T _J =25°C	-	-	150	μA
		T _J =125°C	-	-	80	mA

FIG. 1 - TYPICAL FORWARD CURRENT DERATING CURVE

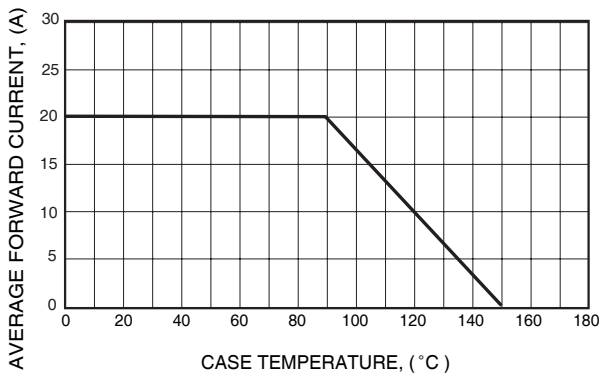

FIG. 2 - MAXIMUM NON-REPETITIVE FORWARD SURGE CURRENT

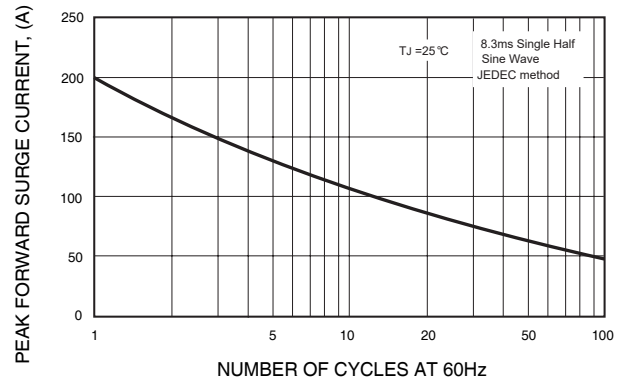

FIG. 3 - TYPICAL REVERSE CHARACTERISTICS

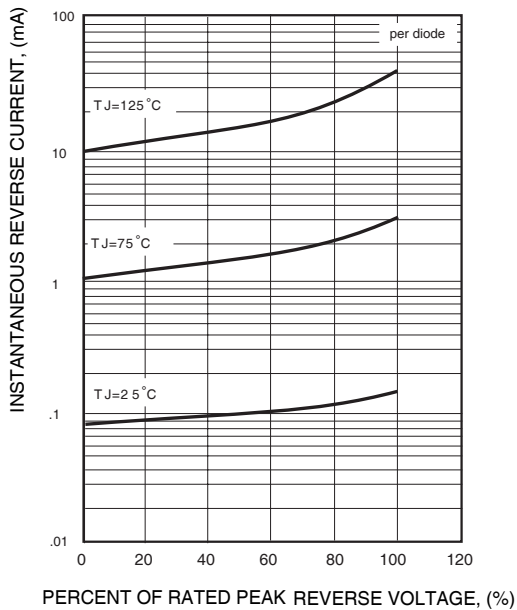

FIG. 4 - TYPICAL INSTANTANEOUS FORWARD CHARACTERISTICS

