

Value line, 16 MHz STM8S 8-bit MCU, 32 Kbytes Flash, data EEPROM, 10-bit ADC, timers, UART, SPI, I²C

Datasheet - production data

Features

Core

- Max f_{CPU} : 16 MHz
- Advanced STM8 core with Harvard architecture and 3-stage pipeline
- Extended instruction set

Memories

- Medium-density Flash/EEPROM
 - Program memory: 32 Kbytes of Flash memory; data retention 20 years at 55 °C after 100 cycles
 - Data memory: 128 bytes true data EEPROM; endurance up to 100 k write/erase cycles
- RAM: 2 Kbytes

Clock, reset and supply management

- 2.95 V to 5.5 V operating voltage
- Flexible clock control, 4 master clock sources
 - Low-power crystal resonator oscillator
 - External clock input
 - Internal, user-trimmable 16 MHz RC
 - Internal low-power 128 kHz RC
- Clock security system with clock monitor
- Power management
 - Low-power modes (wait, active-halt, halt)
 - Switch-off peripheral clocks individually
 - Permanently active, low-consumption power-on and power-down reset

Interrupt management

- Nested interrupt controller with 32 interrupts
- Up to 37 external interrupts on 6 vectors

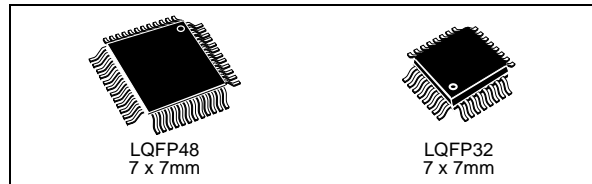

Timers

- 2x 16-bit general purpose timers, with 2+3 CAPCOM channels (IC, OC or PWM)
- Advanced control timer: 16-bit, 4 CAPCOM channels, 3 complementary outputs, dead-time insertion and flexible synchronization
- 8-bit basic timer with 8-bit prescaler
- Auto wakeup timer
- Window and independent watchdog timers

Communications interfaces

- UART with clock output for synchronous operation, SmartCard, IrDA, LIN
- SPI interface up to 8 Mbit/s
- I²C interface up to 400 Kbit/s

Analog to digital converter (ADC)

- 10-bit ADC, ± 1 LSB ADC with up to 10 multiplexed channels, scan mode and analog watchdog

I/Os

- Up to 38 I/Os on a 48-pin package including 16 high-sink outputs
- Highly robust I/O design, immune against current injection

Development support

- Embedded single-wire interface module (SWIM) for fast on-chip programming and non-intrusive debugging

Contents

1	Introduction	9
2	Description	10
3	Block diagram	11
4	Product overview	12
4.1	Central processing unit STM8	12
4.2	Single wire interface module (SWIM) and debug module (DM)	13
4.3	Interrupt controller	13
4.4	Flash program and data EEPROM memory	13
4.5	Clock controller	15
4.6	Power management	16
4.7	Watchdog timers	16
4.8	Auto wakeup counter	17
4.9	Beeper	17
4.10	TIM1 - 16-bit advanced control timer	17
4.11	TIM2, TIM3 - 16-bit general purpose timers	17
4.12	TIM4 - 8-bit basic timer	18
4.13	Analog-to-digital converter (ADC1)	18
4.14	Communication interfaces	18
4.14.1	UART2	19
4.14.2	SPI	20
4.14.3	I ² C	20
5	Pinouts and pin descriptions	21
5.1	Alternate function remapping	25
6	Memory and register map	26
6.1	Memory map	26
6.2	Register map	27
7	Interrupt vector mapping	37

8	Option bytes	38
9	Electrical characteristics	42
9.1	Parameter conditions	42
9.1.1	Minimum and maximum values	42
9.1.2	Typical values	42
9.1.3	Typical curves	42
9.1.4	Typical current consumption	42
9.1.5	Pin loading conditions	43
9.1.6	Loading capacitor	43
9.1.7	Pin input voltage	43
9.2	Absolute maximum ratings	44
9.3	Operating conditions	46
9.3.1	VCAP external capacitor	48
9.3.2	Supply current characteristics	48
9.3.3	External clock sources and timing characteristics	58
9.3.4	Internal clock sources and timing characteristics	60
9.3.5	Memory characteristics	62
9.3.6	I/O port pin characteristics	63
9.3.7	Reset pin characteristics	72
9.3.8	SPI serial peripheral interface	74
9.3.9	I ² C interface characteristics	77
9.3.10	10-bit ADC characteristics	79
9.3.11	EMC characteristics	82
10	Package information	85
10.1	LQFP48 package information	85
10.2	LQFP32 package information	88
10.3	Thermal characteristics	91
10.3.1	Reference document	91
10.3.2	Selecting the product temperature range	92
11	Part numbering	93
12	STM8 development tools	94
12.1	Emulation and in-circuit debugging tools	94

12.2	Software tools	95
12.2.1	STM8 toolset	95
12.2.2	C and assembly toolchains	95
12.3	Programming tools	95
13	Revision history	96

List of tables

Table 1.	STM8S005C6/K6 value line features	10
Table 2.	Peripheral clock gating bit assignments in CLK_PCKENR1/2 registers	15
Table 3.	TIM timer features	18
Table 4.	Legend/abbreviations for STM8S005C6/K6 pin descriptions table	22
Table 5.	STM8S005C6 and STM8S005K6 pin descriptions	23
Table 6.	Flash, Data EEPROM and RAM boundary addresses	27
Table 7.	I/O port hardware register map	27
Table 8.	General hardware register map	29
Table 9.	CPU/SWIM/debug module/interrupt controller registers	35
Table 10.	Interrupt mapping	37
Table 11.	Option bytes	38
Table 12.	Option byte description	39
Table 13.	Description of alternate function remapping bits [7:0] of OPT2	41
Table 14.	Voltage characteristics	44
Table 15.	Current characteristics	45
Table 16.	Thermal characteristics	45
Table 17.	General operating conditions	46
Table 18.	Operating conditions at power-up/power-down	47
Table 19.	Total current consumption with code execution in run mode at $V_{DD} = 5\text{ V}$	49
Table 20.	Total current consumption with code execution in run mode at $V_{DD} = 3.3\text{ V}$	50
Table 21.	Total current consumption in wait mode at $V_{DD} = 5\text{ V}$	51
Table 22.	Total current consumption in wait mode at $V_{DD} = 3.3\text{ V}$	51
Table 23.	Total current consumption in active halt mode at $V_{DD} = 5\text{ V}$, $T_A -40\text{ to }85^\circ\text{ C}$	52
Table 24.	Total current consumption in active halt mode at $V_{DD} = 3.3\text{ V}$	52
Table 25.	Total current consumption in halt mode at $V_{DD} = 5\text{ V}$, $T_A -40\text{ to }85^\circ\text{ C}$	53
Table 26.	Total current consumption in halt mode at $V_{DD} = 3.3\text{ V}$	53
Table 27.	Wakeup times	53
Table 28.	Total current consumption and timing in forced reset state	54
Table 29.	Peripheral current consumption	54
Table 30.	HSE user external clock characteristics	58
Table 31.	HSE oscillator characteristics	59
Table 32.	HSI oscillator characteristics	60
Table 33.	LSI oscillator characteristics	61
Table 34.	RAM and hardware registers	62
Table 35.	Flash program memory/data EEPROM memory	62
Table 36.	I/O static characteristics	63
Table 37.	Output driving current (standard ports)	65
Table 38.	Output driving current (true open drain ports)	65
Table 39.	Output driving current (high sink ports)	66
Table 40.	NRST pin characteristics	72
Table 41.	SPI characteristics	74
Table 42.	I ² C characteristics	77
Table 43.	ADC characteristics	79
Table 44.	ADC accuracy with $R_{AIN} < 10\text{ k}\Omega$, $V_{DDA} = 5\text{ V}$	80
Table 45.	ADC accuracy with $R_{AIN} < 10\text{ k}\Omega$, R_{AIN} , $V_{DDA} = 3.3\text{ V}$	80
Table 46.	EMS data	82
Table 47.	EMI data	83
Table 48.	ESD absolute maximum ratings	83

Table 49.	Electrical sensitivities	84
Table 50.	LQFP48 - 48-pin, 7 x 7 mm low-profile quad flat package mechanical data.	86
Table 51.	LQFP32 - 32-pin, 7 x 7 mm low-profile quad flat package mechanical data.	89
Table 52.	Thermal characteristics.....	91
Table 53.	Document revision history	96

List of figures

Figure 1.	STM8S005C6/K6 value line block diagram	11
Figure 2.	Flash memory organisation	14
Figure 3.	LQFP 48-pin pinout	21
Figure 4.	LQFP 32-pin pinout	22
Figure 5.	Memory map	26
Figure 6.	Supply current measurement conditions	42
Figure 7.	Pin loading conditions	43
Figure 8.	Pin input voltage	43
Figure 9.	f_{CPUmax} versus V_{DD}	47
Figure 10.	External capacitor C_{EXT}	48
Figure 11.	Typ. $I_{DD(RUN)}$ vs V_{DD} , HSE user external clock, $f_{CPU} = 16$ MHz	55
Figure 12.	Typ. $I_{DD(RUN)}$ vs V_{DD} , HSE user external clock, $V_{DD} = 5$ V	55
Figure 13.	Typ. $I_{DD(WFI)}$ vs V_{DD} , HSE user external clock, $f_{CPU} = 16$ MHz	56
Figure 14.	Typ. $I_{DD(WFI)}$ vs V_{DD} , HSE user external clock, $V_{DD} = 5$ V	56
Figure 15.	Typ. $I_{DD(RUN)}$ vs V_{DD} , HSI RC osc, $f_{CPU} = 16$ MHz	57
Figure 16.	Typ. $I_{DD(WFI)}$ vs V_{DD} , HSI RC osc, $f_{CPU} = 16$ MHz	57
Figure 17.	HSE external clock source	58
Figure 18.	HSE oscillator circuit diagram	59
Figure 19.	Typical HSI frequency variation vs V_{DD} at 3 temperatures	60
Figure 20.	Typical LSI frequency variation vs V_{DD} @ 25 °C	61
Figure 21.	Typical V_{IL} and V_{IH} vs V_{DD} @ 3 temperatures	64
Figure 22.	Typical pull-up resistance vs V_{DD} @ 3 temperatures	64
Figure 23.	Typical pull-up current vs V_{DD} @ 3 temperatures	65
Figure 24.	Typ. V_{OL} @ $V_{DD} = 5$ V (standard ports)	66
Figure 25.	Typ. V_{OL} @ $V_{DD} = 3.3$ V (standard ports)	67
Figure 26.	Typ. V_{OL} @ $V_{DD} = 5$ V (true open drain ports)	67
Figure 27.	Typ. V_{OL} @ $V_{DD} = 3.3$ V (true open drain ports)	68
Figure 28.	Typ. V_{OL} @ $V_{DD} = 5$ V (high sink ports)	68
Figure 29.	Typ. V_{OL} @ $V_{DD} = 3.3$ V (high sink ports)	69
Figure 30.	Typ. $V_{DD} - V_{OH}$ @ $V_{DD} = 5$ V (standard ports)	69
Figure 31.	Typ. $V_{DD} - V_{OH}$ @ $V_{DD} = 3.3$ V (standard ports)	70
Figure 32.	Typ. $V_{DD} - V_{OH}$ @ $V_{DD} = 5$ V (high sink ports)	70
Figure 33.	Typ. $V_{DD} - V_{OH}$ @ $V_{DD} = 3.3$ V (high sink ports)	71
Figure 34.	Typical NRST V_{IL} and V_{IH} vs V_{DD} @ 3 temperatures	72
Figure 35.	Typical NRST pull-up resistance vs V_{DD} @ 3 temperatures	73
Figure 36.	Typical NRST pull-up current vs V_{DD} @ 3 temperatures	73
Figure 37.	Recommended reset pin protection	74
Figure 38.	SPI timing diagram - slave mode and $CPHA = 0$	75
Figure 39.	SPI timing diagram - slave mode and $CPHA = 1^{(1)}$	75
Figure 40.	SPI timing diagram - master mode ⁽¹⁾	76
Figure 41.	Typical application with I ² C bus and timing diagram	78
Figure 42.	ADC accuracy characteristics	81
Figure 43.	Typical application with ADC	81
Figure 44.	LQFP48 - 48-pin, 7 x 7 mm low-profile quad flat package outline	85
Figure 45.	LQFP48 - 48-pin, 7 x 7 mm low-profile quad flat recommended footprint	87
Figure 46.	LQFP48 marking example (package top view)	87
Figure 47.	LQFP32 - 32-pin, 7 x 7 mm low-profile quad flat package outline	88
Figure 48.	LQFP32 - 32-pin, 7 x 7 mm low-profile quad flat recommended footprint	89

Figure 49. LQFP32 marking example (package top view) 90
Figure 50. STM8S005C6/K6 value line ordering information scheme⁽¹⁾ 93

1 Introduction

This datasheet contains the description of the STM8S005C6/K6 value line features, pinout, electrical characteristics, mechanical data and ordering information.

- For complete information on the STM8S microcontroller memory, registers and peripherals, please refer to the STM8S and STM8A microcontroller families reference manual (RM0016).
- For information on programming, erasing and protection of the internal Flash memory please refer to the PM0051 (How to program STM8S and STM8A Flash program memory and data EEPROM).
- For information on the debug and SWIM (single wire interface module) refer to the STM8 SWIM communication protocol and debug module user manual (UM0470).
- For information on the STM8 core, please refer to the STM8 CPU programming manual (PM0044).

2 Description

The STM8S005C6/K6 value line 8-bit microcontrollers offer 32 Kbytes Flash program memory, plus 128 bytes of data EEPROM. They are referred to as medium-density devices in the STM8S microcontroller family reference manual (RM0016).

All devices of STM8S005C6/K6 value line provide the following benefits: performance, robustness, reduced system cost and short development cycles.

Device performance and robustness are ensured by true data EEPROM supporting up to 100000 write/erase cycles, advanced core and peripherals made in a state-of-the-art technology at 16 MHz clock frequency, robust I/Os, independent watchdogs with separate clock source, and a clock security system.

The system cost is reduced thanks to a high system integration level with internal clock oscillators, watchdog, and brown-out reset.

The common family product architecture with compatible pinout, memory map and modular peripherals allow application scalability and reduced development cycles.

All products operate from a 2.95 V to 5.5 V supply voltage.

Full documentation is offered as well as a wide choice of development tools.

Table 1. STM8S005C6/K6 value line features

Features	STM8S005C6	STM8S005K6
Pin count	48	32
Max. number of GPIOs (I/O)	38	25
External interrupt pins	35	23
Timer CAPCOM channels	9	8
Timer complementary outputs	3	3
A/D converter channels	10	7
High-sink I/Os	16	12
High-density Flash program memory (bytes)	32 K	32 K
Data EEPROM (bytes)	128	128
RAM (bytes)	2 K	2 K
Peripheral set	Advanced control timer (TIM1), general purpose timers (TIM2 and TIM3), basic timer (TIM4), SPI, I2C, UART, Window WDG, independent WDG, ADC	

3 Block diagram

Figure 1. STM8S005C6/K6 value line block diagram

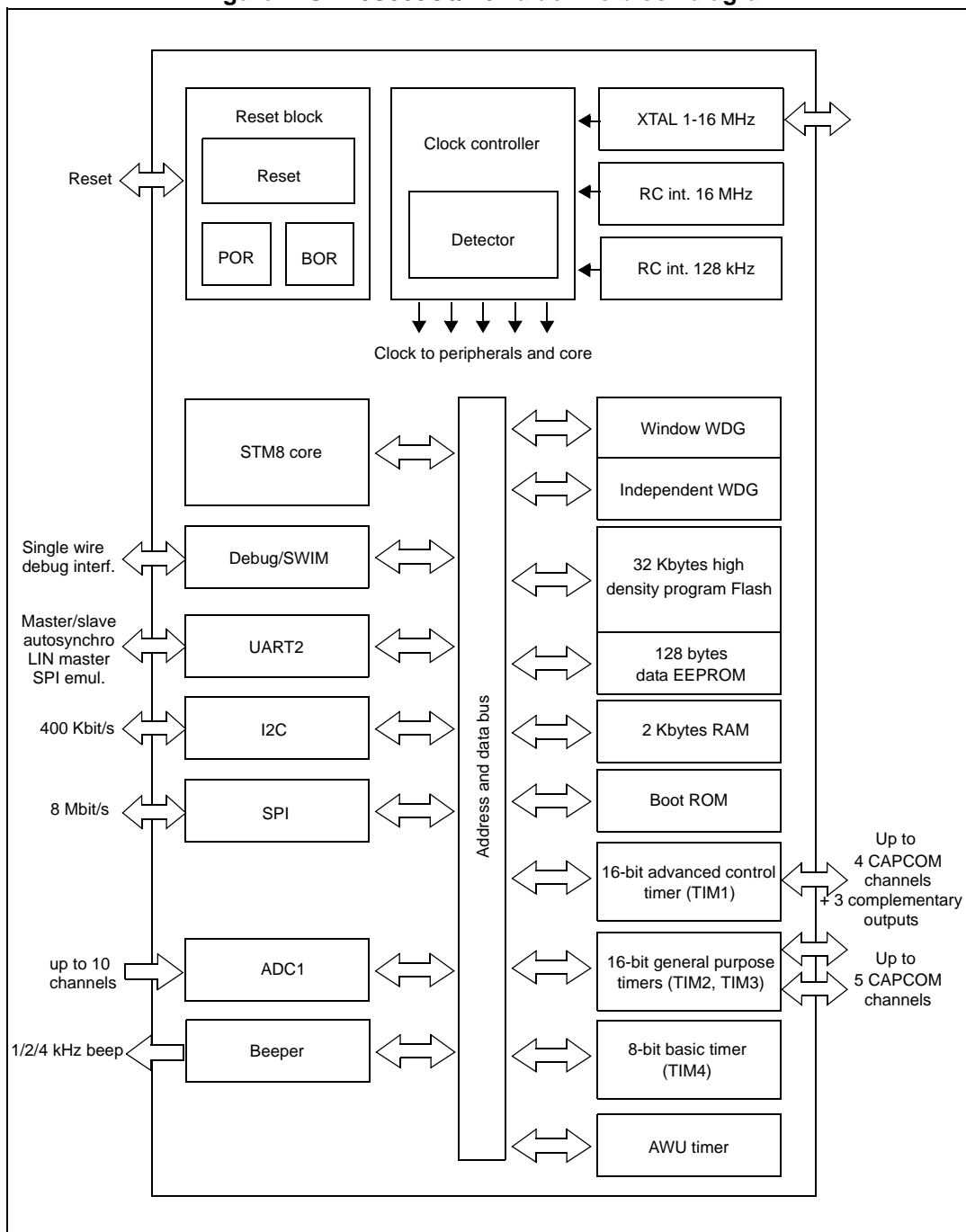

4 Product overview

The following section intends to give an overview of the basic features of the STM8S005C6/K6 value line functional modules and peripherals.

For more detailed information please refer to the corresponding family reference manual (RM0016).

4.1 Central processing unit STM8

The 8-bit STM8 core is designed for code efficiency and performance.

It contains six internal registers which are directly addressable in each execution context, 20 addressing modes including indexed indirect and relative addressing and 80 instructions.

Architecture and registers

- Harvard architecture
- 3-stage pipeline
- 32-bit wide program memory bus - single cycle fetching for most instructions
- X and Y 16-bit index registers - enabling indexed addressing modes with or without offset and read-modify-write type data manipulations
- 8-bit accumulator
- 24-bit program counter - 16-Mbyte linear memory space
- 16-bit stack pointer - access to a 64 K-level stack
- 8-bit condition code register - 7 condition flags for the result of the last instruction

Addressing

- 20 addressing modes
- Indexed indirect addressing mode for look-up tables located anywhere in the address space
- Stack pointer relative addressing mode for local variables and parameter passing

Instruction set

- 80 instructions with 2-byte average instruction size
- Standard data movement and logic/arithmetic functions
- 8-bit by 8-bit multiplication
- 16-bit by 8-bit and 16-bit by 16-bit division
- Bit manipulation
- Data transfer between stack and accumulator (push/pop) with direct stack access
- Data transfer using the X and Y registers or direct memory-to-memory transfers

4.2 Single wire interface module (SWIM) and debug module (DM)

The single wire interface module and debug module permits non-intrusive, real-time in-circuit debugging and fast memory programming.

SWIM

Single wire interface module for direct access to the debug module and memory programming. The interface can be activated in all device operation modes. The maximum data transmission speed is 145 bytes/ms.

Debug module

The non-intrusive debugging module features a performance close to a full-featured emulator. Beside memory and peripherals, also CPU operation can be monitored in real-time by means of shadow registers.

- R/W to RAM and peripheral registers in real-time
- R/W access to all resources by stalling the CPU
- Breakpoints on all program-memory instructions (software breakpoints)
- Two advanced breakpoints, 23 predefined configurations

4.3 Interrupt controller

- Nested interrupts with three software priority levels
- 32 interrupt vectors with hardware priority
- Up to 33 external interrupts on six vectors including TLI
- Trap and reset interrupts

4.4 Flash program and data EEPROM memory

- 32 Kbytes of high density Flash program single voltage Flash memory
- 128 bytes true data EEPROM
- Read while write: Writing in data memory possible while executing code in program memory.
- User option byte area

Write protection (WP)

Write protection of Flash program memory and data EEPROM is provided to avoid unintentional overwriting of memory that could result from a user software malfunction.

There are two levels of write protection. The first level is known as MASS (memory access security system). MASS is always enabled and protects the main Flash program memory, data EEPROM and option bytes.

To perform in-application programming (IAP), this write protection can be removed by writing a MASS key sequence in a control register. This allows the application to write to data EEPROM, modify the contents of main program memory or the device option bytes.

A second level of write protection, can be enabled to further protect a specific area of memory known as UBC (user boot code). Refer to [Figure 2](#).

The size of the UBC is programmable through the UBC option byte (Table 12), in increments of 1 page (512 bytes) by programming the UBC option byte in ICP mode.

This divides the program memory into two areas:

- Main program memory: 32 Kbytes minus UBC
- User-specific boot code (UBC): Configurable up to 32 Kbytes

The UBC area remains write-protected during in-application programming. This means that the MASS keys do not unlock the UBC area. It protects the memory used to store the boot program, specific code libraries, reset and interrupt vectors, the reset routine and usually the IAP and communication routines.

Figure 2. Flash memory organisation

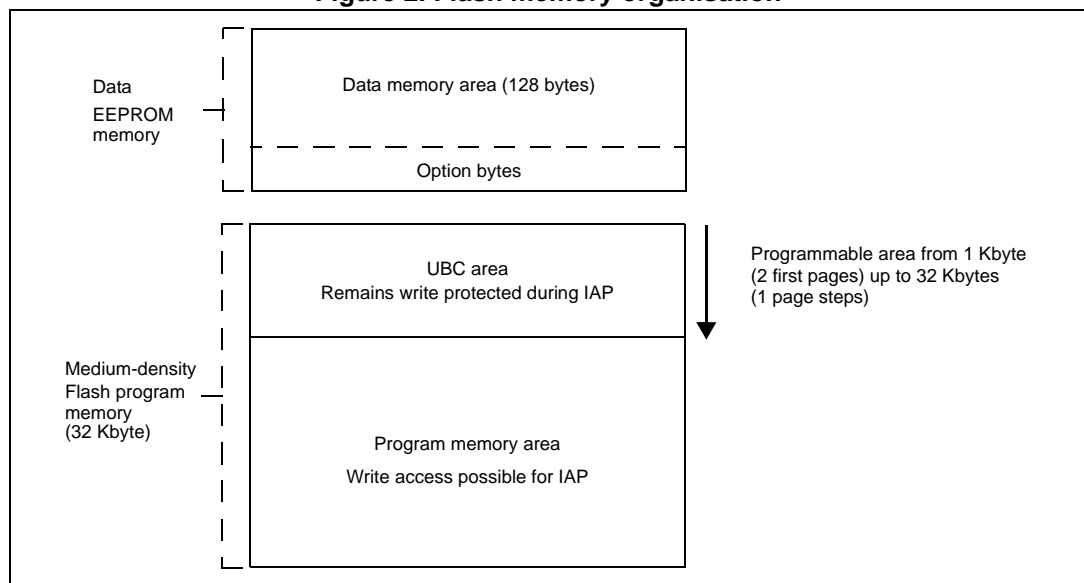

Read-out protection (ROP)

The read-out protection blocks reading and writing the Flash program memory and data EEPROM memory in ICP mode (and debug mode). Once the read-out protection is activated, any attempt to toggle its status triggers a global erase of the program and data memory. Even if no protection can be considered as totally unbreakable, the feature provides a very high level of protection for a general purpose microcontroller.

4.5 Clock controller

The clock controller distributes the system clock (f_{MASTER}) coming from different oscillators to the core and the peripherals. It also manages clock gating for low power modes and ensures clock robustness.

Features

- **Clock prescaler:** To get the best compromise between speed and current consumption the clock frequency to the CPU and peripherals can be adjusted by a programmable prescaler.
- **Safe clock switching:** Clock sources can be changed safely on the fly in run mode through a configuration register. The clock signal is not switched until the new clock source is ready. The design guarantees glitch-free switching.
- **Clock management:** To reduce power consumption, the clock controller can stop the clock to the core, individual peripherals or memory.
- **Master clock sources:** Four different clock sources can be used to drive the master clock:
 - 1-16 MHz high-speed external crystal (HSE)
 - Up to 16 MHz high-speed user-external clock (HSE user-ext)
 - 16 MHz high-speed internal RC oscillator (HSI)
 - 128 kHz low-speed internal RC (LSI)
- **Startup clock:** After reset, the microcontroller restarts by default with an internal 2 MHz clock (HSI/8). The prescaler ratio and clock source can be changed by the application program as soon as the code execution starts.
- **Clock security system (CSS):** This feature can be enabled by software. If an HSE clock failure occurs, the internal RC (16 MHz/8) is automatically selected by the CSS and an interrupt can optionally be generated.
- **Configurable main clock output (CCO):** This outputs an external clock for use by the application.

Table 2. Peripheral clock gating bit assignments in CLK_PCKENR1/2 registers

Bit	Peripheral clock	Bit	Peripheral clock	Bit	Peripheral clock	Bit	Peripheral clock
PCKEN17	TIM1	PCKEN13	UART2	PCKEN27	Reserved	PCKEN23	ADC
PCKEN16	TIM3	PCKEN12	Reserved	PCKEN26	Reserved	PCKEN22	AWU
PCKEN15	TIM2	PCKEN11	SPI	PCKEN25	Reserved	PCKEN21	Reserved
PCKEN14	TIM4	PCKEN10	I ² C	PCKEN24	Reserved	PCKEN20	Reserved

4.6 Power management

For efficient power management, the application can be put in one of four different low-power modes. You can configure each mode to obtain the best compromise between lowest power consumption, fastest start-up time and available wakeup sources.

- **Wait mode:** In this mode, the CPU is stopped, but peripherals are kept running. The wakeup is performed by an internal or external interrupt or reset.
- **Active halt mode with regulator on:** In this mode, the CPU and peripheral clocks are stopped. An internal wakeup is generated at programmable intervals by the auto wake up unit (AWU). The main voltage regulator is kept powered on, so current consumption is higher than in active halt mode with regulator off, but the wakeup time is faster. Wakeup is triggered by the internal AWU interrupt, external interrupt or reset.
- **Active halt mode with regulator off:** This mode is the same as active halt with regulator on, except that the main voltage regulator is powered off, so the wake up time is slower.
- **Halt mode:** In this mode the microcontroller uses the least power. The CPU and peripheral clocks are stopped, the main voltage regulator is powered off. Wakeup is triggered by external event or reset.

4.7 Watchdog timers

The watchdog system is based on two independent timers providing maximum security to the applications.

Activation of the watchdog timers is controlled by option bytes or by software. Once activated, the watchdogs cannot be disabled by the user program without performing a reset.

Window watchdog timer

The window watchdog is used to detect the occurrence of a software fault, usually generated by external interferences or by unexpected logical conditions, which cause the application program to abandon its normal sequence.

The window function can be used to trim the watchdog behavior to match the application perfectly.

The application software must refresh the counter before time-out and during a limited time window.

A reset is generated in two situations:

1. Timeout: at 16 MHz CPU clock the time-out period can be adjusted between 75 μ s up to 64 ms.
2. Refresh out of window: The downcounter is refreshed before its value is lower than the one stored in the window register.

Independent watchdog timer

The independent watchdog peripheral can be used to resolve processor malfunctions due to hardware or software failures.

It is clocked by the 128 kHz LSI internal RC clock source, and thus stays active even in case of a CPU clock failure

The IWDG time base spans from 60 μ s to 1 s.

4.8 Auto wakeup counter

- Used for auto wakeup from active halt mode
- Clock source: Internal 128 kHz internal low frequency RC oscillator or external clock
- LSI clock can be internally connected to TIM3 input capture channel 1 for calibration

4.9 Beeper

The beeper function outputs a signal on the BEEP pin for sound generation. The signal is in the range of 1, 2 or 4 kHz.

The beeper output port is only available through the alternate function remap option bit AFR7.

4.10 TIM1 - 16-bit advanced control timer

This is a high-end timer designed for a wide range of control applications. With its complementary outputs, dead-time control and center-aligned PWM capability, the field of applications is extended to motor control, lighting and half-bridge driver

- 16-bit up, down and up/down autoreload counter with 16-bit prescaler
- Four independent capture/compare channels (CAPCOM) configurable as input capture, output compare, PWM generation (edge and center aligned mode) and single pulse mode output
- Synchronization module to control the timer with external signals
- Break input to force the timer outputs into a defined state
- Three complementary outputs with adjustable dead time
- Encoder mode
- Interrupt sources: 3 x input capture/output compare, 1 x overflow/update, 1 x break

4.11 TIM2, TIM3 - 16-bit general purpose timers

- 16-bit autoreload (AR) up-counter
- 15-bit prescaler adjustable to fixed power of 2 ratios 1...32768
- Timers with 3 or 2 individually configurable capture/compare channels
- PWM mode
- Interrupt sources: 2 or 3 x input capture/output compare, 1 x overflow/update

4.12 TIM4 - 8-bit basic timer

- 8-bit autoreload, adjustable prescaler ratio to any power of 2 from 1 to 128
- Clock source: CPU clock
- Interrupt source: 1 x overflow/update

Table 3. TIM timer features

Timer	Counter size (bits)	Prescaler	Counting mode	CAPCOM channels	Complem. outputs	Ext. trigger	Timer synchronization/chaining
TIM1	16	Any integer from 1 to 65536	Up/down	4	3	Yes	No
TIM2	16	Any power of 2 from 1 to 32768	Up	3	0	No	
TIM3	16	Any power of 2 from 1 to 32768	Up	2	0	No	
TIM4	8	Any power of 2 from 1 to 128	Up	0	0	No	

4.13 Analog-to-digital converter (ADC1)

STM8S005C6/K6 value line products contain a 10-bit successive approximation A/D converter (ADC1) with up to 10 multiplexed input channels and the following main features:

- Input voltage range: 0 to V_{DDA}
- Conversion time: 14 clock cycles
- Single and continuous, buffered continuous conversion modes
- Buffer size (10 x 10 bits)
- Scan mode for single and continuous conversion of a sequence of channels
- Analog watchdog capability with programmable upper and lower thresholds
- Analog watchdog interrupt
- External trigger input
- Trigger from TIM1 TRGO
- End of conversion (EOC) interrupt

Note: Additional AIN12 analog input is not selectable in ADC scan mode or with analog watchdog. Values converted from AIN12 are stored only into the ADC_DRH/ADC_DRL registers.

4.14 Communication interfaces

The following communication interfaces are implemented:

- UART2: full feature UART, synchronous mode, SPI master mode, SmartCard mode, IrDA mode, IIN2.1 master/slave capability
- SPI: full and half-duplex, 8 Mbit/s
- I²C: up to 400 Kbit/s

4.14.1 UART2

Main features

- 1 Mbit/s full duplex SCI
- SPI emulation
- High precision baud rate generator
- Smartcard emulation
- IrDA SIR encoder decoder
- LIN master mode
- Single wire half duplex mode

Asynchronous communication (UART mode)

- Full duplex communication - NRZ standard format (mark/space)
- Programmable transmit and receive baud rates up to 1 Mbit/s ($f_{CPU}/16$) and capable of following any standard baud rate regardless of the input frequency
- Separate enable bits for transmitter and receiver
- Two receiver wakeup modes:
 - Address bit (MSB)
 - Idle line (interrupt)
- Transmission error detection with interrupt generation
- Parity control

Synchronous communication

- Full duplex synchronous transfers
- SPI master operation
- 8-bit data communication
- Maximum speed: 1 Mbit/s at 16 MHz ($f_{CPU}/16$)

LIN master mode

- Emission: generates 13-bit synch. break frame
- Reception: detects 11-bit break frame

LIN slave mode

- Autonomous header handling - one-single interrupt per valid message header
- Automatic baud rate synchronization - maximum tolerated initial clock deviation $\pm 15\%$
- Synch. delimiter checking
- 11-bit LIN synch. break detection - break detection always active
- Parity check on the LIN identifier field
- LIN error management
- Hot plugging support

4.14.2 SPI

- Maximum speed: 8 Mbit/s ($f_{\text{MASTER}}/2$) both for master and slave
- Full duplex synchronous transfers
- Simplex synchronous transfers on two lines with a possible bidirectional data line
- Master or slave operation - selectable by hardware or software
- CRC calculation
- 1 byte Tx and Rx buffer
- Slave/master selection input pin

4.14.3 I²C

- I²C master features
 - Clock generation
 - Start and stop generation
- I²C slave features
 - Programmable I²C address detection
 - Stop bit detection
- Generation and detection of 7-bit/10-bit addressing and general call
- Supports different communication speeds
 - Standard speed (up to 100 kHz)
 - Fast speed (up to 400 kHz)

5 Pinouts and pin descriptions

Figure 3. LQFP 48-pin pinout

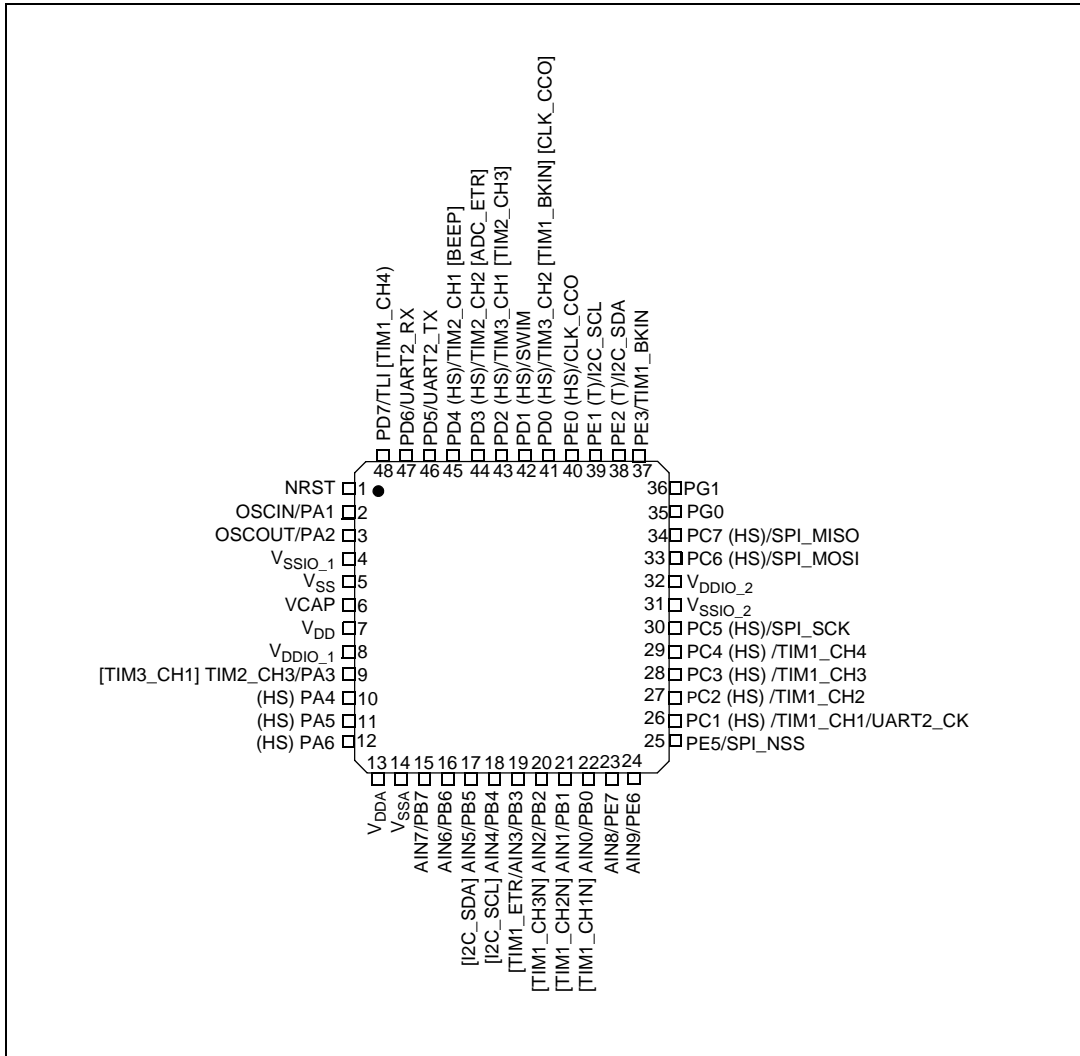

1. (HS) high sink capability.
2. (T) True open drain (P-buffer and protection diode to V_{DD} not implemented).
3. [] alternate function remapping option (If the same alternate function is shown twice, it indicates an exclusive choice not a duplication of the function).

Figure 4. LQFP 32-pin pinout

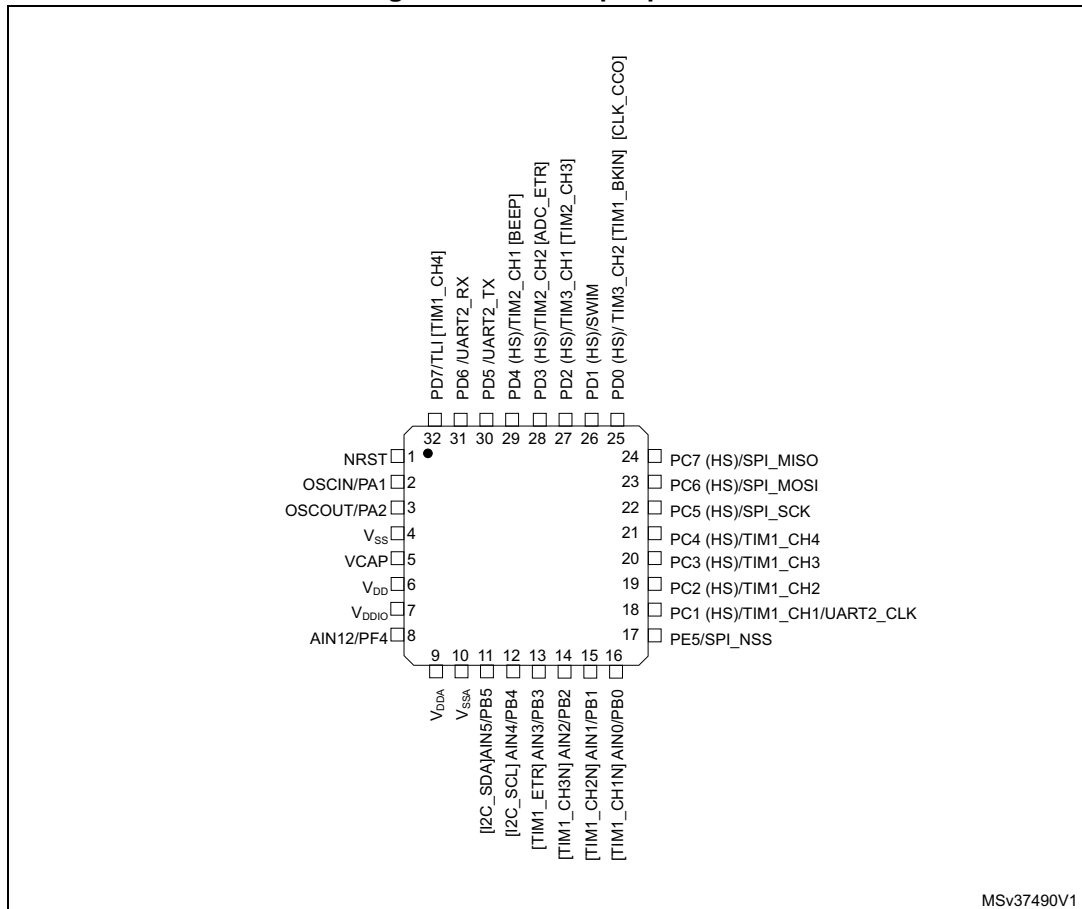

MSv37490V1

Table 4. Legend/abbreviations for STM8S005C6/K6 pin descriptions table

Type	I = input, O = output, S = power supply	
Level	Input	CM = CMOS
	Output	HS = high sink
Output speed	O1 = slow (up to 2 MHz) O2 = fast (up to 10 MHz) O3 = fast/slow programmability with slow as default state after reset O4 = fast/slow programmability with fast as default state after reset	
Port and control configuration	Input	float = floating, wpu = weak pull-up
	Output	T = true open drain, OD = open drain, PP = push pull
Reset state	Bold x (pin state after internal reset release) Unless otherwise specified, the pin state is the same during the reset phase and after the internal reset release.	

Table 5. STM8S005C6 and STM8S005K6 pin descriptions

Pin number		Pin name	Type	Input			Output				Main function (after reset)	Default alternate function	Alternate function after remap [option bit]
LQFP48	LQFP32			floating	wpu	Ext. interrupt	High sink	Speed	OD	PP			
1	1	NRST	I/O		X						Reset		
2	2	PA1/OSCIN	I/O	X	X			O1	X	X	Port A1	Resonator/crystal in	
3	3	PA2/OSCOU	I/O	X	X	X		O1	X	X	Port A2	Resonator/crystal out	
4	-	V _{SSIO_1}	S									I/O ground	
5	4	V _{SS}	S									Digital ground	
6	5	VCAP	S									1.8 V regulator capacitor	
7	6	V _{DD}	S									Digital power supply	
8	7	V _{DDIO_1}	S									I/O power supply	
9	-	PA3/TIM2_CH3	I/O	X	X	X		O1	X	X	Port A3	Timer 2 - channel3	TIM3_CH1 [AFR1]
10	-	PA4	I/O	X	X	X	HS	O3	X	X	Port A4		
11	-	PA5	I/O	X	X	X	HS	O3	X	X	Port A5		
12	-	PA6	I/O	X	X	X	HS	O3	X	X	Port A6		
-	8	PF4/AIN12 ⁽¹⁾	I/O	X	X			O1	X	X	Port F4	Analog input 12 ⁽²⁾	
13	9	V _{DDA}	S									Analog power supply	
14	10	V _{SSA}	S									Analog ground	
15	-	PB7/AIN7	I/O	X	X	X		O1	X	X	Port B7	Analog input 7	
16	-	PB6/AIN6	I/O	X	X	X		O1	X	X	Port B6	Analog input 6	
17	11	PB5/AIN5 [I ² C_SDA]	I/O	X	X	X		O1	X	X	Port B5	Analog input 5	I ² C_SDA [AFR6]
18	12	PB4/AIN4 [I ² C_SCL]	I/O	X	X	X		O1	X	X	Port B4	Analog input 4	I ² C_SCL [AFR6]
19	13	PB3/AIN3 [TIM1_ETR]	I/O	X	X	X		O1	X	X	Port B3	Analog input 3	TIM1_ETR [AFR5]
20	14	PB2/AIN2 [TIM1_CH3N]	I/O	X	X	X		O1	X	X	Port B2	Analog input 2	TIM1_CH3N [AFR5]
21	15	PB1/AIN1 [TIM1_CH2N]	I/O	X	X	X		O1	X	X	Port B1	Analog input 1	TIM1_CH2N [AFR5]

Table 5. STM8S005C6 and STM8S005K6 pin descriptions (continued)

Pin number		Pin name	Type	Input			Output				Main function (after reset)	Default alternate function	Alternate function after remap [option bit]
LQFP48	LQFP32			floating	wpu	Ext. interrupt	High sink	Speed	OD	PP			
22	16	PB0/AIN0 [TIM1_CH1N]	I/O	X	X	X		O1	X	X	Port B0	Analog input 0	TIM1_CH1N [AFR5]
23	-	PE7/AIN8	I/O	X	X	X		O1	X	X	Port E7	Analog input 8	
24	-	PE6/AIN9	I/O	X	X	X		O1	X	X	Port E6	Analog input 9	
25	17	PE5/SPI_NSS	I/O	X	X	X		O1	X	X	Port E5	SPI master/slave select	
26	18	PC1/TIM1_CH1/ UART2_CK	I/O	X	X	X	HS	O3	X	X	Port C1	Timer 1 - channel 1/ UART2 synchronous clock	
27	19	PC2/TIM1_CH2	I/O	X	X	X	HS	O3	X	X	Port C2	Timer 1 - channel 2	
28	20	PC3/TIM1_CH3	I/O	X	X	X	HS	O3	X	X	Port C3	Timer 1 - channel 3	
29	21	PC4/TIM1_CH4	I/O	X	X	X	HS	O3	X	X	Port C4	Timer 1 - channel 4	
30	22	PC5/SPI_SCK	I/O	X	X	X	HS	O3	X	X	Port C5	SPI clock	
31	-	V _{SSIO_2}	S									I/O ground	
32	-	V _{DDIO_2}	S									I/O power supply	
33	23	PC6/SPI_MOSI	I/O	X	X	X	HS	O3	X	X	Port C6	SPI master out/slave in	
34	24	PC7/SPI_MISO	I/O	X	X	X	HS	O3	X	X	Port C7	SPI master in/slave out	
35	-	PG0	I/O	X	X			O1	X	X	Port G0		
36	-	PG1	I/O	X	X			O1	X	X	Port G1		
37	-	PE3/TIM1_BKIN	I/O	X	X	X		O1	X	X	Port E3	Timer 1 - break input	
38	-	PE2/I ² C_SDA	I/O	X		X		O1	T ⁽³⁾		Port E2	I ² C data	
39	-	PE1/I ² C_SCL	I/O	X		X		O1	T ⁽³⁾		Port E1	I ² C clock	
40	-	PE0/CLK_CCO	I/O	X	X	X	HS	O3	X	X	Port E0	Configurable clock output	

Table 5. STM8S005C6 and STM8S005K6 pin descriptions (continued)

Pin number		Pin name	Type	Input			Output				Main function (after reset)	Default alternate function	Alternate function after remap [option bit]
LQFP48	LQFP32			floating	wpu	Ext. interrupt	High sink	Speed	OD	PP			
41	25	PD0/TIM3_CH2 [TIM1_BKIN] [CLK_CCO]	I/O	X	X	X	HS	O3	X	X	Port D0	Timer 3 - channel 2	TIM1_BKIN [AFR3]/ CLK_CCO [AFR2]
42	26	PD1/SWIM ⁽⁴⁾	I/O	X	X	X	HS	O4	X	X	Port D1	SWIM data interface	
43	27	PD2/TIM3_CH1 [TIM2_CH3]	I/O	X	X	X	HS	O3	X	X	Port D2	Timer 3 - channel 1	TIM2_CH3 [AFR1]
44	28	PD3/TIM2_CH2 [ADC_ETR]	I/O	X	X	X	HS	O3	X	X	Port D3	Timer 2 - channel 2	ADC_ETR [AFR0]
45	29	PD4/TIM2_CH1 [BEEP]	I/O	X	X	X	HS	O3	X	X	Port D4	Timer 2 - channel 1	BEEP output [AFR7]
46	30	PD5/ UART2_TX	I/O	X	X	X		O1	X	X	Port D5	UART2 data transmit	
47	31	PD6/ UART2_RX	I/O	X	X	X		O1	X	X	Port D6	UART2 data receive	
48	32	PD7/TLI [TIM1_CH4]	I/O	X	X	X		O1	X	X	Port D7	Top level interrupt	TIM1_CH4 [AFR4]

1. A pull-up is applied to PF4 during the reset phase. This pin is input floating after reset release.
2. AIN12 is not selectable in ADC scan mode or with analog watchdog.
3. In the open-drain output column, 'T' defines a true open-drain I/O (P-buffer, weak pull-up, and protection diode to V_{DD} are not implemented).
4. The PD1 pin is in input pull-up during the reset phase and after the internal reset release.

5.1 Alternate function remapping

As shown in the rightmost column of the pin description table, some alternate functions can be remapped at different I/O ports by programming one of eight AFR (alternate function remap) option bits. Refer to [Section 8: Option bytes](#). When the remapping option is active, the default alternate function is no longer available.

To use an alternate function, the corresponding peripheral must be enabled in the peripheral registers.

Alternate function remapping does not effect GPIO capabilities of the I/O ports (see the GPIO section of the family reference manual, RM0016).

6 Memory and register map

6.1 Memory map

Figure 5. Memory map

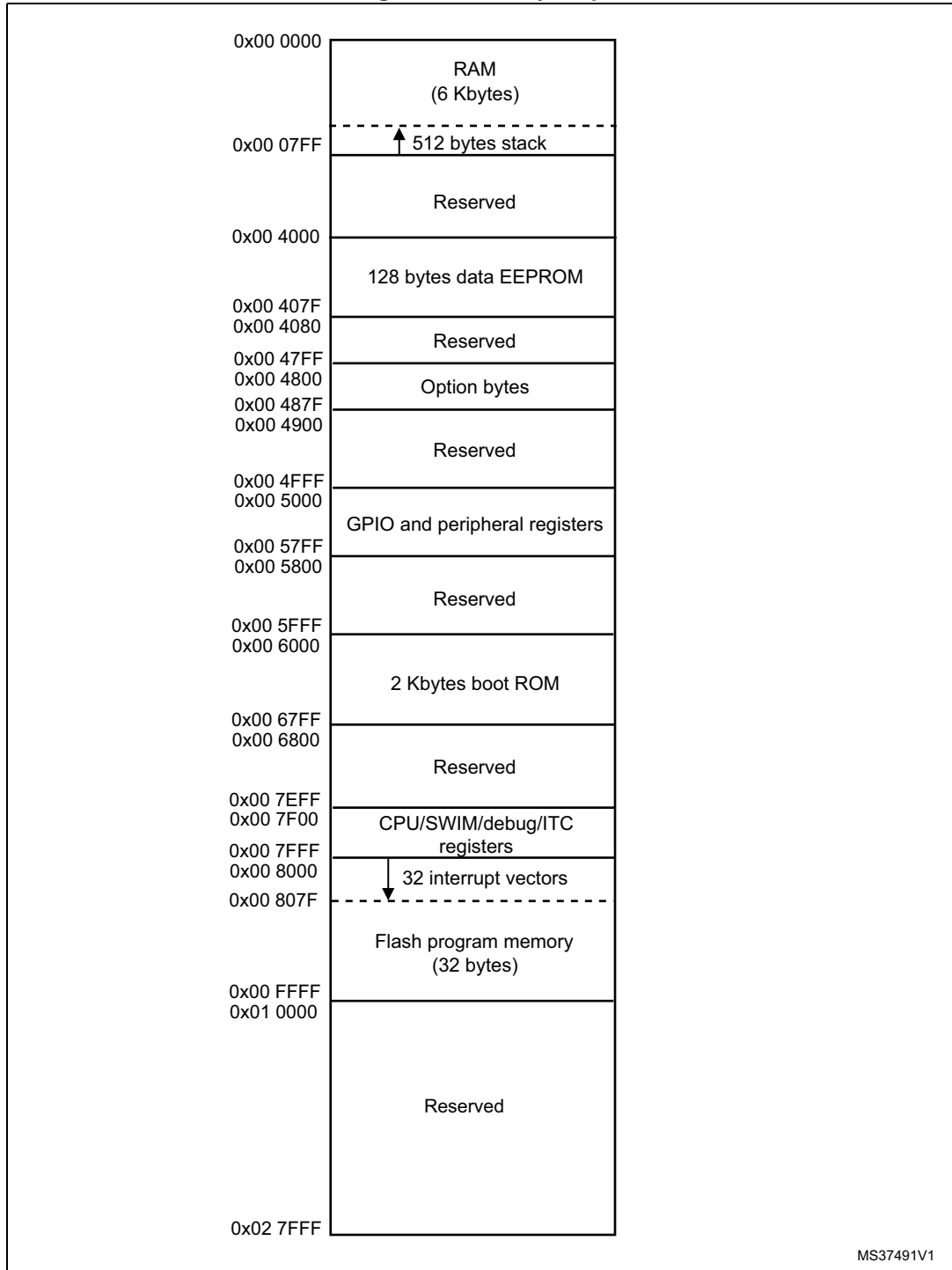

Table 6 lists the boundary addresses for each memory size. The top of the stack is at the RAM end address in each case.

Table 6. Flash, Data EEPROM and RAM boundary addresses

Memory area	Size (bytes)	Start address	End address
Flash program memory	32 K	0x00 8000	0x00 FFFF
RAM	2 K	0x00 0000	0x00 07FF
Data EEPROM	128	0x00 4000	0x00 407F

6.2 Register map

Table 7. I/O port hardware register map

Address	Block	Register label	Register name	Reset status
0x00 5000	Port A	PA_ODR	Port A data output latch register	0x00
0x00 5001		PA_IDR	Port A input pin value register	0xXX ⁽¹⁾
0x00 5002		PA_DDR	Port A data direction register	0x00
0x00 5003		PA_CR1	Port A control register 1	0x00
0x00 5004		PA_CR2	Port A control register 2	0x00
0x00 5005	Port B	PB_ODR	Port B data output latch register	0x00
0x00 5006		PB_IDR	Port B input pin value register	0xXX ⁽¹⁾
0x00 5007		PB_DDR	Port B data direction register	0x00
0x00 5008		PB_CR1	Port B control register 1	0x00
0x00 5009		PB_CR2	Port B control register 2	0x00
0x00 500A	Port C	PC_ODR	Port C data output latch register	0x00
0x00 500B		PC_IDR	Port C input pin value register	0xXX ⁽¹⁾
0x00 500C		PC_DDR	Port C data direction register	0x00
0x00 500D		PC_CR1	Port C control register 1	0x00
0x00 500E		PC_CR2	Port C control register 2	0x00
0x00 500F	Port D	PD_ODR	Port D data output latch register	0x00
0x00 5010		PD_IDR	Port D input pin value register	0xXX ⁽¹⁾
0x00 5011		PD_DDR	Port D data direction register	0x00
0x00 5012		PD_CR1	Port D control register 1	0x02
0x00 5013		PD_CR2	Port D control register 2	0x00

Table 7. I/O port hardware register map (continued)

Address	Block	Register label	Register name	Reset status
0x00 5014	Port E	PE_ODR	Port E data output latch register	0x00
0x00 5015		PE_IDR	Port E input pin value register	0xXX ⁽¹⁾
0x00 5016		PE_DDR	Port E data direction register	0x00
0x00 5017		PE_CR1	Port E control register 1	0x00
0x00 5018		PE_CR2	Port E control register 2	0x00
0x00 5019	Port F	PF_ODR	Port F data output latch register	0x00
0x00 501A		PF_IDR	Port F input pin value register	0xXX ⁽¹⁾
0x00 501B		PF_DDR	Port F data direction register	0x00
0x00 501C		PF_CR1	Port F control register 1	0x00
0x00 501D		PF_CR2	Port F control register 2	0x00
0x00 501E	Port G	PG_ODR	Port G data output latch register	0x00
0x00 501F		PG_IDR	Port G input pin value register	0xXX ⁽¹⁾
0x00 5020		PG_DDR	Port G data direction register	0x00
0x00 5021		PG_CR1	Port G control register 1	0x00
0x00 5022		PG_CR2	Port G control register 2	0x00
0x00 5023	Port H	PH_ODR	Port H data output latch register	0x00
0x00 5024		PH_IDR	Port H input pin value register	0xXX ⁽¹⁾
0x00 5025		PH_DDR	Port H data direction register	0x00
0x00 5026		PH_CR1	Port H control register 1	0x00
0x00 5027		PH_CR2	Port H control register 2	0x00
0x00 5028	Port I	PI_ODR	Port I data output latch register	0x00
0x00 5029		PI_IDR	Port I input pin value register	0xXX ⁽¹⁾
0x00 502A		PI_DDR	Port I data direction register	0x00
0x00 502B		PI_CR1	Port I control register 1	0x00
0x00 502C		PI_CR2	Port I control register 2	0x00

1. Depends on the external circuitry.

Table 8. General hardware register map

Address	Block	Register label	Register name	Reset status
0x00 5050 to 0x00 5059	Reserved area (10 bytes)			
0x00 505A	Flash	FLASH_CR1	Flash control register 1	0x00
0x00 505B		FLASH_CR2	Flash control register 2	0x00
0x00 505C		FLASH_NCR2	Flash complementary control register 2	0xFF
0x00 505D		FLASH_FPR	Flash protection register	0x00
0x00 505E		FLASH_NFPR	Flash complementary protection register	0xFF
0x00 505F		FLASH_IAPSR	Flash in-application programming status register	0x00
0x00 5060 to 0x00 5061	Reserved area (2 bytes)			
0x00 5062	Flash	FLASH_PUKR	Flash Program memory unprotection register	0x00
0x00 5063	Reserved area (1 byte)			
0x00 5064	Flash	FLASH_DUKR	Data EEPROM unprotection register	0x00
0x00 5065 to 0x00 509F	Reserved area (59 bytes)			
0x00 50A0	ITC	EXTI_CR1	External interrupt control register 1	0x00
0x00 50A1		EXTI_CR2	External interrupt control register 2	0x00
0x00 50A2 to 0x00 50B2	Reserved area (17 bytes)			
0x00 50B3	RST	RST_SR	Reset status register	0xFF ⁽¹⁾
0x00 50B4 to 0x00 50BF	Reserved area (12 bytes)			
0x00 50C0	CLK	CLK_ICKR	Internal clock control register	0x01
0x00 50C1		CLK_ECKR	External clock control register	0x00
0x00 50C2	Reserved area (1 byte)			
0x00 50C3	CLK	CLK_CMSR	Clock master status register	0xE1
0x00 50C4		CLK_SWR	Clock master switch register	0xE1
0x00 50C5		CLK_SWCR	Clock switch control register	0xFF
0x00 50C6		CLK_CKDIVR	Clock divider register	0x18
0x00 50C7		CLK_PCKENR1	Peripheral clock gating register 1	0xFF
0x00 50C8		CLK_CSSR	Clock security system register	0x00
0x00 50C9		CLK_CCOR	Configurable clock control register	0x00
0x00 50CA		CLK_PCKENR2	Peripheral clock gating register 2	0xFF
0x00 50CB	Reserved area (1 byte)			

Table 8. General hardware register map (continued)

Address	Block	Register label	Register name	Reset status
0x00 50CC	CLK	CLK_HSITRIMR	HSI clock calibration trimming register	0x00
0x00 50CD		CLK_SWIMCCR	SWIM clock control register	0bXXXX XXX0
0x00 50CE to 0x00 50D0	Reserved area (3 bytes)			
0x00 50D1	WWDG	WWDG_CR	WWDG control register	0x7F
0x00 50D2		WWDG_WR	WWDR window register	0x7F
0x00 50D3 to 0x00 50DF	Reserved area (13 bytes)			
0x00 50E0	IWDG	IWDG_KR	IWDG key register	0xXX ⁽²⁾
0x00 50E1		IWDG_PR	IWDG prescaler register	0x00
0x00 50E2		IWDG_RLR	IWDG reload register	0xFF
0x00 50E3 to 0x00 50EF	Reserved area (13 bytes)			
0x00 50F0	AWU	AWU_CSR1	AWU control/status register 1	0x00
0x00 50F1		AWU_APR	AWU asynchronous prescaler buffer register	0x3F
0x00 50F2		AWU_TBR	AWU timebase selection register	0x00
0x00 50F3	BEEP	BEEP_CSR	BEEP control/status register	0x1F
0x00 50F4 to 0x00 50FF	Reserved area (12 bytes)			
0x00 5200	SPI	SPI_CR1	SPI control register 1	0x00
0x00 5201		SPI_CR2	SPI control register 2	0x00
0x00 5202		SPI_ICR	SPI interrupt control register	0x00
0x00 5203		SPI_SR	SPI status register	0x02
0x00 5204		SPI_DR	SPI data register	0x00
0x00 5205		SPI_CRCPR	SPI CRC polynomial register	0x07
0x00 5206		SPI_RXCR	SPI Rx CRC register	0xFF
0x00 5207		SPI_TXCR	SPI Tx CRC register	0xFF
0x00 5208 to 0x00 520F	Reserved area (8 bytes)			
0x00 5210	I ² C	I2C_CR1	I ² C control register 1	0x00
0x00 5211		I2C_CR2	I ² C control register 2	0x00
0x00 5212		I2C_FREQR	I ² C frequency register	0x00
0x00 5213		I2C_OARL	I ² C own address register low	0x00
0x00 5214		I2C_OARH	I ² C own address register high	0x00
0x00 5215		Reserved		

Table 8. General hardware register map (continued)

Address	Block	Register label	Register name	Reset status
0x00 5216	I ² C	I2C_DR	I ² C data register	0x00
0x00 5217		I2C_SR1	I ² C status register 1	0x00
0x00 5218		I2C_SR2	I ² C status register 2	0x00
0x00 5219		I2C_SR3	I ² C status register 3	0x00
0x00 521A		I2C_ITR	I ² C interrupt control register	0x00
0x00 521B		I2C_CCRL	I ² C clock control register low	0x00
0x00 521C		I2C_CCRH	I ² C clock control register high	0x00
0x00 521D		I2C_TRISER	I ² C TRISE register	0x02
0x00 521E		I2C_PECR	I ² C packet error checking register	0x00
0x00 521F to 0x00 522F	Reserved area (17 bytes)			
0x00 5230 to 0x00 523F	Reserved area (6 bytes)			
0x00 5240	UART2	UART2_SR	UART2 status register	0xC0
0x00 5241		UART2_DR	UART2 data register	0xFF
0x00 5242		UART2_BRR1	UART2 baud rate register 1	0x00
0x00 5243		UART2_BRR2	UART2 baud rate register 2	0x00
0x00 5244		UART2_CR1	UART2 control register 1	0x00
0x00 5245		UART2_CR2	UART2 control register 2	0x00
0x00 5246		UART2_CR3	UART2 control register 3	0x00
0x00 5247		UART2_CR4	UART2 control register 4	0x00
0x00 5248		UART2_CR5	UART2 control register 5	0x00
0x00 5249		UART2_CR6	UART2 control register 6	0x00
0x00 524A		UART2_GTR	UART2 guard time register	0x00
0x00 524B		UART2_PSCR	UART2 prescaler register	0x00
0x00 524C to 0x00 524F	Reserved area (4 bytes)			

Table 8. General hardware register map (continued)

Address	Block	Register label	Register name	Reset status
0x00 5250	TIM1	TIM1_CR1	TIM1 control register 1	0x00
0x00 5251		TIM1_CR2	TIM1 control register 2	0x00
0x00 5252		TIM1_SMCR	TIM1 slave mode control register	0x00
0x00 5253		TIM1_ETR	TIM1 external trigger register	0x00
0x00 5254		TIM1_IER	TIM1 Interrupt enable register	0x00
0x00 5255		TIM1_SR1	TIM1 status register 1	0x00
0x00 5256		TIM1_SR2	TIM1 status register 2	0x00
0x00 5257		TIM1_EGR	TIM1 event generation register	0x00
0x00 5258		TIM1_CCMR1	TIM1 capture/compare mode register 1	0x00
0x00 5259		TIM1_CCMR2	TIM1 capture/compare mode register 2	0x00
0x00 525A		TIM1_CCMR3	TIM1 capture/compare mode register 3	0x00
0x00 525B		TIM1_CCMR4	TIM1 capture/compare mode register 4	0x00
0x00 525C		TIM1_CCER1	TIM1 capture/compare enable register 1	0x00
0x00 525D		TIM1_CCER2	TIM1 capture/compare enable register 2	0x00
0x00 525E		TIM1_CNTRH	TIM1 counter high	0x00
0x00 525F		TIM1_CNTRL	TIM1 counter low	0x00
0x00 5260		TIM1_PSCRH	TIM1 prescaler register high	0x00
0x00 5261		TIM1_PSCRL	TIM1 prescaler register low	0x00
0x00 5262		TIM1_ARRH	TIM1 auto-reload register high	0xFF
0x00 5263		TIM1_ARRL	TIM1 auto-reload register low	0xFF
0x00 5264		TIM1_RCR	TIM1 repetition counter register	0x00
0x00 5265		TIM1_CCR1H	TIM1 capture/compare register 1 high	0x00
0x00 5266		TIM1_CCR1L	TIM1 capture/compare register 1 low	0x00
0x00 5267		TIM1_CCR2H	TIM1 capture/compare register 2 high	0x00
0x00 5268		TIM1_CCR2L	TIM1 capture/compare register 2 low	0x00
0x00 5269		TIM1_CCR3H	TIM1 capture/compare register 3 high	0x00
0x00 526A		TIM1_CCR3L	TIM1 capture/compare register 3 low	0x00
0x00 526B		TIM1_CCR4H	TIM1 capture/compare register 4 high	0x00
0x00 526C		TIM1_CCR4L	TIM1 capture/compare register 4 low	0x00
0x00 526D		TIM1_BKR	TIM1 break register	0x00
0x00 526E	TIM1_DTR	TIM1 dead-time register	0x00	
0x00 526F	TIM1_OISR	TIM1 output idle state register	0x00	
0x00 5270 to 0x00 52FF	Reserved area (147 bytes)			

Table 8. General hardware register map (continued)

Address	Block	Register label	Register name	Reset status
0x00 5300	TIM2	TIM2_CR1	TIM2 control register 1	0x00
0x00 5301		TIM2_IER	TIM2 interrupt enable register	0x00
0x00 5302		TIM2_SR1	TIM2 status register 1	0x00
0x00 5303		TIM2_SR2	TIM2 status register 2	0x00
0x00 5304		TIM2_EGR	TIM2 event generation register	0x00
0x00 5305		TIM2_CCMR1	TIM2 capture/compare mode register 1	0x00
0x00 5306		TIM2_CCMR2	TIM2 capture/compare mode register 2	0x00
0x00 5307		TIM2_CCMR3	TIM2 capture/compare mode register 3	0x00
0x00 5308		TIM2_CCER1	TIM2 capture/compare enable register 1	0x00
0x00 5309		TIM2_CCER2	TIM2 capture/compare enable register 2	0x00
0x00 530A		TIM2_CNTRH	TIM2 counter high	0x00
0x00 530B		TIM2_CNTRL	TIM2 counter low	0x00
00 530C0x		TIM2_PSCR	TIM2 prescaler register	0x00
0x00 530D		TIM2_ARRH	TIM2 auto-reload register high	0xFF
0x00 530E		TIM2_ARRL	TIM2 auto-reload register low	0xFF
0x00 530F		TIM2_CCR1H	TIM2 capture/compare register 1 high	0x00
0x00 5310		TIM2_CCR1L	TIM2 capture/compare register 1 low	0x00
0x00 5311		TIM2_CCR2H	TIM2 capture/compare reg. 2 high	0x00
0x00 5312		TIM2_CCR2L	TIM2 capture/compare register 2 low	0x00
0x00 5313		TIM2_CCR3H	TIM2 capture/compare register 3 high	0x00
0x00 5314	TIM2_CCR3L	TIM2 capture/compare register 3 low	0x00	
0x00 5315 to 0x00 531F	Reserved area (11 bytes)			
0x00 5320	TIM3	TIM3_CR1	TIM3 control register 1	0x00
0x00 5321		TIM3_IER	TIM3 interrupt enable register	0x00
0x00 5322		TIM3_SR1	TIM3 status register 1	0x00
0x00 5323		TIM3_SR2	TIM3 status register 2	0x00
0x00 5324		TIM3_EGR	TIM3 event generation register	0x00
0x00 5325		TIM3_CCMR1	TIM3 capture/compare mode register 1	0x00
0x00 5326		TIM3_CCMR2	TIM3 capture/compare mode register 2	0x00
0x00 5327		TIM3_CCER1	TIM3 capture/compare enable register 1	0x00
0x00 5328		TIM3_CNTRH	TIM3 counter high	0x00
0x00 5329		TIM3_CNTRL	TIM3 counter low	0x00
0x00 532A		TIM3_PSCR	TIM3 prescaler register	0x00

Table 8. General hardware register map (continued)

Address	Block	Register label	Register name	Reset status
0x00 532B	TIM3	TIM3_ARRH	TIM3 auto-reload register high	0xFF
0x00 532C		TIM3_ARRL	TIM3 auto-reload register low	0xFF
0x00 532D		TIM3_CCR1H	TIM3 capture/compare register 1 high	0x00
0x00 532E		TIM3_CCR1L	TIM3 capture/compare register 1 low	0x00
0x00 532F		TIM3_CCR2H	TIM3 capture/compare register 2 high	0x00
0x00 5330		TIM3_CCR2L	TIM3 capture/compare register 2 low	0x00
0x00 5331 to 0x00 533F		Reserved area (15 bytes)		
0x00 5340	TIM4	TIM4_CR1	TIM4 control register 1	0x00
0x00 5341		TIM4_IER	TIM4 interrupt enable register	0x00
0x00 5342		TIM4_SR	TIM4 status register	0x00
0x00 5343		TIM4_EGR	TIM4 event generation register	0x00
0x00 5344		TIM4_CNTR	TIM4 counter	0x00
0x00 5345		TIM4_PSCR	TIM4 prescaler register	0x00
0x00 5346		TIM4_ARR	TIM4 auto-reload register	0xFF
0x00 5347 to 0x00 53FF	Reserved area (185 bytes)			
0x00 5400	ADC1	ADC_CSR	ADC control/status register	0x00
0x00 5401		ADC_CR1	ADC configuration register 1	0x00
0x00 5402		ADC_CR2	ADC configuration register 2	0x00
0x00 5403		ADC_CR3	ADC configuration register 3	0x00
0x00 5404		ADC_DRH	ADC data register high	0xFF
0x00 5405		ADC_DRL	ADC data register low	0xFF
0x00 5406		ADC_TDRH	ADC Schmitt trigger disable register high	0x00
0x00 5407		ADC_TDRL	ADC Schmitt trigger disable register low	0x00
0x00 5408		ADC_HTRH	ADC high threshold register high	0x03
0x00 5409		ADC_HTRL	ADC high threshold register low	0xFF
0x00 540A		ADC_LTRH	ADC low threshold register high	0x00
0x00 540B		ADC_LTRL	ADC low threshold register low	0x00
0x00 540C		ADC_AWSRH	ADC analog watchdog status register high	0x00
0x00 540D		ADC_AWSRL	ADC analog watchdog status register low	0x00
0x00 540E		ADC_AWCRH	ADC analog watchdog control register high	0x00
0x00 540F		ADC_AWCRL	ADC analog watchdog control register low	0x00
0x00 5410 to 0x00 57FF	Reserved area (1008 bytes)			

1. Depends on the previous reset source.
2. Write only register.

Table 9. CPU/SWIM/debug module/interrupt controller registers

Address	Block	Register Label	Register Name	Reset Status
0x00 7F00	CPU ⁽¹⁾	A	Accumulator	0x00
0x00 7F01		PCE	Program counter extended	0x00
0x00 7F02		PCH	Program counter high	0x00
0x00 7F03		PCL	Program counter low	0x00
0x00 7F04		XH	X index register high	0x00
0x00 7F05		XL	X index register low	0x00
0x00 7F06		YH	Y index register high	0x00
0x00 7F07		YL	Y index register low	0x00
0x00 7F08		SPH	Stack pointer high	0x17
0x00 7F09		SPL	Stack pointer low	0xFF
0x00 7F0A		CCR	Condition code register	0x28
0x00 7F0B to 0x00 7F5F		Reserved area (85 bytes)		
0x00 7F60	CPU	CFG_GCR	Global configuration register	0x00
0x00 7F70	ITC	ITC_SPR1	Interrupt software priority register 1	0xFF
0x00 7F71		ITC_SPR2	Interrupt software priority register 2	0xFF
0x00 7F72		ITC_SPR3	Interrupt software priority register 3	0xFF
0x00 7F73		ITC_SPR4	Interrupt software priority register 4	0xFF
0x00 7F74		ITC_SPR5	Interrupt software priority register 5	0xFF
0x00 7F75		ITC_SPR6	Interrupt software priority register 6	0xFF
0x00 7F76		ITC_SPR7	Interrupt software priority register 7	0xFF
0x00 7F77		ITC_SPR8	Interrupt software priority register 8	0xFF
0x00 7F78 to 0x00 7F79	Reserved area (2 bytes)			
0x00 7F80	SWIM	SWIM_CSR	SWIM control status register	0x00
0x00 7F81 to 0x00 7F8F	Reserved area (15 bytes)			

Table 9. CPU/SWIM/debug module/interrupt controller registers (continued)

Address	Block	Register Label	Register Name	Reset Status
0x00 7F90	DM	DM_BK1RE	DM breakpoint 1 register extended byte	0xFF
0x00 7F91		DM_BK1RH	DM breakpoint 1 register high byte	0xFF
0x00 7F92		DM_BK1RL	DM breakpoint 1 register low byte	0xFF
0x00 7F93		DM_BK2RE	DM breakpoint 2 register extended byte	0xFF
0x00 7F94		DM_BK2RH	DM breakpoint 2 register high byte	0xFF
0x00 7F95		DM_BK2RL	DM breakpoint 2 register low byte	0xFF
0x00 7F96		DM_CR1	DM debug module control register 1	0x00
0x00 7F97		DM_CR2	DM debug module control register 2	0x00
0x00 7F98		DM_CSR1	DM debug module control/status register 1	0x10
0x00 7F99		DM_CSR2	DM debug module control/status register 2	0x00
0x00 7F9A		DM_ENFCTR	DM enable function register	0xFF
0x00 7F9B to 0x00 7F9F		Reserved area (5 bytes)		

1. Accessible by debug module only

7 Interrupt vector mapping

Table 10. Interrupt mapping

IRQ no.	Source block	Description	Wakeup from Halt mode	Wakeup from Active-halt mode	Vector address
-	RESET	Reset	Yes	Yes	0x00 8000
-	TRAP	Software interrupt	-	-	0x00 8004
0	TLI	External top level interrupt	-	-	0x00 8008
1	AWU	Auto wake up from halt	-	Yes	0x00 800C
2	CLK	Clock controller	-	-	0x00 8010
3	EXTI0	Port A external interrupts	Yes ⁽¹⁾	Yes ⁽¹⁾	0x00 8014
4	EXTI1	Port B external interrupts	Yes	Yes	0x00 8018
5	EXTI2	Port C external interrupts	Yes	Yes	0x00 801C
6	EXTI3	Port D external interrupts	Yes	Yes	0x00 8020
7	EXTI4	Port E external interrupts	Yes	Yes	0x00 8024
8	Reserved				0x00 8028
9	Reserved				0x00 802C
10	SPI	End of transfer	Yes	Yes	0x00 8030
11	TIM1	TIM1 update/overflow/underflow/trigger/break	-	-	0x00 8034
12	TIM1	TIM1 capture/compare	-	-	0x00 8038
13	TIM2	TIM2 update /overflow	-	-	0x00 803C
14	TIM2	TIM2 capture/compare	-	-	0x00 8040
15	TIM3	Update/overflow	-	-	0x00 8044
16	TIM3	Capture/compare	-	-	0x00 8048
17	-	Reserved	-	-	0x00 804C
18	-	Reserved	-	-	0x00 8050
19	I ² C	I ² C interrupt	Yes	Yes	0x00 8054
20	UART2	Tx complete	-	-	0x00 8058
21	UART2	Receive register DATA FULL	-	-	0x00 805C
22	ADC1	ADC1 end of conversion/analog watchdog interrupt	-	-	0x00 8060
23	TIM4	TIM4 update/overflow	-	-	0x00 8064
24	Flash	EOP/WR_PG_DIS	-	-	0x00 8068
Reserved					0x00 806C to 0x00 807C

1. Except PA1

8 Option bytes

Option bytes contain configurations for device hardware features as well as the memory protection of the device. They are stored in a dedicated block of the memory. Except for the ROP (read-out protection) byte, each option byte has to be stored twice, in a regular form (OPTx) and a complemented one (NOPTx) for redundancy.

Option bytes can be modified in ICP mode (via SWIM) by accessing the EEPROM address shown in [Table 11: Option bytes](#) below. Option bytes can also be modified 'on the fly' by the application in IAP mode, except the ROP option that can only be modified in ICP mode (via SWIM).

Refer to the STM8S Flash programming manual (PM0051) and STM8 SWIM communication protocol and debug module user manual (UM0470) for information on SWIM programming procedures.

Table 11. Option bytes

Addr.	Option name	Option byte no.	Option bits								Factory default setting
			7	6	5	4	3	2	1	0	
4800h	Read-out protection (ROP)	OPT0	ROP[7:0]								00h
4801h	User boot code (UBC)	OPT1	UBC[7:0]								00h
4802h		NOPT1	NUBC[7:0]								FFh
4803h	Alternate function remapping (AFR)	OPT2	AFR7	AFR6	AFR5	Reserved	AFR3	AFR2	AFR1	AFR0	00h
4804h		NOPT2	NAFR7	NAFR6	NAFR5	NAFR4	NAFR3	NAFR2	NAFR1	NAFR0	FFh
4805h	Miscellaneous option	OPT3	Reserved			HSITRIM	LSI_EN	IWDG_HW	WWDG_HW	WWDG_HALT	00h
4806h		NOPT3	Reserved			NHSI TRIM	NLSI_EN	NIWDG_HW	NWWDG_HW	NWWDG_HALT	FFh
4807h	Clock option	OPT4	Reserved				EXT CLK	CKAWU SEL	PRSC1	PRSC0	00h
4808h		NOPT4	Reserved				NEXT CLK	NCKAWU SEL	NPRSC1	NPRSC0	FFh
4809h	HSE clock startup	OPT5	HSECNT[7:0]								00h
480Ah		NOPT5	NHSECNT[7:0]								FFh
480Bh	Reserved	OPT6	Reserved								00h
480Ch		NOPT6	Reserved								FFh
480Dh	Flash wait states	OPT7	Reserved								00h
480Eh		NOPT7	Reserved								FFh
487Eh	Bootloader	OPTBL	BL[7:0]								00h
487Fh		NOPTBL	NBL[7:0]								FFh

Table 12. Option byte description

Option byte no.	Description
OPT0	<p>ROP[7:0] <i>Memory readout protection (ROP)</i> 0xAA: Enable readout protection (write access via SWIM protocol) <i>Note: Refer to the family reference manual (RM0016) section on Flash/EEPROM memory readout protection for details.</i></p>
OPT1	<p>UBC[7:0] <i>User boot code area</i> 0x00: no UBC, no write-protection 0x01: Pages 0 to 1 defined as UBC, memory write-protected 0x02: Pages 0 to 3 defined as UBC, memory write-protected 0x03: Pages 0 to 4 defined as UBC, memory write-protected ... 0xFE: Pages 0 to 255 defined as UBC, memory write-protected 0xFF: Reserved <i>Note: Refer to the family reference manual (RM0016) section on Flash/EEPROM write protection for more details.</i></p>
OPT2	<p>AFR[7:0] Refer to Table 13: Description of alternate function remapping bits [7:0] of OPT2</p>
OPT3	<p>HSITRIM: high-speed internal clock trimming register size 0: 3-bit trimming supported in CLK_HSITRIMR register 1: 4-bit trimming supported in CLK_HSITRIMR register</p> <p>LSI_EN: <i>Low speed internal clock enable</i> 0: LSI clock is not available as CPU clock source 1: LSI clock is available as CPU clock source</p> <p>IWDG_HW: <i>Independent watchdog</i> 0: IWDG Independent watchdog activated by software 1: IWDG Independent watchdog activated by hardware</p> <p>WWDG_HW: <i>Window watchdog activation</i> 0: WWDG window watchdog activated by software 1: WWDG window watchdog activated by hardware</p> <p>WWDG_HALT: <i>Window watchdog reset on halt</i> 0: No reset generated on halt if WWDG active 1: Reset generated on halt if WWDG active</p>
OPT4	<p>EXTCLK: <i>External clock selection</i> 0: External crystal connected to OSCIN/OSCOUT 1: External clock signal on OSCIN</p> <p>CKAWUSEL: <i>Auto wakeup unit/clock</i> 0: LSI clock source selected for AWU 1: HSE clock with prescaler selected as clock source for for AWU</p> <p>PRSC[1:0] AWU clock prescaler 0x: 16 MHz to 128 kHz prescaler 10: 8 MHz to 128 kHz prescaler 11: 4 MHz to 128 kHz prescaler</p>

Table 12. Option byte description (continued)

Option byte no.	Description
OPT5	<p>HSECNT[7:0]: HSE crystal oscillator stabilization time This configures the stabilization time. 0x00: 2048 HSE cycles 0xB4: 128 HSE cycles 0xD2: 8 HSE cycles 0xE1: 0.5 HSE cycles</p>
OPT6	Reserved
OPT7	Reserved
OPTBL	<p>BL[7:0] Bootloader option byte For STM8S products, this option is checked by the boot ROM code after reset. Depending on the content of addresses 0x487E, 0x487F, and 0x8000 (reset vector), the CPU jumps to the bootloader or to the reset vector. Refer to the UM0560 (STM8L/S bootloader manual) for more details. For STM8L products, the bootloader option bytes are on addresses 0XXXX and 0XXXX+1 (2 bytes). These option bytes control whether the bootloader is active or not. For more details, refer to the UM0560 (STM8L/S bootloader manual) for more details.</p>

Table 13. Description of alternate function remapping bits [7:0] of OPT2

Option byte number	Description ⁽¹⁾
OPT2	<p>AFR7 <i>Alternate function remapping option 7</i> 0: AFR7 remapping option inactive: default alternate function⁽²⁾ 1: Port D4 alternate function = BEEP</p> <p>AFR6 <i>Alternate function remapping option 6</i> 0: AFR6 remapping option inactive: default alternate function⁽²⁾ 1: Port B5 alternate function = I²C_SDA; port B4 alternate function = I²C_SCL</p> <p>AFR5 <i>Alternate function remapping option 5</i> 0: AFR5 remapping option inactive: default alternate function⁽²⁾ 1: Port B3 alternate function = TIM1_ETR, port B2 alternate function = TIM1_CH3N, port B1 alternate function = TIM1_CH2N, port B0 alternate function = TIM1_CH1N</p> <p>AFR4 <i>Alternate function remapping option 4</i> 0: AFR4 remapping option inactive: default alternate function⁽²⁾ 1: Port D alternate function = TIM1_CH4</p> <p>AFR3 <i>Alternate function remapping option 3</i> 0: AFR3 remapping option inactive: default alternate function⁽²⁾ 1: Port D0 alternate function = TIM1_BKIN</p> <p>AFR2 <i>Alternate function remapping option 2</i> 0: AFR2 remapping option inactive: default alternate function⁽²⁾ 1: Port D0 alternate function = CLK_CCO Note: AFR2 option has priority over AFR3 if both are activated</p> <p>AFR1 <i>Alternate function remapping option 1</i> 0: AFR1 remapping option inactive: default alternate function⁽²⁾ 1: Port A3 alternate function = TIM3_CH1; port D2 alternate function = TIM2_CH3</p> <p>AFR0 <i>Alternate function remapping option 0</i> 0: AFR0 remapping option inactive: default alternate function⁽²⁾ 1: Port D3 alternate function = ADC_ETR</p>

1. Do not use more than one remapping option in the same port.
2. Refer to the pinout description.

9 Electrical characteristics

9.1 Parameter conditions

Unless otherwise specified, all voltages are referred to V_{SS} .

9.1.1 Minimum and maximum values

Unless otherwise specified the minimum and maximum values are guaranteed in the worst conditions of ambient temperature, supply voltage and frequencies by tests in production on 100% of the devices with an ambient temperature at $T_A = 25\text{ °C}$ and $T_A = T_{Amax}$ (given by the selected temperature range).

Data based on characterization results, design simulation and/or technology characteristics are indicated in the table footnotes and are not tested in production. Based on characterization, the minimum and maximum values refer to sample tests and represent the mean value plus or minus three times the standard deviation (mean $\pm 3\sigma$).

9.1.2 Typical values

Unless otherwise specified, typical data are based on $T_A = 25\text{ °C}$, $V_{DD} = 5\text{ V}$. They are given only as design guidelines and are not tested.

Typical ADC accuracy values are determined by characterization of a batch of samples from a standard diffusion lot over the full temperature range, where 95% of the devices have an error less than or equal to the value indicated (mean $\pm 2\sigma$).

9.1.3 Typical curves

Unless otherwise specified, all typical curves are given only as design guidelines and are not tested.

9.1.4 Typical current consumption

For typical current consumption measurements, V_{DD} , V_{DDIO} and V_{DDA} are connected together in the configuration shown in [Figure 6](#).

Figure 6. Supply current measurement conditions

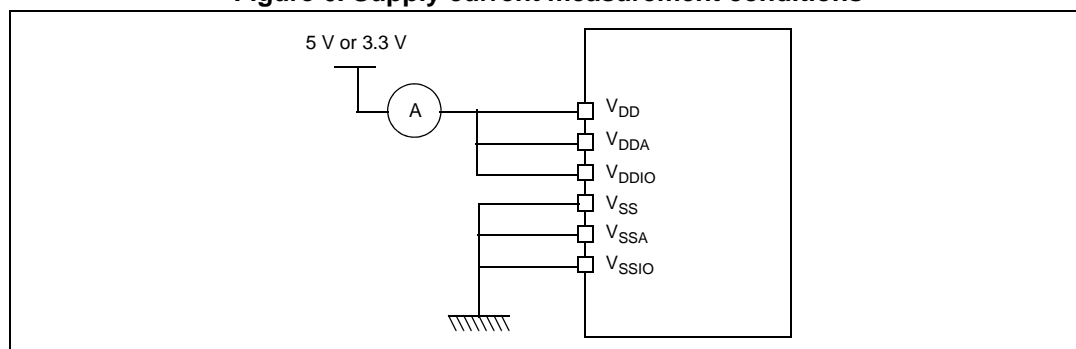

9.1.5 Pin loading conditions

9.1.6 Loading capacitor

The loading conditions used for pin parameter measurement are shown in [Figure 7](#).

Figure 7. Pin loading conditions

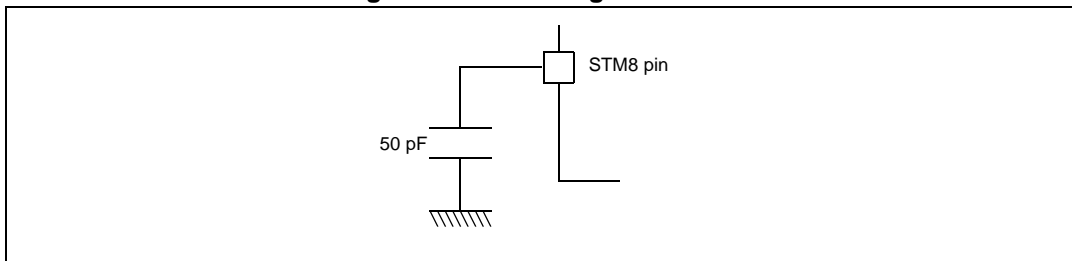

9.1.7 Pin input voltage

The input voltage measurement on a pin of the device is described in [Figure 8](#).

Figure 8. Pin input voltage

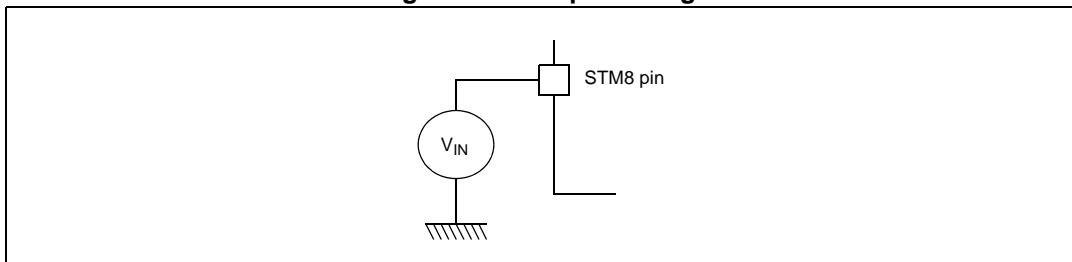

9.2 Absolute maximum ratings

Stresses above those listed as ‘absolute maximum ratings’ may cause permanent damage to the device. This is a stress rating only and functional operation of the device under these conditions is not implied. Exposure to maximum rating conditions for extended periods may affect device reliability.

Table 14. Voltage characteristics

Symbol	Ratings	Min	Max	Unit
$V_{DDX} - V_{SS}$	Supply voltage (including V_{DDA} and V_{DDIO}) ⁽¹⁾	-0.3	6.5	V
V_{IN}	Input voltage on true open drain pins (PE1, PE2) ⁽²⁾	$V_{SS} - 0.3$	6.5	
	Input voltage on any other pin ⁽²⁾	$V_{SS} - 0.3$	$V_{DD} + 0.3$	
$ V_{DDX} - V_{DD} $	Variations between different power pins	-	50	mV
$ V_{SSX} - V_{SS} $	Variations between all the different ground pins	-	50	
V_{ESD}	Electrostatic discharge voltage	see Absolute maximum ratings (electrical sensitivity) on page 83		-

1. All power (V_{DD} , V_{DDIO} , V_{DDA}) and ground (V_{SS} , V_{SSIO} , V_{SSA}) pins must always be connected to the external power supply
2. $I_{INJ(PIN)}$ must never be exceeded. This is implicitly insured if V_{IN} maximum is respected. If V_{IN} maximum cannot be respected, the injection current must be limited externally to the $I_{INJ(PIN)}$ value. A positive injection is induced by $V_{IN} > V_{DD}$ while a negative injection is induced by $V_{IN} < V_{SS}$. For true open-drain pads, there is no positive injection current, and the corresponding V_{IN} maximum must always be respected

Table 15. Current characteristics

Symbol	Ratings	Max. ⁽¹⁾	Unit
I_{VDD}	Total current into V_{DD} power lines (source) ⁽²⁾	60	mA
I_{VSS}	Total current out of V_{SS} ground lines (sink) ⁽²⁾	60	
I_{IO}	Output current sunk by any I/O and control pin	20	
	Output current source by any I/Os and control pin	20	
ΣI_{IO}	Total output current sourced (sum of all I/O and control pins) for devices with two V_{DDIO} pins ⁽³⁾	200	
	Total output current sourced (sum of all I/O and control pins) for devices with one V_{DDIO} pin ⁽³⁾	100	
	Total output current sunk (sum of all I/O and control pins) for devices with two V_{SSIO} pins ⁽³⁾	160	
	Total output current sunk (sum of all I/O and control pins) for devices with one V_{SSIO} pin ⁽³⁾	80	
$I_{INJ(PIN)}$ ⁽⁴⁾⁽⁵⁾	Injected current on NRST pin	±4	
	Injected current on OSCIN pin	±4	
	Injected current on any other pin ⁽⁶⁾	±4	
$\Sigma I_{INJ(PIN)}$ ⁽⁴⁾	Total injected current (sum of all I/O and control pins) ⁽⁶⁾	±20	

1. Data based on characterization results, not tested in production.
2. All power (V_{DD} , V_{DDIO} , V_{DDA}) and ground (V_{SS} , V_{SSIO} , V_{SSA}) pins must always be connected to the external supply.
3. I/O pins used simultaneously for high current source/sink must be uniformly spaced around the package between the V_{DDIO}/V_{SSIO} pins.
4. $I_{INJ(PIN)}$ must never be exceeded. This is implicitly insured if V_{IN} maximum is respected. If V_{IN} maximum cannot be respected, the injection current must be limited externally to the $I_{INJ(PIN)}$ value. A positive injection is induced by $V_{IN} > V_{DD}$ while a negative injection is induced by $V_{IN} < V_{SS}$. For true open-drain pads, there is no positive injection current, and the corresponding V_{IN} maximum must always be respected
5. Negative injection disturbs the analog performance of the device. See note in [Section 9.3.10: 10-bit ADC characteristics on page 79](#).
6. When several inputs are submitted to a current injection, the maximum $\Sigma I_{INJ(PIN)}$ is the absolute sum of the positive and negative injected currents (instantaneous values). These results are based on characterization with $\Sigma I_{INJ(PIN)}$ maximum current injection on four I/O port pins of the device.

Table 16. Thermal characteristics

Symbol	Ratings	Value	Unit
T_{STG}	Storage temperature range	-65 to 150	°C
T_J	Maximum junction temperature	150	

9.3 Operating conditions

The device must be used in operating conditions that respect the parameters in [Table 17](#). In addition, full account must be taken of all physical capacitor characteristics and tolerances.

Table 17. General operating conditions

Symbol	Parameter	Conditions	Min	Max	Unit
f_{CPU}	Internal CPU clock frequency	-	0	16	MHz
$V_{\text{DD}}/V_{\text{DD_IO}}$	Standard operating voltage	-	2.95	5.5	V
$V_{\text{CAP}}^{(1)}$	C_{EXT} : capacitance of external capacitor	-	470	3300	nF
	ESR of external capacitor	At 1 MHz ⁽²⁾	-	0.3	ohm
	ESL of external capacitor		-	15	nH
$P_{\text{D}}^{(3)}$	Power dissipation at $T_{\text{A}} = 85^{\circ}\text{C}$ for suffix 6	48-pin devices, with output on eight standard ports, two high sink ports and two open drain ports simultaneously ⁽⁴⁾	-	443	mW
		32-pin devices, with output on eight standard ports and two high sink ports simultaneously ⁽⁴⁾	-	360	mW
T_{A}	Ambient temperature for 6 suffix version	Maximum power dissipation	-40	85	°C
T_{J}	Junction temperature range	-	-40	105	

- Care should be taken when selecting the capacitor, due to its tolerance, as well as the parameter dependency on temperature, DC bias and frequency in addition to other factors. The parameter specifications must be respected for the full application range.
- This frequency of 1 MHz as a condition for V_{CAP} parameters is given by the design of the internal regulator.
- To calculate $P_{\text{Dmax}}(T_{\text{A}})$, use the formula $P_{\text{Dmax}} = (T_{\text{Jmax}} - T_{\text{A}})/\Theta_{\text{JA}}$ (see [Section 10.3: Thermal characteristics on page 91](#)) with the value for T_{Jmax} given in [Table 17](#) above and the value for Θ_{JA} given in [Table 52: Thermal characteristics](#).
- Refer to [Section 10.3: Thermal characteristics on page 91](#) for the calculation method.

Figure 9. f_{CPUmax} versus V_{DD}

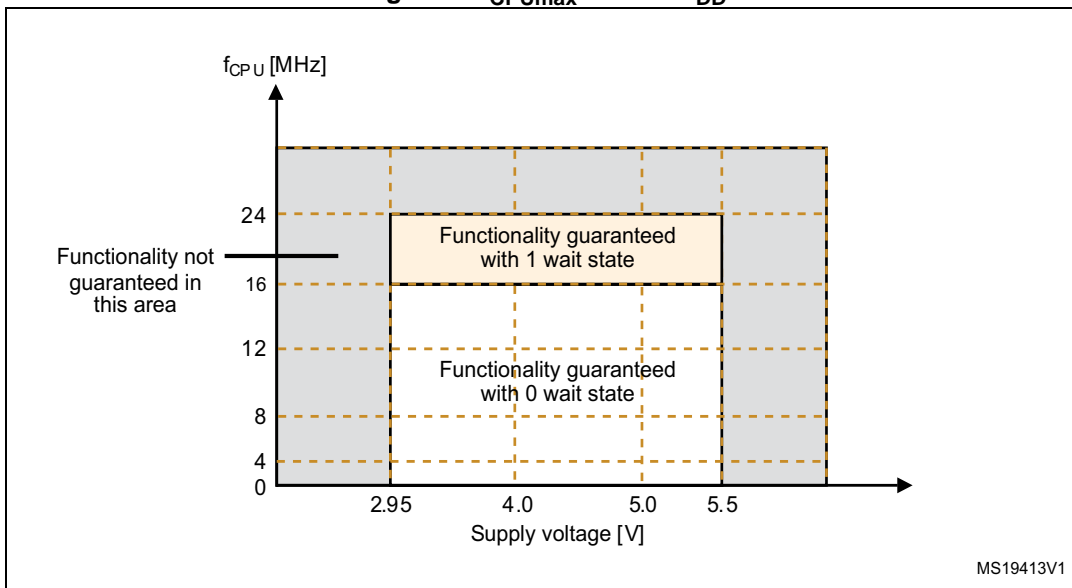

Table 18. Operating conditions at power-up/power-down

Symbol	Parameter	Conditions	Min	Typ	Max	Unit
t_{VDD}	V_{DD} rise time rate	-	2 ⁽¹⁾	-	∞	$\mu\text{s/V}$
	V_{DD} fall time rate	-	2 ⁽¹⁾	-	∞	
t_{TEMP}	Reset release delay	V_{DD} rising	-	-	1.7 ⁽¹⁾	ms
V_{IT+}	Power-on reset threshold ⁽²⁾	-	2.65	2.8	2.95	V
V_{IT-}	Brown-out reset threshold	-	2.58	2.73	2.88	V
$V_{HYS(BOR)}$	Brown-out reset hysteresis	-	-	70	-	mV

1. Guaranteed by design, not tested in production.
2. If V_{DD} is below 2.95 V, the code execution is guaranteed above the V_{IT-} and V_{IT+} thresholds. RAM content is kept. The EEPROM programming sequence must not be initiated.

9.3.1 VCAP external capacitor

Stabilization for the main regulator is achieved connecting an external capacitor C_{EXT} to the V_{CAP} pin. C_{EXT} is specified in [Table 17](#). Care should be taken to limit the series inductance to less than 15 nH.

Figure 10. External capacitor C_{EXT}

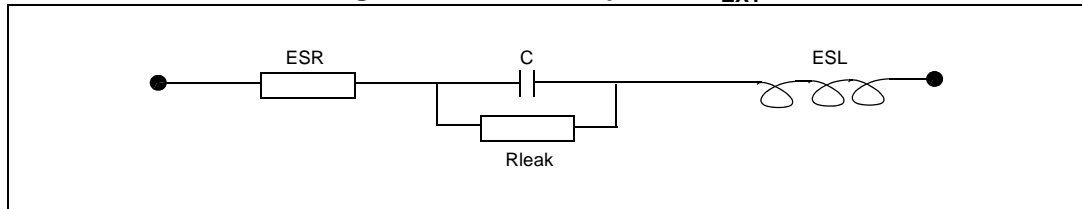

1. Legend: ESR is the equivalent series resistance and ESL is the equivalent inductance.

9.3.2 Supply current characteristics

The current consumption is measured as described in [Figure 6 on page 42](#).

Total current consumption in run mode

The MCU is placed under the following conditions:

- All I/O pins in input mode with a static value at V_{DD} or V_{SS} (no load)
- All peripherals are disabled (clock stopped by Peripheral Clock Gating registers) except if explicitly mentioned.
- When the MCU is clocked at 24 MHz, $T_A \leq 85\text{ °C}$ and the WAITSTATE option bit is set.

Subject to general operating conditions for V_{DD} and T_A .

Table 19. Total current consumption with code execution in run mode at V_{DD} = 5 V

Symbol	Parameter	Conditions	Typ	Max ⁽¹⁾	Unit	
I _{DD(RUN)}	Supply current in run mode, code executed from RAM	f _{CPU} = f _{MASTER} = 16 MHz	HSE crystal osc. (16 MHz)	3.2	-	mA
			HSE user ext. clock (16 MHz)	2.6	3.2	
			HSI RC osc. (16 MHz)	2.5	3.2	
		f _{CPU} = f _{MASTER} /128 = 125 kHz	HSE user ext. clock (16 MHz)	1.6	2.2	
			HSI RC osc. (16 MHz)	1.3	2.0	
		f _{CPU} = f _{MASTER} /128 = 15.625 kHz	HSI RC osc. (16 MHz/8)	0.75	-	
	f _{CPU} = f _{MASTER} = 128 kHz	LSI RC osc. (128 kHz)	0.55	-		
	Supply current in run mode, code executed from Flash	f _{CPU} = f _{MASTER} = 16 MHz	HSE crystal osc. (16 MHz)	7.7	-	
			HSE user ext. clock (16 MHz)	7.0	8.0	
			HSI RC osc.(16 MHz)	7.0	8.0	
		f _{CPU} = f _{MASTER} = 2 MHz	HSI RC osc. (16 MHz/8) ⁽²⁾	1.5	-	
		f _{CPU} = f _{MASTER} /128 = 125 kHz	HSI RC osc. (16 MHz)	1.35	2.0	
		f _{CPU} = f _{MASTER} /128 = 15.625 kHz	HSI RC osc. (16 MHz/8)	0.75	-	
		f _{CPU} = f _{MASTER} = 128 kHz	LSI RC osc. (128 kHz)	0.6	-	

1. Data based on characterization results, not tested in production.
2. Default clock configuration measured with all peripherals off.

Table 20. Total current consumption with code execution in run mode at $V_{DD} = 3.3\text{ V}$

Symbol	Parameter	Conditions	Typ	Max ⁽¹⁾	Unit	
$I_{DD(RUN)}$	Supply current in run mode, code executed from RAM	$f_{CPU} = f_{MASTER} = 16\text{ MHz}$	HSE crystal osc. (16 MHz)	2.8	-	mA
			HSE user ext. clock (16 MHz)	2.6	3.2	
			HSI RC osc. (16 MHz)	2.5	3.2	
		$f_{CPU} = f_{MASTER}/128 = 125\text{ kHz}$	HSE user ext. clock (16 MHz)	1.6	2.2	
			HSI RC osc. (16 MHz)	1.3	2.0	
		$f_{CPU} = f_{MASTER}/128 = 15.625\text{ kHz}$	HSI RC osc. (16MHz/8)	0.75	-	
	$f_{CPU} = f_{MASTER} = 128\text{ kHz}$	LSI RC osc. (128 kHz)	0.55	-		
	Supply current in run mode, code executed from Flash	$f_{CPU} = f_{MASTER} = 16\text{ MHz}$	HSE crystal osc. (16 MHz)	7.3	-	
			HSE user ext. clock (16 MHz)	7.0	8.0	
			HSI RC osc. (16 MHz)	7.0	8.0	
		$f_{CPU} = f_{MASTER} = 2\text{ MHz}$	HSI RC osc. (16 MHz/8) ⁽²⁾	1.5	-	
		$f_{CPU} = f_{MASTER}/128 = 125\text{ kHz}$	HSI RC osc. (16 MHz)	1.35	2.0	
		$f_{CPU} = f_{MASTER}/128 = 15.625\text{ kHz}$	HSI RC osc. (16 MHz/8)	0.75	-	
	$f_{CPU} = f_{MASTER} = 128\text{ kHz}$	LSI RC osc. (128 kHz)	0.6	-		

1. Data based on characterization results, not tested in production.
2. Default clock configuration.

Total current consumption in wait mode

Table 21. Total current consumption in wait mode at V_{DD} = 5 V

Symbol	Parameter	Conditions	Typ	Max ⁽¹⁾	Unit	
I _{DD(WFI)}	Supply current in wait mode	f _{CPU} = f _{MASTER} = 16 MHz	HSE crystal osc. (16 MHz)	2.15	-	mA
			HSE user ext. clock (16 MHz)	1.55	2.0	
			HSI RC osc. (16 MHz)	1.5	1.9	
		f _{CPU} = f _{MASTER} /128 = 125 kHz	HSI RC osc. (16 MHz)	1.3	-	
		f _{CPU} = f _{MASTER} /128 = 15.625 kHz	HSI RC osc. (16 MHz/8) ⁽²⁾	0.7	-	
		f _{CPU} = f _{MASTER} = 128 kHz	LSI RC osc. (128 kHz)	0.5	-	

1. Data based on characterization results, not tested in production.
2. Default clock configuration measured with all peripherals off.

Table 22. Total current consumption in wait mode at V_{DD} = 3.3 V

Symbol	Parameter	Conditions	Typ	Max ⁽¹⁾	Unit	
I _{DD(WFI)}	Supply current in wait mode	f _{CPU} = f _{MASTER} = 16 MHz	HSE crystal osc. (16 MHz)	1.75	-	mA
			HSE user ext. clock (16 MHz)	1.55	2.0	
			HSI RC osc. (16 MHz)	1.5	1.9	
		f _{CPU} = f _{MASTER} /128 = 125 kHz	HSI RC osc. (16 MHz)	1.3	-	
		f _{CPU} = f _{MASTER} /128 = 15.625 kHz	HSI RC osc. (16 MHz/8) ⁽²⁾	0.7	-	
		f _{CPU} = f _{MASTER} /128 = 15.625 kHz	LSI RC osc. (128 kHz)	0.5	-	

1. Data based on characterization results, not tested in production.
2. Default clock configuration measured with all peripherals off.

Total current consumption in active halt mode

Table 23. Total current consumption in active halt mode at V_{DD} = 5 V, T_A -40 to 85° C

Symbol	Parameter	Conditions			Typ	Max ⁽¹⁾	Unit
		Main voltage regulator (MVR) ⁽²⁾	Flash mode ⁽³⁾	Clock source			
I _{DD(AH)}	Supply current in active halt mode	On	Operating mode	HSE crystal oscillator (16 MHz)	1080	-	μA
				LSI RC oscillator (128 kHz)	200	320	
			Power-down mode	HSE crystal oscillator (16 MHz)	1030	-	
				LSI RC oscillator (128 kHz)	140	270	
		Off	Operating mode	LSI RC oscillator (128 kHz)	68	120	
			Power-down mode		12	60	

1. Data based on characterization results, not tested in production.
2. Configured by the REGAH bit in the CLK_ICKR register.
3. Configured by the AHALT bit in the FLASH_CR1 register.

Table 24. Total current consumption in active halt mode at V_{DD} = 3.3 V

Symbol	Parameter	Conditions			Typ	Max at 85° C ⁽¹⁾	Unit
		Main voltage regulator (MVR) ⁽²⁾	Flash mode ⁽³⁾	Clock source			
I _{DD(AH)}	Supply current in active halt mode	On	Operating mode	HSE crystal osc. (16 MHz)	680	-	μA
				LSI RC osc. (128 kHz)	200	320	
			Power-down mode	HSE crystal osc. (16 MHz)	630	-	
				LSI RC osc. (128 kHz)	140	270	
		Off	Operating mode	LSI RC osc. (128 kHz)	66	120	
			Power-down mode		10	60	

1. Data based on characterization results, not tested in production.
2. Configured by the REGAH bit in the CLK_ICKR register.
3. Configured by the AHALT bit in the FLASH_CR1 register.

Total current consumption in halt mode

Table 25. Total current consumption in halt mode at $V_{DD} = 5\text{ V}$, $T_A -40\text{ to }85^\circ\text{ C}$

Symbol	Parameter	Conditions	Typ	Max	Unit
$I_{DD(H)}$	Supply current in halt mode	Flash in operating mode, HSI clock after wakeup	62	90	μA
		Flash in power-down mode, HSI clock after wakeup	6.5	25	

Table 26. Total current consumption in halt mode at $V_{DD} = 3.3\text{ V}$

Symbol	Parameter	Conditions	Typ	Max at $85^\circ\text{ C}^{(1)}$	Unit
$I_{DD(H)}$	Supply current in halt mode	Flash in operating mode, HSI clock after wakeup	60	90	μA
		Flash in power-down mode, HSI clock after wakeup	4.5	20	

1. Data based on characterization results, not tested in production.

Low-power mode wakeup times

Table 27. Wakeup times

Symbol	Parameter	Conditions	Typ	Max ⁽¹⁾	Unit	
$t_{WU(WFI)}$	Wakeup time from wait mode to run mode ⁽³⁾	-	-	⁽²⁾	μs	
		$f_{CPU} = f_{MASTER} = 16\text{ MHz}$.	0.56	-		
$t_{WU(AH)}$	Wakeup time active halt mode to run mode. ⁽³⁾	MVR voltage regulator on ⁽⁴⁾	Flash in operating mode ⁽⁵⁾	HSI (after wakeup)	1 ⁽⁶⁾	2 ⁽⁶⁾
			Flash in power-down mode ⁽⁵⁾		3 ⁽⁶⁾	-
		MVR voltage regulator off ⁽⁴⁾	Flash in operating mode ⁽⁵⁾		48 ⁽⁶⁾	-
			Flash in power-down mode ⁽⁵⁾		50 ⁽⁶⁾	-
$t_{WU(H)}$	Wakeup time from halt mode to run mode ⁽³⁾	Flash in operating mode ⁽⁵⁾	52	-		
		Flash in power-down mode ⁽⁵⁾	54	-		

1. Data guaranteed by design, not tested in production.
2. $t_{WU(WFI)} = 2 \times 1/f_{master} + 7 \times 1/f_{CPU}$
3. Measured from interrupt event to interrupt vector fetch.
4. Configured by the REGAH bit in the CLK_ICKR register.
5. Configured by the AHALT bit in the FLASH_CR1 register.
6. Plus 1 LSI clock depending on synchronization.

Total current consumption and timing in forced reset state

Table 28. Total current consumption and timing in forced reset state

Symbol	Parameter	Conditions	Typ	Max ⁽¹⁾	Unit
I _{DD(R)}	Supply current in reset state ⁽²⁾	V _{DD} = 5 V	500	-	μA
		V _{DD} = 3.3 V	400	-	
t _{RESETBL}	Reset release to bootloader vector fetch	-	-	150	μs

1. Data guaranteed by design, not tested in production.
2. Characterized with all I/Os tied to V_{SS}.

Current consumption of on-chip peripherals

Subject to general operating conditions for V_{DD} and T_A.

HSI internal RC/f_{CPU} = f_{MASTER} = 16 MHz.

Table 29. Peripheral current consumption

Symbol	Parameter	Typ.	Unit
I _{DD(TIM1)}	TIM1 supply current ⁽¹⁾	230	μA
I _{DD(TIM2)}	TIM2 supply current ⁽¹⁾	115	
I _{DD(TIM3)}	TIM3 timer supply current ⁽¹⁾	90	
I _{DD(TIM4)}	TIM4 timer supply current ⁽¹⁾	30	
I _{DD(UART2)}	UART2 supply current ⁽²⁾	110	
I _{DD(SPI)}	SPI supply current ⁽²⁾	45	
I _{DD(I2C)}	I ² C supply current ⁽²⁾	65	
I _{DD(ADC1)}	ADC1 supply current when converting ⁽³⁾	955	

1. Data based on a differential I_{DD} measurement between reset configuration and timer counter running at 16 MHz. No IC/OC programmed (no I/O pads toggling). Not tested in production.
2. Data based on a differential I_{DD} measurement between the on-chip peripheral when kept under reset and not clocked and the on-chip peripheral when clocked and not kept under reset. No I/O pads toggling. Not tested in production.
3. Data based on a differential I_{DD} measurement between reset configuration and continuous A/D conversions. Not tested in production.

Current consumption curves

Figure 15 to Figure 16 show typical current consumption measured with code executing in RAM.

Figure 11. Typ. $I_{DD(RUN)}$ vs V_{DD} , HSE user external clock, $f_{CPU} = 16$ MHz

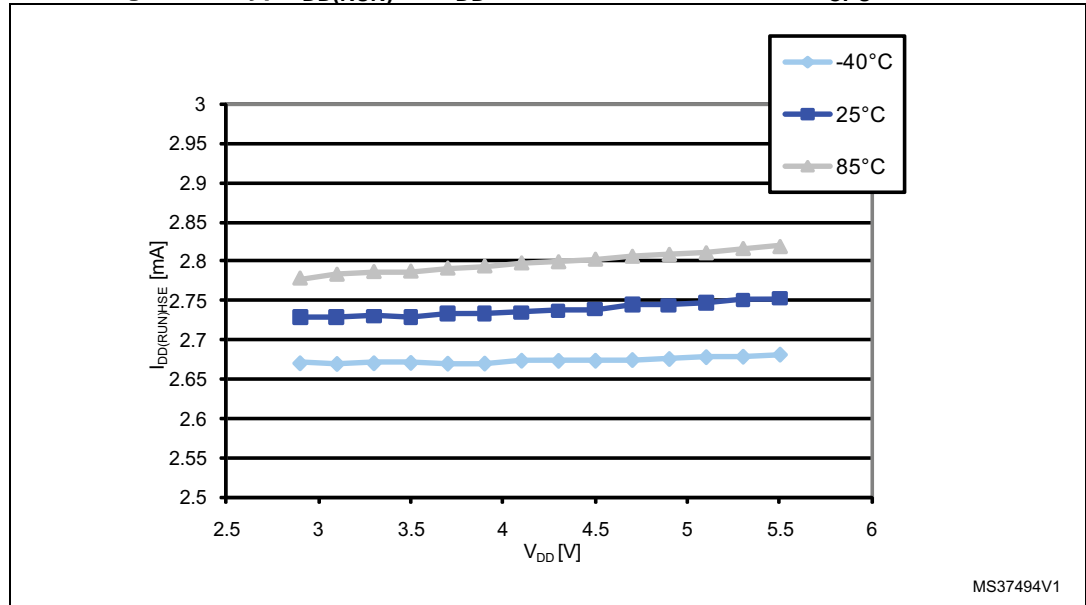

Figure 12. Typ. $I_{DD(RUN)}$ vs V_{DD} , HSE user external clock, $V_{DD} = 5$ V

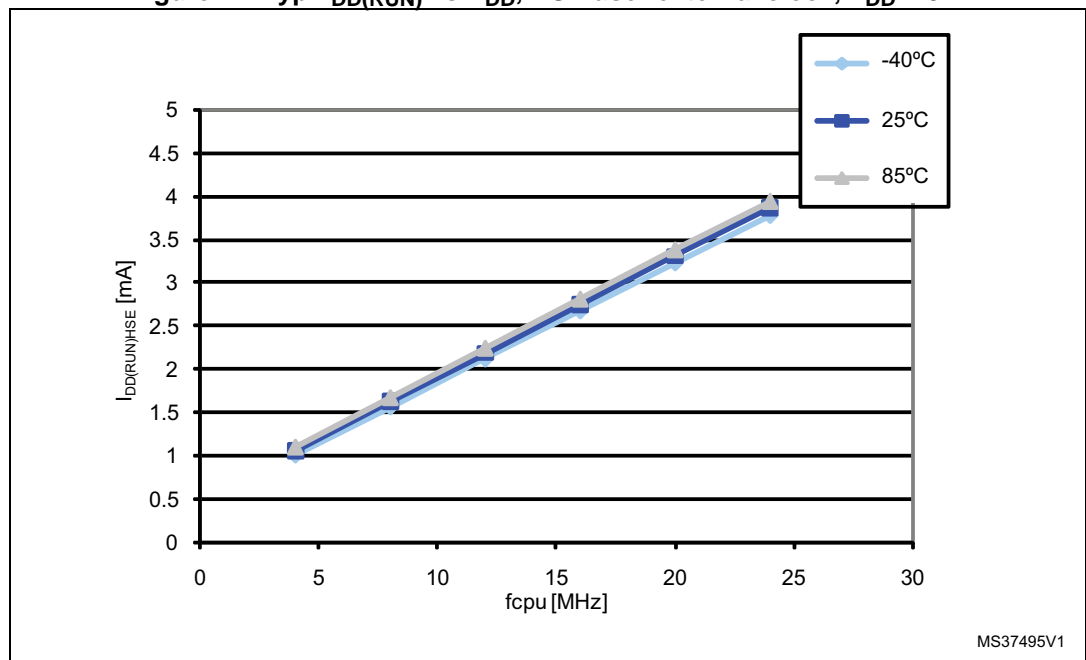

Figure 13. Typ. $I_{DD(WFI)}$ vs V_{DD} , HSE user external clock, $f_{CPU} = 16$ MHz

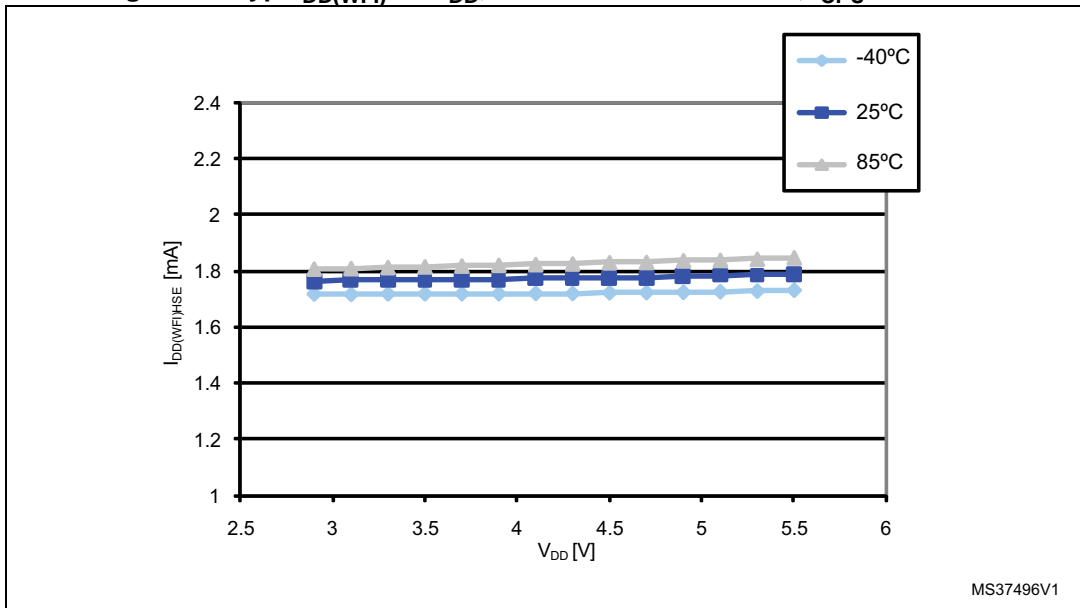

Figure 14. Typ. $I_{DD(WFI)}$ vs V_{DD} , HSE user external clock, $V_{DD} = 5$ V

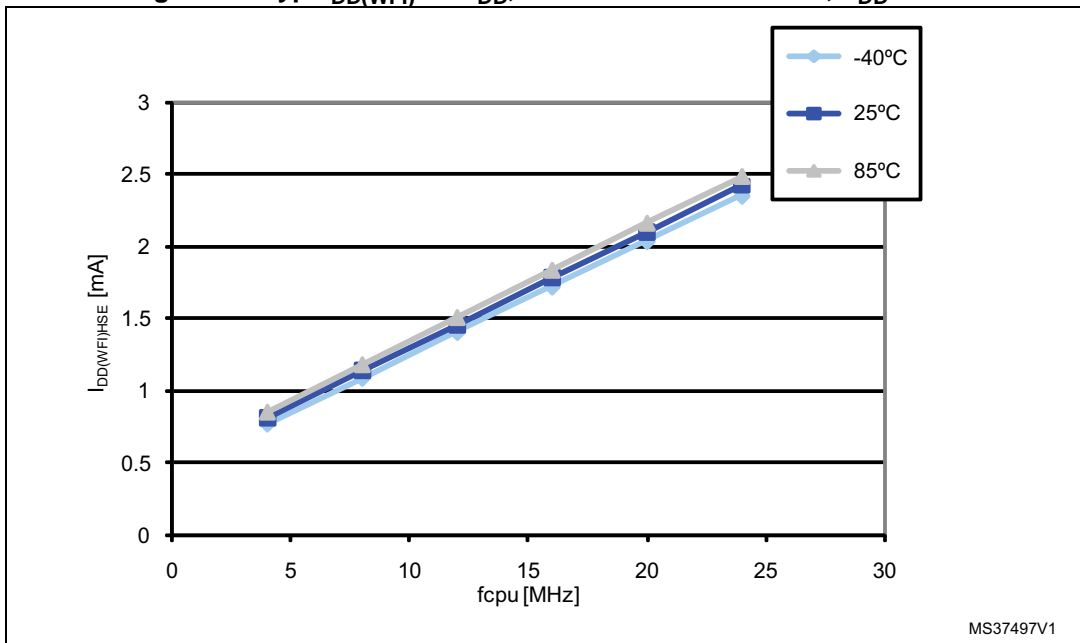

Figure 15. Typ. $I_{DD(RUN)}$ vs V_{DD} , HSI RC osc, $f_{CPU} = 16$ MHz

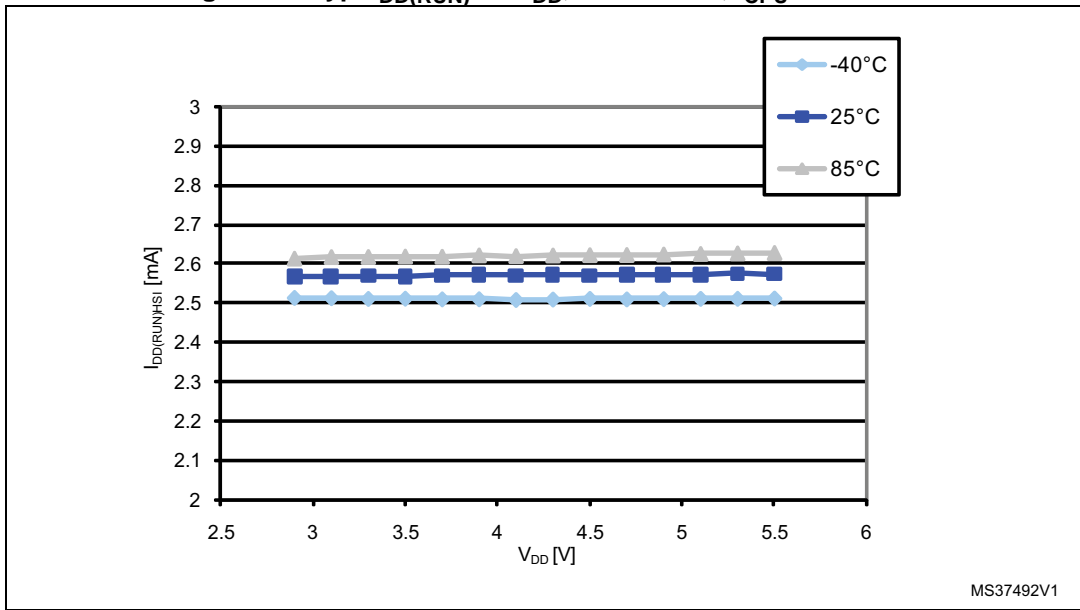
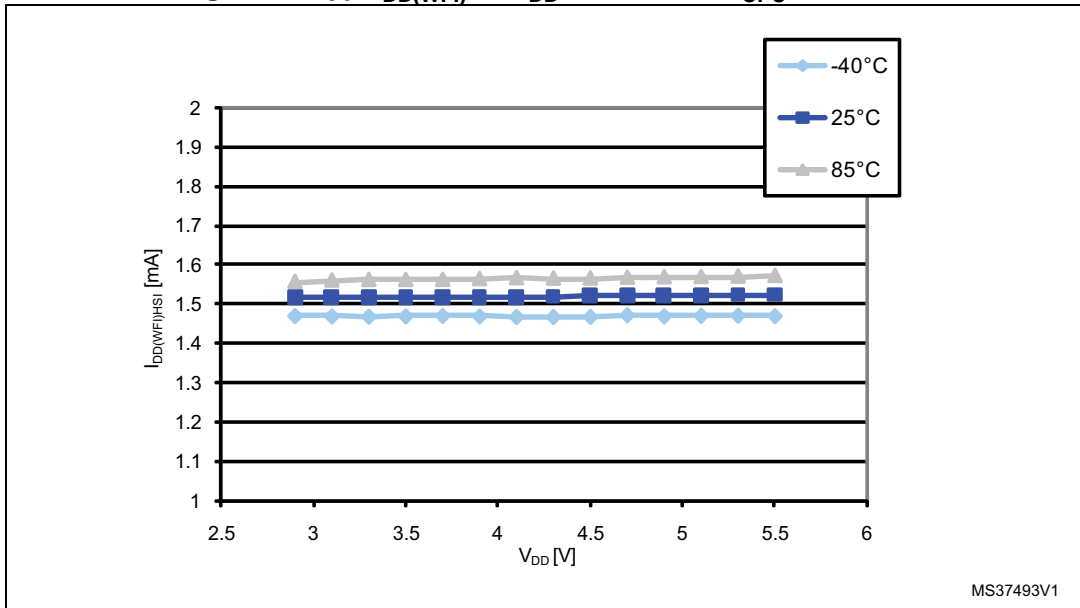

Figure 16. Typ. $I_{DD(WFI)}$ vs V_{DD} , HSI RC osc, $f_{CPU} = 16$ MHz



9.3.3 External clock sources and timing characteristics

HSE user external clock

Subject to general operating conditions for V_{DD} and T_A .

Table 30. HSE user external clock characteristics

Symbol	Parameter	Conditions	Min	Typ	Max	Unit
f_{HSE_ext}	User external clock source frequency		0	-	16	MHz
$V_{HSEH}^{(1)}$	OSCIN input pin high level voltage	-	$0.7 \times V_{DD}$	-	$V_{DD} + 0.3 \text{ V}$	V
$V_{HSEL}^{(1)}$	OSCIN input pin low level voltage		V_{SS}	-	$0.3 \times V_{DD}$	
I_{LEAK_HSE}	OSCIN input leakage current	$V_{SS} < V_{IN} < V_{DD}$	-1	-	1	μA

1. Data based on characterization results, not tested in production.

Figure 17. HSE external clock source

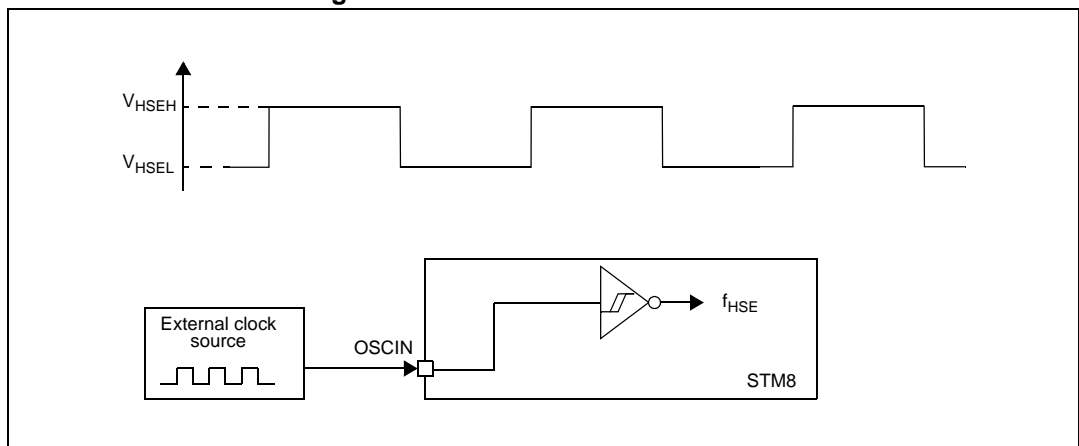

HSE crystal/ceramic resonator oscillator

The HSE clock can be supplied with a 1 to 24 MHz crystal/ceramic resonator oscillator. All the information given in this paragraph is based on characterization results with specified typical external components. In the application, the resonator and the load capacitors have to be placed as close as possible to the oscillator pins in order to minimize output distortion and start-up stabilization time. Refer to the crystal resonator manufacturer for more details (frequency, package, accuracy...).

Table 31. HSE oscillator characteristics

Symbol	Parameter	Conditions	Min	Typ	Max	Unit
f _{HSE}	External high speed oscillator frequency	-	1	-	16	MHz
R _F	Feedback resistor	-	-	220	-	kΩ
C ⁽¹⁾	Recommended load capacitance ⁽²⁾	-	-	-	20	pF
I _{DD(HSE)}	HSE oscillator power consumption	C = 20 pF, f _{OSC} = 16 MHz	-	-	6 (startup) 1.6 (stabilized) ⁽³⁾	mA
		C = 10 pF, f _{OSC} = 16 MHz	-	-	6 (startup) 1.2 (stabilized) ⁽³⁾	
g _m	Oscillator transconductance	-	5	-	-	mA/V
t _{SU(HSE)} ⁽⁴⁾	Startup time	V _{DD} is stabilized	-	1	-	ms

1. C is approximately equivalent to 2 x crystal Load.
2. The oscillator selection can be optimized in terms of supply current using a high quality resonator with small R_m value. Refer to crystal manufacturer for more details
3. Data based on characterization results, not tested in production.
4. t_{SU(HSE)} is the start-up time measured from the moment it is enabled (by software) to a stabilized 24 MHz oscillation is reached. This value is measured for a standard crystal resonator and it can vary significantly with the crystal manufacturer.

Figure 18. HSE oscillator circuit diagram

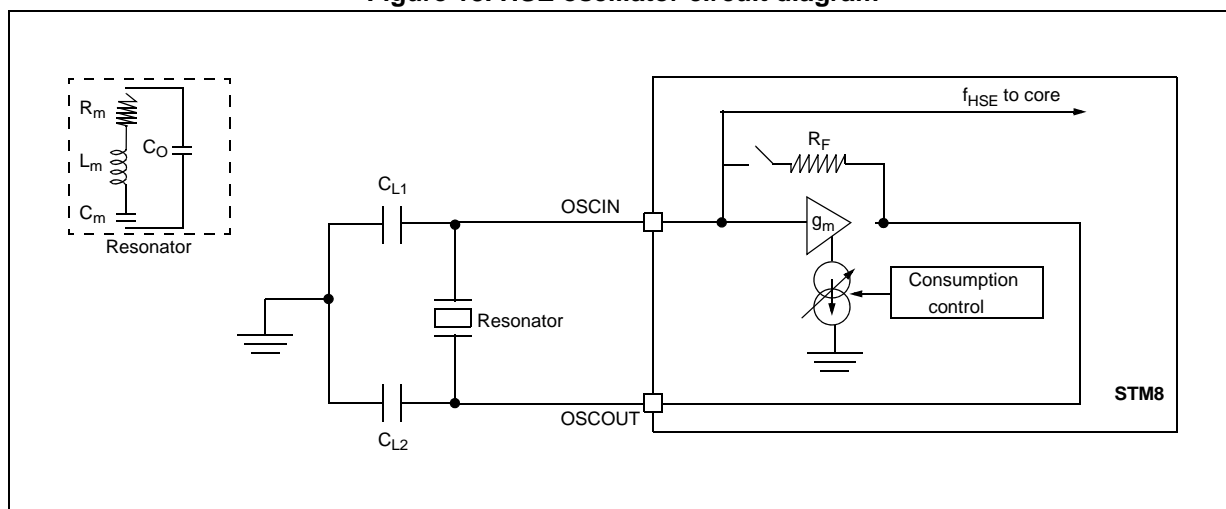

HSE oscillator critical g_m formula

$$g_{m\text{crit}} = (2 \times \pi \times f_{\text{HSE}})^2 \times R_m(2C_o + C)^2$$

- R_m: Notional resistance (see crystal specification)
- L_m: Notional inductance (see crystal specification)
- C_m: Notional capacitance (see crystal specification)
- Co: Shunt capacitance (see crystal specification)
- C_{L1}=C_{L2}=C: Grounded external capacitance
- g_m >> g_mcrit

9.3.4 Internal clock sources and timing characteristics

Subject to general operating conditions for V_{DD} and T_A . f_{HSE}

High speed internal RC oscillator (HSI)

Table 32. HSI oscillator characteristics

Symbol	Parameter	Conditions	Min	Typ	Max	Unit
f_{HSI}	Frequency	-	-	16	-	MHz
ACC_{HSI}	Accuracy of HSI oscillator	Trimmed by the CLK_HSITRIMR register for given V_{DD} and T_A conditions ⁽¹⁾	-	-	1.0 ⁽²⁾	%
	Accuracy of HSI oscillator (factory calibrated)	$V_{DD} = 5\text{ V}$, $T_A = 25\text{ °C}$ $V_{DD} = 5\text{ V}$, $-40\text{ °C} \leq T_A \leq 85\text{ °C}$	-5	-	5	
$t_{su(HSI)}$	HSI oscillator wakeup time including calibration	-	-	-	1.0 ⁽²⁾	μs
$I_{DD(HSI)}$	HSI oscillator power consumption	-	-	170	250 ⁽³⁾	μA

1. See the application note.
2. Guaranteed by design, not tested in production.
3. Data based on characterization results, not tested in production

Figure 19. Typical HSI frequency variation vs V_{DD} at 3 temperatures

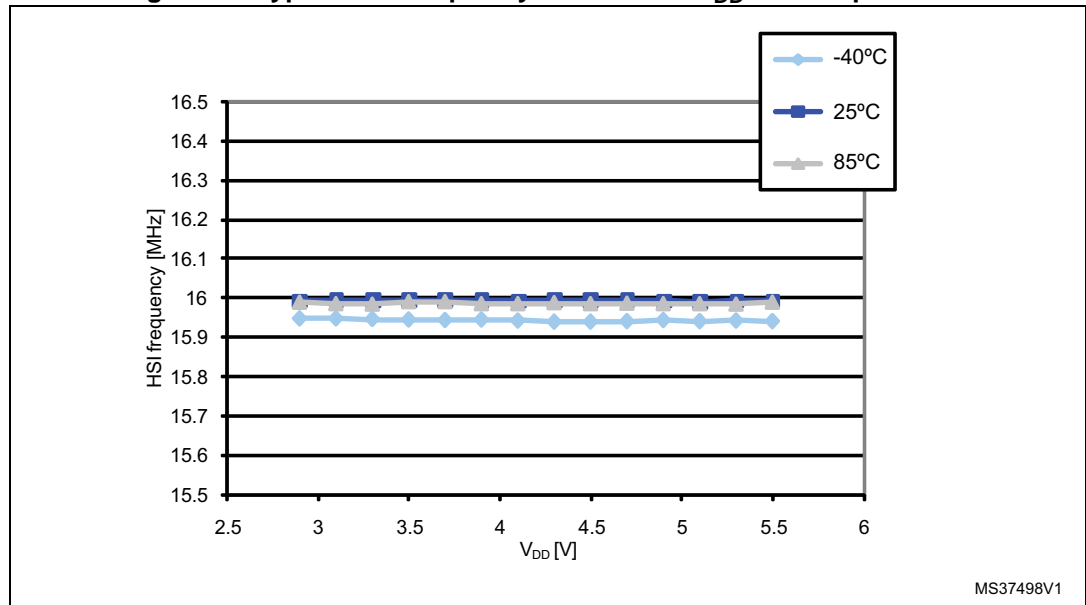

MS37498V1

Low speed internal RC oscillator (LSI)

Subject to general operating conditions for V_{DD} and T_A .

Table 33. LSI oscillator characteristics

Symbol	Parameter	Conditions	Min	Typ	Max	Unit
f_{LSI}	Frequency	-	-	128	-	kHz
$t_{su(LSI)}$	LSI oscillator wakeup time	-	-	-	7 ⁽¹⁾	μs
$I_{DD(LSI)}$	LSI oscillator power consumption	-	-	5	-	μA

1. Guaranteed by design, not tested in production.

Figure 20. Typical LSI frequency variation vs V_{DD} @ 25 °C

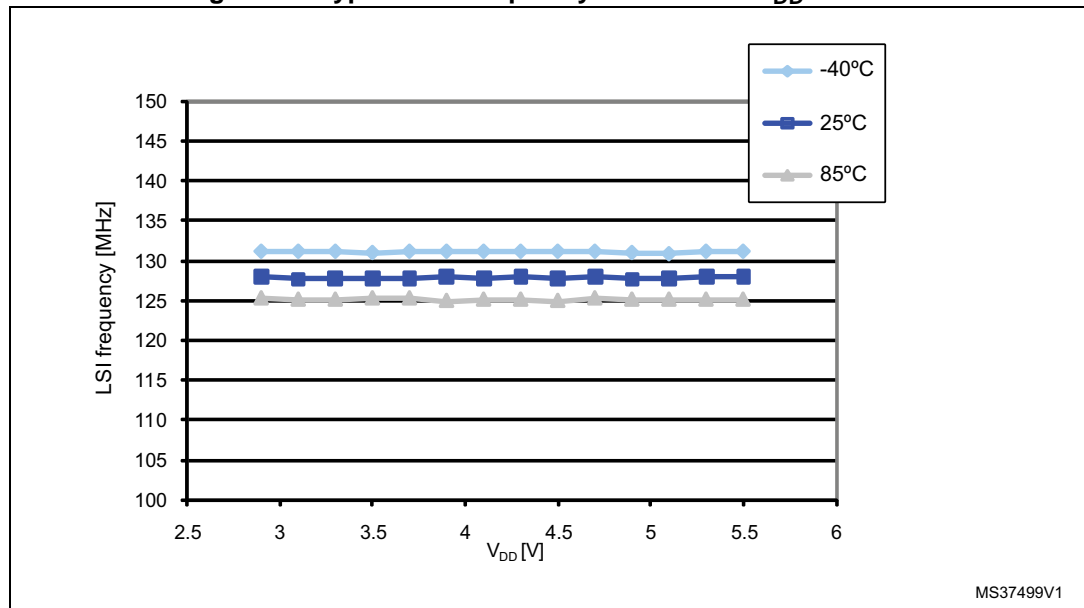

9.3.5 Memory characteristics

RAM and hardware registers

Table 34. RAM and hardware registers

Symbol	Parameter	Conditions	Min	Unit
V_{RM}	Data retention mode ⁽¹⁾	Halt mode (or reset)	V_{IT-max} ⁽²⁾	V

1. Minimum supply voltage without losing data stored in RAM (in halt mode or under reset) or in hardware registers (only in halt mode). Guaranteed by design, not tested in production.

2. Refer to [Table 18 on page 47](#) for the value of V_{IT-max} .

Flash program memory/data EEPROM memory

General conditions: $T_A = -40$ to 85 °C.

Table 35. Flash program memory/data EEPROM memory

Symbol	Parameter	Conditions	Min ⁽¹⁾	Typ	Max	Unit
V_{DD}	Operating voltage (all modes, execution/write/erase)	$f_{CPU} \leq 16$ MHz	2.95	-	5.5	V
t_{prog}	Standard programming time (including erase) for byte/word/block (1 byte/4 bytes/128 bytes)	-	-	6.0	6.6	ms
	Fast programming time for 1 block (128 bytes)	-	-	3.0	3.3	ms
t_{erase}	Erase time for 1 block (128 bytes)	-	-	3.0	3.3	ms
N_{RW}	Erase/write cycles ⁽²⁾ (program memory)	$T_A = 85$ °C	100	-	-	cycles
	Erase/write cycles ⁽²⁾ (data memory)		100 k	-	-	
t_{RET}	Data retention (program memory) after 100 erase/write cycles at $T_A = 85$ °C	$T_{RET} = 55$ °C	20	-	-	years
	Data retention (data memory) after 10 k erase/write cycles at $T_A = 85$ °C		20	-	-	
	Data retention (data memory) after 100 k erase/write cycles at $T_A = 85$ °C	$T_{RET} = 85$ °C	1.0	-	-	
I_{DD}	Supply current (Flash programming or erasing for 1 to 128 bytes)	-	-	2.0	-	mA

1. Data based on characterization results, not tested in production.

2. The physical granularity of the memory is 4 bytes, so cycling is performed on 4 bytes even when a write/erase operation addresses a single byte.

9.3.6 I/O port pin characteristics

General characteristics

Subject to general operating conditions for V_{DD} and T_A unless otherwise specified. All unused pins must be kept at a fixed voltage: using the output mode of the I/O for example or an external pull-up or pull-down resistor.

Table 36. I/O static characteristics

Symbol	Parameter	Conditions	Min	Typ	Max	Unit
V_{IL}	Input low level voltage	$V_{DD} = 5\text{ V}$	-0.3	-	$0.3 \times V_{DD}$	V
V_{IH}	Input high level voltage		$0.7 \times V_{DD}$	-	$V_{DD} + 0.3\text{ V}$	V
V_{hys}	Hysteresis ⁽¹⁾		-	700	-	mV
R_{pu}	Pull-up resistor	$V_{DD} = 5\text{ V}, V_{IN} = V_{SS}$	30	55	80	k Ω
t_R, t_F	Rise and fall time (10% - 90%)	Fast I/Os Load = 50 pF	-	-	$35^{(2)}$	ns
		Standard and high sink I/Os Load = 50 pF	-	-	$125^{(2)}$	ns
I_{lkg}	Input leakage current, analog and digital	$V_{SS} \leq V_{IN} \leq V_{DD}$	-	-	$\pm 1^{(3)}$	μA
$I_{lkg\text{ ana}}$	Analog input leakage current	$V_{SS} \leq V_{IN} \leq V_{DD}$	-	-	$\pm 250^{(3)}$	nA
$I_{lkg(inj)}$	Leakage current in adjacent I/O	Injection current $\pm 4\text{ mA}$	-	-	$\pm 1^{(3)}$	μA

1. Hysteresis voltage between Schmitt trigger switching levels. Based on characterization results, not tested in production.
2. Data guaranteed by design, not tested in production.
3. Data based on characterization results, not tested in production.

Figure 21. Typical V_{IL} and V_{IH} vs V_{DD} @ 3 temperatures

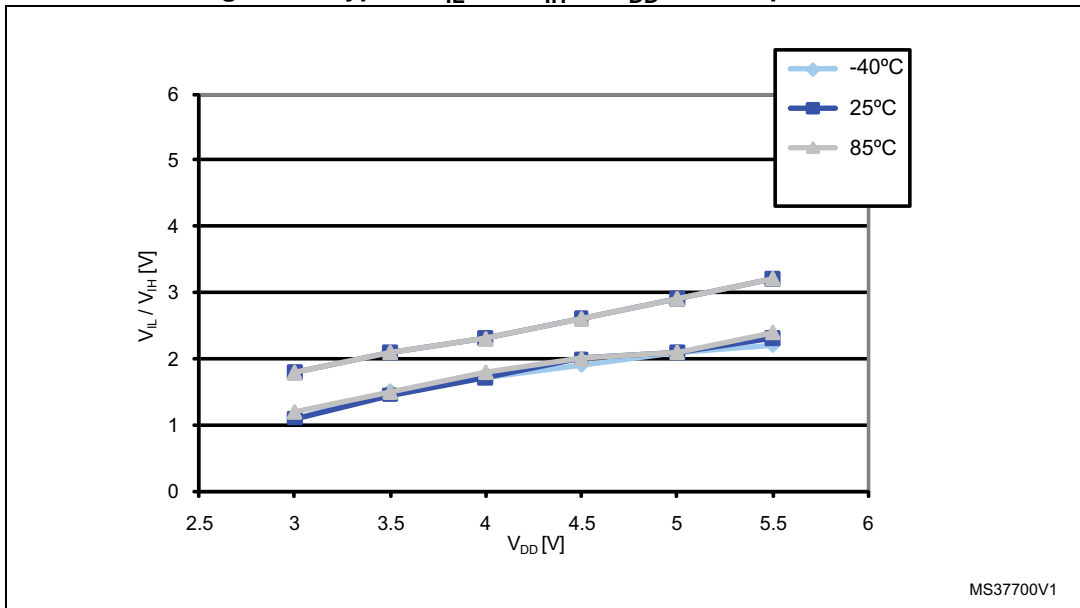

Figure 22. Typical pull-up resistance vs V_{DD} @ 3 temperatures

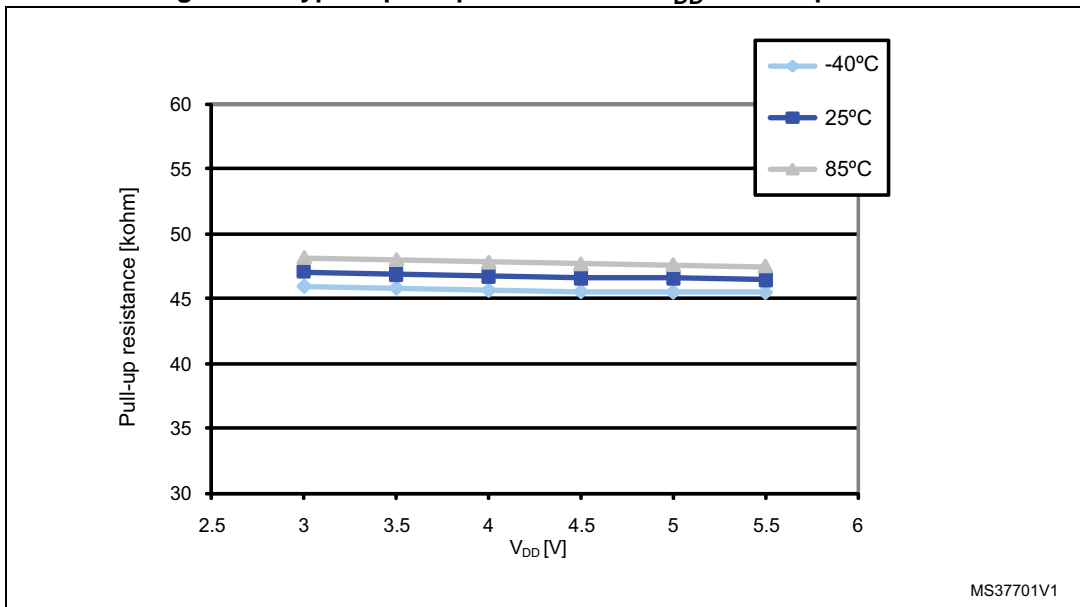
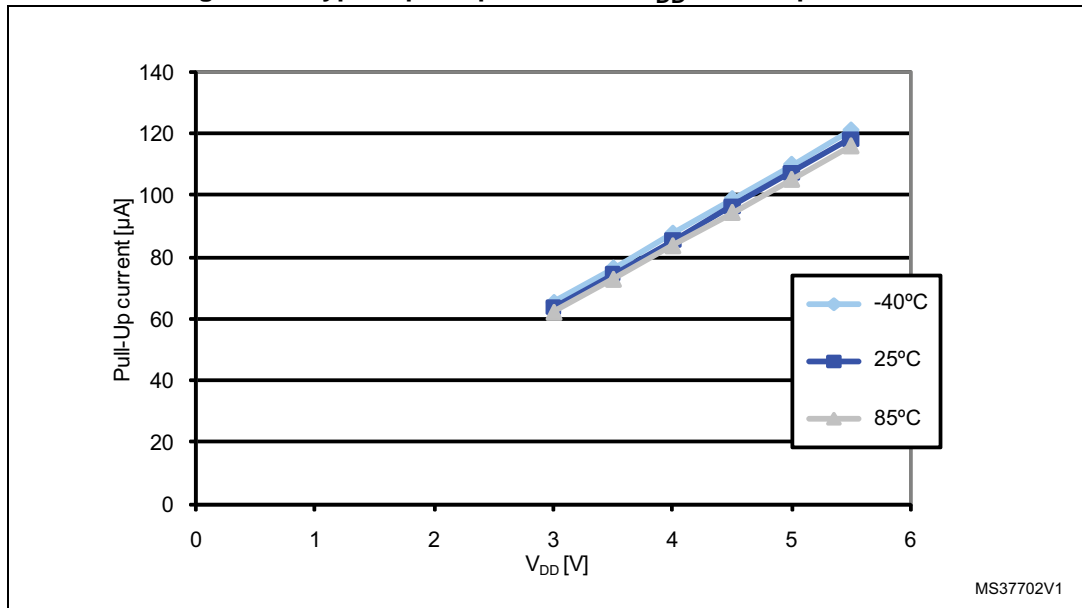

Figure 23. Typical pull-up current vs V_{DD} @ 3 temperatures



1. The pull-up is a pure resistor (slope goes through 0).

Table 37. Output driving current (standard ports)

Symbol	Parameter	Conditions	Min	Max	Unit
V_{OL}	Output low level with 8 pins sunk	$I_{IO} = 10 \text{ mA}$, $V_{DD} = 5 \text{ V}$	-	2	V
	Output low level with 4 pins sunk	$I_{IO} = 4 \text{ mA}$, $V_{DD} = 3.3 \text{ V}$	-	1 ⁽¹⁾	
V_{OH}	Output high level with 8 pins sourced	$I_{IO} = 10 \text{ mA}$, $V_{DD} = 5 \text{ V}$	2.4	-	V
	Output high level with 4 pins sourced	$I_{IO} = 4 \text{ mA}$, $V_{DD} = 3.3 \text{ V}$	2.0 ⁽¹⁾	-	

1. Data based on characterization results, not tested in production

Table 38. Output driving current (true open drain ports)

Symbol	Parameter	Conditions	Max	Unit
V_{OL}	Output low level with 2 pins sunk	$I_{IO} = 10 \text{ mA}$, $V_{DD} = 5 \text{ V}$	1	V
		$I_{IO} = 10 \text{ mA}$, $V_{DD} = 3.3 \text{ V}$	1.5 ⁽¹⁾	
		$I_{IO} = 20 \text{ mA}$, $V_{DD} = 5 \text{ V}$	2 ⁽¹⁾	

1. Data based on characterization results, not tested in production

Table 39. Output driving current (high sink ports)

Symbol	Parameter	Conditions	Min	Max	Unit
V _{OL}	Output low level with 8 pins sunk	I _{IO} = 10 mA, V _{DD} = 5 V	-	0.9	V
	Output low level with 4 pins sunk	I _{IO} = 10 mA, V _{DD} = 3.3 V	-	1.1 ⁽¹⁾	
	Output low level with 4 pins sunk	I _{IO} = 20 mA, V _{DD} = 5 V	-	1.6 ⁽¹⁾	
V _{OH}	Output high level with 8 pins sourced	I _{IO} = 10 mA, V _{DD} = 5 V	3.8	-	
	Output high level with 4 pins sourced	I _{IO} = 10 mA, V _{DD} = 3.3 V	1.9 ⁽¹⁾	-	
	Output high level with 4 pins sourced	I _{IO} = 20 mA, V _{DD} = 5 V	2.9 ⁽¹⁾	-	

1. Data based on characterization results, not tested in production

Typical output level curves

Figure 25 to Figure 32 show typical output level curves measured with output on a single pin.

Figure 24. Typ. V_{OL} @ V_{DD} = 5 V (standard ports)

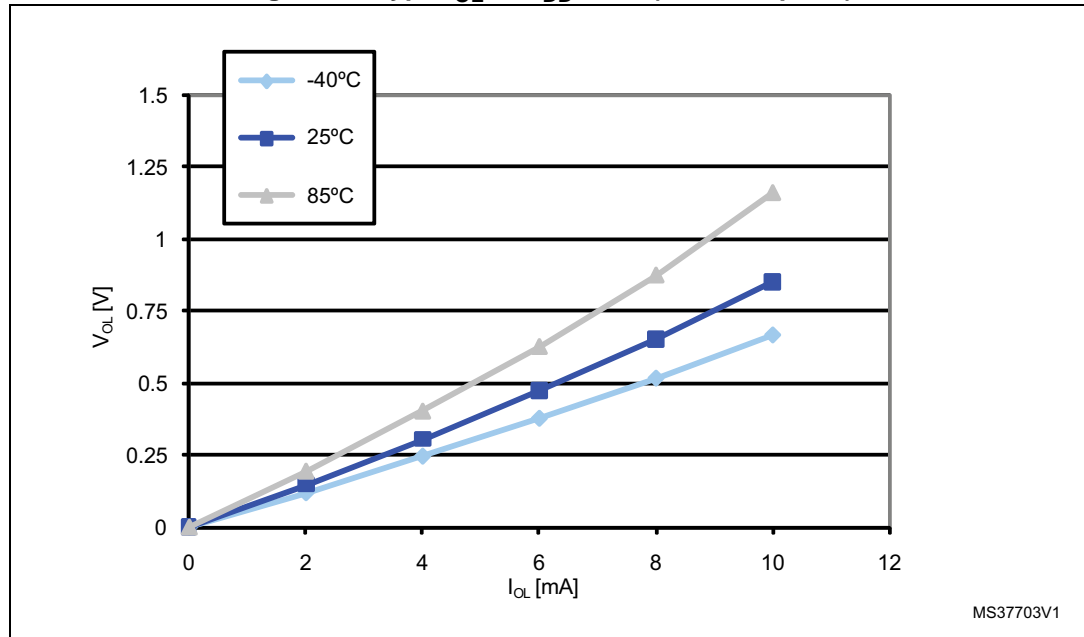

Figure 25. Typ. V_{OL} @ $V_{DD} = 3.3\text{ V}$ (standard ports)

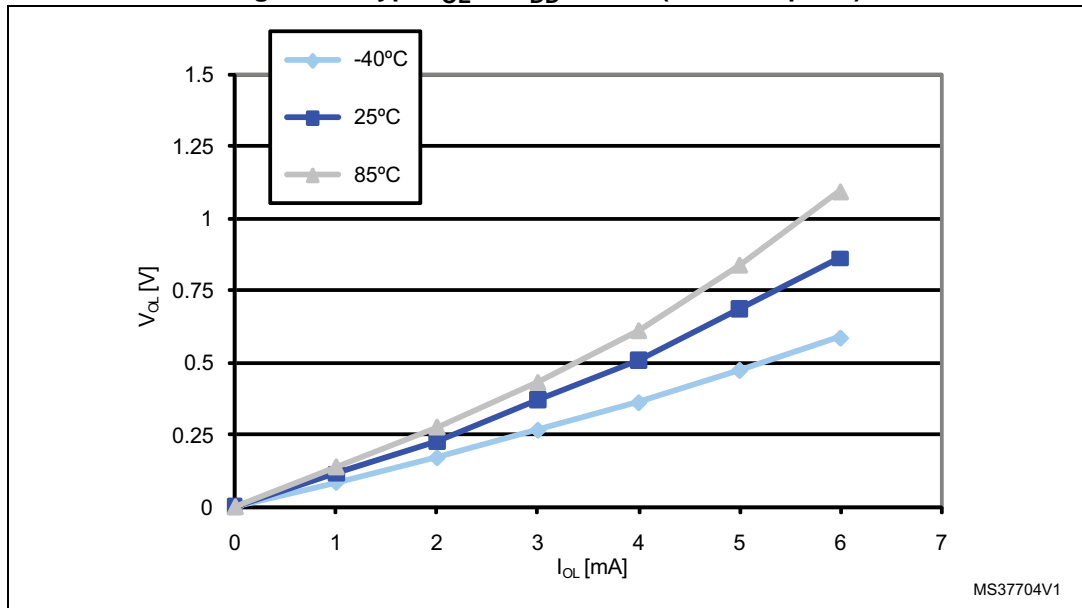

Figure 26. Typ. V_{OL} @ $V_{DD} = 5\text{ V}$ (true open drain ports)

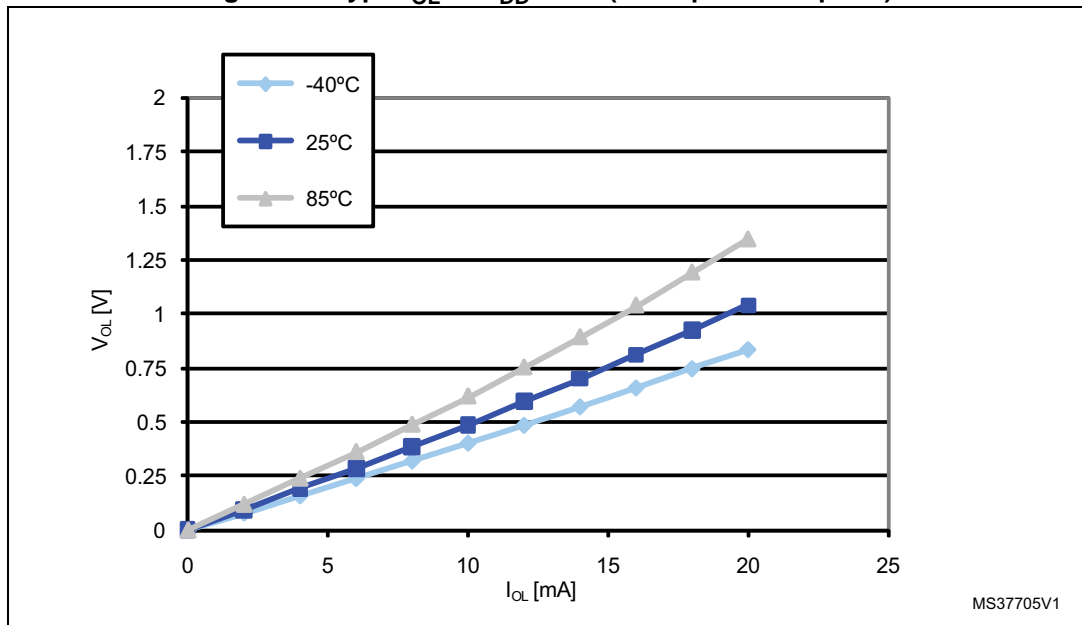

Figure 27. Typ. V_{OL} @ $V_{DD} = 3.3\text{ V}$ (true open drain ports)

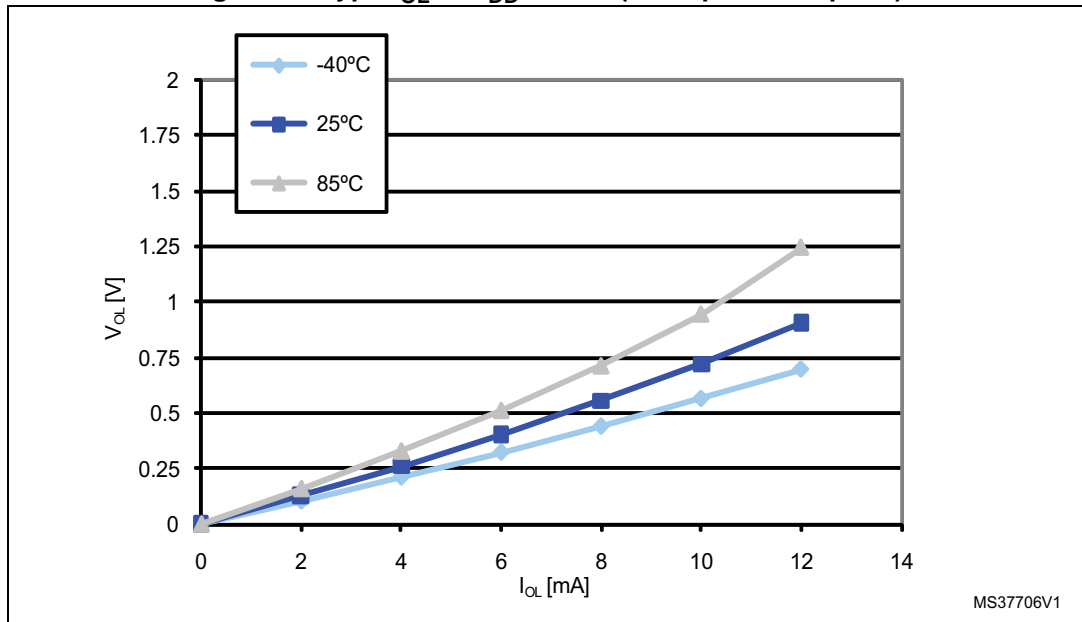

Figure 28. Typ. V_{OL} @ $V_{DD} = 5\text{ V}$ (high sink ports)

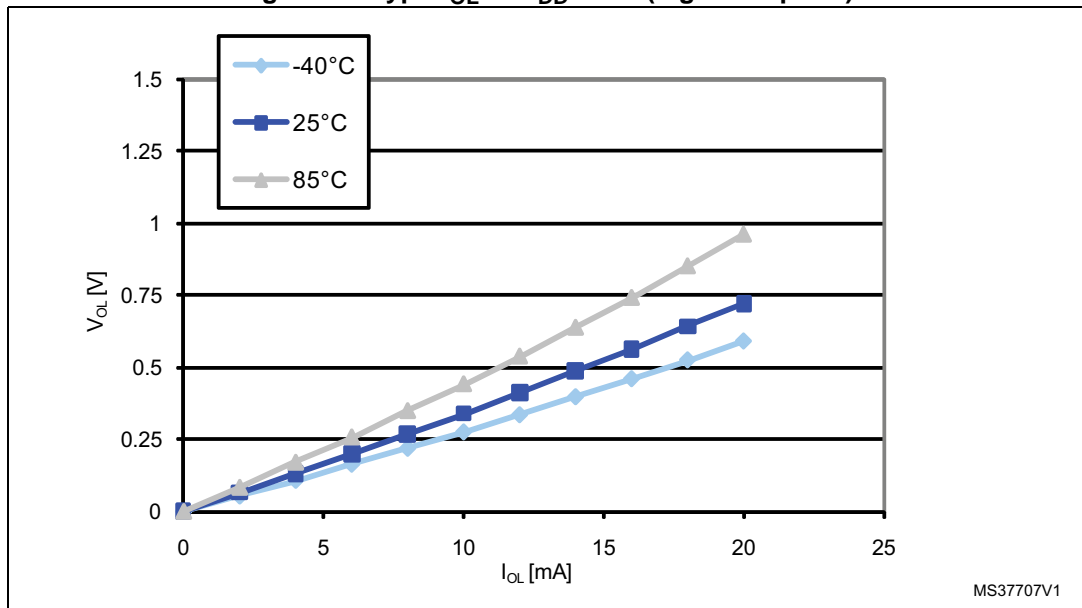

Figure 29. Typ. V_{OL} @ $V_{DD} = 3.3$ V (high sink ports)

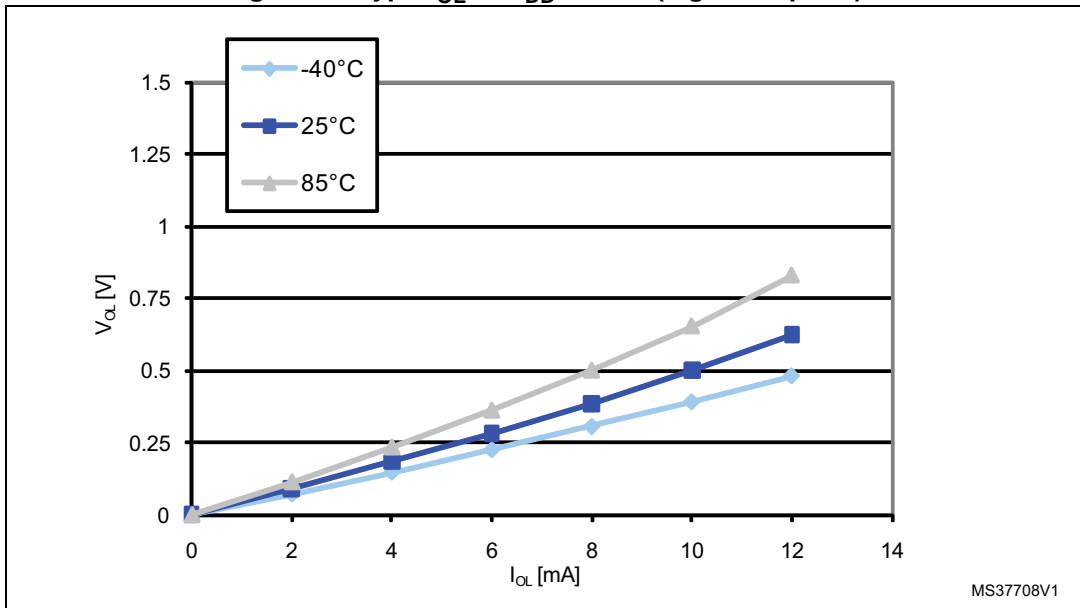

Figure 30. Typ. $V_{DD} - V_{OH}$ @ $V_{DD} = 5$ V (standard ports)

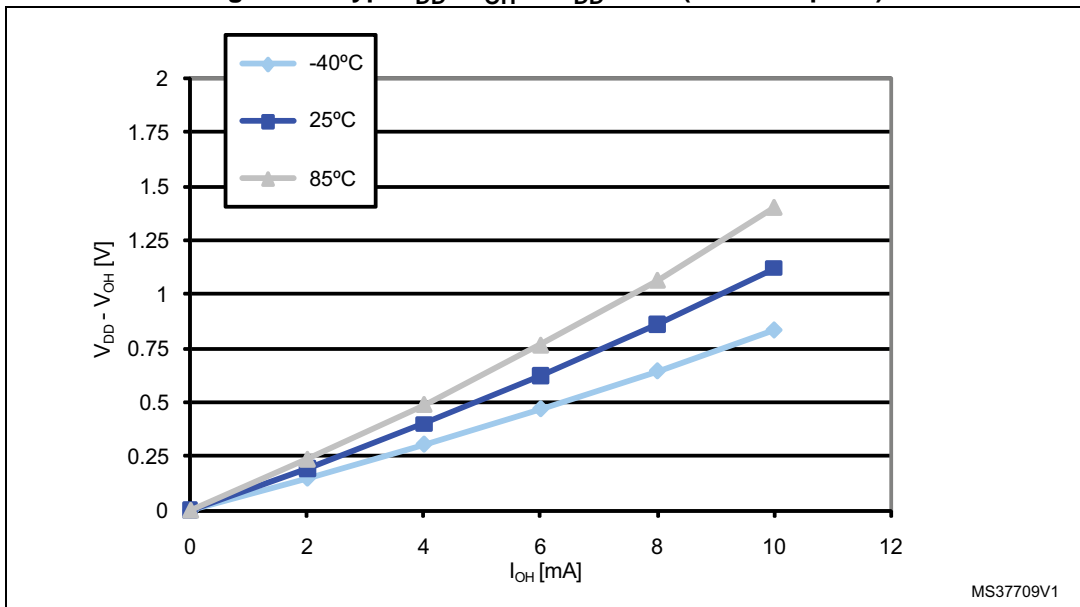

Figure 31. Typ. $V_{DD} - V_{OH}$ @ $V_{DD} = 3.3\text{ V}$ (standard ports)

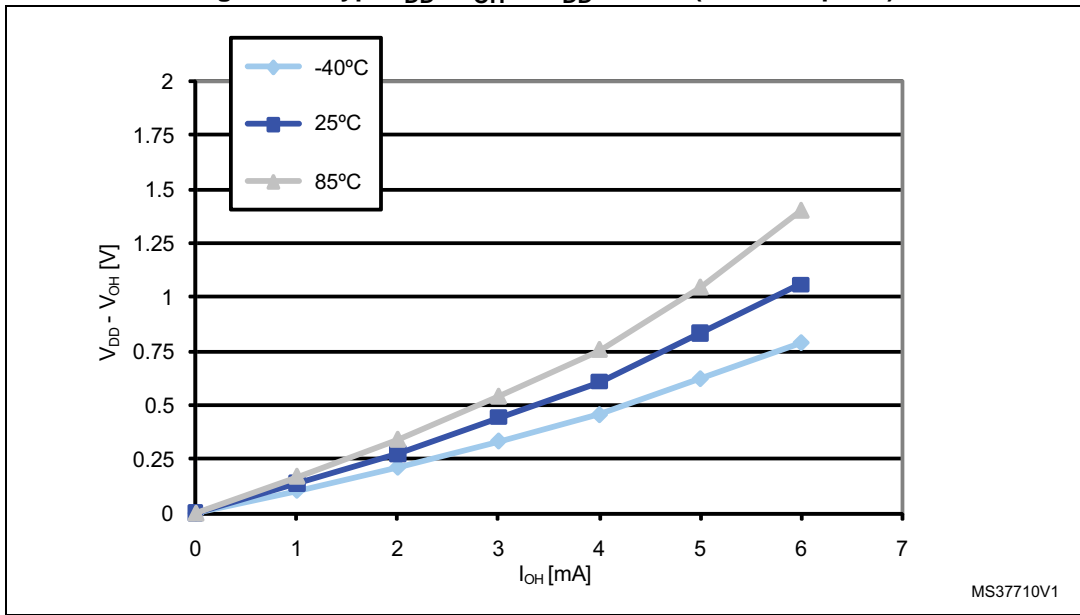

Figure 32. Typ. $V_{DD} - V_{OH}$ @ $V_{DD} = 5\text{ V}$ (high sink ports)

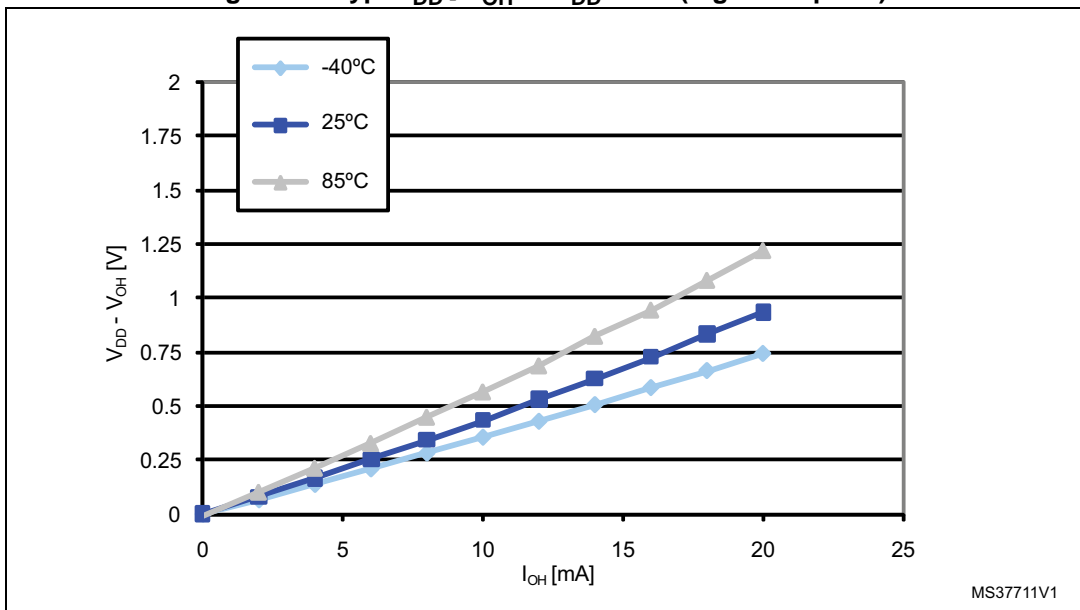
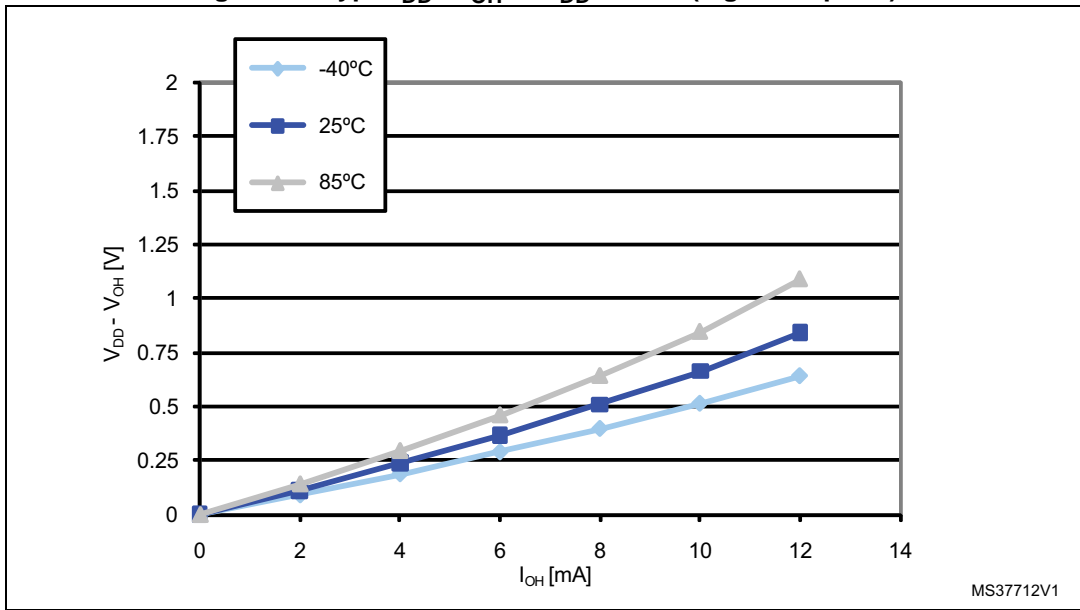

Figure 33. Typ. $V_{DD} - V_{OH}$ @ $V_{DD} = 3.3$ V (high sink ports)



9.3.7 Reset pin characteristics

Subject to general operating conditions for V_{DD} and T_A unless otherwise specified.

Table 40. NRST pin characteristics

Symbol	Parameter	Conditions	Min	Typ ¹⁾	Max	Unit
$V_{IL(NRST)}$	NRST input low level voltage ⁽¹⁾	-	-0.3 V	-	$0.3 \times V_{DD}$	V
$V_{IH(NRST)}$	NRST input high level voltage ⁽¹⁾	-	$0.7 \times V_{DD}$	-	$V_{DD} + 0.3$	
$V_{OL(NRST)}$	NRST output low level voltage ⁽¹⁾	$I_{OL} = 2 \text{ mA}$	-	-	0.5	
$R_{PU(NRST)}$	NRST pull-up resistor ⁽²⁾	-	30	55	80	k Ω
$t_{IFP(NRST)}$	NRST input filtered pulse ⁽³⁾	-	-	-	75	ns
$t_{INFP(NRST)}$	NRST Input not filtered pulse ⁽³⁾	-	500	-	-	ns
$t_{OP(NRST)}$	NRST output pulse ⁽¹⁾	-	15	-	-	μs

1. Data based on characterization results, not tested in production.
2. The R_{PU} pull-up equivalent resistor is based on a resistive transistor
3. Data guaranteed by design, not tested in production.

Figure 34. Typical NRST V_{IL} and V_{IH} vs V_{DD} @ 3 temperatures

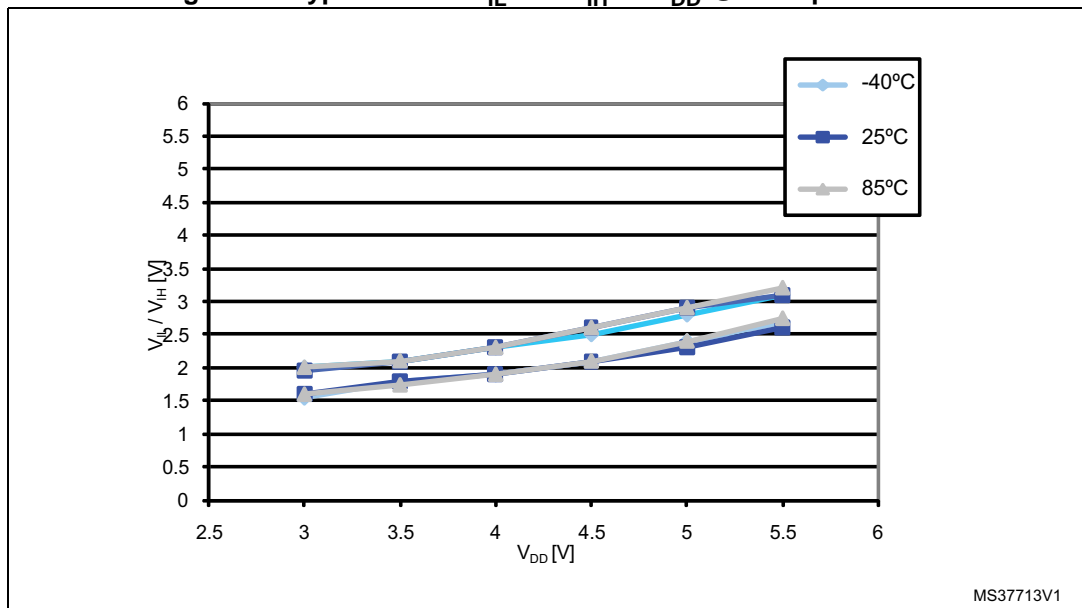

Figure 35. Typical NRST pull-up resistance vs V_{DD} @ 3 temperatures

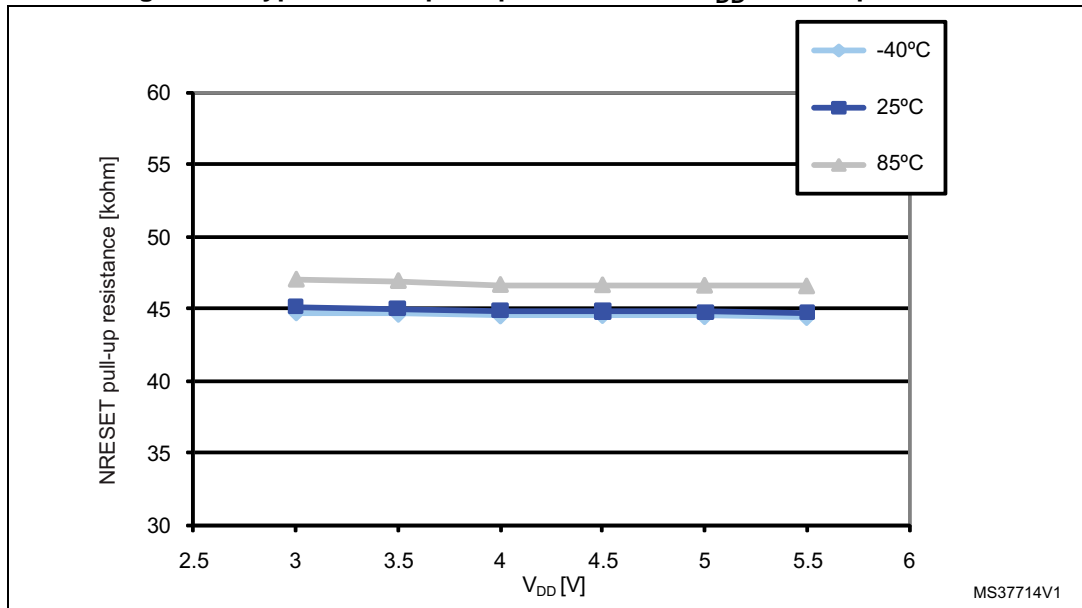
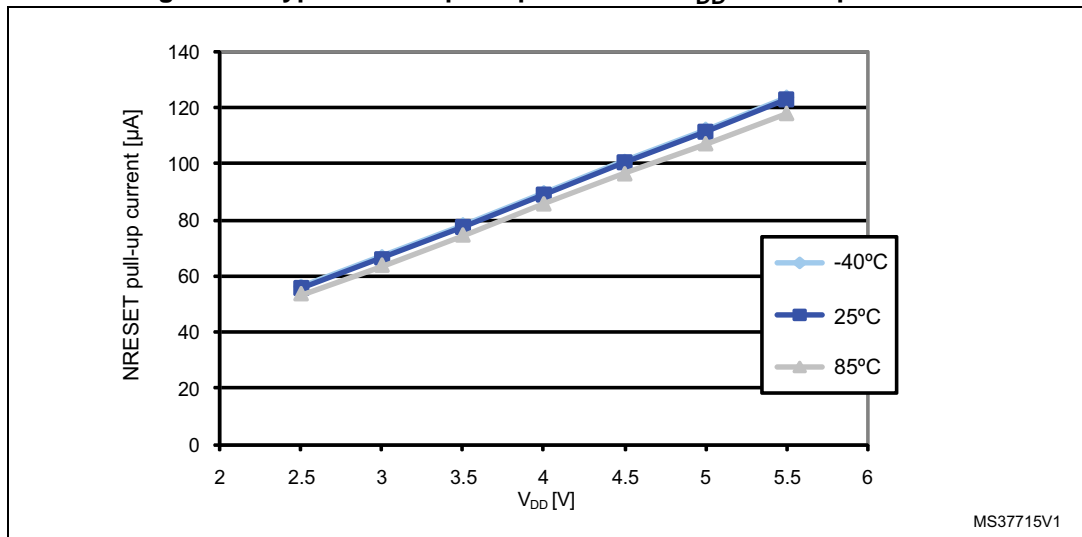
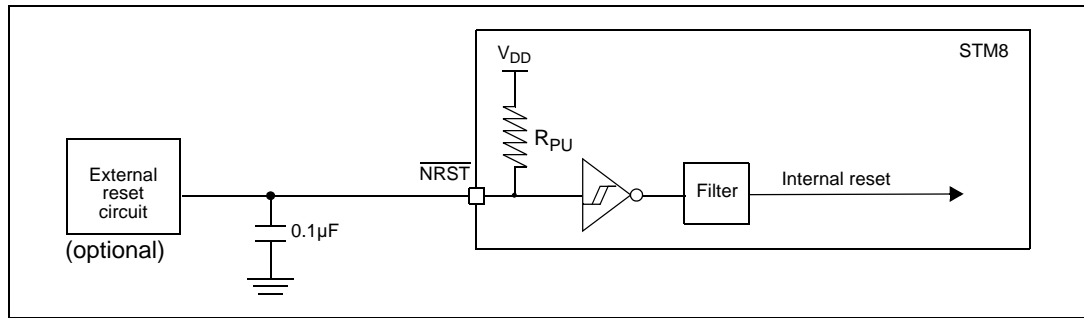

Figure 36. Typical NRST pull-up current vs V_{DD} @ 3 temperatures



The reset network shown in [Figure 37](#) protects the device against parasitic resets. The user must ensure that the level on the NRST pin can go below the V_{IL} max. level specified in [Table 36](#). Otherwise the reset is not taken into account internally. For power consumption sensitive applications, the capacity of the external reset capacitor can be reduced to limit charge/discharge current. If the NRST signal is used to reset the external circuitry, care must be taken of the charge/discharge time of the external capacitor to fulfill the external device’s reset timing conditions. The minimum recommended capacity is 10 nF.

Figure 37. Recommended reset pin protection



9.3.8 SPI serial peripheral interface

Unless otherwise specified, the parameters given in [Table 41](#) are derived from tests performed under ambient temperature, f_{MASTER} frequency and V_{DD} supply voltage conditions. $t_{MASTER} = 1/f_{MASTER}$.

Refer to I/O port characteristics for more details on the input/output alternate function characteristics (NSS, SCK, MOSI, MISO).

Table 41. SPI characteristics

Symbol	Parameter	Conditions	Min	Max	Unit
f_{SCK} $1/t_c(SCK)$	SPI clock frequency	Master mode	0	8	MHz
		Slave mode	0	6	
$t_r(SCK)$ $t_f(SCK)$	SPI clock rise and fall time	Capacitive load: C = 30 pF	-	25	ns
$t_{su(NSS)}^{(1)}$	NSS setup time	Slave mode	$4 \times t_{MASTER}$	-	
$t_h(NSS)^{(1)}$	NSS hold time	Slave mode	70	-	
$t_w(SCKH)^{(1)}$ $t_w(SCKL)^{(1)}$	SCK high and low time	Master mode	$t_{SCK}/2 - 15$	$t_{SCK}/2 + 15$	
$t_{su(MI)}^{(1)}$ $t_{su(SI)}^{(1)}$	Data input setup time	Master mode	5	-	
		Slave mode	5	-	
$t_h(MI)^{(1)}$ $t_h(SI)^{(1)}$	Data input hold time	Master mode	7	-	
		Slave mode	10	-	
$t_a(SO)^{(1)(2)}$	Data output access time	Slave mode	-	$3 \times t_{MASTER}$	
$t_{dis(SO)}^{(1)(3)}$	Data output disable time	Slave mode	25	-	
$t_v(SO)^{(1)}$	Data output valid time	Slave mode (after enable edge)	-	73	
$t_v(MO)^{(1)}$	Data output valid time	Master mode (after enable edge)	-	36	
$t_h(SO)^{(1)}$ $t_h(MO)^{(1)}$	Data output hold time	Slave mode (after enable edge)	28	-	
		Master mode (after enable edge)	12	-	

1. Values based on design simulation and/or characterization results, and not tested in production.
2. Min time is for the minimum time to drive the output and the max time is for the maximum time to validate the data.
3. Min time is for the minimum time to invalidate the output and the max time is for the maximum time to put the data in Hi-Z.

Figure 38. SPI timing diagram - slave mode and CPHA = 0

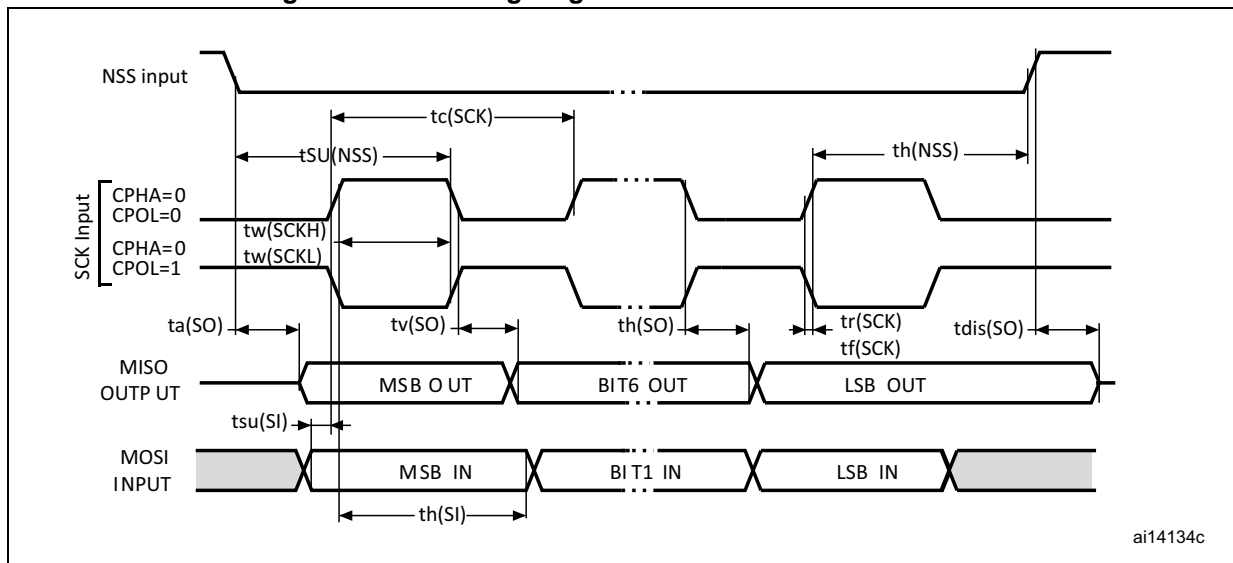
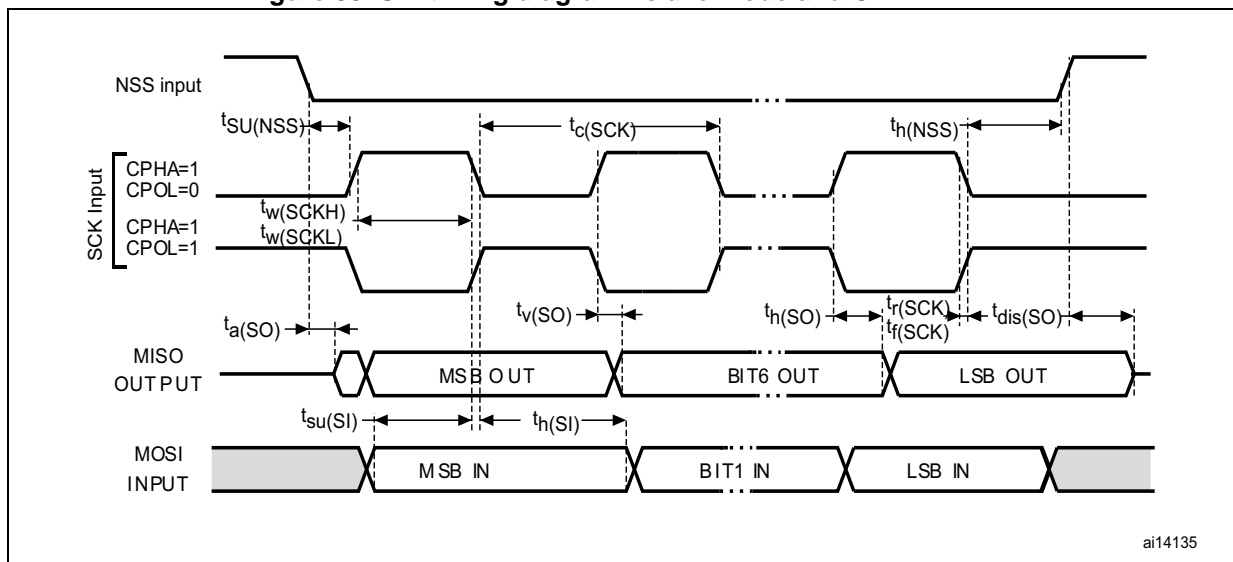
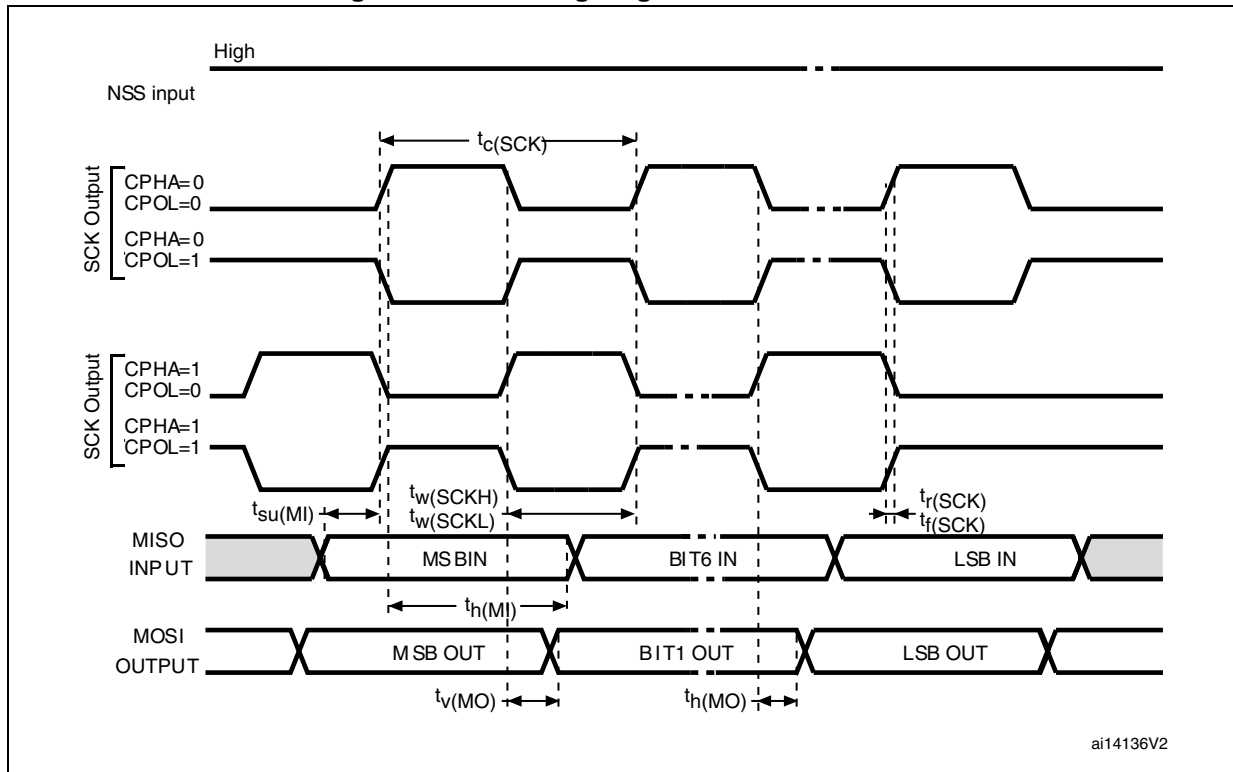

Figure 39. SPI timing diagram - slave mode and CPHA = 1⁽¹⁾



1. Measurement points are done at CMOS levels: 0.3 V_{DD} and 0.7 V_{DD} .

Figure 40. SPI timing diagram - master mode⁽¹⁾



1. Measurement points are done at CMOS levels: 0.3 V_{DD} and 0.7 V_{DD}.

9.3.9 I²C interface characteristicsTable 42. I²C characteristics

Symbol	Parameter	Standard mode I ² C		Fast mode I ² C ⁽¹⁾		Unit
		Min ⁽²⁾	Max ⁽²⁾	Min ⁽²⁾	Max ⁽²⁾	
t _{w(SCLL)}	SCL clock low time	4.7	-	1.3	-	μs
t _{w(SCLH)}	SCL clock high time	4.0	-	0.6	-	
t _{su(SDA)}	SDA setup time	250	-	100	-	ns
t _{h(SDA)}	SDA data hold time	0 ⁽³⁾	-	0 ⁽⁴⁾	900 ⁽³⁾	
t _{r(SDA)} t _{r(SCL)}	SDA and SCL rise time	-	1000	-	300	
t _{f(SDA)} t _{f(SCL)}	SDA and SCL fall time	-	300	-	300	
t _{h(STA)}	START condition hold time	4.0	-	0.6	-	μs
t _{su(STA)}	Repeated START condition setup time	4.7	-	0.6	-	
t _{su(STO)}	STOP condition setup time	4.0	-	0.6	-	μs
t _{w(STO:STA)}	STOP to START condition time (bus free)	4.7	-	1.3	-	μs
C _b	Capacitive load for each bus line	-	400	-	400	pF

1. f_{MASTER}, must be at least 8 MHz to achieve max fast I²C speed (400kHz)
2. Data based on standard I²C protocol requirement, not tested in production
3. The maximum hold time of the start condition has only to be met if the interface does not stretch the low time
4. The device must internally provide a hold time of at least 300 ns for the SDA signal in order to bridge the undefined region of the falling edge of SCL

Figure 41. Typical application with I²C bus and timing diagram

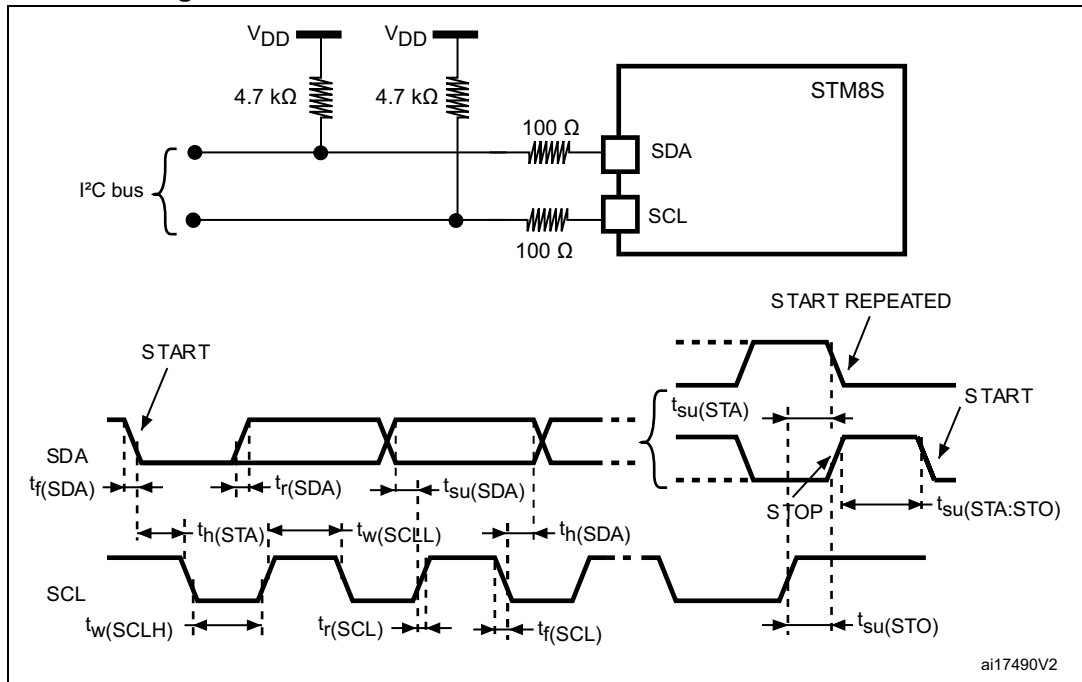

1. Measurement points are made at CMOS levels: 0.3 x V_{DD} and 0.7 x V_{DD}

9.3.10 10-bit ADC characteristics

Subject to general operating conditions for V_{DDA} , f_{MASTER} , and T_A unless otherwise specified.

Table 43. ADC characteristics

Symbol	Parameter	Conditions	Min	Typ	Max	Unit
f_{ADC}	ADC clock frequency	$V_{DDA} = 3 \text{ to } 5.5 \text{ V}$	1	-	4	MHz
		$V_{DDA} = 4.5 \text{ to } 5.5 \text{ V}$	1	-	6	
V_{DDA}	Analog supply	-	3	-	5.5	V
V_{REF+}	Positive reference voltage	-	2.75 ⁽¹⁾	-	V_{DDA}	V
V_{REF-}	Negative reference voltage	-	V_{SSA}	-	0.5 ⁽¹⁾	V
V_{AIN}	Conversion voltage range ⁽²⁾	-	V_{SSA}	-	V_{DDA}	V
		Devices with external V_{REF+}/V_{REF-} pins	V_{REF-}	-	V_{REF+}	V
C_{ADC}	Internal sample and hold capacitor	-	-	3	-	pF
$t_S^{(2)}$	Sampling time	$f_{ADC} = 4 \text{ MHz}$	0.75			μs
		$f_{ADC} = 6 \text{ MHz}$	0.5			
t_{STAB}	Wakeup time from standby	-	-	7	-	μs
t_{CONV}	Total conversion time (including sampling time, 10-bit resolution)	$f_{ADC} = 4 \text{ MHz}$	3.5			μs
		$f_{ADC} = 6 \text{ MHz}$	2.33			μs
		-	14			$1/f_{ADC}$

1. Data guaranteed by design, not tested in production..
2. During the sample time the input capacitance C_{AIN} (3 pF max) can be charged/discharged by the external source. The internal resistance of the analog source must allow the capacitance to reach its final voltage level within t_S . After the end of the sample time t_S , changes of the analog input voltage have no effect on the conversion result. Values for the sample clock t_S depend on programming.

Table 44. ADC accuracy with $R_{AIN} < 10\text{ k}\Omega$, $V_{DDA} = 5\text{ V}$

Symbol	Parameter	Conditions	Typ	Max ⁽¹⁾	Unit
E _T	Total unadjusted error ⁽²⁾	f _{ADC} = 2 MHz	1.0	2.5	LSB
		f _{ADC} = 4 MHz	1.4	3	
		f _{ADC} = 6 MHz	1.6	3.5	
E _O	Offset error ⁽²⁾	f _{ADC} = 2 MHz	0.6	2.0	
		f _{ADC} = 4 MHz	1.1	2.5	
		f _{ADC} = 6 MHz	1.2	2.5	
E _G	Gain error ⁽²⁾	f _{ADC} = 2 MHz	0.2	2	
		f _{ADC} = 4 MHz	0.6	2.5	
		f _{ADC} = 6 MHz	0.8	2.5	
E _D	Differential linearity error ⁽²⁾	f _{ADC} = 2 MHz	0.7	1.5	
		f _{ADC} = 4 MHz	0.7	1.5	
		f _{ADC} = 6 MHz	0.8	1.5	
E _L	Integral linearity error ⁽²⁾	f _{ADC} = 2 MHz	0.6	1.5	
		f _{ADC} = 4 MHz	0.6	1.5	
		f _{ADC} = 6 MHz	0.6	1.5	

1. Data based on characterization results, not tested in production.
2. ADC accuracy vs. negative injection current: Injecting negative current on any of the analog input pins should be avoided as this significantly reduces the accuracy of the conversion being performed on another analog input. It is recommended to add a Schottky diode (pin to ground) to standard analog pins which may potentially inject negative current. Any positive injection current within the limits specified for I_{INJ(PIN)} and ΣI_{INJ(PIN)} in [Section 9.3.6](#) does not affect the ADC accuracy.

Table 45. ADC accuracy with $R_{AIN} < 10\text{ k}\Omega$, $R_{AIN}, V_{DDA} = 3.3\text{ V}$

Symbol	Parameter	Conditions	Typ	Max ⁽¹⁾	Unit
E _T	Total unadjusted error ⁽²⁾	f _{ADC} = 2 MHz	1.1	2.0	LSB
		f _{ADC} = 4 MHz	1.6	2.5	
E _O	Offset error ⁽²⁾	f _{ADC} = 2 MHz	0.7	1.5	
		f _{ADC} = 4 MHz	1.3	2.0	
E _G	Gain error ⁽²⁾	f _{ADC} = 2 MHz	0.2	1.5	
		f _{ADC} = 4 MHz	0.5	2.0	
E _D	Differential linearity error ⁽²⁾	f _{ADC} = 2 MHz	0.7	1.0	
		f _{ADC} = 4 MHz	0.7	1.0	
E _L	Integral linearity error ⁽²⁾	f _{ADC} = 2 MHz	0.6	1.5	
		f _{ADC} = 4 MHz	0.6	1.5	

1. Data based on characterization results, not tested in production.
2. ADC accuracy vs. negative injection current: Injecting negative current on any of the analog input pins should be avoided as this significantly reduces the accuracy of the conversion being performed on another analog input. It is recommended to add a Schottky diode (pin to ground) to standard analog pins which may potentially inject negative current. Any positive injection current within the limits specified for I_{INJ(PIN)} and ΣI_{INJ(PIN)} in [Section 9.3.6](#) does not affect the ADC accuracy.

Figure 42. ADC accuracy characteristics

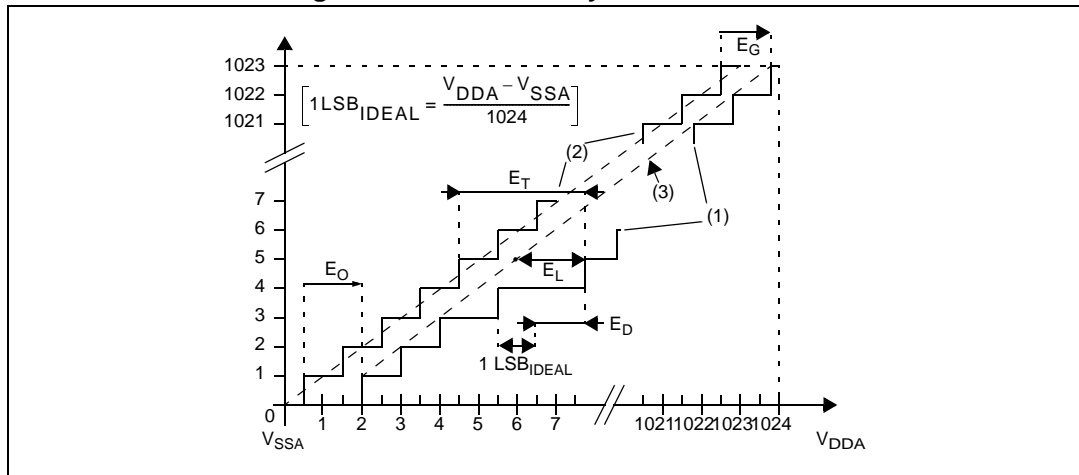

1. Example of an actual transfer curve.
 2. The ideal transfer curve
 3. End point correlation line
- E_T** = Total unadjusted error: maximum deviation between the actual and the ideal transfer curves.
E_O = Offset error: deviation between the first actual transition and the first ideal one.
E_G = Gain error: deviation between the last ideal transition and the last actual one.
E_D = Differential linearity error: maximum deviation between actual steps and the ideal one.
E_L = Integral linearity error: maximum deviation between any actual transition and the end point correlation line.

Figure 43. Typical application with ADC

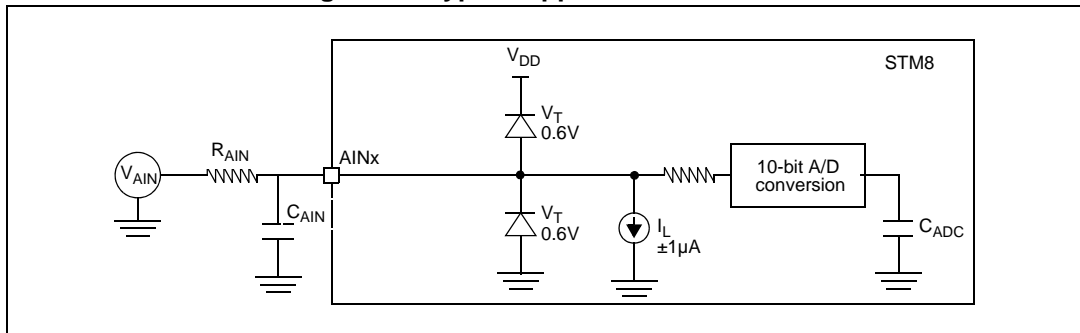

9.3.11 EMC characteristics

Susceptibility tests are performed on a sample basis during product characterization.

Functional EMS (electromagnetic susceptibility)

While executing a simple application (toggling 2 LEDs through I/O ports), the product is stressed by two electromagnetic events until a failure occurs (indicated by the LEDs).

- **ESD:** Electrostatic discharge (positive and negative) is applied on all pins of the device until a functional disturbance occurs. This test conforms with the IEC 61000-4-2 standard.
- **FTB:** A burst of fast transient voltage (positive and negative) is applied to V_{DD} and V_{SS} through a 100 pF capacitor, until a functional disturbance occurs. This test conforms with the IEC 61000-4-4 standard.

A device reset allows normal operations to be resumed. The test results are given in the table below based on the EMS levels and classes defined in application note AN1709.

Designing hardened software to avoid noise problems

EMC characterization and optimization are performed at component level with a typical application environment and simplified MCU software. It should be noted that good EMC performance is highly dependent on the user application and the software in particular.

Therefore it is recommended that the user applies EMC software optimization and prequalification tests in relation with the EMC level requested for his application.

Software recommendations

The software flowchart must include the management of runaway conditions such as:

- Corrupted program counter
- Unexpected reset
- Critical data corruption (control registers...)

Prequalification trials

Most of the common failures (unexpected reset and program counter corruption) can be recovered by applying a low state on the NRST pin or the oscillator pins for 1 second.

To complete these trials, ESD stress can be applied directly on the device, over the range of specification values. When unexpected behavior is detected, the software can be hardened to prevent unrecoverable errors occurring (see application note AN1015).

Table 46. EMS data

Symbol	Parameter	Conditions	Level/class
V_{FESD}	Voltage limits to be applied on any I/O pin to induce a functional disturbance	$V_{DD} = 5\text{ V}$, $T_A = 25\text{ °C}$, $f_{MASTER} = 16\text{ MHz}$, conforming to IEC 61000-4-2	2B ⁽¹⁾
V_{EFTB}	Fast transient voltage burst limits to be applied through 100pF on V_{DD} and V_{SS} pins to induce a functional disturbance	$V_{DD} = 5\text{ V}$, $T_A = 25\text{ °C}$, $f_{MASTER} = 16\text{ MHz}$, conforming to IEC 61000-4-4	4A ⁽¹⁾

1. Data obtained with HSI clock configuration, after applying HW recommendations described in AN2860 - EMC guidelines for STM8Smicrocontrollers.

Electromagnetic interference (EMI)

Emission tests conform to the SAE IEC 61967-2 standard for test software, board layout and pin loading.

Table 47. EMI data

Symbol	Parameter	Conditions				Unit
		General conditions	Monitored frequency band	Max $f_{HSE}/f_{CPU}^{(1)}$		
				8 MHz/8 MHz	8 MHz/16 MHz	
S_{EMI}	Peak level	$V_{DD} = 5 V$ $T_A = 25 ^\circ C$ LQFP48 package conforming to SAE IEC 61967-2	0.1 MHz to 30 MHz	13	14	dB μ V
			30 MHz to 130 MHz	23	19	
			130 MHz to 1 GHz	-4.0	-4.0	
	SAE EMI level	-	2.0	1.5		

1. Data based on characterization results, not tested in production.

Absolute maximum ratings (electrical sensitivity)

Based on two different tests (ESD and LU) using specific measurement methods, the product is stressed in order to determine its performance in terms of electrical sensitivity. For more details, refer to the application note AN1181.

Electrostatic discharge (ESD)

Electrostatic discharges (3 positive then 3 negative pulses separated by 1 second) are applied to the pins of each sample according to each pin combination. The sample size depends on the number of supply pins in the device (3 parts*(n+1) supply pin). This test conforms to the JESD22-A114A/A115A standard. For more details, refer to the application note AN1181.

Table 48. ESD absolute maximum ratings

Symbol	Ratings	Conditions	Class	Maximum value ⁽¹⁾	Unit
$V_{ESD(HBM)}$	Electrostatic discharge voltage (Human body model)	$T_A = 25^\circ C$, conforming to JESD22-A114	A	2000	V
$V_{ESD(CDM)}$	Electrostatic discharge voltage (Charge device model)	$T_A = 25^\circ C$, conforming to JESD22-C101	IV	1000	V

1. Data based on characterization results, not tested in production.

Static latch-up

Two complementary static tests are required on 10 parts to assess the latch-up performance:

- A supply overvoltage (applied to each power supply pin)
- A current injection (applied to each input, output and configurable I/O pin) is performed on each sample.

This test conforms to the EIA/JESD 78 IC latch-up standard. For more details, refer to the application note AN1181.

Table 49. Electrical sensitivities

Symbol	Parameter	Conditions	Class ⁽¹⁾
LU	Static latch-up class	T _A = 25 °C	A
		T _A = 85 °C	A

1. Class description: A Class is an STMicroelectronics internal specification. All its limits are higher than the JEDEC specifications, that means when a device belongs to class A it exceeds the JEDEC standard. B class strictly covers all the JEDEC criteria (international standard).

10 Package information

To meet environmental requirements, ST offers these devices in different grades of ECOPACK® packages, depending on their level of environmental compliance. ECOPACK® specifications, grade definitions and product status are available at www.st.com. ECOPACK® is an ST trademark.

10.1 LQFP48 package information

Figure 44. LQFP48 - 48-pin, 7 x 7 mm low-profile quad flat package outline

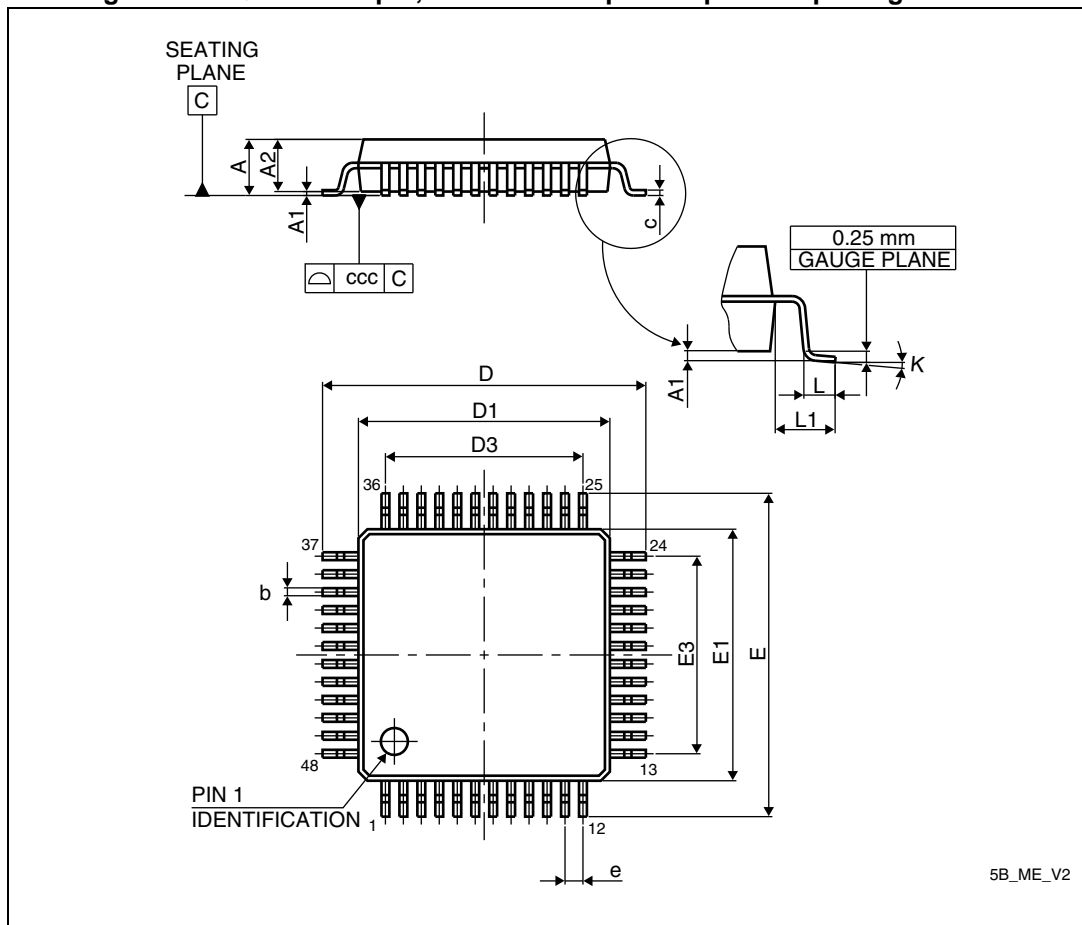

1. Drawing is not to scale.

Table 50. LQFP48 - 48-pin, 7 x 7 mm low-profile quad flat package mechanical data

Symbol	millimeters			inches ⁽¹⁾		
	Min	Typ	Max	Min	Typ	Max
A	-	-	1.600	-	-	0.0630
A1	0.050	-	0.150	0.0020	-	0.0059
A2	1.350	1.400	1.450	0.0531	0.0551	0.0571
b	0.170	0.220	0.270	0.0067	0.0087	0.0106
c	0.090	-	0.200	0.0035	-	0.0079
D	8.800	9.000	9.200	0.3465	0.3543	0.3622
D1	6.800	7.000	7.200	0.2677	0.2756	0.2835
D3	-	5.500	-	-	0.2165	-
E	8.800	9.000	9.200	0.3465	0.3543	0.3622
E1	6.800	7.000	7.200	0.2677	0.2756	0.2835
E3	-	5.500	-	-	0.2165	-
e	-	0.500	-	-	0.0197	-
L	0.450	0.600	0.750	0.0177	0.0236	0.0295
L1	-	1.000	-	-	0.0394	-
k	0°	3.5°	7°	0°	3.5°	7°
ccc	-	-	0.080	-	-	0.0031

1. Values in inches are converted from mm and rounded to 4 decimal digits.

Figure 45. LQFP48 - 48-pin, 7 x 7 mm low-profile quad flat recommended footprint

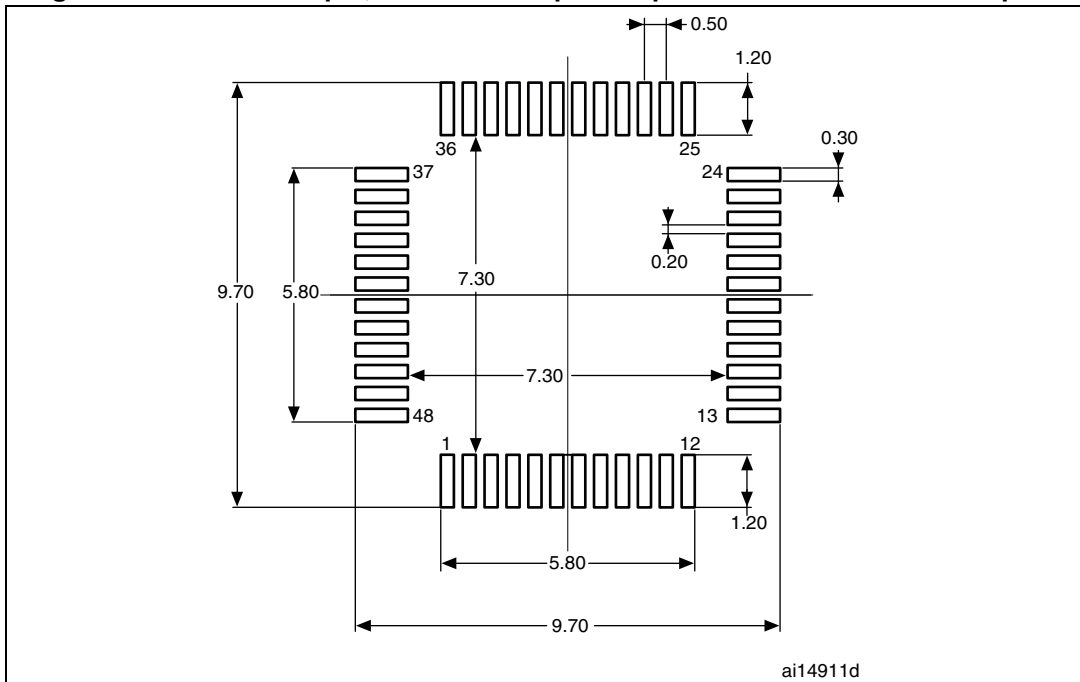

1. Dimensions are expressed in millimeters.

Device marking

The following figure gives an example of topside marking orientation versus pin 1 identifier location.

Figure 46. LQFP48 marking example (package top view)

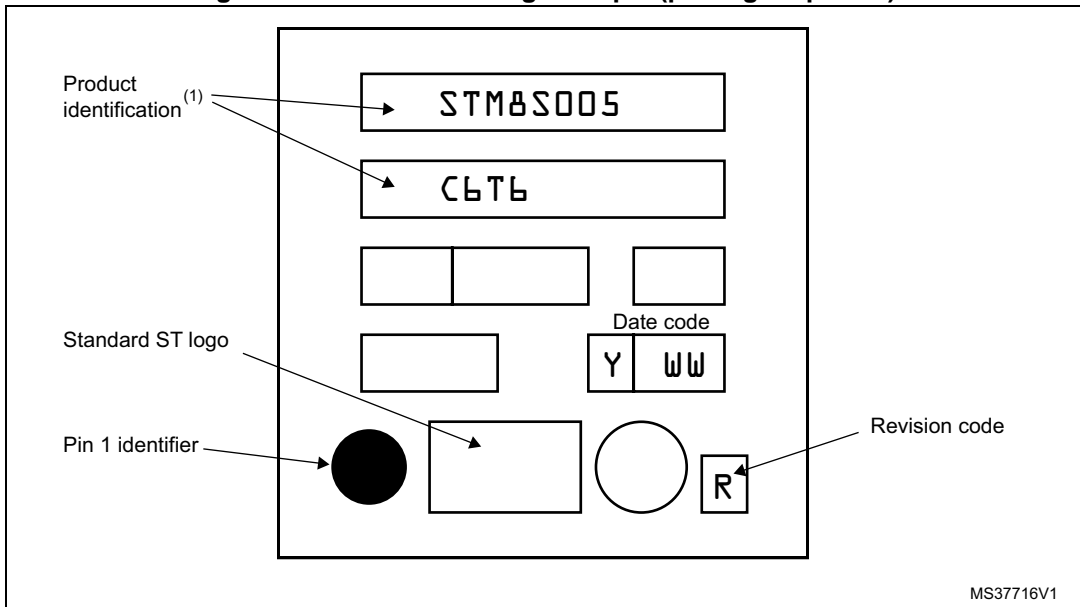

1. Parts marked as "ES", "E" or accompanied by an Engineering Sample notification letter, are not yet qualified and therefore not yet ready to be used in production and any consequences deriving from such usage will not be at ST charge. In no event, ST will be liable for any customer usage of these engineering samples in production. ST Quality has to be contacted prior to any decision to use these Engineering Samples to run qualification activity.

10.2 LQFP32 package information

Figure 47. LQFP32 - 32-pin, 7 x 7 mm low-profile quad flat package outline

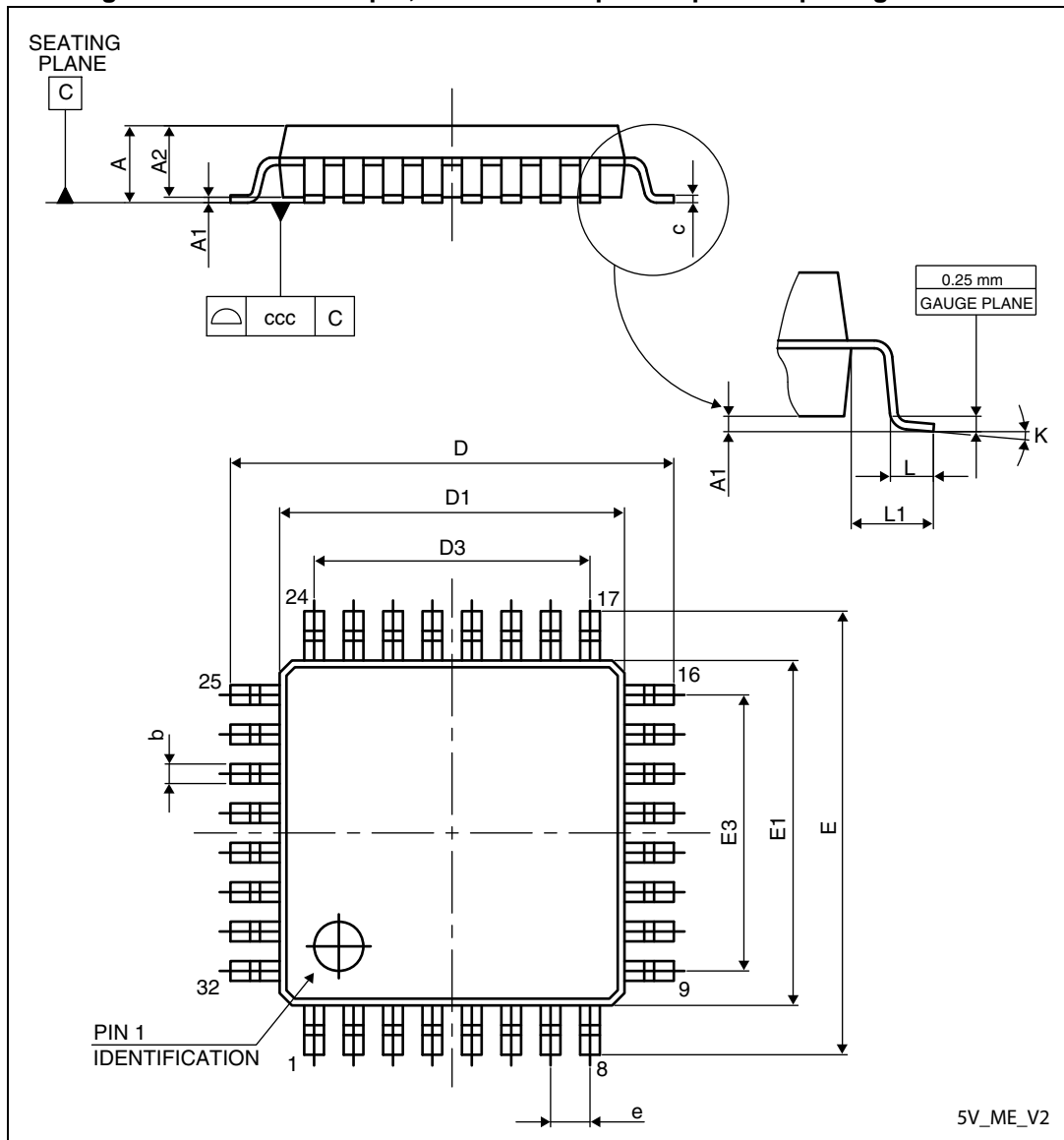

1. Drawing is not to scale.

5V_ME_V2

Table 51. LQFP32 - 32-pin, 7 x 7 mm low-profile quad flat package mechanical data

Symbol	millimeters			inches ⁽¹⁾		
	Min	Typ	Max	Min	Typ	Max
A	-	-	1.600	-	-	0.0630
A1	0.050	-	0.150	0.0020	-	0.0059
A2	1.350	1.400	1.450	0.0531	0.0551	0.0571
b	0.300	0.370	0.450	0.0118	0.0146	0.0177
c	0.090	-	0.200	0.0035	-	0.0079
D	8.800	9.000	9.200	0.3465	0.3543	0.3622
D1	6.800	7.000	7.200	0.2677	0.2756	0.2835
D3	-	5.600	-	-	0.2205	-
E	8.800	9.000	9.200	0.3465	0.3543	0.3622
E1	6.800	7.000	7.200	0.2677	0.2756	0.2835
E3	-	5.600	-	-	0.2205	-
e	-	0.800	-	-	0.0315	-
L	0.450	0.600	0.750	0.0177	0.0236	0.0295
L1	-	1.000	-	-	0.0394	-
k	0°	3.5°	7°	0°	3.5°	7°
ccc	-	-	0.100	-	-	0.0039

1. Values in inches are converted from mm and rounded to 4 decimal digits.

Figure 48. LQFP32 - 32-pin, 7 x 7 mm low-profile quad flat recommended footprint

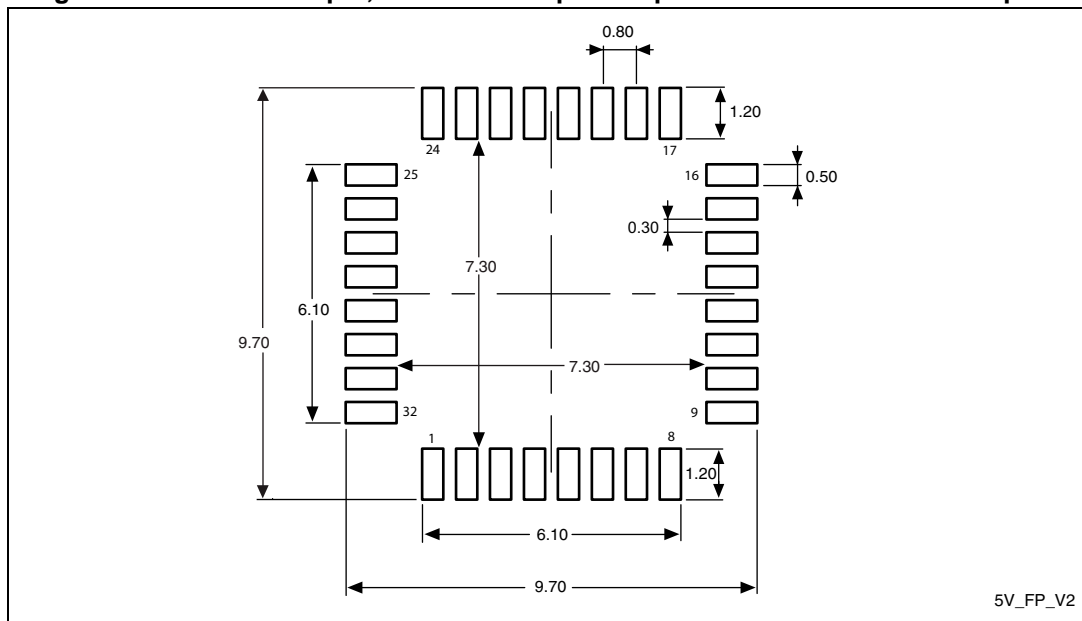

1. Dimensions are expressed in millimeters.

Device marking

The following figure gives an example of topside marking orientation versus pin 1 identifier location.

Figure 49. LQFP32 marking example (package top view)

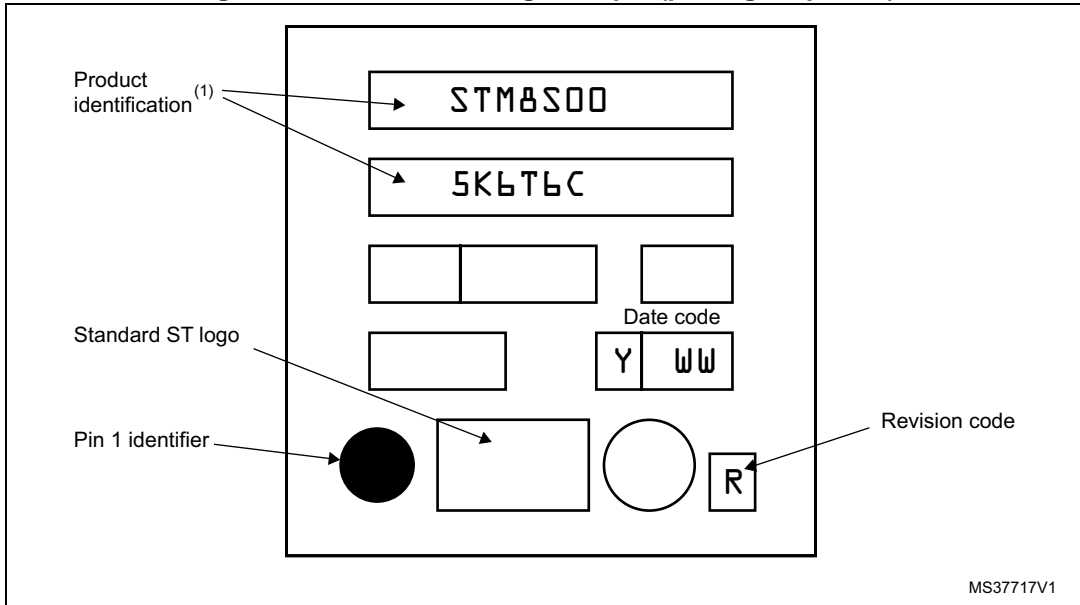

1. Parts marked as "ES", "E" or accompanied by an Engineering Sample notification letter, are not yet qualified and therefore not yet ready to be used in production and any consequences deriving from such usage will not be at ST charge. In no event, ST will be liable for any customer usage of these engineering samples in production. ST Quality has to be contacted prior to any decision to use these Engineering Samples to run qualification activity.

10.3 Thermal characteristics

The maximum chip junction temperature (T_{Jmax}) must never exceed the values given in [Table 17: General operating conditions](#).

The maximum chip-junction temperature, T_{Jmax} , in degrees Celsius, may be calculated using the following equation:

$$T_{Jmax} = T_{Amax} + (P_{Dmax} \times \Theta_{JA})$$

Where:

- T_{Amax} is the maximum ambient temperature in °C
- Θ_{JA} is the package junction-to-ambient thermal resistance in °C/W
- P_{Dmax} is the sum of P_{INTmax} and $P_{I/Omax}$ ($P_{Dmax} = P_{INTmax} + P_{I/Omax}$)
- P_{INTmax} is the product of I_{DD} and V_{DD} , expressed in Watts. This is the maximum chip internal power.
- $P_{I/Omax}$ represents the maximum power dissipation on output pins, where:
 $P_{I/Omax} = \Sigma (V_{OL} * I_{OL}) + \Sigma ((V_{DD} - V_{OH}) * I_{OH})$, and taking account of the actual V_{OL}/I_{OL} and V_{OH}/I_{OH} of the I/Os at low and high level in the application.

Table 52. Thermal characteristics⁽¹⁾

Symbol	Parameter	Value	Unit
Θ_{JA}	Thermal resistance junction-ambient LQFP 48 - 7 x 7 mm	57	°C/W
	Thermal resistance junction-ambient LQFP 32 - 7 x 7 mm	60	°C/W

1. Thermal resistances are based on JEDEC JESD51-2 with 4-layer PCB in a natural convection environment.

10.3.1 Reference document

JESD51-2 integrated circuits thermal test method environment conditions - natural convection (still air). Available from www.jedec.org.

10.3.2 Selecting the product temperature range

When ordering the microcontroller, the temperature range is specified in the order code (see [Figure 50: STM8S005C6/K6 value line ordering information scheme\(1\)](#)).

The following example shows how to calculate the temperature range needed for a given application.

Assuming the following application conditions:

- Maximum ambient temperature $T_{Amax} = 82\text{ °C}$ (measured according to JESD51-2)
- $I_{DDmax} = 15\text{ mA}$, $V_{DD} = 5.5\text{ V}$
- Maximum eight standard I/Os used at the same time in output at low level with $I_{OL} = 10\text{ mA}$, $V_{OL} = 2\text{ V}$
- Maximum four high sink I/Os used at the same time in output at low level with $I_{OL} = 20\text{ mA}$, $V_{OL} = 1.5\text{ V}$
- Maximum two true open drain I/Os used at the same time in output at low level with $I_{OL} = 20\text{ mA}$, $V_{OL} = 2\text{ V}$

$$P_{INTmax} = 15\text{ mA} \times 5.5\text{ V} = 82.5\text{ mW}$$

$$P_{IOmax} = (10\text{ mA} \times 2\text{ V} \times 8) + (20\text{ mA} \times 2\text{ V} \times 2) + (20\text{ mA} \times 1.5\text{ V} \times 4) = 360\text{ mW}$$

This gives: $P_{INTmax} = 82.5\text{ mW}$ and $P_{IOmax} = 360\text{ mW}$:

$$P_{Dmax} = 82.5\text{ mW} + 360\text{ mW}$$

$$\text{Thus: } P_{Dmax} = 443\text{ mW}$$

Using the values obtained in [Table 52: Thermal characteristics on page 91](#) T_{Jmax} is calculated as follows for LQFP64 10 x 10 mm = 46 °C/W:

$$T_{Jmax} = 82\text{ °C} + (46\text{ °C/W} \times 443\text{ mW}) = 82\text{ °C} + 20\text{ °C} = 102\text{ °C}$$

This is within the range of the suffix 6 version parts ($-40 < T_J < 105\text{ °C}$).

In this case, parts must be ordered at least with the temperature range suffix 6.

11 Part numbering

Figure 50. STM8S005C6/K6 value line ordering information scheme⁽¹⁾

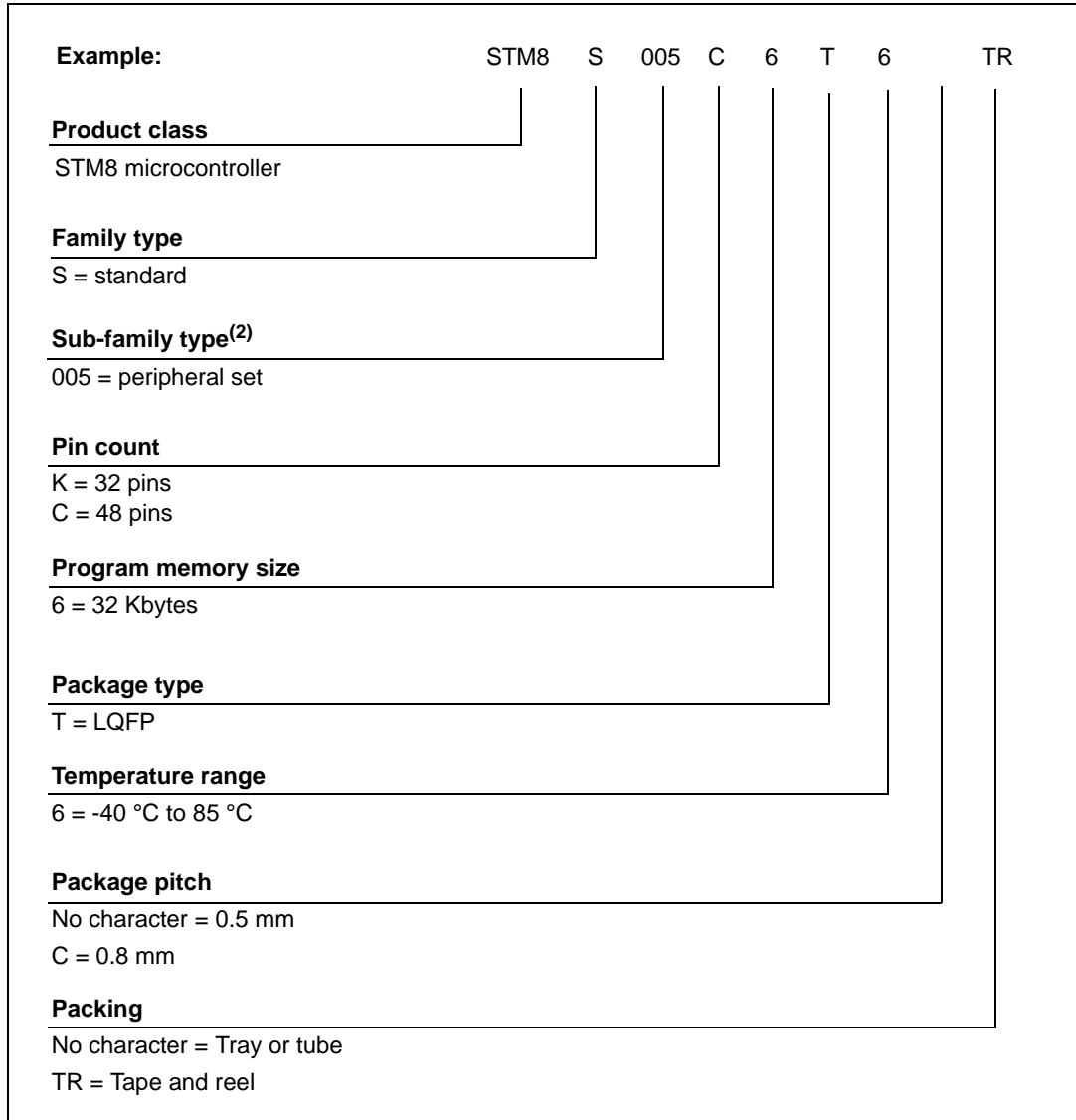

1. For a list of available options (e.g. memory size, package) and orderable part numbers or for further information on any aspect of this device, please go to www.st.com or contact the ST Sales Office nearest to you.
2. Refer to [Table 1: STM8S005C6/K6 value line features](#) for detailed description.

12 STM8 development tools

Development tools for the STM8 microcontrollers include the full-featured STice emulation system supported by a complete software tool package including C compiler, assembler and integrated development environment with high-level language debugger. In addition, the STM8 is to be supported by a complete range of tools including starter kits, evaluation boards and a low-cost in-circuit debugger/programmer.

12.1 Emulation and in-circuit debugging tools

The STice emulation system offers a complete range of emulation and in-circuit debugging features on a platform that is designed for versatility and cost-effectiveness. In addition, STM8 application development is supported by a low-cost in-circuit debugger/programmer.

The STice is the fourth generation of full featured emulators from STMicroelectronics. It offers new advanced debugging capabilities including profiling and coverage to help detect and eliminate bottlenecks in application execution and dead code when fine tuning an application.

In addition, STice offers in-circuit debugging and programming of STM8 microcontrollers via the STM8 single wire interface module (SWIM), which allows non-intrusive debugging of an application while it runs on the target microcontroller.

For improved cost effectiveness, STice is based on a modular design that allows users to order exactly what they need to meet their development requirements and to adapt their emulation system to support existing and future ST microcontrollers.

STice key features

- Occurrence and time profiling and code coverage (new features)
- Advanced breakpoints with up to 4 levels of conditions
- Data breakpoints
- Program and data trace recording up to 128 KB records
- Read/write on the fly of memory during emulation
- In-circuit debugging/programming via SWIM protocol
- 8-bit probe analyzer
- 1 input and 2 output triggers
- Power supply follower managing application voltages between 1.62 to 5.5 V
- Modularity that allows users to specify the components users need to meet their development requirements and adapt to future requirements
- Supported by free software tools that include integrated development environment (IDE), programming software interface and assembler for STM8.

12.2 Software tools

STM8 development tools are supported by a complete, free software package from STMicroelectronics that includes ST Visual Develop (STVD) IDE and the ST Visual Programmer (STVP) software interface. STVD provides seamless integration of the Cosmic and Raisonance C compilers for STM8. A free version that outputs up to 32 Kbytes of code is available.

12.2.1 STM8 toolset

STM8 toolset with STVD integrated development environment and STVP programming software is available for free download at www.st.com. This package includes:

ST Visual Develop – Full-featured integrated development environment from ST, featuring

- Seamless integration of C and ASM toolsets
- Full-featured debugger
- Project management
- Syntax highlighting editor
- Integrated programming interface
- Support of advanced emulation features for STIce such as code profiling and coverage

ST Visual Programmer (STVP) – Easy-to-use, unlimited graphical interface allowing read, write and verify the user STM8 microcontroller Flash program memory, data EEPROM and option bytes. STVP also offers project mode for saving programming configurations and automating programming sequences.

12.2.2 C and assembly toolchains

Control of C and assembly toolchains is seamlessly integrated into the STVD integrated development environment, making it possible to configure and control the building of user application directly from an easy-to-use graphical interface.

Available toolchains include:

- **Cosmic C compiler for STM8** – One free version that outputs up to 32 Kbytes of code is available. For more information, see www.cosmic-software.com.
- **Raisonance C compiler for STM8** – One free version that outputs up to 32 Kbytes of code. For more information, see www.raisonance.com.
- **STM8 assembler linker** – Free assembly toolchain included in the STVD toolset, which allows users to assemble and link the user application source code.

12.3 Programming tools

During the development cycle, STIce provides in-circuit programming of the STM8 Flash microcontroller on user application board via the SWIM protocol. Additional tools are to include a low-cost in-circuit programmer as well as ST socket boards, which provide dedicated programming platforms with sockets for programming the user STM8.

For production environments, programmers will include a complete range of gang and automated programming solutions from third-party tool developers already supplying programmers for the STM8 family.

13 Revision history

Table 53. Document revision history

Date	Revision	Changes
14-Oct-2011	1	Initial release.
09-Jan-2012	2	Updated: <ul style="list-style-type: none"> – t_{RET} in Table 35: Flash program memory/data EEPROM memory, – R_{PU} in Table 40: NRST pin characteristics and Table 36: I/O static characteristics, – the notes related to V_{CAP} in Section 9.3: Operating conditions.
13-Jun-2012	3	Updated the temperature condition for factory calibrated ACC_{HSI} in Table 32: HSI oscillator characteristics . Changed SCK input to SCK output in Figure 40: SPI timing diagram - master mode(1) .
26-Mar-2015	4	Updated: <ul style="list-style-type: none"> – the buffer size in Section 4.13: Analog-to-digital converter (ADC1), – the disclaimer. Added: <ul style="list-style-type: none"> – the note to Power-on reset threshold in Table 18: Operating conditions at power-up/power-down, – Figure 46: LQFP48 marking example (package top view), – Figure 49: LQFP32 marking example (package top view).

IMPORTANT NOTICE – PLEASE READ CAREFULLY

STMicroelectronics NV and its subsidiaries ("ST") reserve the right to make changes, corrections, enhancements, modifications, and improvements to ST products and/or to this document at any time without notice. Purchasers should obtain the latest relevant information on ST products before placing orders. ST products are sold pursuant to ST's terms and conditions of sale in place at the time of order acknowledgement.

Purchasers are solely responsible for the choice, selection, and use of ST products and ST assumes no liability for application assistance or the design of Purchasers' products.

No license, express or implied, to any intellectual property right is granted by ST herein.

Resale of ST products with provisions different from the information set forth herein shall void any warranty granted by ST for such product.

ST and the ST logo are trademarks of ST. All other product or service names are the property of their respective owners.

Information in this document supersedes and replaces information previously supplied in any prior versions of this document.

© 2015 STMicroelectronics – All rights reserved

